

## 16-bit constant current LED sink driver

### ■ General Description

LN0134 is designed for LED displays. As an enhancement of its predecessor, LN0134 exploits Precision Drive™ technology to enhance its output characteristics. LN0134 contains a serial buffer and data latches which convert serial input data into parallel output format. At LN0134 output stage, sixteen regulated current ports are designed to provide uniform and constant current sinks for driving LEDs within a large range of Vf variations. LN0134 provides users with great flexibility and device performance while using LN0134 in their system design for LED display applications, e.g. LED panels. Users may adjust the output current from 3 mA to 45 mA through an external resistor, Rext, which gives users flexibility in controlling the light intensity of LEDs. LN0134 guarantees to endure maximum 17V at the output port. The high clock frequency, 25 MHz, also satisfies the system requirements of high volume data transmission.

### ■ Applications

- White LED Backlighting
- LCD Display Supply
- Horse race lamp

### ■ Ordering Information

Model	Package
LN0134DR	P-DIP24-300-2.54
LN0134SR	SOP24-300-1.27
LN0134PR	SSOP24 (0.635-D1.40)
LN0134FR	SSOP24 (1.0-D1.50)

### ■ Features

- 16 constant-current output channels
- Constant output current invariant to load voltage change
- Excellent output current accuracy:
- Between channels: <math>\lt; \pm 3\% \text{ (max.)}</math>, and between ICs: <math>\lt; \pm 6\% \text{ (max.)}</math>
- Output current adjusted through an external resistor
- Constant output current range: 3-45 mA
- 25MHz clock frequency
- Schmitt trigger input
- Supply voltage 3.3V/5V

### ■ Package

- LN0134SR:SOP24
- LN0134DR:DIP24
- LN0134PR:SSOP24 (0.635-D1.4)
- LN0134FR:SSOP24 (1.0-D1.50)

## Pin Configuration

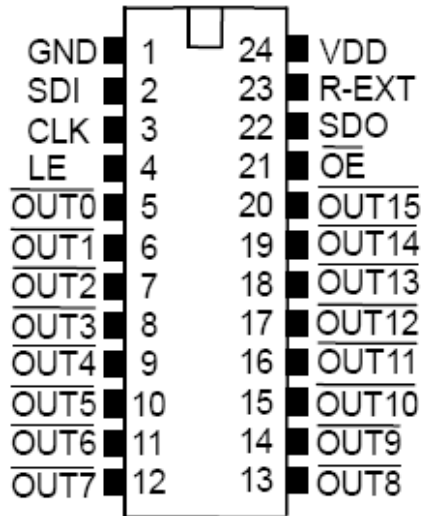

Pin Number	Pin Name	Pin Function
1	GND	Power Ground
2	SDI	Serial data input
3	CLK	Serial clock input
4	LE	Data latch enable (Active HIGH)
5~20	OUT0 ~ OUT15	Constant output
21	OE	Current output enable (Active LOW)
22	SDO	Serial data output
23	R-EXT	External resistor connection terminal
24	VDD	5V Power Input

## Block Diagram

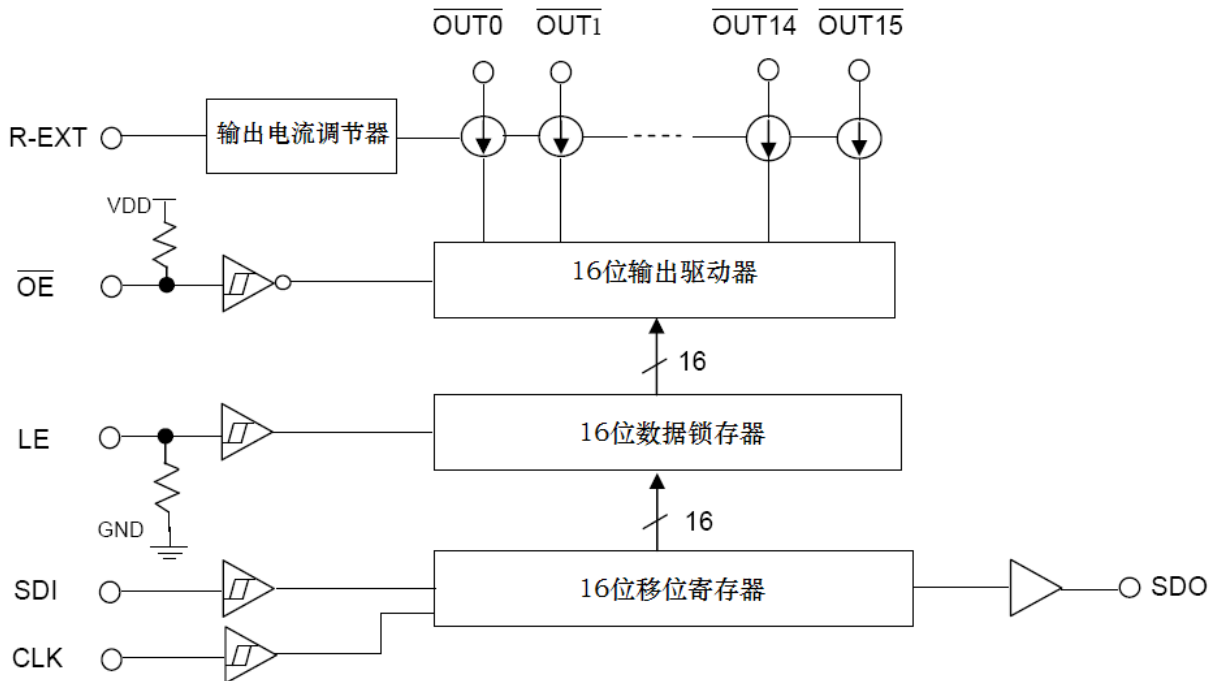

## Absolute Maximum Ratings

( $T_A=25^\circ\text{C}$ )

Parameter	Symbol	Absolute maximum ratings	Units	
Power supply voltage	$V_{DD}$	GND-0.3~7	V	
Input voltage	$V_{IN}$	-0.3~ $V_{DD}+0.3$	V	
Output voltage	$V_{OUT}$	-0.5~20	V	
Output current	$I_{OUT}$	70	mA	
GND current	$I_{GND}$	1.0	A	
Data clock frequency	Fclk	25	MHz	
Operating temperature range	Topr	-40~85	$^\circ\text{C}$	
Storage temperature range	Tstg	-65~150	$^\circ\text{C}$	
Lead temperature(Soldering,10 sec)	Tref	260	$^\circ\text{C}$	
Power Dissipation (On PCB board)	$P_D$	DIP24	2.3	W
		SOP24	2.1	
		SSOP24(0.635-D1.4)	1.4	
		SSOP24(1.0-D1.5)	1.9	
Package Thermal Resistance $R_{th(j-a)}$ (On PCB board)	$P_D$	DIP24	53.8	$^\circ\text{C/W}$
		SOP24	49.8	
		SSOP24(0.635-D1.4)	88.5	
		SSOP24(1.0-D1.5)	66.7	

**Caution:** The absolute maximum ratings are rated values exceeding which the product could suffer physical damage. These values must therefore not be exceeded under any conditions.

## Equivalent Circuits of Inputs and Outputs

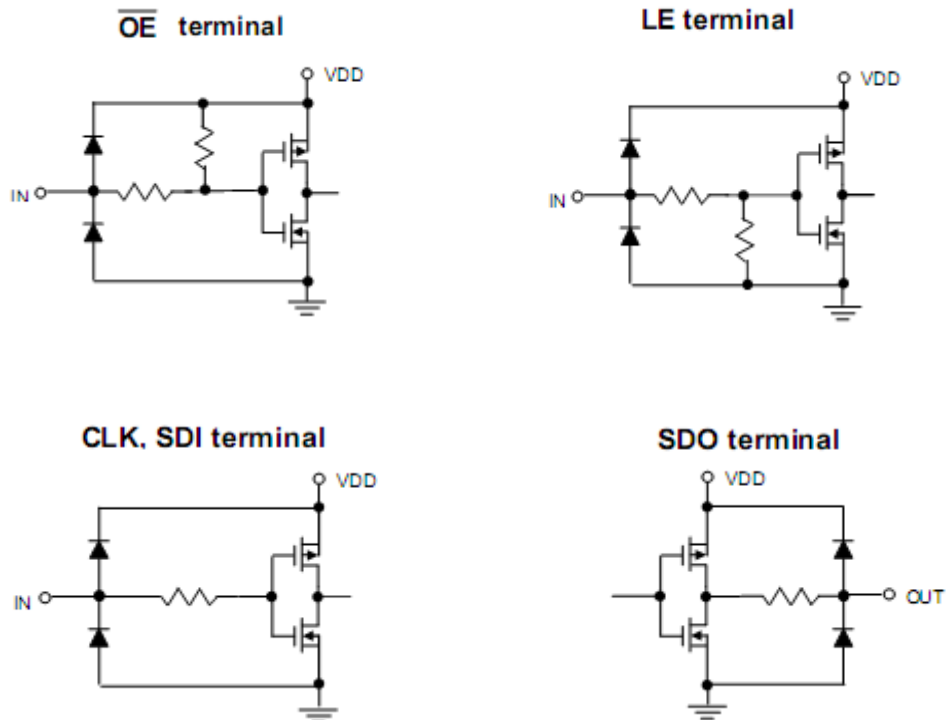

**Electrical Characteristics**

VDD=5V

(Ta=25°C, except specify)

Parameter	Symbol	Test Condition	Min.	Typ.	Max.	Units
Power supply Voltage	V <sub>DD</sub>		4.5	5	5.5	V
Supply current	I <sub>DD</sub> (off) 1	Rext not connect, $\overline{\text{OUT0}} \sim \overline{\text{OUT15}} = \text{off}$	-	3.6	5.5	mA
	I <sub>DD</sub> (off) 2	Rext=1.24K, $\overline{\text{OUT0}} \sim \overline{\text{OUT15}} = \text{off}$	-	4	6.5	mA
	I <sub>DD</sub> (off) 3	Rext=620, $\overline{\text{OUT0}} \sim \overline{\text{OUT15}} = \text{off}$	-	6	9.0	mA
	I <sub>DD</sub> (on) 1	Rext=1.24K	-	4.5	7	mA
	I <sub>DD</sub> (on) 2	Rext=620	-	6.5	9.5	mA
Undervoltage Lockout threshold	V <sub>UVLO</sub>		-	2.5	-	V
Output Voltage	V <sub>DS</sub>	$\overline{\text{OUT0}} \sim \overline{\text{OUT15}}$	0.4	-	17.0	V
Output Current	I <sub>OUT</sub>	$\overline{\text{OUT0}} \sim \overline{\text{OUT15}}$	3	-	45	mA
	I <sub>SDO</sub>	SDO	-0.9	-	0.9	mA
Input Voltage	V <sub>IH</sub>		0.8V <sub>DD</sub>	-	V <sub>DD</sub>	V
	V <sub>IL</sub>		GND	-	0.3V <sub>DD</sub>	
Output Current	I <sub>out</sub>	V <sub>ds</sub> =1.0V, Rext=1240Ω	-	15	-	mA
		V <sub>ds</sub> =1.0V, Rext=620Ω	-	30	-	mA
Current matching	I <sub>OUT-OUT-ERR</sub>	10mA < I <sub>out</sub> < 40mA, V <sub>ds</sub> =1.0V	-	±1	±3	%
Current accuracy	I <sub>ERR</sub>	3mA < I <sub>out</sub> < 45mA, V <sub>ds</sub> =1.0V	-	±3	±6	%
Current Linearity	I <sub>LINEAR-VDS</sub>	1.0V < V <sub>DS</sub> < 3V	-	±0.1	±0.5	%
	I <sub>LINEAR-VDD</sub>	4.5V < V <sub>DD</sub> < 5.5V	-	±1	±2.5	%
PULL-Up resistance	R <sub>IN-UP</sub>	OE	300K	600K	1200K	Ω
PULL-Down resistance	R <sub>IN-DOWN</sub>	LE	300K	600K	1200K	Ω
Input clock frequency	F <sub>CLK</sub>	When IC concatenation	-	-	25M	Hz
Minimum Pulse Width	t <sub>w-CLK-LE</sub>	CLK, LE	20	-	-	nS
	t <sub>w-OE</sub>	OE	200	-	-	nS
SDI setup time	t <sub>su</sub>		5			nS
SDI hold time	t <sub>h</sub>		10			nS
Delay time	t <sub>PLH</sub> , t <sub>PHL</sub>		-	100	200	nS
CLK edge time	t <sub>r</sub> , t <sub>f</sub>	Climb time and fall time	-	-	500	nS

**VDD=3.3V**

(Ta=25°C, except specify)

Parameter	Symbol	Test Condition	Min.	Typ.	Max.	Units
Power supply Voltage	V <sub>DD</sub>		3.0	3.3	3.5	V
Supply current	I <sub>DD</sub> (off) 1	R <sub>ext</sub> not connect, $\overline{\text{OUT0}} \sim \overline{\text{OUT15}} = \text{off}$	-	1.5	4	mA
	I <sub>DD</sub> (off) 2	R <sub>ext</sub> =1.86K, $\overline{\text{OUT0}} \sim \overline{\text{OUT15}} = \text{off}$	-	3.5	6.5	mA
	I <sub>DD</sub> (off) 3	R <sub>ext</sub> =750, $\overline{\text{OUT0}} \sim \overline{\text{OUT15}} = \text{off}$	-	5.5	8.5	mA
	I <sub>DD</sub> (on) 1	R <sub>ext</sub> =1.86K	-	3.5	6	mA
	I <sub>DD</sub> (on) 2	R <sub>ext</sub> =750	-	5.5	8.5	mA
Undervoltage Lockout Threshold	V <sub>UVLO</sub>		-	2.5	-	V
Output Voltage	V <sub>DS</sub>	$\overline{\text{OUT0}} \sim \overline{\text{OUT15}}$	0.4	-	17.0	V
Output Current	I <sub>OUT</sub>	$\overline{\text{OUT0}} \sim \overline{\text{OUT15}}$	3	-	30	mA
	I <sub>SDO</sub>	SDO	-0.9	-	0.9	mA
Input Voltage	V <sub>IH</sub>		0.8VDD	-	VDD	V
	V <sub>IL</sub>		GND	-	0.3VDD	
Output Current	I <sub>out</sub>	V <sub>ds</sub> =1.0V, R <sub>ext</sub> =1240Ω	-	10	-	mA
		V <sub>ds</sub> =1.0V, R <sub>ext</sub> =620Ω	-	25	-	mA
Current matching	I <sub>OUT-OUT-ERR</sub>	10mA<I <sub>out</sub> <40mA V <sub>ds</sub> =1.0V	-	±1	±3	%
Current accuracy	I <sub>ERR</sub>	3mA<I <sub>out</sub> <45mA, V <sub>ds</sub> =1.0V	-	±3	±6	%
Current Linearity	I <sub>LINEAR-VDS</sub>	1.0V<V <sub>DS</sub> <3V	-	±0.1	±0.5	%
	I <sub>LINEAR-VDD</sub>	4.5V<V <sub>DD</sub> <5.5V	-	±1	±2.5	%
PULL-Up resistance	R <sub>IN-UP</sub>	OE	300K	600K	1200K	Ω
PULL-Down resistance	R <sub>IN-DOWN</sub>	LE	300K	600K	1200K	Ω
Input clock frequency	F <sub>CLK</sub>	When IC concatenation	-	-	25M	Hz
Minimum Pulse Width	t <sub>W-CLK-LE</sub>	CLK、LE	40	-	-	nS
	t <sub>W-OE</sub>	OE	300	-	-	nS
SDI setup time	t <sub>su</sub>		10			nS
SDI hold time	t <sub>h</sub>		20			nS
Delay time	t <sub>PLH</sub> , t <sub>PHL</sub>		-	150	300	nS
CLK edge time	t <sub>f</sub> , t <sub>r</sub>	Climb time and fall time	-	-	500	nS



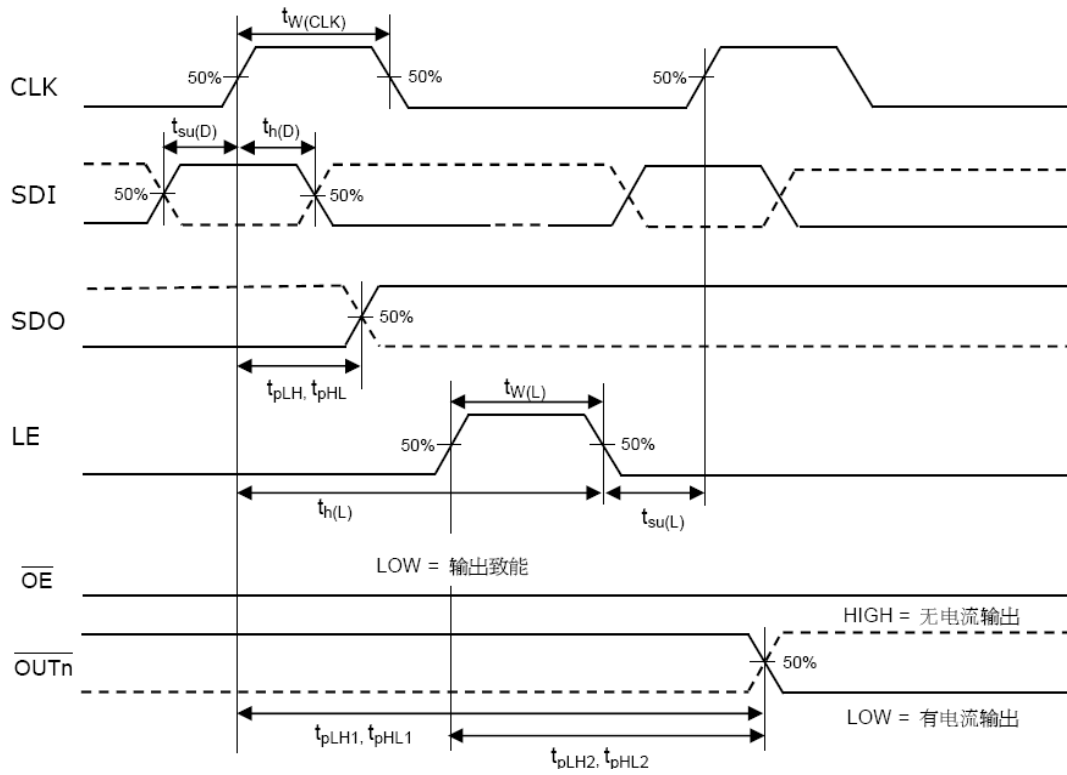

■ Timing Waveforms

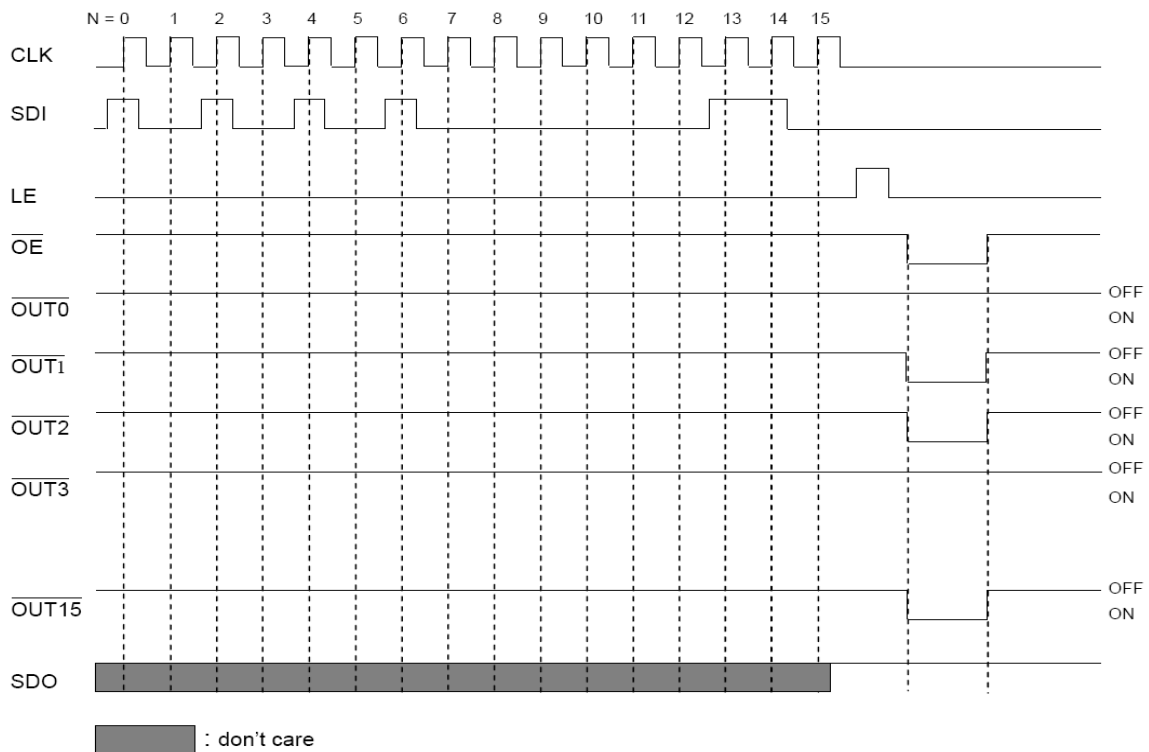

■ Timing Diagram



## Truth Table

CLK	LE	$\overline{OE}$	SDI	$\overline{OUT0} \dots \overline{OUT7} \dots \overline{OUT15}$	SDO
	H	L	$D_n$	$\overline{D_n} \dots \overline{D_{n-7}} \dots \overline{D_{n-15}}$	$D_{n-15}$
	L	L	$D_{n+1}$	不变	$D_{n-14}$
	H	L	$D_{n+2}$	$\overline{D_{n+2}} \dots \overline{D_{n-5}} \dots \overline{D_{n-13}}$	$D_{n-13}$
	X	L	$D_{n+3}$	$\overline{D_{n+2}} \dots \overline{D_{n-5}} \dots \overline{D_{n-13}}$	$D_{n-13}$
	X	H	$D_{n+3}$	使LED不亮	$D_{n-13}$

## Application Information

### Constant Current

In LED display application, LN0134 provides nearly no variations in current from channel to channel and from IC to IC. This can be achieved by:

$$I_{OUT} = \frac{V_{R-EXT}}{R_{EXT}} \times 15, \quad V_{R-EXT} = 1.26V$$

- 1) The maximum current variation between channels is less than  $\pm 3\%$ , and that between ICs is less than  $\pm 6\%$ .
- 2) In addition, the current characteristic of output stage is flat and users can refer to the figure as shown below. The output current can be kept constant regardless of the variations of LED forward voltages ( $V_f$ ). This performs as a perfection of load regulation.

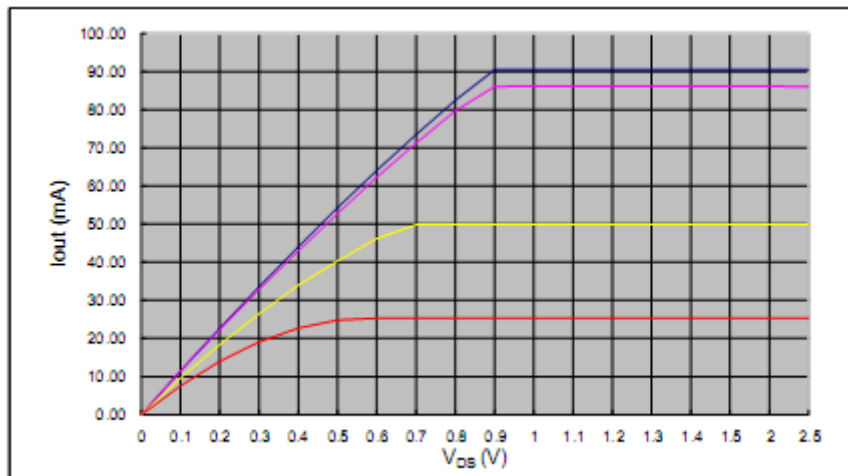

### Adjusting Output Current

The output current of each channel ( $I_{OUT}$ ) is set by an external resistor,  $R_{EXT}$ . The relationship between  $I_{OUT}$  and  $R_{EXT}$  is shown in the following figure.

Also, the output current can be calculated from the equation:  $V_{R-EXT} = 1.26V$ ;  $I_{OUT} = (V_{R-EXT} / R_{EXT}) \times 15$

where  $R_{EXT}$  is the resistance of the external resistor connected to  $R_{EXT}$  terminal and  $V_{R-EXT}$  is the voltage of  $R_{EXT}$  terminal. The magnitude of current (as a function of  $R_{EXT}$ ) is around 150mA at 1260 $\Omega$  and 30mA at 630 $\Omega$ .

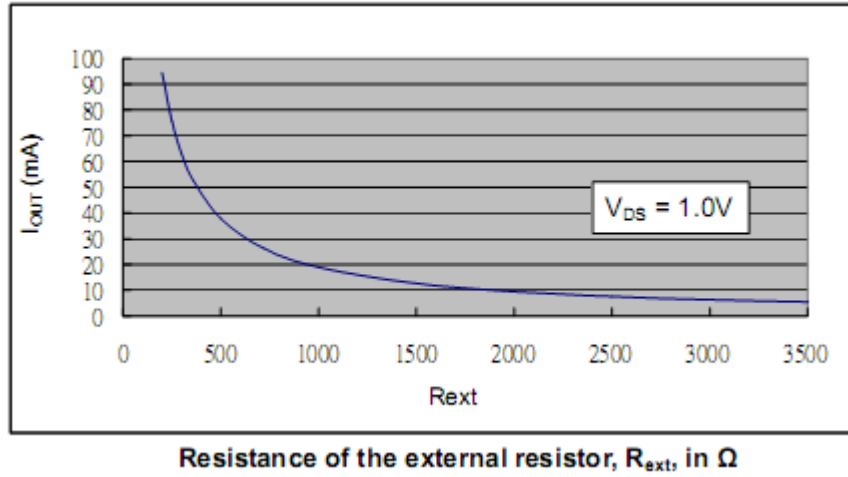

Load Supply Voltage (V<sub>LED</sub>)

LN0134 are designed to operate with V<sub>DS</sub> ranging from 0.4V to 1.0V considering the package power dissipating limits. V<sub>DS</sub> may be higher enough to make P<sub>D(act)</sub> > P<sub>D(max)</sub> when V<sub>LED</sub>= 5V and V<sub>DS</sub> = V<sub>LED</sub> - V<sub>f</sub>, in which V<sub>LED</sub> is the load supply voltage. In this case, it is recommended to use the lowest possible supply voltage or to set an external voltage reducer, V<sub>DROP</sub>. A voltage reducer lets V<sub>DS</sub> = (V<sub>LED</sub> - V<sub>f</sub>) - V<sub>DROP</sub>. Resistors or Zener diode can be used in the applications as shown in the following figures.

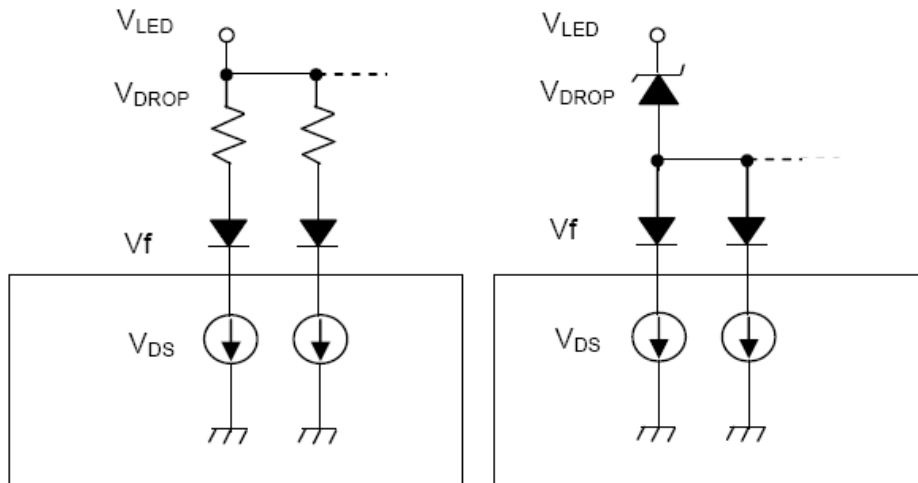



■ Package Information

- DIP24(LN0134DR)

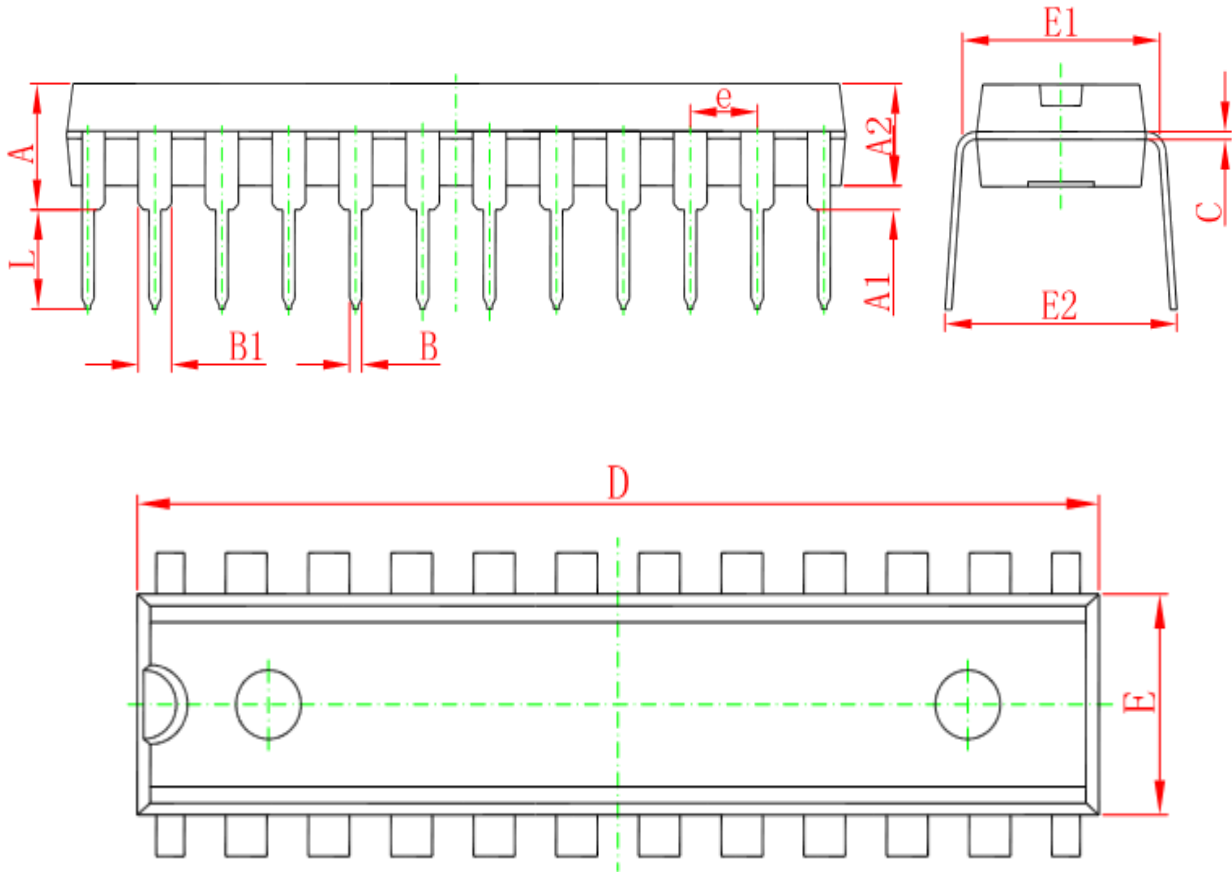

Symbol	Dimensions In Millimeters		Dimensions In Inches	
	Min	Max	Min	Max
A	3.710	4.310	0.146	0.170
A1	0.510		0.020	
A2	3.200	3.600	0.126	0.142
B	0.380	0.570	0.015	0.022
B1	1.270 (BSC)		0.050 (BSC)	
C	0.204	0.360	0.008	0.014
D	29.250	29.850	1.152	1.175
E	6.200	6.600	0.244	0.260
E1	7.320	7.920	0.288	0.312
e	2.540 (BSC)		0.100 (BSC)	
L	3.000	3.600	0.118	0.142
E2	8.400	9.000	0.331	0.354

● SOP24 (LN0134CR)

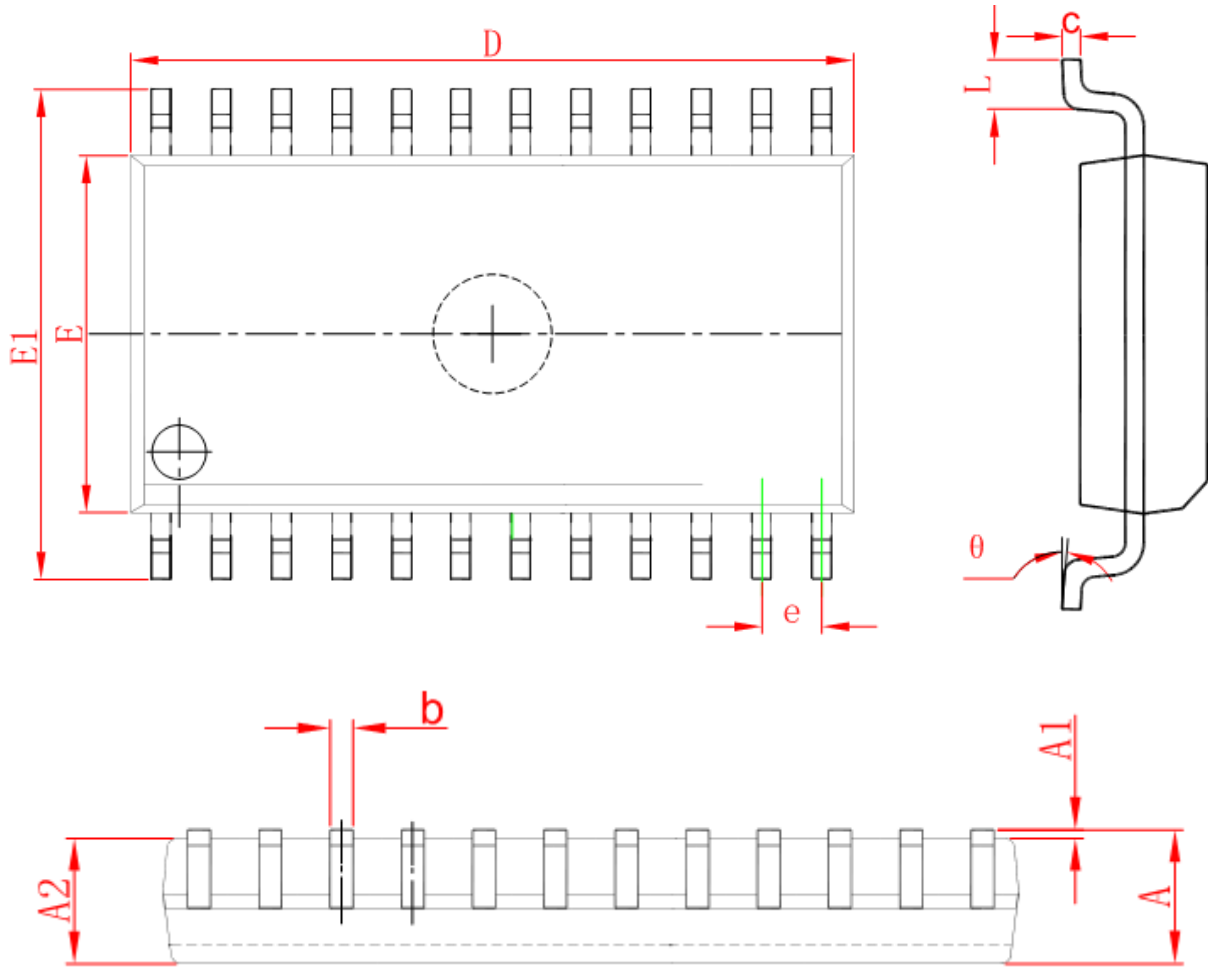

Symbol	Dimensions In Millimeters		Dimensions In Inches	
	Min	Max	Min	Max
A	2.350	2.650	0.093	0.104
A1	0.100	0.300	0.004	0.012
A2	2.100	2.500	0.083	0.098
b	0.330	0.510	0.013	0.020
c	0.204	0.330	0.008	0.013
D	15.200	15.600	0.598	0.614
E	7.400	7.600	0.291	0.299
E1	10.210	10.610	0.402	0.418
e	1.270 (BSC)		0.050 (BSC)	
L	0.400	1.270	0.016	0.050
θ	0°	8°	0°	8°

● SSOP24 (0.635-D1.4) (LN0134PR)

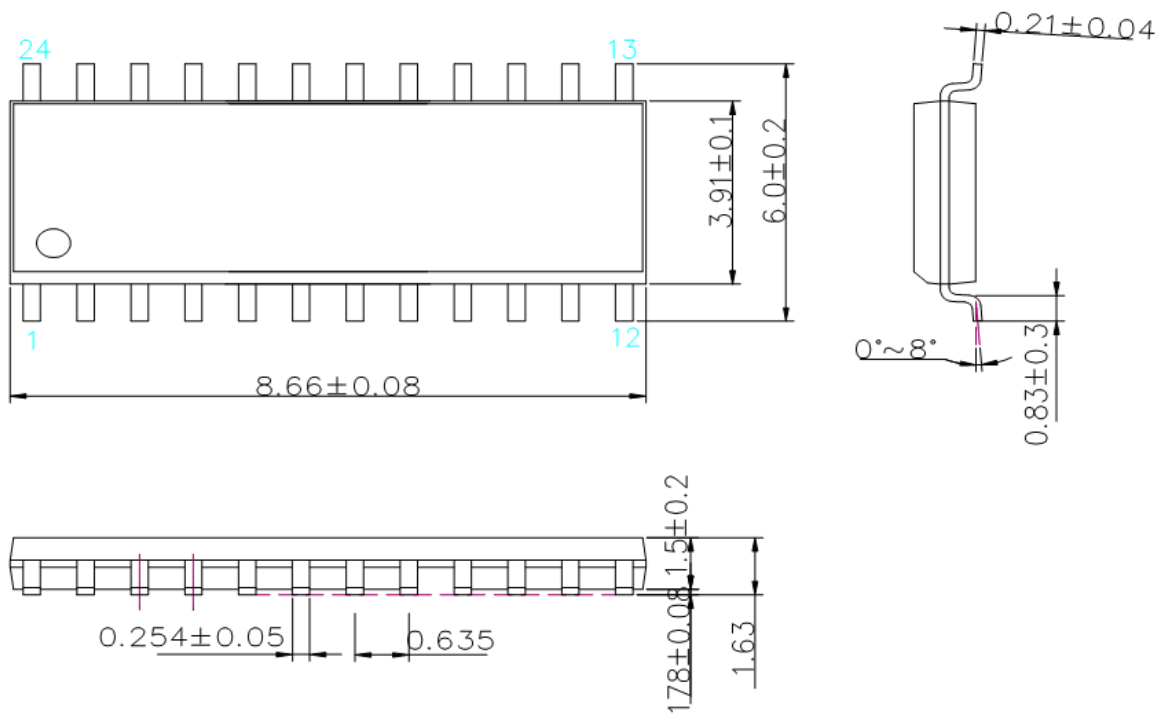

● SSOP24 (1.0-D1.5) (LN0134FR)

