

High Ripple-Rejection Low Dropout CMOS Voltage Regulator

General Description

The LN1130 Series is a positive voltage regulator with a low dropout voltage, high output voltage accuracy, and low current consumption developed based on CMOS technology.

A built-in low on-resistance transistor provides a low dropout voltage and large output current, and a built-in overcurrent protector prevents the load current from exceeding the current capacitance of the output transistor. Small SOT-89-3, SOT23-3 package realize high-density mounting..

Applications

- Power supply for DVD and CD-ROM drives
- Power supply for battery-powered devices
- Power supply for personal communication devices
- Power supply for note PCs

Ordering Information

LN1130P ①②③④⑤

Designator	Symbol	Description	Designator	Symbol	Description
① ②	Integer	Output Voltage: eg: ①=3, ②=0 ⇒ 3.0V	④	P	SOT-89-3L (B Type)
②	2	Accuracy: ±2%		R	SOT-89-3L (A Type)
③		Package Type	⑤		Embossed Tape
	M	SOT-23-3L		R	Standard Feed
	V	SOT-23-3B		L	Reverse Feed

Features

- Output voltage: 1.5 V to 5.5 V, selectable in 0.1 V steps.
- High-accuracy output voltage: ±2.0%
- Low dropout voltage: 250mV typ. (3.0V output product, $I_{OUT} = 100 \text{ mA}$)
- Low current consumption during operation: 60μA (typ.), 80μA (max.)
- During shutdown: 0.1 μA (typ.), 1.0 μA (max.)
- High peak current capability: 300mA output is possible (at $V_{IN} \geq V_{OUT(S)} + 1.0 \text{ V}$)
- Built-in ON/OFF circuit: ensures long battery life.
- High ripple rejection: 55dB typ. (at 1.0 kHz)
- Built-in overcurrent protector: overcurrent of output transistor can be restricted.
- Small package: SOT-89-3, SOT-23-3, other required

Package

- SOT-89-3L
- SOT-23-3L, SOT-23-3B

Pin Configuration

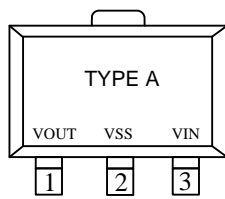

SOT-89-3L
(Top View)

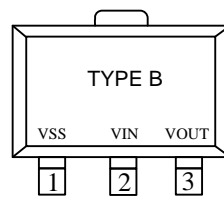

SOT-89-3L
(Top View)

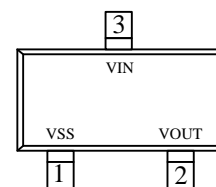

SOT-23-3L/SOT-23-3B
(Top View)

Pin Assignment

Pin Number			Pin Name	Function
SOT-23-3L/B	SOT-89-3(A)	SOT-89-3(B)		
3	3	2	VIN	Power Supply
1	2	1	VSS	Ground
2	1	3	VOUT	Output Pin

Marking Rule

SOT-89-3L and SOT-23-3L/B

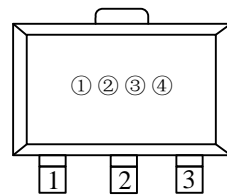

SOT-89-3L
(Top View)

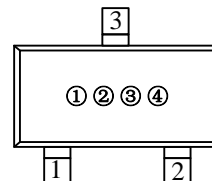

SOT-23-3L/SOT-23-3B
(Top View)

① Represents the product name

Symbol	Product Name
S	LN1130◆◆◆◆◆◆

② Represents the range of output voltage

Output Voltage Range (V)	0.1~3.0	3.1~6.0	6.1~9.0
Symbol	5	6	7

③ Represents the Output Voltage

Symbol	Output Voltage (V)			Symbol	Output Voltage (V)		
0	-	3.1	-	F	1.6	4.6	-
1	-	3.2	-	H	1.7	4.7	-
2	-	3.3	-	K	1.8	4.8	-
3	-	3.4	-	L	1.9	4.9	-
4	-	3.5	-	M	2	5.0	-
5	-	3.6	-	N	2.1	5.1	-
6	-	3.7	-	P	2.2	5.2	-
7	-	3.8	-	R	2.3	5.3	-
8	-	3.9	-	S	2.4	5.4	-
9	-	4	-	T	2.5	5.5	-
A	-	4.1	-	U	2.6	5.6	-
B	1.2	4.2	-	V	2.7	5.7	-
C	1.3	4.3	-	X	2.8	5.8	-
D	1.4	4.4	-	Y	2.9	5.9	-
E	1.5	4.5	-	Z	3	6.0	-

④ Represents the assembly lot no.

0~9, A~Z repeated (G, I, J, O, Q, W excepted)

■ Function Block Diagram

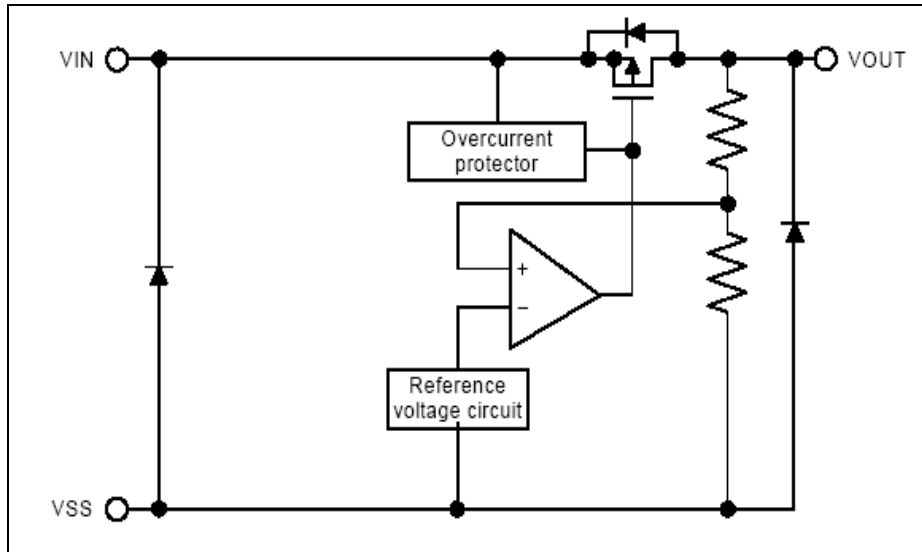

■ Absolute Maximum Ratings

Parameter	Symbol	Maximum Rating		Unit
Input Voltage	V_{IN}	$V_{SS}-0.3 \sim V_{SS}+8$		V
Output Current	V_{OUT}	$V_{SS}-0.3 \sim V_{IN}+0.3$		
Power Dissipation	P_D	SOT-23-3	250	mW
		SOT-89-3	500	
Operating Ambient Temperature	T_{opr}	-40~+85		°C
Storage Temperature	T_{stg}	-40~+125		

Caution: The absolute maximum ratings are rated values exceeding which the product could suffer physical damage. These values must therefore not be exceeded under any conditions.

■ Typical Application Circuit

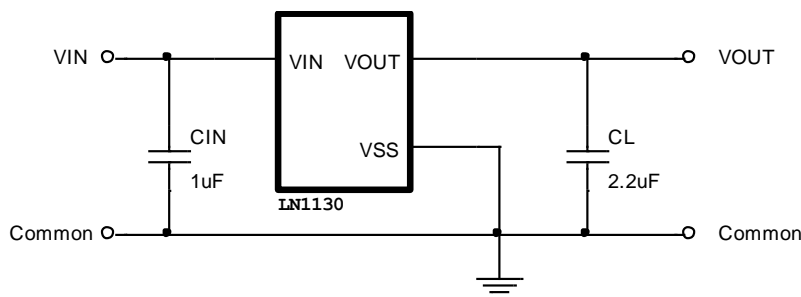

Caution: The above connection diagram and constant will not guarantee successful operation. Perform thorough evaluation using the actual application to set the constant.

Electrical Characteristics

Item	Symbol	Condition	Min	Typ	Max	Unit	Test circuit	
Output voltage	$V_{OUT(E)1}$	$V_{IN} = V_{OUT(S)} + 1.0 \text{ V}, I_{OUT} = 30 \text{ mA}$	$V_{OUT(S)} \times 0.99$	$V_{OUT(S)}$	$V_{OUT(S)} \times 1.01$	V	1	
	$V_{OUT(E)2}$	$V_{IN} = V_{OUT(S)} + 1.0 \text{ V}, I_{OUT} = 80 \text{ mA}$	$V_{OUT(S)} \times 0.98$	$V_{OUT(S)}$	$V_{OUT(S)} \times 1.02$	V		
Output current*2	I_{OUT}	$V_{IN} \geq V_{OUT(S)} + 1.0 \text{ V}$	300	—	—	mA	3	
Dropout voltage	V_{drop}	$I_{OUT} = 100 \text{ mA}$	$2.2 \text{ V} \leq V_{OUT(S)} \leq 2.5 \text{ V}$	—	0.30	0.49	V	1
			$2.6 \text{ V} \leq V_{OUT(S)} \leq 3.3 \text{ V}$	—	0.25	0.34		
			$3.4 \text{ V} \leq V_{OUT(S)} \leq 5.5 \text{ V}$	—	0.20	0.28		
Line regulation	$\frac{\Delta V_{OUT1}}{\Delta V_{IN} \cdot V_{OUT}}$	$V_{OUT(S)} + 0.5 \text{ V} \leq V_{IN} \leq 7 \text{ V}$ $I_{OUT} = 80 \text{ mA}$	—	0.05	0.2	%/V	1	
Load regulation	ΔV_{OUT2}	$V_{IN} = V_{OUT(S)} + 1.0 \text{ V}$ $1.0 \text{ mA} \leq I_{OUT} \leq 80 \text{ mA}$	—	20	40	mV	1	
temperature coefficient	$\frac{\Delta V_{OUT}}{\Delta T_a \cdot V_{OUT}}$	$V_{IN} = V_{OUT(S)} + 1.0 \text{ V}, I_{OUT} = 10 \text{ mA}$ $-40^\circ\text{C} \leq T_a \leq 85^\circ\text{C}$	—	± 100	—	ppm/°C	1	
Current consumption during operation	I_{SS1}	$V_{IN} = V_{OUT(S)} + 1.0 \text{ V},$	—	60	80	μA	2	
Input voltage	V_{IN}	—	2.0	—	7	V	—	
Ripple rejection	RR	$V_{IN} = V_{OUT(S)} + 1.0 \text{ V}, f = 1.0 \text{ kHz}$ $V_{rip} = 0.5 \text{ V}_{rms}, I_{OUT} = 80 \text{ mA}$	—	55	—	dB	4	
Short-circuit current	I_{short}	$V_{IN} = V_{OUT(S)} + 1.0 \text{ V},$ ON/OFF pin ON, $V_{OUT} = 0 \text{ V}$	—	30	—	mA	3	

Test Circuits

Circuit 1

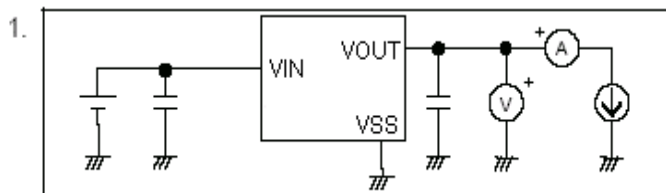

Circuit 2

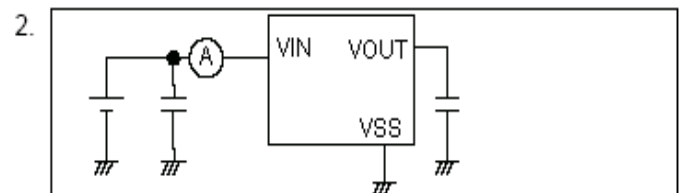

Circuit 3

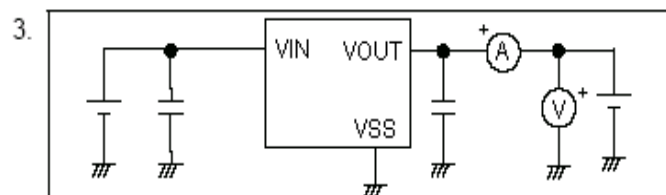

Circuit 4

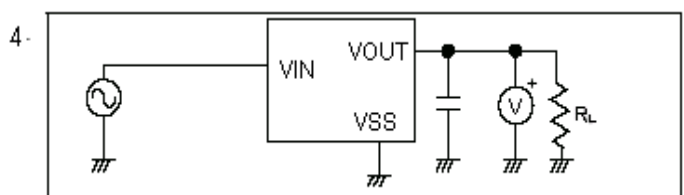

Typical Performance Characteristics

1. Output voltage vs. Output current (when load current increases)

LN1130 (1.5V)

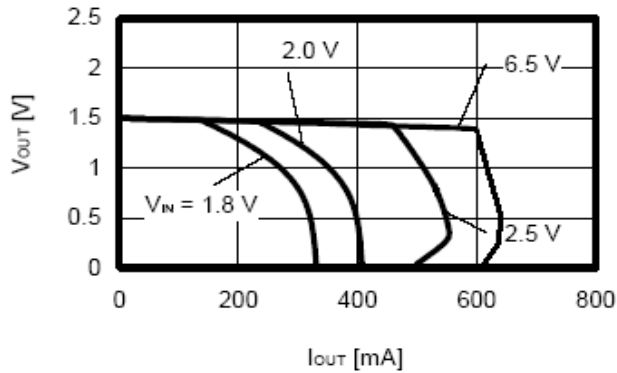

LN1130 (3.0V)

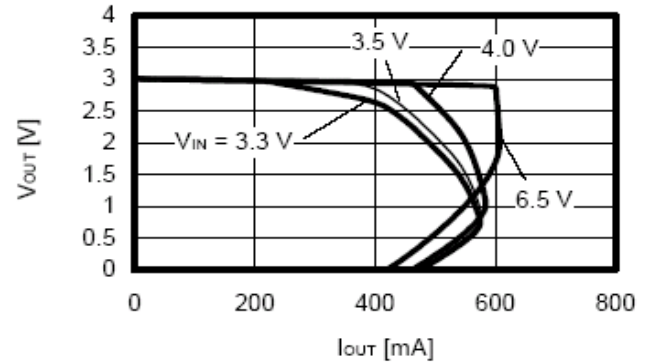

LN1130 (5.0V)

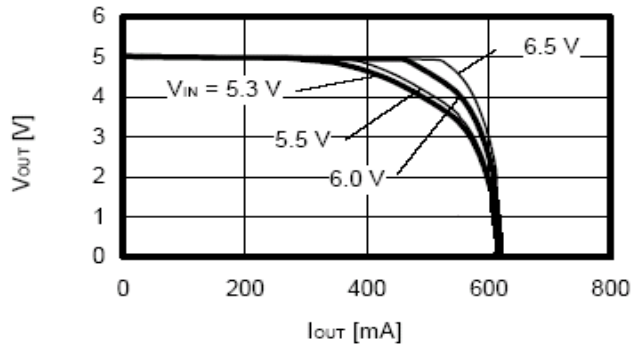

2. Output voltage vs. Input voltage

LN1130 (1.5V)

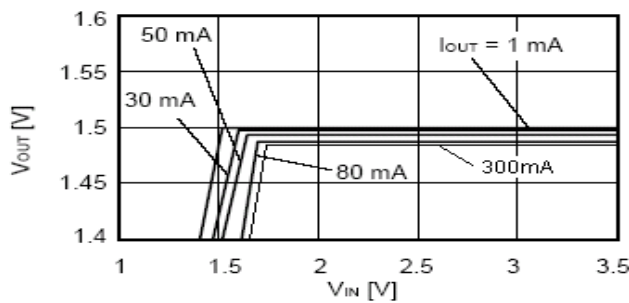

LN1130 (3.0V)

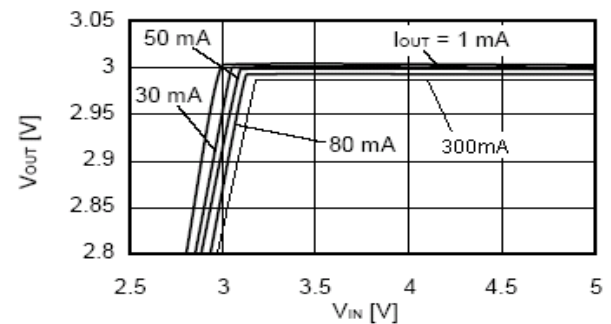

LN1130 (5.0V)

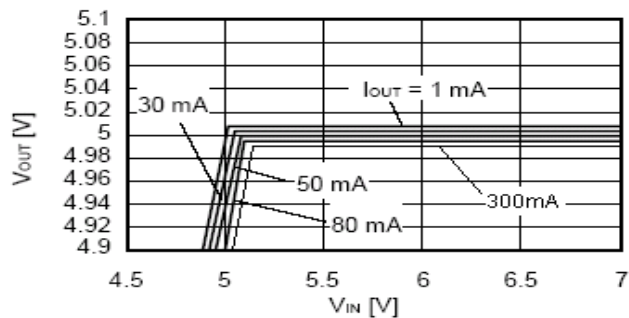

3、Dropout voltage vs. Output current

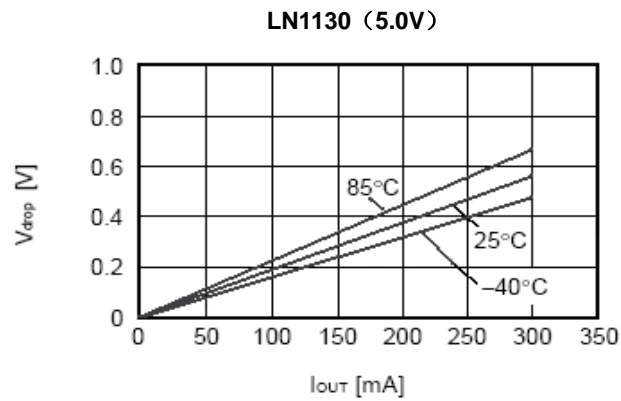
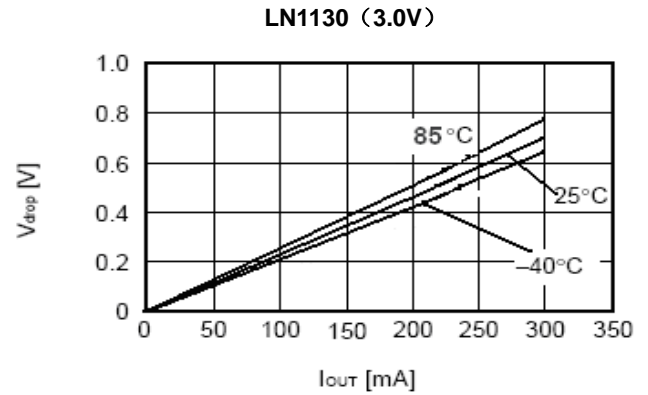
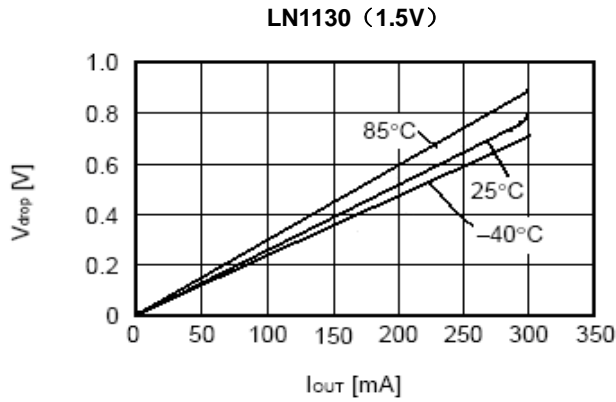

4、Dropout voltage vs. Set output voltage

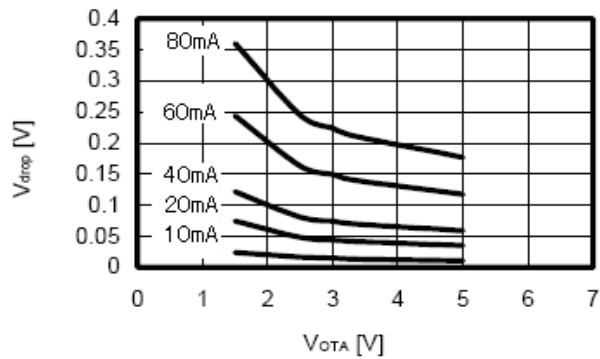

5、Output voltage vs. Ambient temperature

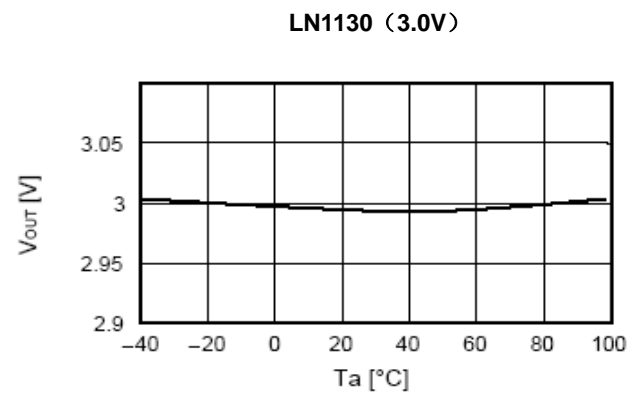
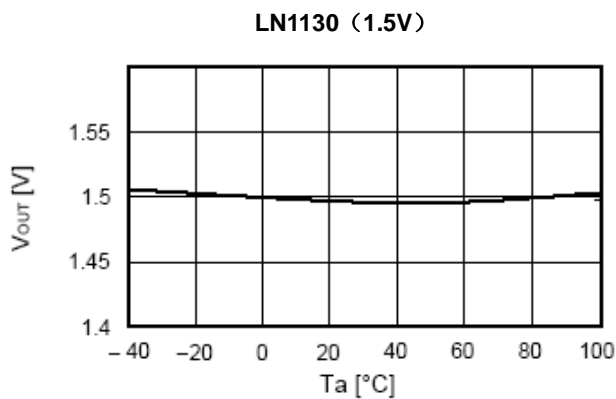

LN1130 (5.0V)

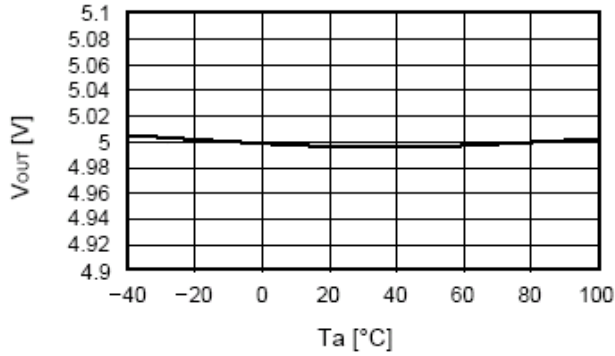

6. Ripple rejection

LN1130 (1.5V)

$V_{IN} = 2.5\text{ V}$, $C_{OUT} = 2.2\ \mu\text{F}$

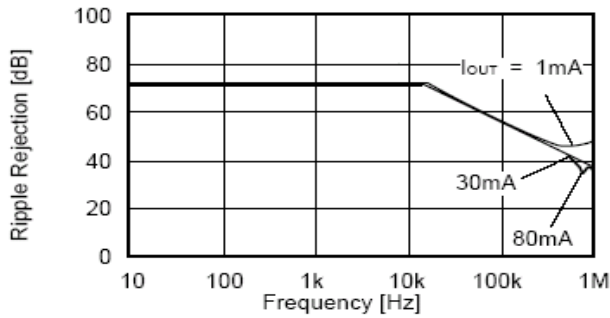

LN1130 (3.0V)

$V_{IN} = 4.0\text{ V}$, $C_{OUT} = 2.2\ \mu\text{F}$

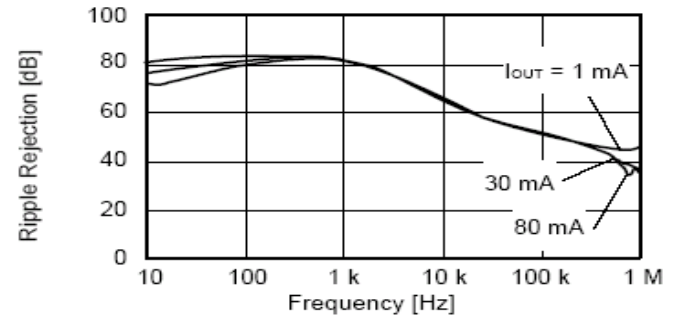

LN1130 (5.0V)

$V_{IN} = 6.0\text{ V}$, $C_{OUT} = 2.2\ \mu\text{F}$

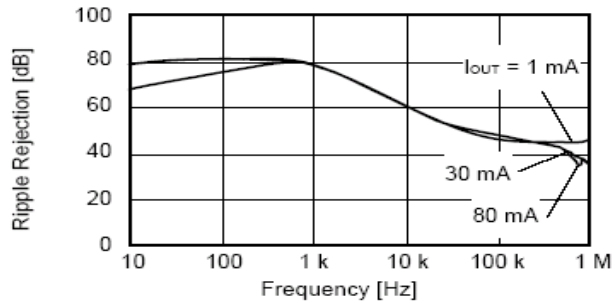

7. Transient response characteristics

Input transient response characteristics

$I_{OUT} = 80\text{ mA}$, $t_r = t_f = 5.0\ \mu\text{s}$, $C_{OUT} = 2.2\ \mu\text{F}$, $C_{IN} = 0\ \mu\text{F}$

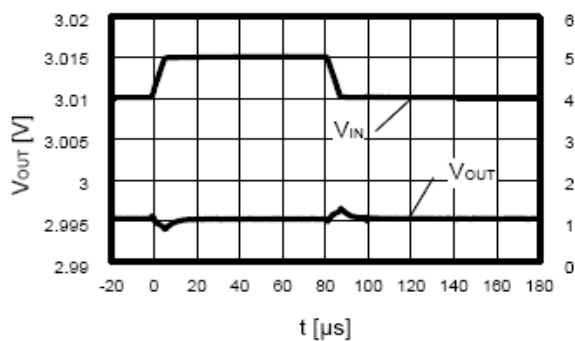

Load transient response characteristics

$V_{IN} = 4.0\text{ V}$, $C_{OUT} = 2.2\ \mu\text{F}$, $C_{IN} = 1.0\ \mu\text{F}$,
 $I_{OUT} = 50 \leftrightarrow 100\text{ mA}$

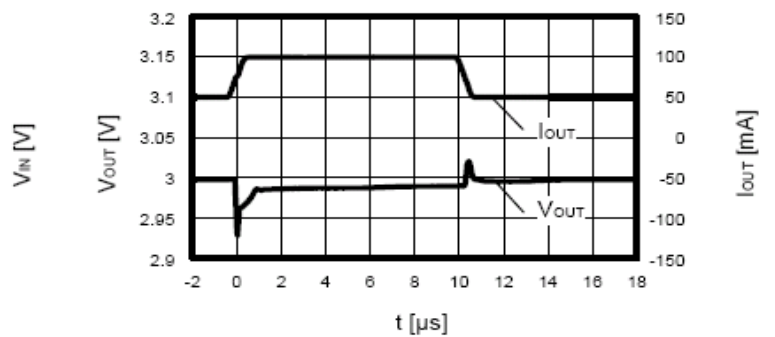

■ Package Information

- SOT-89-3L

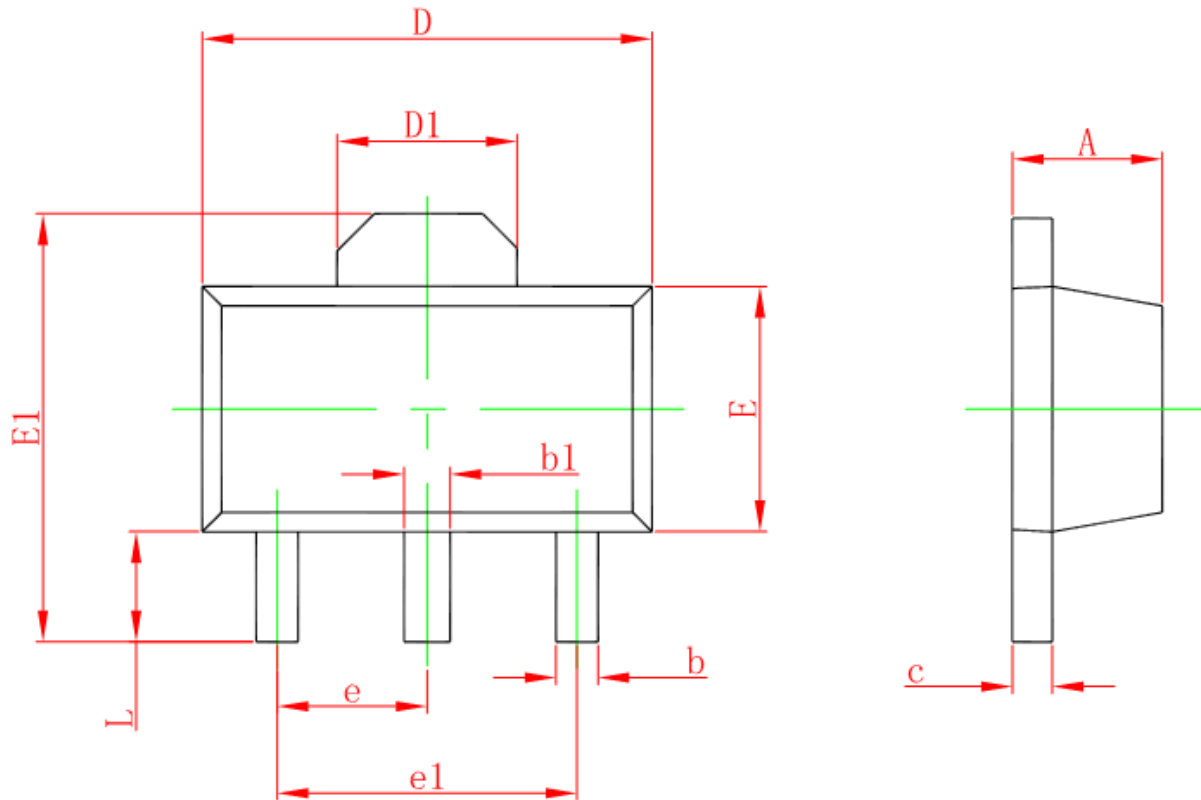

Symbol	Dimensions In Millimeters		Dimensions In Inches	
	Min	Max	Min	Max
A	1.400	1.600	0.055	0.063
b	0.320	0.520	0.013	0.020
b1	0.400	0.580	0.016	0.023
c	0.350	0.440	0.014	0.017
D	4.400	4.600	0.173	0.181
D1	1.550 REF.		0.061 REF.	
E	2.300	2.600	0.091	0.102
E1	3.940	4.250	0.155	0.167
e	1.500 TYP.		0.060 TYP.	
e1	3.000 TYP.		0.118 TYP.	
L	0.900	1.200	0.035	0.047

● SOT-23-3L

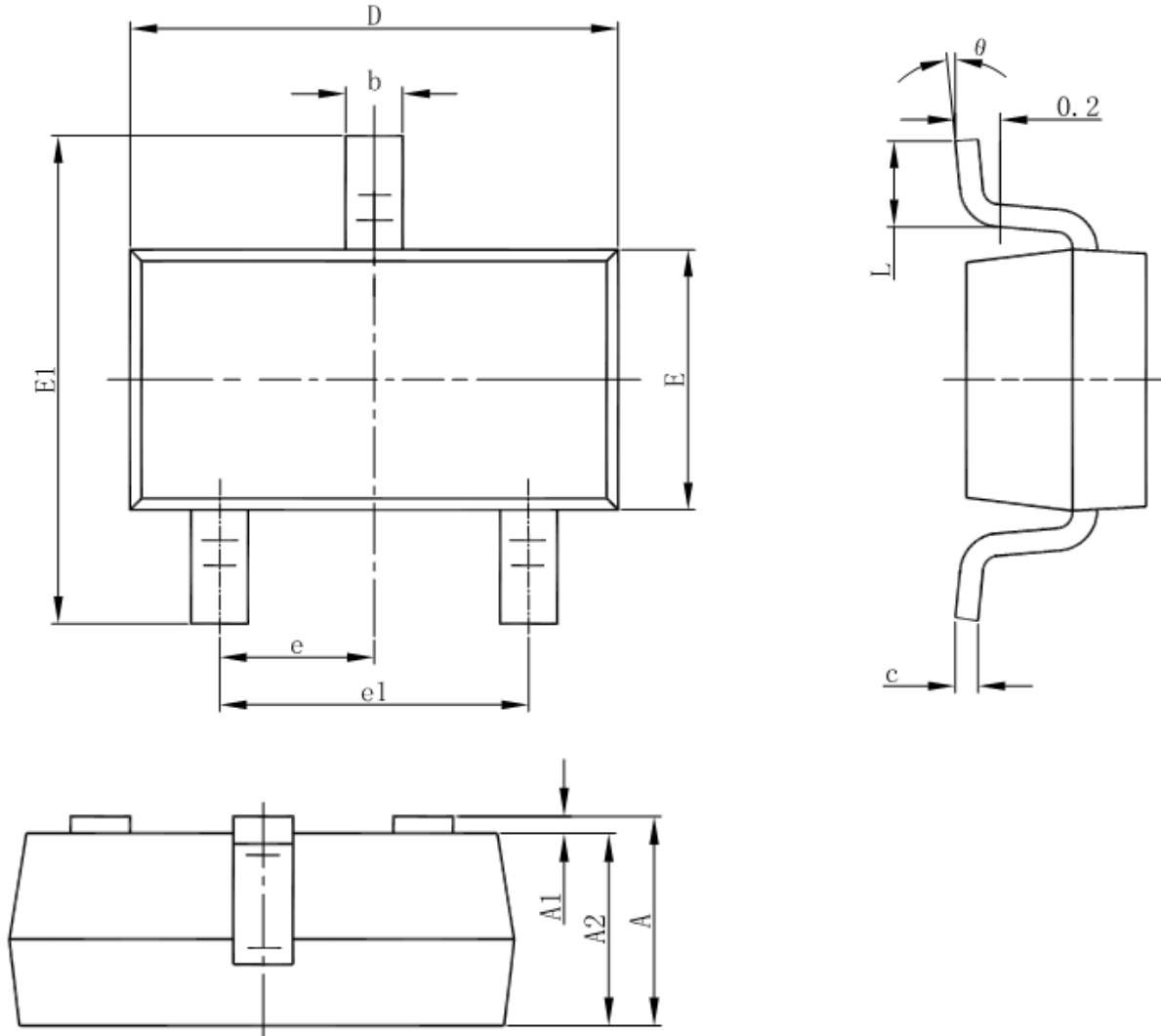

Symbol	Dimensions In Millimeters		Dimensions In Inches	
	Min	Max	Min	Max
A	1.050	1.250	0.041	0.049
A1	0.000	0.100	0.000	0.004
A2	1.050	1.150	0.041	0.045
b	0.300	0.500	0.012	0.020
c	0.100	0.200	0.004	0.008
D	2.820	3.020	0.111	0.119
E	1.500	1.700	0.059	0.067
E1	2.650	2.950	0.104	0.116
e	0.950(BSC)		0.037(BSC)	
e1	1.800	2.000	0.071	0.079
L	0.300	0.600	0.012	0.024
θ	0°	8°	0°	8°

● SOT-23-3B

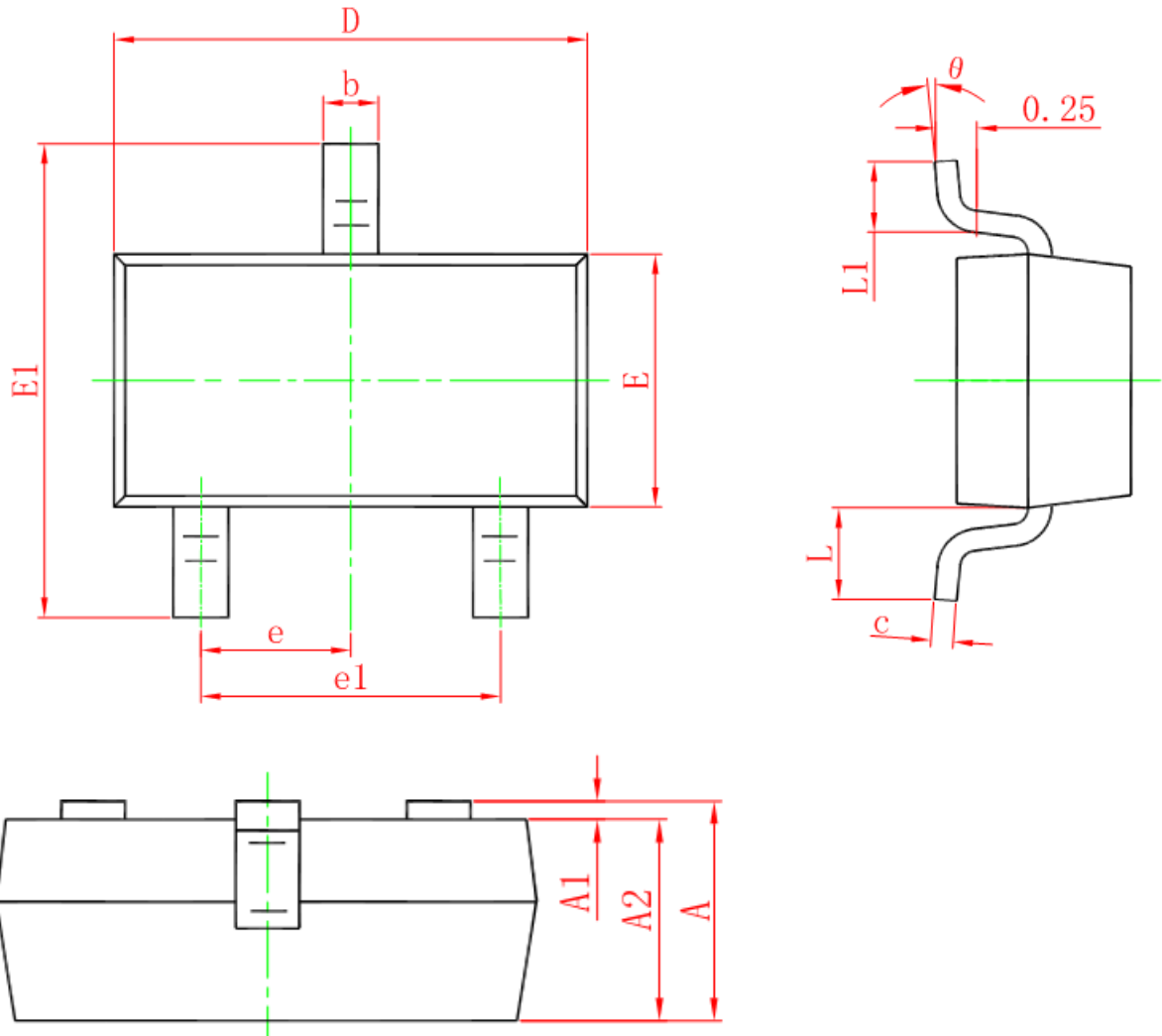

Symbol	Dimensions In Millimeters		Dimensions In Inches	
	Min.	Max.	Min.	Max.
A	0.900	1.150	0.035	0.045
A1	0.000	0.100	0.000	0.004
A2	0.900	1.050	0.035	0.041
b	0.300	0.500	0.012	0.020
c	0.080	0.150	0.003	0.006
D	2.800	3.000	0.110	0.118
E	1.200	1.400	0.047	0.055
E1	2.250	2.550	0.089	0.100
e	0.950 TYP.		0.037 TYP.	
e1	1.800	2.000	0.071	0.079
L	0.550 REF.		0.022 REF.	
L1	0.300	0.500	0.012	0.020
θ	0°	8°	0°	8°