

## Stereo 2.1W Non-Clip Audio Power Amplifiers

### General Description

The LN2012 is a digital audio power amplifier IC with maximum output of 2.1W ( $R_L=4\Omega$ ) $\times$ 2ch, which directly drives speakers while reducing distortion of pulse output signal and reducing noise on the signal, and realizes the highest standard low distortion rate characteristics and low noise characteristics.

The LN2012 detects output signal clip due to the over level input signal and suppress the output signal clip automatically. Also the non-clip output control function can adapt the output clip caused by power supply voltage down with battery. Attack time and release time can be freely set by external resistances or capacitances.

The independent power-down function for L channel and R channel minimizes consumption current at standby. As for protection function, short-current protection function for speaker output terminal, over-temperature protection function for inside of the device, and low supply voltage malfunction preventing function are prepared.

### Features

- Maximum output  
2.1 W $\times$ 2ch ( $V_{DDP}=V_{DDA}=5.0V$ ,  $R_L=4\Omega$ , THD+N=1%)  
0.75 W $\times$ 2ch ( $V_{DDP}=V_{DDA}=3.6V$ ,  $R_L=8\Omega$ , THD+N=10%)
- Distortion Rate (THD+N)  
0.03 % ( $V_{DDP}=V_{DDA}=3.6V$ ,  $R_L=8\Omega$ ,  $P_o=0.4W$ , 1kHz)
- Efficiency  
84 % ( $V_{DDP}=V_{DDA}=3.6V$ ,  $R_L=8\Omega$ ,  $P_o=600mW$ )
- Channel separation  
95dB ( $V_{DDP}=V_{DDA}=3.6V$ ,  $R_L=8\Omega$ ,  $A_v=18dB$ , 1kHz)
- Non-clip output
- 2ch independent power-down control function
- Thermal Protection function

### Ordering Information

Ordering Number	Package
LN2012SQ	QFNWB4 $\times$ 4-20L

### Applications

- Multimedia monitors
- Portable and desktop computers
- Portable televisions

### Package

- QFNWB4 $\times$ 4-20L

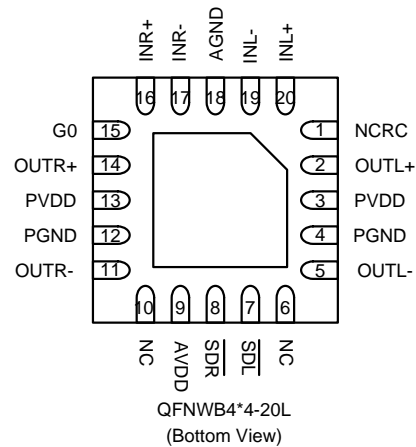

## Pin Configuration

No.	Name	I/O	Function
1	NCRC	I/O	Non-Clip control terminal
2	OUTL+	O	Positive output terminal (differential +) Lch
3	PVDD	Power	Power supply for output
4	PGND	GND	GND for output
5	OUTL-	O	Negative output terminal (differential -) Lch
6	NC		Non connection or connect to AGND
7	SDL	I	Shut-down terminal for Lch
8	SDR	I	Shut-down terminal for Rch
9	AVDD	Power	Power supply for analog circuits
10	NC		Non connection or connect to AGND
11	OUTR-	O	Negative output terminal (differential -) Rch
12	PGND	GND	GND for output
13	PVDD	Power	Power supply for output
14	OUTR+	O	Positive output terminal (differential +) Rch
15	G0	I	Gain setting terminal
16	INR+	A	Positive input terminal (differential +) Rch
17	INR-	A	Negative output terminal (differential -) Rch
18	AGND	GND	GND for analog circuits
19	INL-	A	Negative input terminal (differential -) Lch
20	INL+	A	Positive input terminal (differential +) Lch

(Note) I: Input terminal ; O: Output terminal ; A: Analog terminal.

## Function Block Diagram

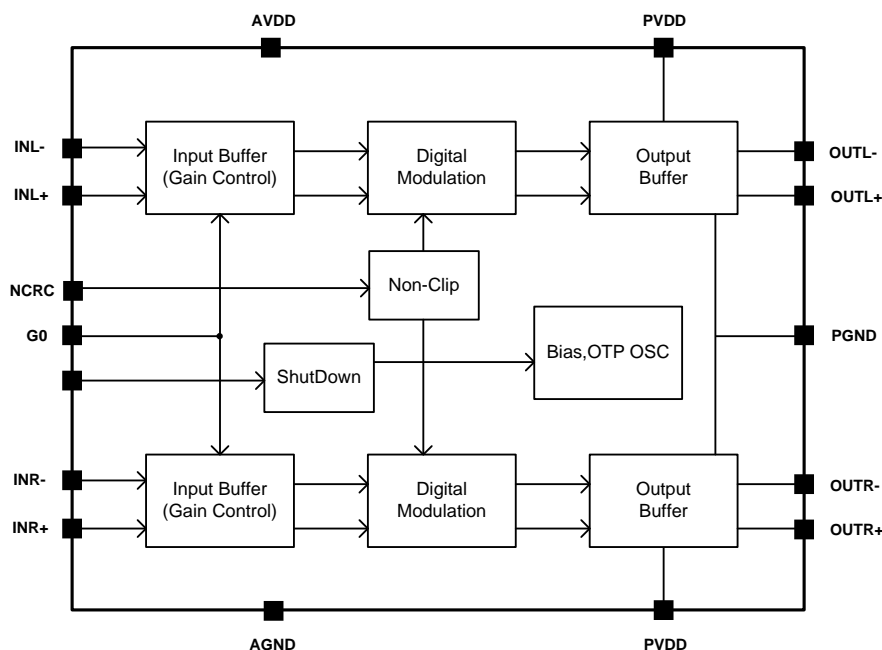

## ■ Operating Function

### ● First Stage Amplifier Gain Setting Function

G0 terminal can set the Gain of LN2012. When Non-Clip function is disabled, the relation between G0 terminal setting and Gain is as follows.

G0	Gain	Input Impedance( $Z_{in}$ )
L	12dB	44k $\Omega$
H	18dB	28k $\Omega$

### ● Non-Clip control Function

This is the function to control the output in order to obtain a maximum output level without distortion when an excessive input which causes clipping at the differential signal output is applied. LN2012 follows also to the clip of the output wave form due to the decrease in the power-supply voltage.

Connecting a resistor ( $R_{ex}$ ) and a capacitor ( $C_{ex}$ ) to NCRC terminal can set Attack Time and Release Time of the Non-Clip control.

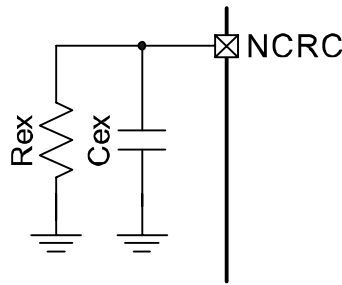

<b>Rex(M<math>\Omega</math>)</b>	1	4.7	1	1
<b>Cex(uF)</b>	1	1	0.47	4.7
<b>Attack Time (ms)</b>	10	10	4.7	47
<b>Release Time (s)</b>	0.8	3.8	0.38	3.8

## ■ Absolute Maximum Ratings

Parameter	Symbol	Min.	Max.	UNIT
PVDD Voltage Range	$V_{DDP}$	-0.3	6.0	V
AVDD Voltage Range	$V_{DDA}$	-0.3	6.0	V
Analog Input terminal Voltage Range	$V_{IN}$	-0.3	$V_{DDA}+0.3$	V
Junction Temperature	$T_{JMAX}$		125	$^{\circ}C$
Storage Temperature	$T_{STG}$	-50	125	$^{\circ}C$

## ■ Electrical Characteristics

### ● DC Characteristics

( $V_{DDP} = V_{DDA} = 2.7V$  to  $5.5V$ ,  $T_a = -40^{\circ}C$  to  $85^{\circ}C$ , unless otherwise specified)

Item	Symbol	Conditions	Min.	Typ.	Max.	Unit
AVDD consumption current	$I_{DD}$	$V_{DDA}=3.6$ , no load		6.0		mA
PVDD consumption current	$I_{DD}$	$V_{DDA}=3.6$ , no load No signal input		2.0		mA
Power-down current	$I_{PD}$	$SDL=SDR=0$			1	$\mu A$
SDL, SDR ,G0 H level input voltage	$V_{IH}$		1.35			V
SDL, SDR ,G0 L level input voltage	$V_{IL}$				0.35	V

### ● AC Characteristics

( $V_{DDP} = V_{DDA} = 2.7V$  to  $5.5V$ ,  $T_a = -40^{\circ}C$  to  $85^{\circ}C$ , unless otherwise specified)

Item	Symbol	Conditions	Min.	Typ.	Max.	Unit
Start-up time	$T_{STUP}$			3.5		ms
Input cut-off frequency	$f_c$	$C_{IN}=0.1\mu F$ , $A_V=18dB$		57		Hz
Attack time	$T_{AT}$	$V_{DDA}=3.6$ $A_V=10dB$ $C_{ex}=1\mu F$ , $R_{ex}=1M\Omega$		10		ms
Release time	$T_{RL}$	$V_{DDA}=3.6$ $A_V=10dB$ $C_{ex}=1\mu F$ , $R_{ex}=1M\Omega$		0.8		s
Carrier clock frequency	$f_{PWM}$			500		kHz

### ● Analog Characteristics

( $V_{DDP} = V_{DDA} = 3.6V$ ,  $T_a = 25^{\circ}C$ ,  $R_L = 8\Omega$ , Non-clip off ,unless otherwise specified)

Item	Symbol	Conditions	Min.	Typ.	Max.	Unit
Maximum output	$P_O$	$R_L=4\Omega$ $f=1kHz$ $THD+N=10\%$ $V_{DDA}=V_{DDP}=5$		2.1		W
Voltage Gain	$A_V$	G0=L		12		dB
		G0=H		18		
THD+Noise		$V_{DDA}=3.6$ $A_V=10dB$ $C_{ex}=1\mu F$ , $R_{ex}=1M\Omega$		0.03		%
PSRR		217Hz to PVDD		-85		dB
Non-Clip maximum attenuation gain	$A_a$			-10		dB

## Typical Application Circuit

### Application 1. ( $2.7V \leq PVDD \leq 4.5V$ )

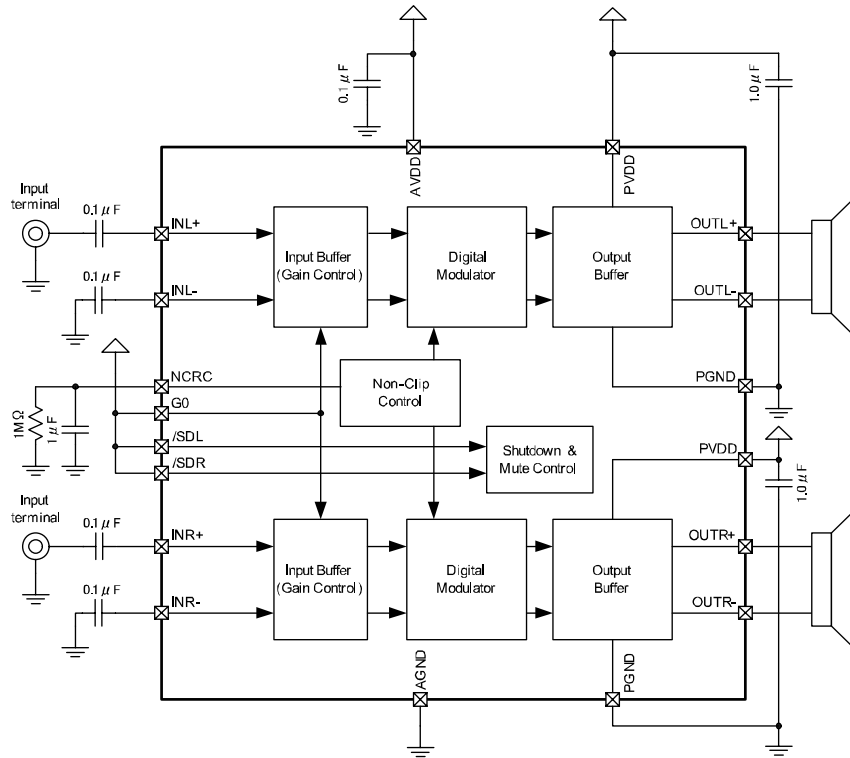

### Application 2. ( $4.5V \leq PVDD$ )

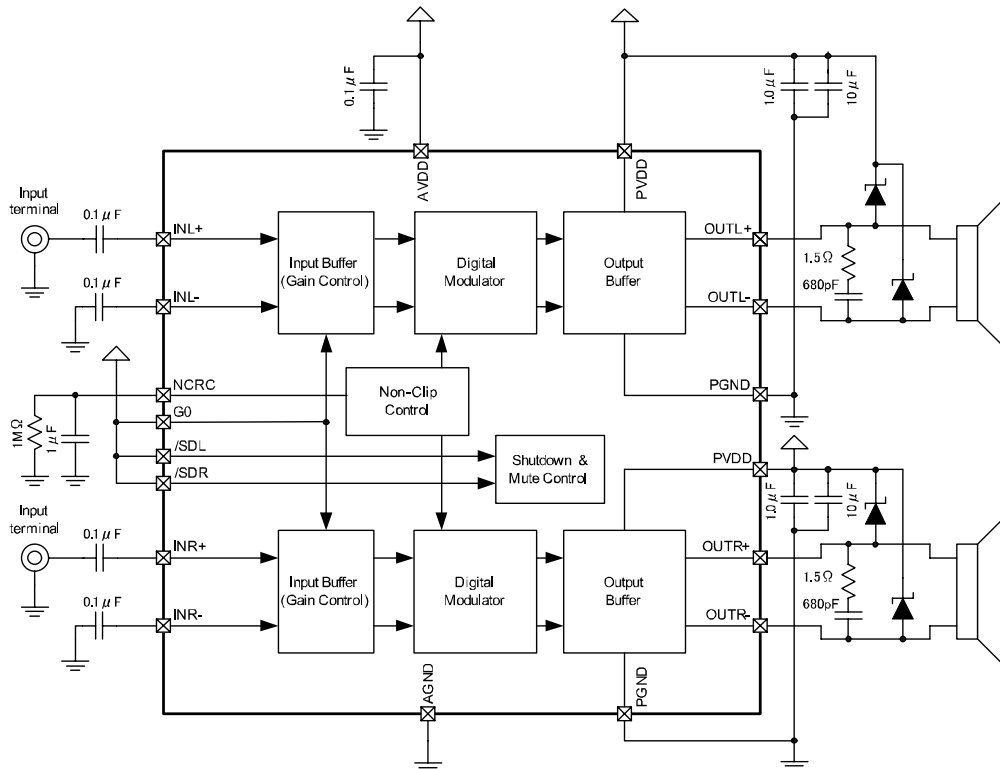

■ Package Information

- QFNWB4×4-20L

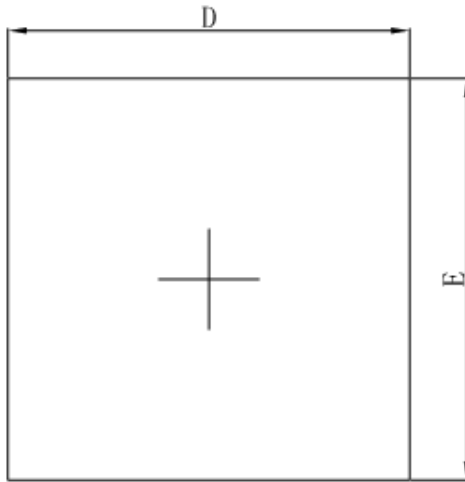

Top View

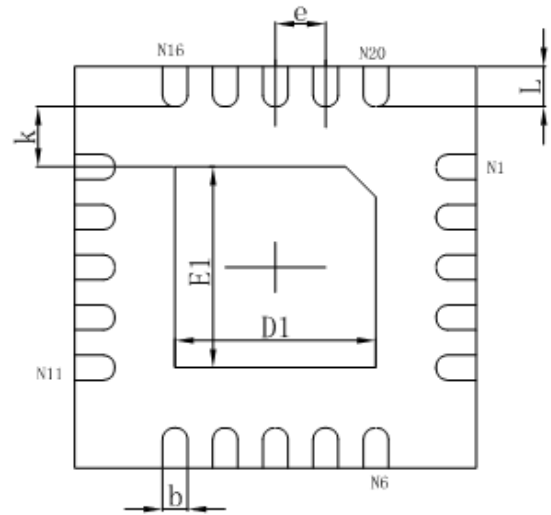

Bottom View

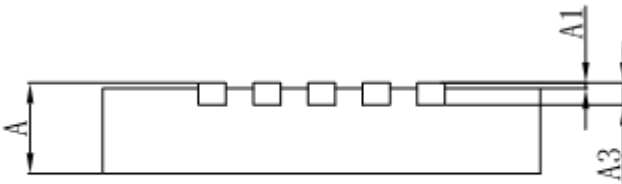

Side View

Symbol	Dimensions In Millimeters		Dimensions In Inches	
	Min.	Max.	Min.	Max.
A	0.700/0.800	0.800/0.900	0.028/0.031	0.031/0.035
A1	0.000	0.050	0.000	0.002
A3	0.203REF.		0.008REF.	
D	3.900	4.100	0.154	0.161
E	3.900	4.100	0.154	0.161
D1	1.900	2.100	0.075	0.083
E1	1.900	2.100	0.075	0.083
k	0.200MIN.		0.008MIN.	
b	0.180	0.300	0.007	0.012
e	0.500TYP.		0.020TYP.	
L	0.300	0.500	0.012	0.020