

1A is compatible with the USB interface, linear battery management chip

■ General Description

The LN2053 is a constant-current / constant-voltage charger circuit for single cell lithium-ion batteries. The device includes an internal power transistor, does not need external current sense resistor and blocking diode in applications. LN2053 requires minimal external components, and meet the USB bus specification, is very suitable for portable applications in the field.

Thermal modulation circuit can control the chip temperature in a safe range when the device power dissipation is relatively large or the ambient temperature is higher. Within a fixed constant charge voltage 4.2V, can also be adjusted by an external resistor. Charge current set by an external resistor.

When the input voltage (AC adapter or USB power supply) power is lost, LN2053 automatically enters a low power sleep mode, and then the battery current consumption is less than 3 μ A. Built-in protection circuits against irrigation, when the battery voltage is higher than the input voltage, automatically turn off built-in power MOSFET. Other features include low input voltage latch, automatic recharge, the battery temperature protect and charge status / charge status indication functions. LN2053 uses thermally enhanced 8-pin small outline package eOP-8.

■ Applications

- Mobile phones
- Digital cameras
- MP4 player
- Bluetooth applications
- Electronic dictionary

■ Ordering Information

LN2053①②③④⑤

Designator	Description	Symbol	Description
①	Type	Y	Have trickle charge
②	The output voltage of regulator	2	4.2/3.65V
④	Packaging Types	S	eSOP-8
⑤	Device Orientation	R	Standard feed
		L	Reverse feed

- Portable devices
- All kinds of charger

■ Features

- Programmable charge current up to 1A
- No MOSFET, sense resistor or blocking diode required
- Complete linear charger in small package for single cell lithium-ion batteries
- Constant-current/constant-voltage operation with thermal regulation to maximize charge rate without risk of overheating
- Charges single cell li-ion batteries directly from USB port
- Preset 4.2V charge voltage with $\pm 1\%$ accuracy, also can be adjusted by FB
- Monitor output charge current
- Automatic recharge
- Charge status output pin
- 1/10 charge current termination
- 25 μ A supply current in shutdown
- 2.9V trickle charge threshold
- Soft-Start limits inrush current
- Output with protection against anti-irrigation
- Available in SOP-8 Package

■ Package

- eSOP-8

■ Marking Rule

- eSOP-8

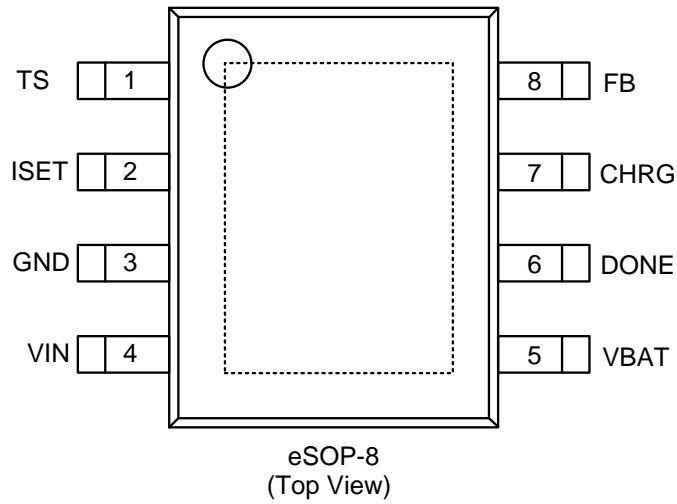

■ Package Type

- eSOP-8

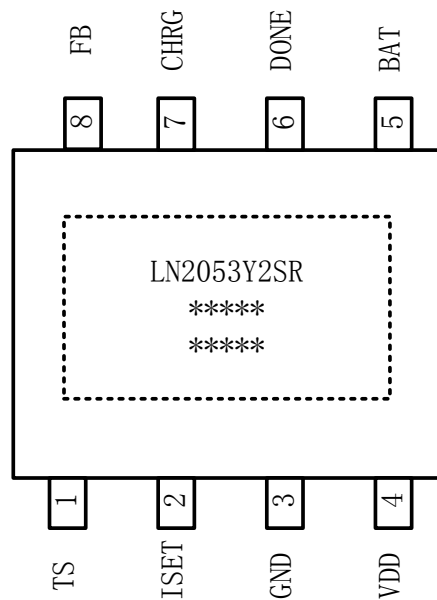

*****: There are defined inside the company, as the quality of the tracking information

■ Pin Configuration

Pin No.	Pin Name	Pin No.	Pin Name
1	TS	5	VBAT
2	ISET	6	$\overline{\text{DONE}}$
3	GND	7	$\overline{\text{CHRG}}$
4	VIN	8	FB

■ Pin Function

- **TS (Pin 1):** The TS pin to the battery of the NTC sensor output. If the TS pin voltage is less than the input voltage of 30% or greater than 60% of the input voltage means the battery temperature is too low or too high, then the charge will be suspended. If the TS input voltage between 30% and 60%, then the battery fault condition will be cleared, the charge will continue. Battery temperature sensing feet, when not use , please contact GND.
- **ISET (Pin 2):** Charge current programming, charge current monitoring and close pin. Charge current is controlled by a resistor of precision of 1%to the ground. In the constant charge current state, this port provides 1V voltage. In all conditions, this port charge current can be calculated using the following formula:

$$IBAT = (V_{ISET}/R_{ISET}) \times 1250$$

ISET port can also be used to turn off the charger. Resistance to side with the separation of programming can pull the 3 μ A current source to increase ISET port voltage. When the suspension reached the limit voltage 1.21V, the device enters stop state, after charging the input current drop to 25 μ A. This port pinch-off voltage is about 2.4V. If supply this port voltage more than pinch-off voltage, the current will be 1.5 mA. Through combinating ISET pin to the ground, the charger will back to normal.

- **GND (Pin 3):** Ground terminal
- **VIN (Pin 4):** Supply positive input voltage. Power supply for the charger. VCC can be 4.25V to 6.5V and must have at least 1F bypass capacitor. If the BAT pin voltage of VCC down to within 30 mV, LN2052 into the suspension state, and make BAT Current less than 2A.
- **BAT (Pin 5):** Make the battery's positive terminal connected to this pin. When the power supply voltage lower than the threshold latch voltage or sleep mode voltage, BAT pin current is less than 2 μ A. BAT pin provide the battery charge current and constant voltage charging voltage.
- **DONE (Pin 6):** When charging end, DONE pin is pulled low by internal switch represents that charge has ended; otherwise DONE pin is high impedance state.
- **CHRG (Pin 7):** When the charger to the battery charging, CHRG pin is pulled low by the internal switch,represents charging being; otherwise CHRG pin is in high impedance state.
- **FB (Pin 8):** This pin foot iron phosphate power battery access. When FB and BAT shorted, the output is 3.65V. If connect a resistor between the FB pin and BAT pin, constant charging voltage can be adjusted.

■ Block Diagram

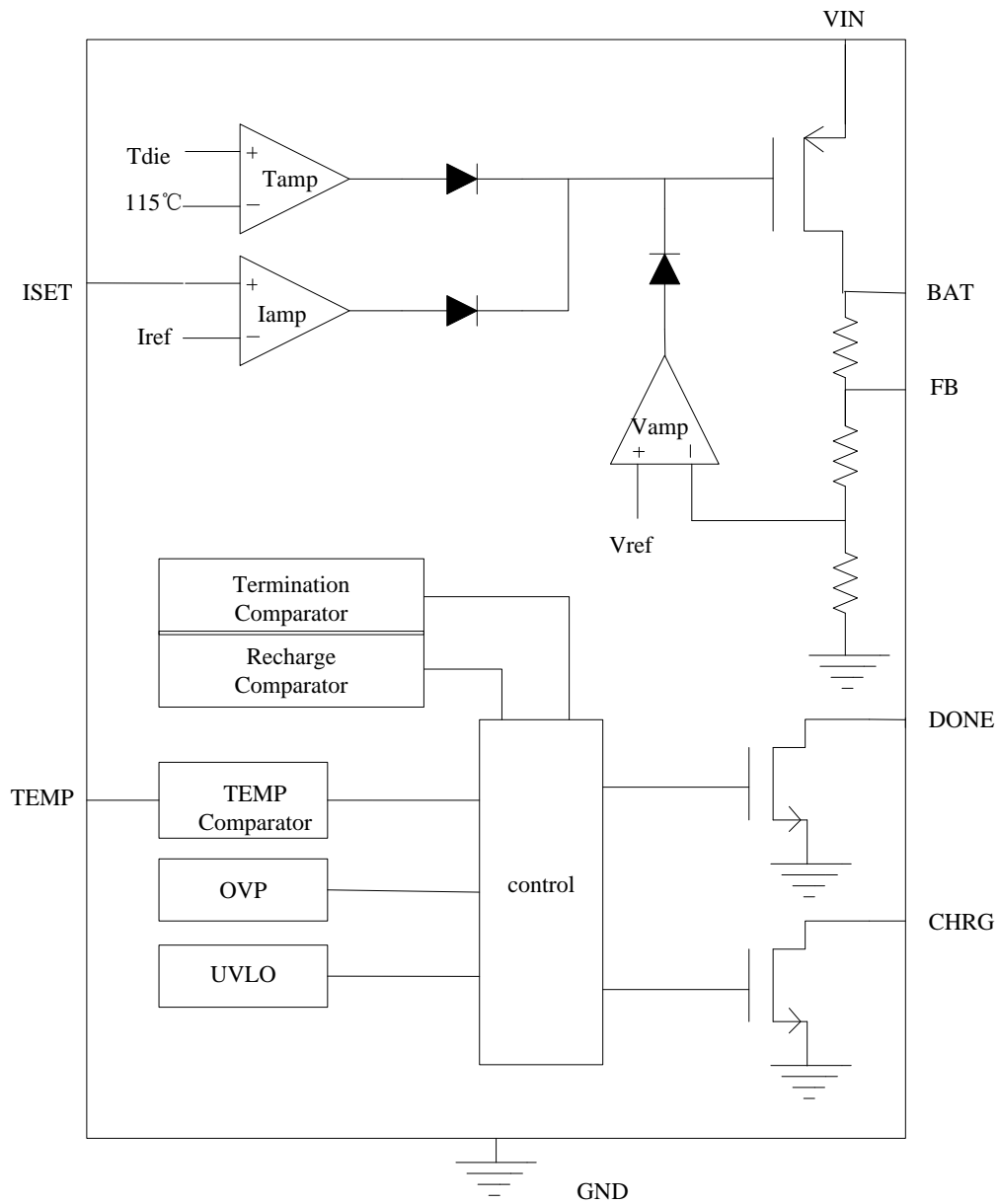

Figure1.

Absolute Maximum Ratings

Parameter	Symbol	Maximum Rating	Unit
Input supply voltage	V_{cc}	$V_{SS}-0.3 \sim V_{SS}+7$	V
ISET pin Voltage	V_{prog}	$V_{SS}-0.3 \sim V_{cc}+0.3$	
BAT pin Voltage	V_{bat}	$V_{SS}-0.3 \sim 6$	
DONE pin Voltage	V_{done}	$V_{SS}-0.3 \sim V_{SS}+7$	
CHAG pin Voltage	V_{chg}	$V_{SS}-0.3 \sim V_{SS}+7$	
ESD discharge capability	Hbm	3000	
BAT pin current	I_{bat}	1500	mA
ISET pin current	I_{prog}	1500	uA
Operating ambient temperature	T_{opa}	-40~+85	°C
Storage temperature	T_{str}	-65~+125	
Pin soldering temperature(10s)	-	300	

Caution: The absolute maximum ratings are rated values exceeding which the product could suffer physical damage. These values must therefore not be exceeded under any conditions.

Typical Application Circuit

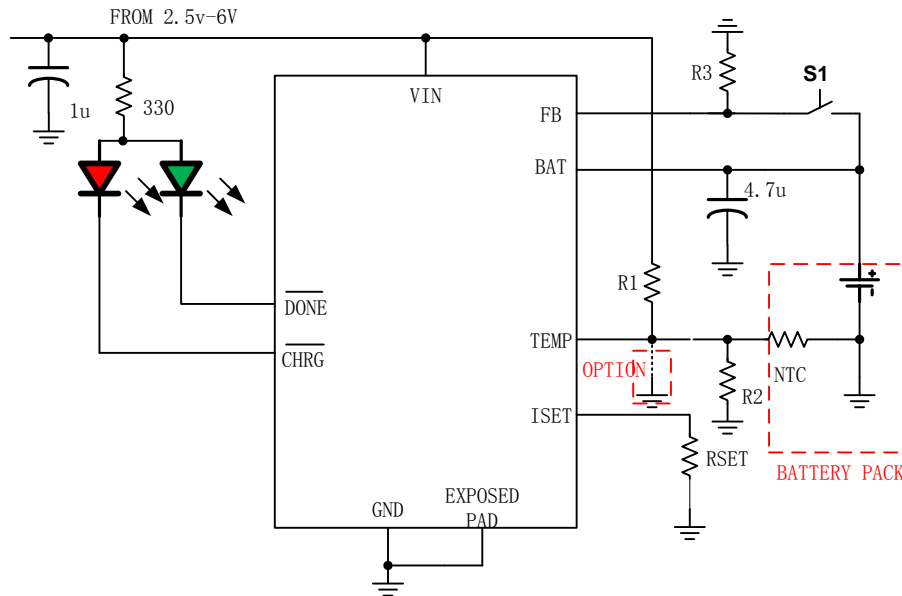

Figure2.

■ Electrical Characteristics

- Li-ion Battery version: (TA=25°C unless otherwise noted)

Parameter	Symbol	Condition	Min	Typ	Max	Unit
Input supply voltage	Vcc		4		6.5	V
Input supply current	Icc	Charge mode, Riset=10K		200	2000	uA
		Standby mode		200	500	uA
		Shutdown mode (Riset not connected, Vcc < Vbat or Vcc < Vuv)		25	50	uA
Regulated Output Voltage	Vfloat	0°C ≤ TA ≤ 85°C, IBAT=40mA	4.16	4.2	4.25	V
BAT pin Current	Ibat	Riset=10k, Current mode	93	100	140	mA
		Riset=1k, Current mode	930	1000	1070	mA
		Riset=660, Current mode	1400	1500	1600	mA
		Standby mode, Vbat=4.2V	0	-2.5	-6	uA
		Shutdown mode		1	2	uA
		Sleep mode, Vcc=0V		1	2	uA
Trickle charge current	Itrikl	Vbat < Vtrikl, Rprog=2k	75	100	125	mA
Trickle charge Threshold Voltage	Vtrikl	Riset=10K, Vbat Rising	2.8	2.9	3.0	V
Trickle voltage hysteresis voltage	Vtrhys	Riset=10k	60	80	110	mV
Vcc Undervoltage lockout Threshold	Vuv	From Vcc low to high	2.9	3.0	3.1	V
Vcc undervoltage lockout hysteresis	Vuvhys		50	80	100	mV
Manual shutdown threshold voltage	Vmsd	Iset pin rising	1.15	1.21	1.30	V
		Iset pin falling	0.9	1.0	1.1	V
Vcc-Vbat Lockout Threshold voltage	Vasd	Vcc from low to high	70	100	140	mV
		Vcc from high to low	5	30	50	mV
C/10 Termination Current Threshold	Iterm	Riset=10k	0.085	0.10	0.115	mA
		Riset=2k	0.085	0.10	0.115	mA
PROG pin Voltage	Vprog	Riset=10k, Current mode	0.93	1.0	1.07	V
CHRG pin Output low voltage	Vdone	Idone=5mA		0.35	0.6	V
CHRG pin Output low voltage	Vchrg	Ichrg=5mA		0.35	0.6	V
Recharge Battery threshold Voltage	Δ Vrecg	VFLOAT - VRECHRG		300	400	mV

● Lithium iron phosphate battery version: (TA=25°C unless otherwise noted)

Parameter	Symbol	Condition	Min	Typ	Max	Unit
Input supply voltage	Vcc		4		6.5	V
Input supply current	Icc	Charge mode, Riset=10K		200	2000	uA
		Standby mode		200	500	uA
		Shutdown mode (Riset not connected, Vcc < Vbat or Vcc < Vuv)		25	50	uA
Regulated Output Voltage	Vfloat	0°C ≤ TA ≤ 85°C, IBAT=40mA	3.6	3.65	3.7	V
BAT pin Current	Ibat	Riset=10k, Current mode	93	100	140	mA
		Riset=1k, Current mode	930	1000	1070	mA
		Riset=660, Current mode	1400	1500	1600	mA
		Standby mode, Vbat=3.65V	0	-2.5	-6	uA
		Shutdown mode		1	2	uA
		Sleep mode, Vcc=0V		1	2	uA
Trickle charge current	Itrikl	Vbat < Vtrikl, Rprog=2k	20	45	70	mA
Trickle charge Threshold Voltage	Vtrikl	Riset=10K, Vbat Rising	2.4	2.5	2.6	V
Trickle voltage hysteresis voltage	Vtrhys	Riset=10k	60	80	110	mV
Vcc Undervoltage lockout Threshold	Vuv	From Vcc low to high	2.9	3.0	3.1	V
Vcc undervoltage lockout hysteresis	Vuvhys		50	80	100	mV
Manual shutdown threshold voltage	Vmsd	Iset pin rising	1.15	1.21	1.30	V
		Iset pin falling	0.9	1.0	1.1	V
Vcc-Vbat Lockout Threshold voltage	Vasd	Vcc from low to high	70	100	140	mV
		Vcc from high to low	5	30	50	mV
C/10 Termination Current Threshold	Iterm	Riset=10k	0.085	0.10	0.115	mA
		Riset=2k	0.085	0.10	0.115	mA
PROG pin Voltage	Vprog	Riset=10k, Current mode	0.93	1.0	1.07	V
CHRG pin Output low voltage	Vdone	Idone=5mA		0.35	0.6	V
CHRG pin Output low voltage	Vchrg	Ichrg=5mA		0.35	0.6	V
Recharge Battery threshold Voltage	Δ Vrecg	VFLOAT - VRECHRG		250	350	mV

Application Information

● Kelvin battery voltage detection

When FB and BAT shorted, the output is 3.65V. When FB and BAT opened, the output is 4.2V. If connect a resistor between the FB pin and BAT pin, the output can be regulated from 3.65V to 4.2V.

● Adjust the constant charging voltage

If connect a resistor between the LN2053 battery voltage Kelvin test input pin (FB) and the positive battery , it can increase the battery charging voltage, as shown in Figure 3, then the positive battery voltage Vbat is:

$$V_{bat} (V) = \frac{1.2}{305} * \frac{142.5}{142.5 + R_x} * R_x + 3.65$$

When using an external resistor to adjust the charging voltage constant, due to internal and external temperature of chip and chip production inconsistent with the process variation and other factors, may cause the accuracy of the output voltage variation and temperature coefficient.

● Application of USB and AC adapter while charging at the same time

LN2053 can not only use USB interface to charge the battery, users can also use a wall adapter to charge the battery. Figure 3 shows the same time using the USB interface and the AC adapter to charge the battery through the LN2053 .when the two co-exist, the AC adapter has priority. M1 is the P-channel MOSFET, M1 is used to prevent current from a wall adapter into the USB interface, USB interface, Schottky diode D1 prevents the consumption of energy through the 1K resistor.

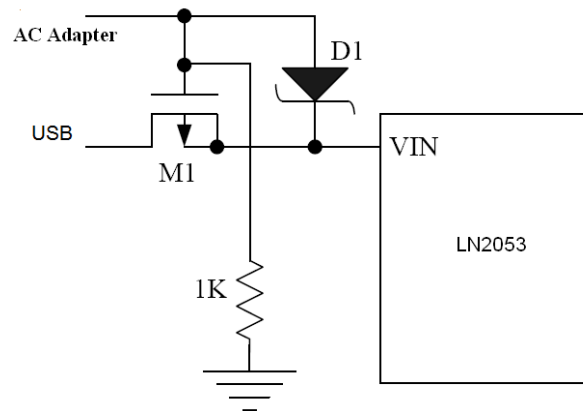

Figure3. While using the AC adapter and USB interfaces

● Set the charge current

In constant-current mode, formula for calculating charge current: $I_{CH} = 1250V / R_{ISET}$

I_{CH} represents the charge current, units is ampere, R_{ISET} represents ISET pin to ground resistance in ohms. For example, if you need 500mA charge current, according to the following formula: $R_{ISET} = 1250V/0.5A = 2.5k\Omega$

In order to ensure good stability and temperature characteristics, R_{ISET} recommend the use of 1% precision metal film resistors. By measuring the ISET pin voltage can be detected charge current. Charge current can be calculated using the following formula: $I_{CH} = (V_{ISET} / R_{ISET}) \times 1250$

● Battery temperature monitoring

In order to prevent the battery temperature is too high or too low on the battery damage, LN2053 internal battery temperature monitoring of integrated circuits. Battery temperature monitoring is by measuring the TEMP pin voltage to achieve,

TEMP pin voltage is within the battery NTC thermistor and a resistor divider network, and illustrated in Figure 2.

LN2053 the TEMP pin voltage with the chip and the two thresholds VLOW VHIGH compared to confirm whether the battery temperature exceeds the normal range. In the LN2053, VLOW were fixed in $30\% \times V_{IN}$, VHIGH were fixed in $60\% \times V_{IN}$. If the TEMP pin voltage $V_{TEMP} < V_{LOW}$ or $V_{TEMP} > V_{HIGH}$, the battery temperature is too high or too low, charging will be suspended; If the TEMP pin voltage V_{TEMP} VLOW and VHIGH in between, the charge cycle will continue.

- **Enable design**

By controlling whether the ISET pin resistor connected, users can reach close LN2053 function. Figure 4:

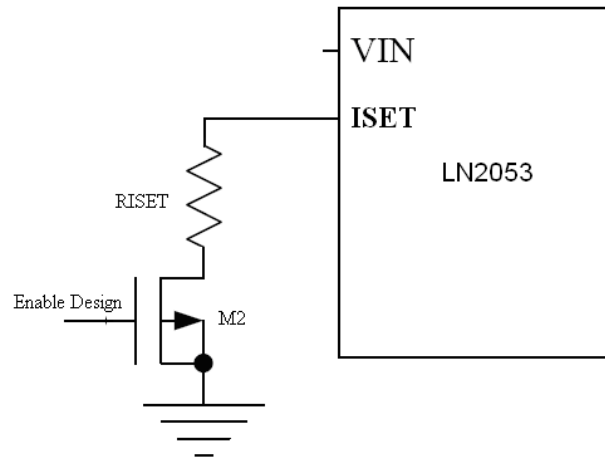

Figure4. LN2053 Enable Design

- **Open-drain output status indication**

LN2053has two open-drain status indication sides, CHAG and DONE, the two status indicator LEDs client can drive or microcontroller port. CHAG used to indicate charging status, charging time, CHAG is low; DONE to indicate the charging end of the state, when the charging end, DONE is low. When the battery temperature is outside the normal temperature range more than 0.15 seconds, CHAG and the DONE pin is high impedance output state.

When the battery charger not received, the charger will quickly charge the output capacitor to the constant voltage value, as the battery voltage detection Kelvin FB pin input leakage current, FB pin and the BAT pin voltage will slowly down to recharge threshold, so the FB pin and the BAT pin voltage is 150mv to form a ripple waveform, while CHAG output pulse signal that there is no battery installed. When the battery BAT pin external connectors for the 4.7uF capacitor, the pulse period of about 2Hz. The following table lists CHAG and the DONE pin status in each case:

State	Charge	Full	Without Battery	Error
CHAG	Always bright	Always off	Flashing	Always off
DONE	Always off	Always bright	Always bright	Always off

- Note:**
1. CHAG flicker frequency with external capacitor when not connect battery, generally recommended 4.7uF.The greater the capacitance, the smaller frequency flicker.
 2. The error situation: Beyond the operating temperature range (temperature too high or too low), Iset side vacant, Vin $< V_{bat}$, Vin $< 3.8V$ and so on.

■ Package Information

- eSOP-8

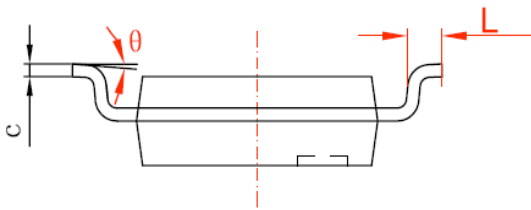
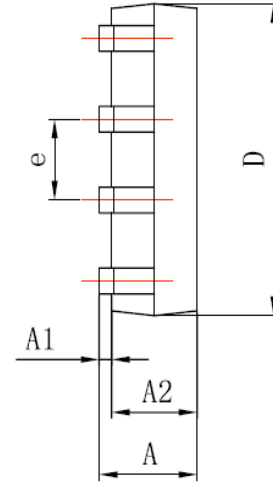
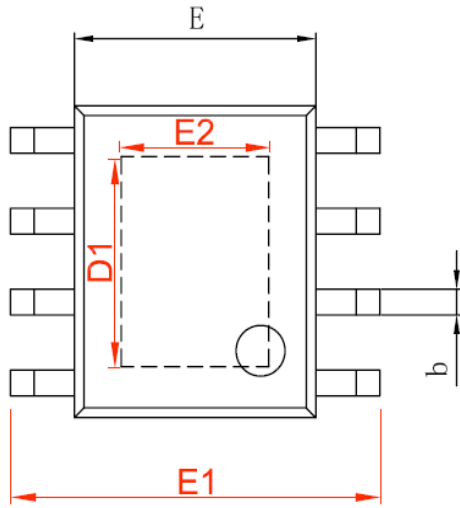

字符	Dimensions In Millimeters		Dimensions In Inches	
	Min	Max	Min	Max
A	1.350	1.750	0.053	0.069
A1	0.050	0.150	0.002	0.006
A2	1.350	1.550	0.053	0.061
b	0.330	0.510	0.013	0.020
c	0.170	0.250	0.007	0.010
D	4.700	5.100	0.185	0.200
D1	3.202	3.402	0.126	0.134
E	3.800	4.000	0.150	0.157
E1	5.800	6.200	0.228	0.244
E2	2.313	2.513	0.091	0.099
e	1.270 (BSC)		0.050 (BSC)	
L	0.400	1.270	0.016	0.050
θ	0°	8°	0°	8°