

Step-up DC/DC Converter —Backlight Driver

General Description

The LN2117 Series is a fixed frequency, constant current step-up DC/DC converter ideal for driving LEDs used in backlighting applications on cellular phones, PDAs and digital cameras etc. Output voltage of up to 20V can be derived, and from a 3.2V input four white Led's cab be driven in series or alternatively, using a 3.0V input, a network of six LEDs may be driven. Luminance of the LED's is controlled by changing the duty cycle of a PWM signal applied to the CE pin.

Features

- Input voltage range 2.5V—6V
- Output voltage range up to 20V
- Oscillation frequency 1MHz±20%
- Efficiency 88%(When driving 3 white LEDs in series VIN=3.6V ILED=20mA)
- Control PWM control
- Stand-by Current ISTB=1.0uA(MAX)
- Load capacitor 0.22uF,ceramic
- LX limit Current 300mA

Ordering Information

LN2117 ①②③④⑤⑥

Item	Symbol	Function
①	B	Denotes Lx Overvoltage Limit: Yes Denotes Oscillation Frequency:1MHZ
②③④	010-149	Denotes FB Voltage e.g. ②=1 ③=2 ④=3 1.23V
⑤	M	Denotes Package Type : SOT-23-6L
⑥	R	Embossed Tape :Standard Feed
	L	Embossed Tape :Reverse Feed

Applications

- For White LED Drivers
- Mobil phones, PHS
- PDAs
- Digital still cameras

Package

- SOT-23-6L

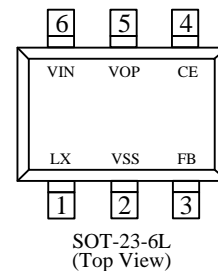

Typical Application Circuit

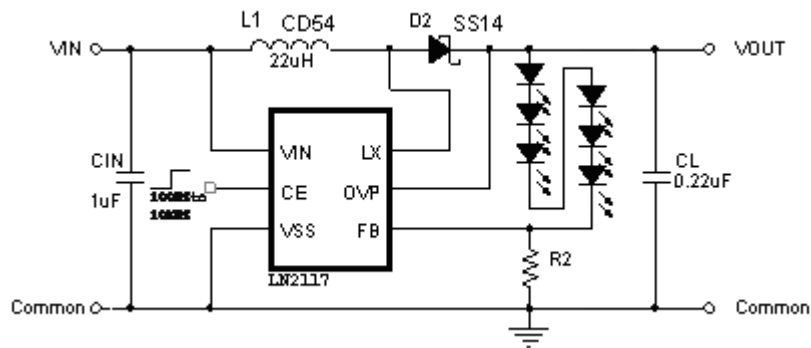
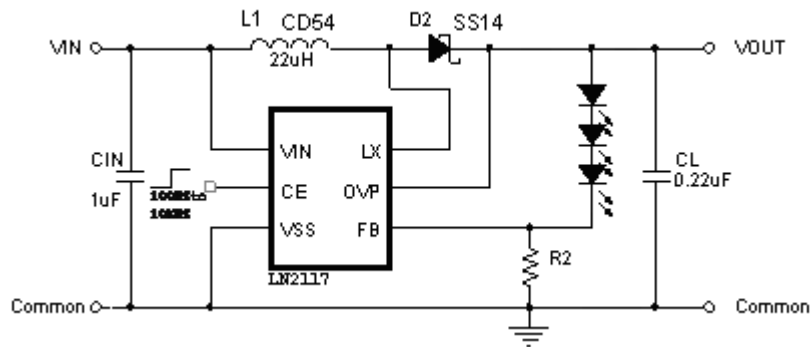

Caution The value of the resistance named RLED: $R2 = V_{FB} / I_{LED}$; V_{FB} is the voltage of the FB pin; I_{LED} is the current of LED and equal to 20mA usually.

Functional Pin Description

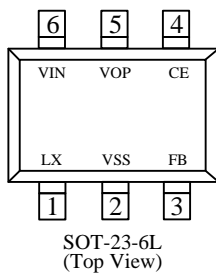

Pin Number	Pin Name	Function
1	LX	SWITCH
2	VSS	Ground
3	FB	Voltage Feedback
4	CE	Chip Enable
5	OVP	Over voltage protect
6	VIN	Power Input

Marking Rule

- SOT-23-6L

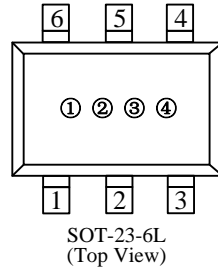

① Represents the product name

Symbol	Part Number
Z	LN2117****M*

② ③ Represents the voltage of FB pin and the type of regulator

Symbol	Vfb(V)
AA	100mV
B0	200mV
B3	230mV
B5	250mV

③ Represents t

Symbol	Vfb(V)			Symbol	Vfb(V)		
0	0.20	0.050	1.20	F	0.35	0.125	1.35
1	0.21	0.055	1.21	H	0.36	0.130	1.36
2	0.22	0.060	1.22	K	0.37	0.135	1.37
3	0.23	0.065	1.23	L	0.38	0.140	1.38
4	0.24	0.070	1.24	M	0.39	0.145	1.39
5	0.25	0.075	1.25	N	0.40	0.150	1.40
6	0.26	0.080	1.26	P	0.41	0.155	1.41
7	0.27	0.085	1.27	R	0.42	0.160	1.42
8	0.28	0.090	1.28	S	0.43	0.165	1.43
9	0.29	0.095	1.29	T	0.44	0.170	1.44
A	0.30	0.100	1.30	U	0.45	0.175	1.45
B	0.31	0.105	1.31	V	0.46	0.180	1.46
C	0.32	0.110	1.32	X	0.47	0.185	1.47
D	0.33	0.115	1.33	Y	0.48	0.190	1.48
E	0.34	0.120	1.34	Z	0.49	0.195	1.49

④ Represents the assembly lot No.

0-9, A-Z; 0-9, A-Z mirror writing, repeated (G, I, J, O, Q, W exception)

■ Function Block Diagram

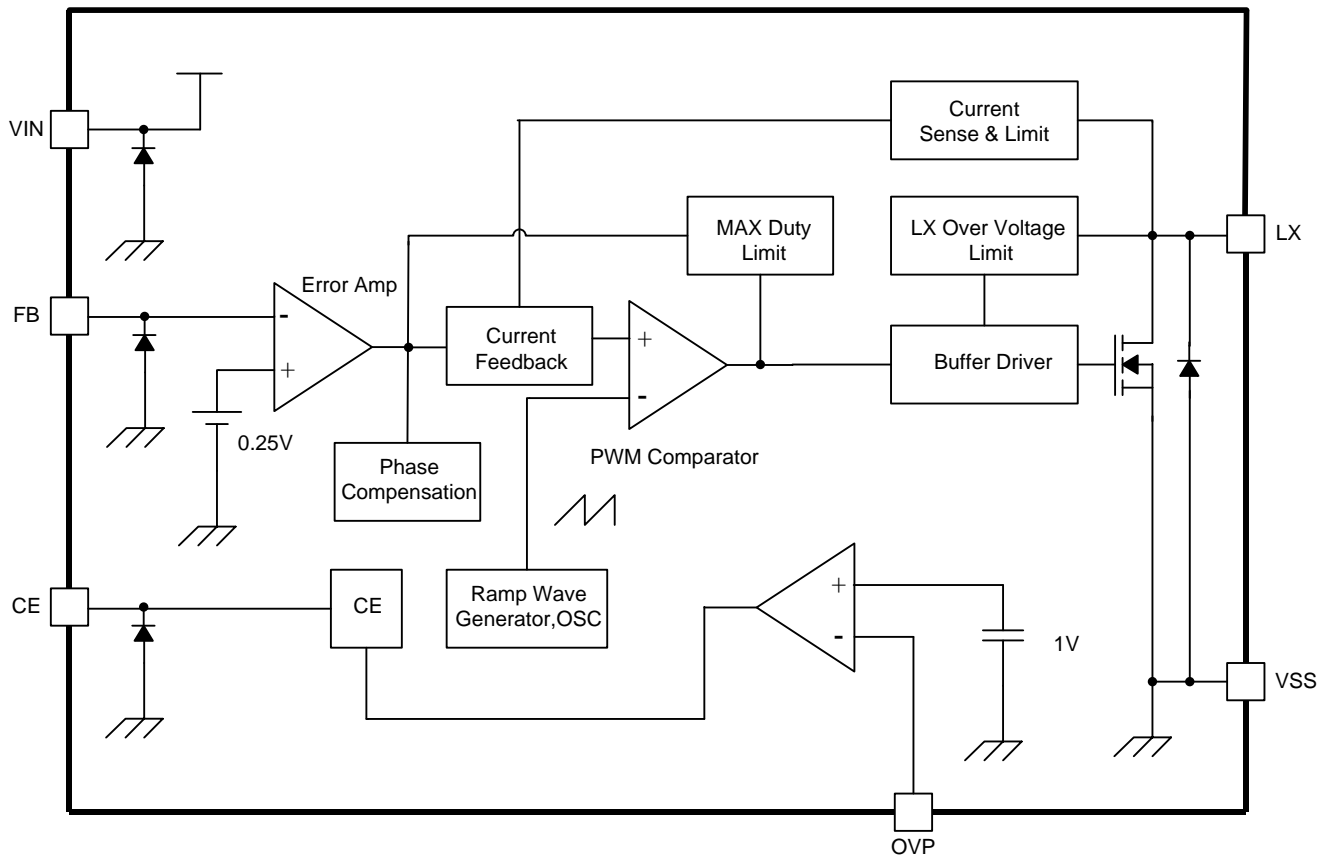

■ Absolute Maximum Ratings

Item	Symbol	Absolute maximum ratings	Unit	
VIN Pin Voltage	V_{IN}	$V_{SS}-0.3 \sim V_{SS}+7$	V	
OUT Pin Voltage	V_{OUT}	$V_{SS}-0.3 \sim V_{SS}+20$		
LX Pin Voltage	V_{LX}	$V_{SS}-0.3 \sim V_{SS}+20$		
FB Pin Voltage	V_{FB}	$V_{SS}-0.3 \sim V_{SS}+7$	V	
CE Pin Voltage	V_{CE}	$V_{SS}-0.3 \sim V_{SS}+7$	V	
OVP Pin Voltage	V_{OVP}	$V_{SS}-0.3 \sim V_{SS}+20$		
LX Pin Current	I_{LX}	1000	mA	
Power Dissipation	PD	SOT-23-6	250	mW
Operating Temperature range	T_{opr}		-40 ~ +85	°C
Storage Temperature range	T_{stg}		-55 ~ +125	

Electrical Characteristics

(Ta=25°C, unless otherwise noted)

Item	Symbol	Condition	Min.	Typ.	Max.	Unit	Circuits
FB Control Voltage (*1)	VFB	-	0.225	0.25	0.275	V	1
Output Voltage range	VOUT	-	VIN	-	20		
Lx Operating Voltage range	VLX		-	-	20		
Operating Voltage range	VIN		2.5	-	6		
Stand-by Current	ISTB	VCE=0V、VLX=5V	—		1	μA	3
Supply Current 1	IDD1			550		μA	2
Supply Current 2	IDD2	VIN=VLX、VFB=0.4V	—	65			3
Oscillation Frequency	FOSC		0.8	1.0	1.2	MHz	2
Maximum Duty Cycle	MAXDTY	VCONT=0.4V	86	92	98	%	2
Efficiency	EFFI	VIN=3.6V;RLED=20Ω	—	88	—	%	1
Current Limit	ILIM	VIN=3.6		300		mA	4
OVP Overvoltage Limit	OVPVL			20		V	2
LX On Resistance		VIN=3.6V、VLX=0.4V		2.0		Ω	2
LX Leak Current	ILXL			0	1	μA	3
CE 'H' Voltage	VCEH		0.65			V	2
CE 'L' Voltage	VCEL				0.2	V	2
CE 'H' Current	ICEH	VIN=VLX、VFB=0.4V			0.1	μA	3
CE 'L' Current	ICEL	VCE=0V、VLX=5V			-0.1	μA	3
FB 'H' Current	ICEH	VIN=VLX、VFB=0.4V			0.1	μA	3
FB 'L' Current	ICEL	VCE=0V、VLX=5V			-0.1	μA	3

(*1) Vfbt may take between 0.01V-1.49V certain value, now a major center value 0.01V, 0.2V,0.23V,0.25V

■ Test Circuits

Circuit 1

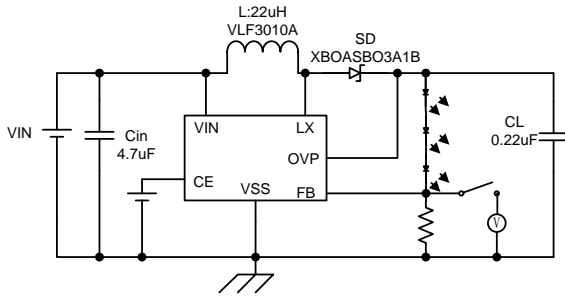

Circuit 3

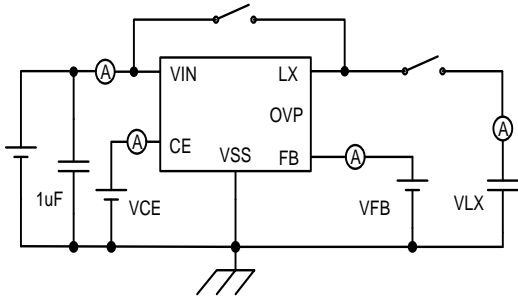

Circuit 2

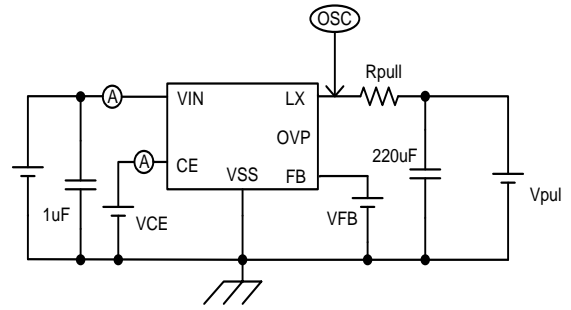

Circuit 4

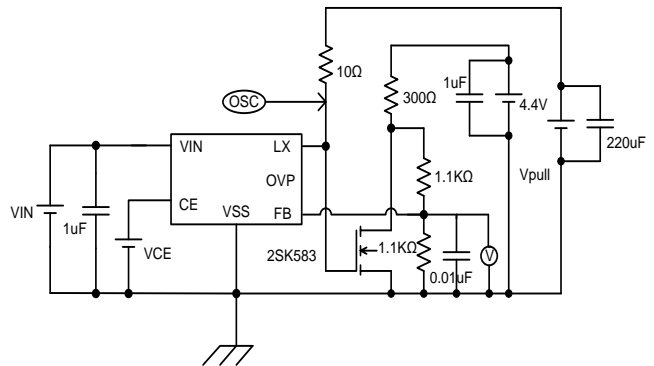

Caution The value of the resistance named RLED: $R_{LED} = V_{FB} / I_{LED}$; V_{FB} is the voltage of the FB pin; I_{LED} is the current of LED and equal to 20mA usually.

■ Typical Performance Characteristics

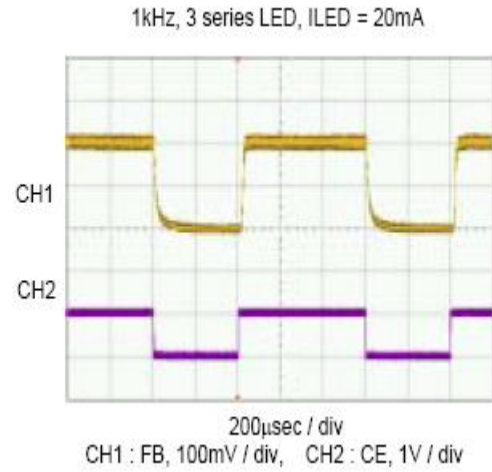
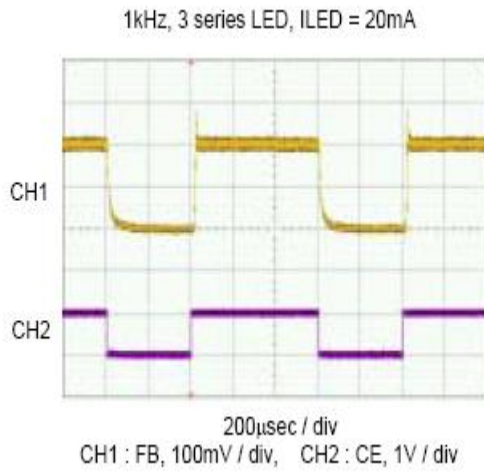
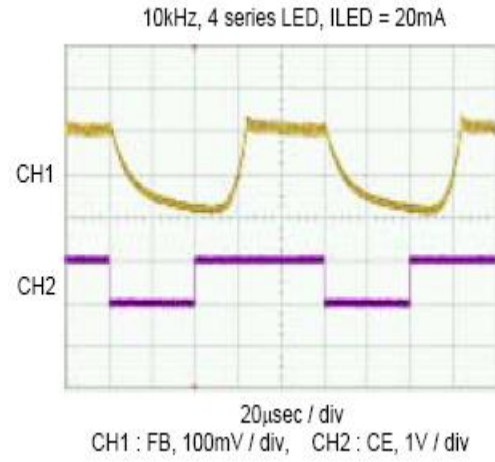
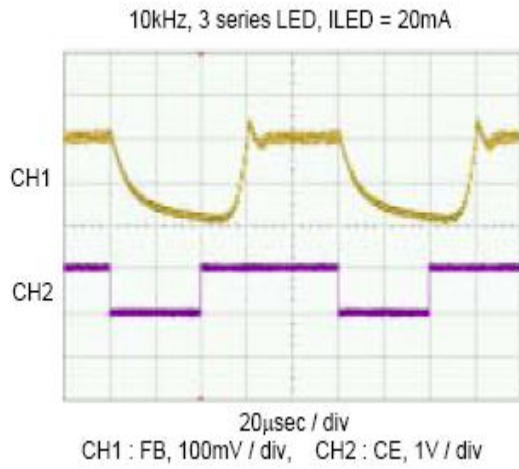

■ Package Information

- SOT-23-6L

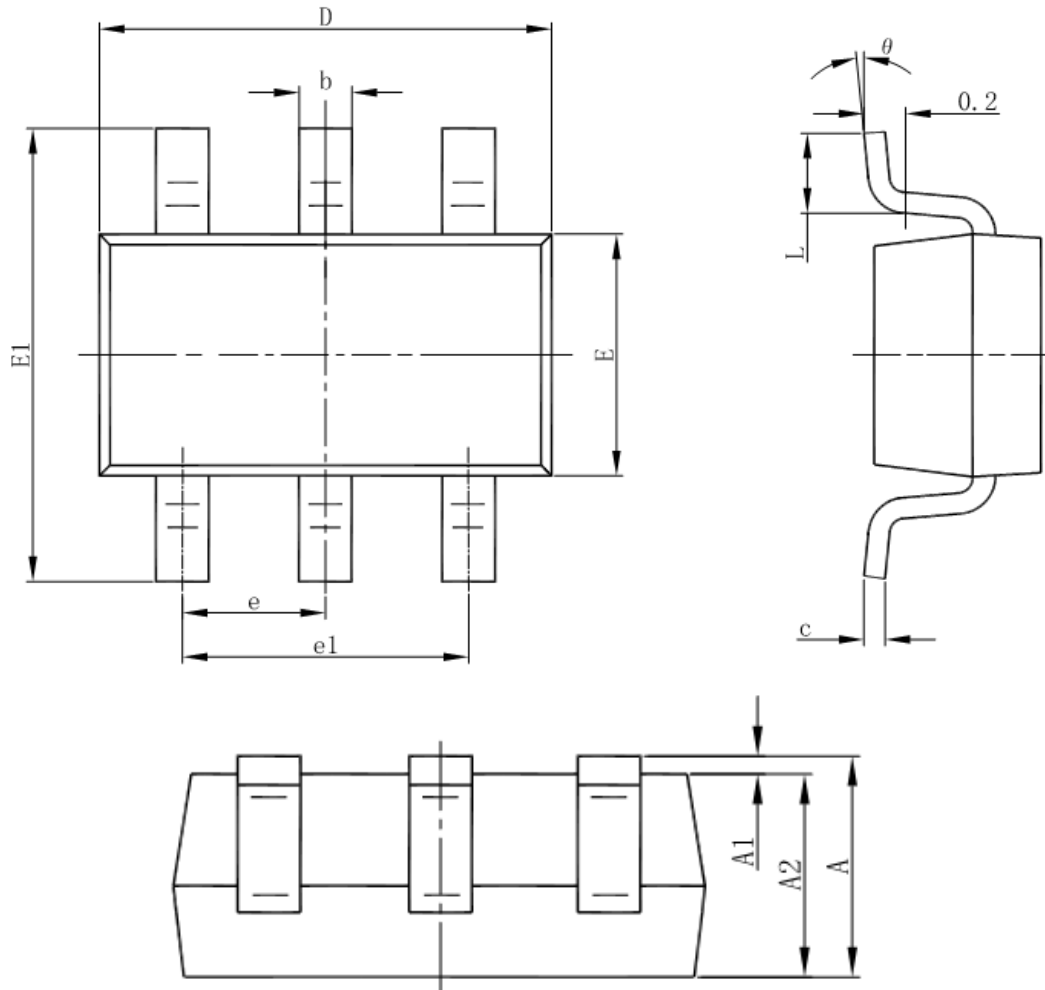

Symbol	Dimensions In Millimeters		Dimensions In Inches	
	Min	Max	Min	Max
A	1.050	1.250	0.041	0.049
A1	0.000	0.100	0.000	0.004
A2	1.050	1.150	0.041	0.045
b	0.300	0.500	0.012	0.020
c	0.100	0.200	0.004	0.008
D	2.820	3.020	0.111	0.119
E	1.500	1.700	0.059	0.067
E1	2.650	2.950	0.104	0.116
e	0.950(BSC)		0.037(BSC)	
e1	1.800	2.000	0.071	0.079
L	0.300	0.600	0.012	0.024
θ	0°	8°	0°	8°