

Step-up DC/DC Converter —Backlight Driver

General Description

The LN2118 Series is a fixed frequency, constant current step-up DC/DC converter ideal for driving LEDs used in backlighting applications on Car GPS screen and digital cameras etc. Output voltage of up to 26V can be derived, and from a 3.6V input four white Led's can be driven in series or alternatively, using a 3.6V input, a network of seven parallel legs with three in each may be driven. Luminance of the LED's is controlled by changing the duty cycle of a PWM signal applied to the CE pin.

In addition, an internal MOSFET with an RDS-on of 2Ω is used. Allow profile and small board area solution can be achieved using a chip coil and an ultra small ceramic output capacitor (CL) of 0.22μF.

Applications

- Car GPS screen

Features

- Input voltage range 2.7V—6.0V
- Output voltage range up to 26V externally set-up reference voltage 0.2V
- Oscillation frequency 1.0MHz±20%
- Efficiency 88%(When driving 3 white LEDs in series VIN=3.6V ILED=20mA)
- Control PWM control
- Stand-by Current ISTB=1.0uA(MAX)
- Load capacitor 0.22uF,ceramic

Package

- SOT-23-6L

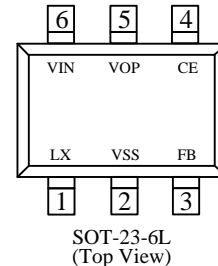

Ordering Information

LN2118 ①②③④⑤⑥

Item	Symbol	Function
①	B	Denotes Lx Overvoltage Limit: Yes Denotes Oscillation Frequency:1MHZ
②③④	010-149	Denotes FB Voltage e.g. ②=0 ③=2 ④=0 → 0.20V ②=1 ③=2 ④=3 → 1.23V
⑤	M	Denotes Package Type : SOT-23-6L
⑥	R	Embossed Tape :Standard Feed
	L	Embossed Tape :Reverse Feed

■ Typical Application Circuit

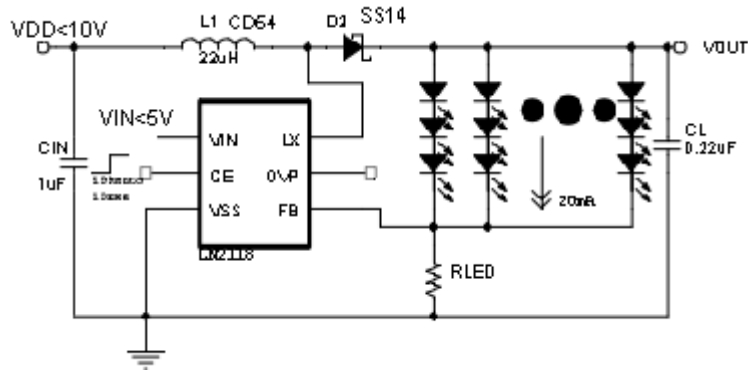
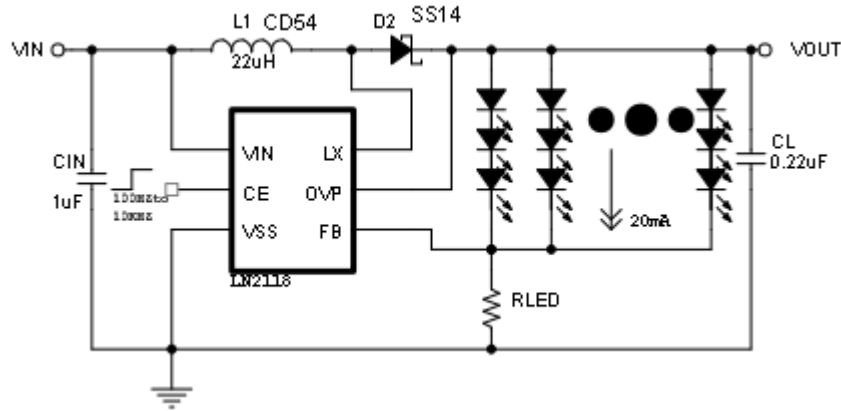

The application of double lithium-powered

Caution The value of the resistance named RLED: $RLED = VFB / (ILED * n)$; VFB is the voltage of the FB pin; ILED is the current of LED and equal to 20mA usually.

■ Functional Pin Description

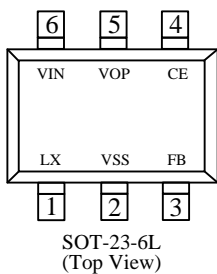

Pin Number	Pin Name	Function
1	LX	SWITCH
2	VSS	Ground
3	FB	Voltage Feedback
4	CE	Chip Enable
5	OVP	Over voltage protect
6	VIN	Power Input

■ Marking Rule

- SOT-23-6L

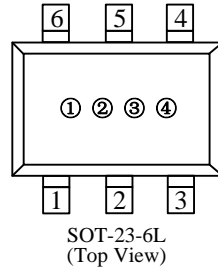

- ① Represents the product name

Symbol	Part Number
Y	LN2118****M*

- ② ③ Represents the voltage of FB pin and the type of regulator

Symbol	Vfb(V)
S1	100mV
L0	200mV
L3	230mV
L5	250mV

- ④ Represents the assembly lot No.

0-9,A-Z; 0-9,A-Z mirror writing, repeated (G, I, J, O, Q, W exception)

■ Function Block Diagram

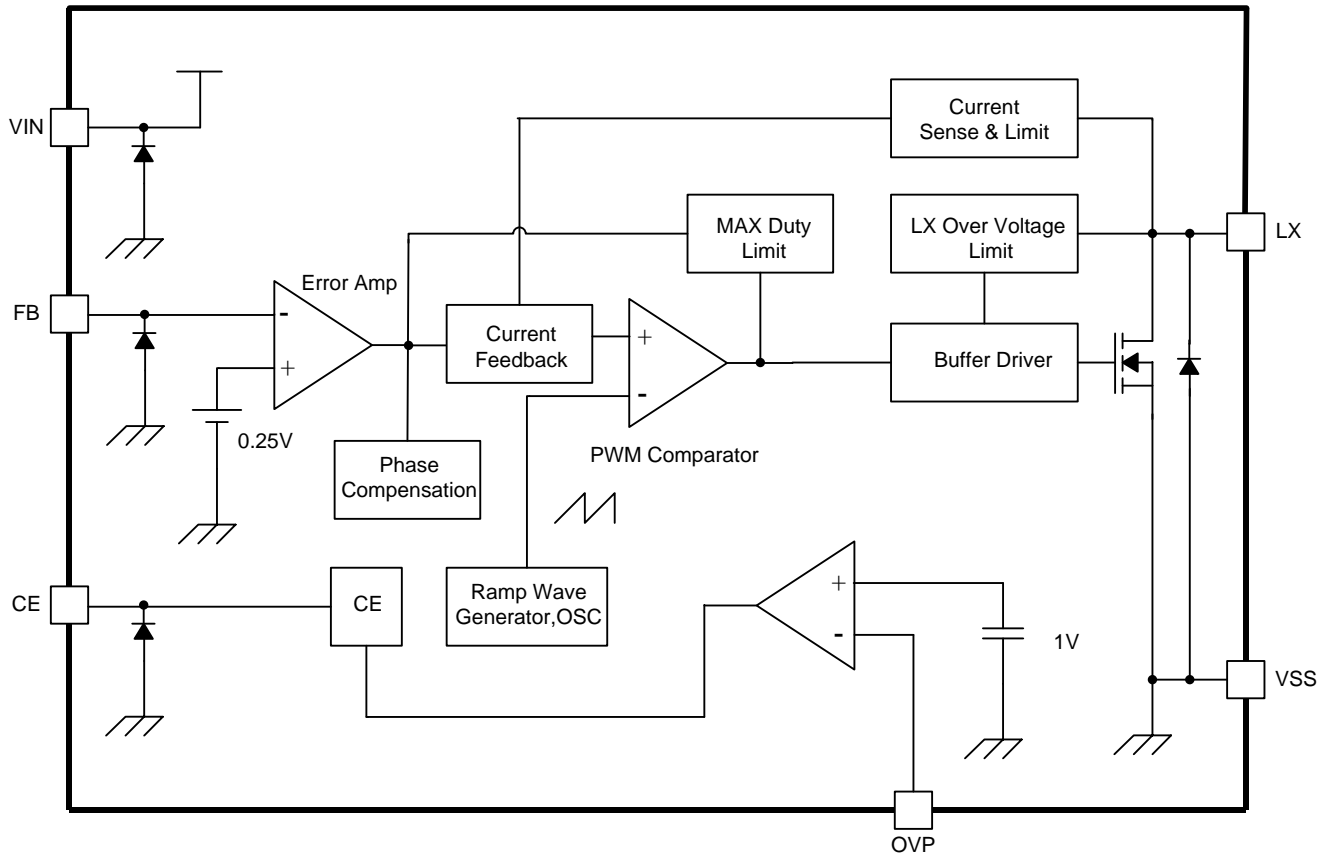

■ Absolute Maximum Ratings

Item	Symbol	Absolute maximum ratings	Unit	
VIN Pin Voltage	V_{IN}	$V_{SS}-0.3 \sim V_{SS}+7$	V	
OUT Pin Voltage	V_{OUT}	$V_{SS}-0.3 \sim V_{SS}+26$		
LX Pin Voltage	V_{LX}	$V_{SS}-0.3 \sim V_{SS}+26$		
FB Pin Voltage	V_{FB}	$V_{SS}-0.3 \sim V_{SS}+7$	V	
CE Pin Voltage	V_{CE}	$V_{SS}-0.3 \sim V_{SS}+7$	V	
OVP Pin Voltage	V_{OVP}	$V_{SS}-0.3 \sim V_{SS}+26$		
LX Pin Current	I_{LX}	1000	mA	
Power Dissipation	PD	SOT-23-6	250	mW
Operating Temperature range	T_{opr}	-40 ~ +85	°C	
Storage Temperature range	T_{stg}	-55 ~ +125		

Electrical Characteristics

(Ta=25°C, unless otherwise noted)

Item	Symbol	Condition	Min.	Typ.	Max.	Unit	Circuits
FB Control Voltage (*1)	VFB	-	0.225	0.25	0.275	V	1
Output Voltage range	VOUT	-	VIN	-	26		
Lx Operating Voltage range	VLX		-	-	26		
Operating Voltage range	VIN		2.7	-	6.0		
Stand-by Current	ISTB	VCE=0V、VLX=5V	—		1	μA	3
Supply Current 1	IDD1			550		μA	2
Supply Current 2	IDD2	VIN=VLX、VFB=0.4V	—	65			3
Oscillation Frequency	FOSC		0.8	1.0	1.2	MHz	2
Maximum Duty Cycle	MAXDTY	VCONT=0.4V	86	92	98	%	2
Efficiency	EFFI	VIN=3.6V;RLED=20Ω	—	88	—	%	1
Current Limit	ILIM	VIN=3.6		300		mA	4
OVP Overvoltage Limit	OVPOVL			26		V	2
LX On Resistance		VIN=3.6V、VLX=0.4V		2.0		Ω	2
LX Leak Current	ILXL			0	1	μA	3
CE 'H' Voltage	VCEH		1			V	2
CE 'L' Voltage	VCEL				0.6	V	2
CE 'H' Current	ICEH	VIN=VLX、VFB=0.4V			0.1	μA	3
CE 'L' Current	ICEL	VIN=VLX、VFB=0.4V			-0.1	μA	3
FB 'H' Current	ICEH	VIN=VLX、VFB=0.4V			0.1	μA	3
FB 'L' Current	ICEL	VIN=VLX、VFB=0.4V			-0.1	μA	3

(*1) Vfbt may take between 0.01V-1.49V certain value, now a major center value 0.01V, 0.2V, 0.23V, 0.25V

Test Circuits

Circuit 1

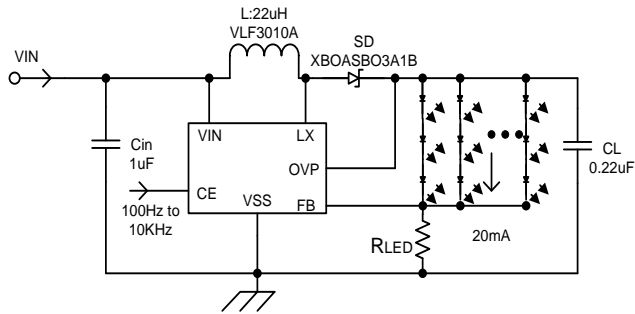

Circuit 2

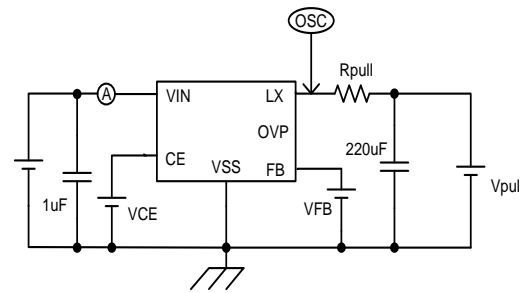

Circuit 3

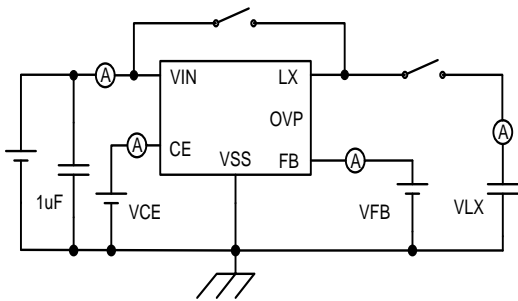

Circuit 4

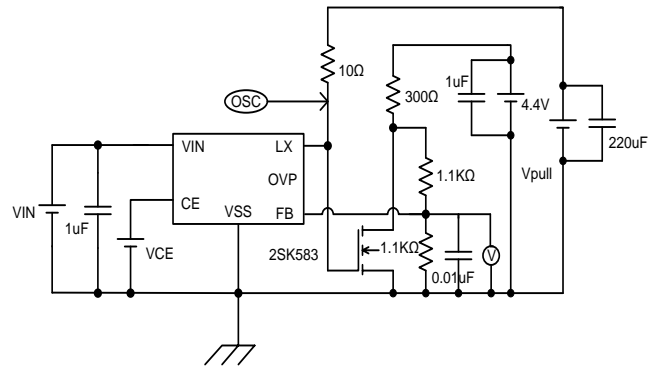

Caution The value of the resistance named RLED: $R_{LED} = V_{FB} / I_{LED}$; V_{FB} is the voltage of the FB pin; I_{LED} is the current of LED and equal to 20mA usually.

■ Typical Performance Characteristics

1kHz, 3 series LED, ILED = 20mA

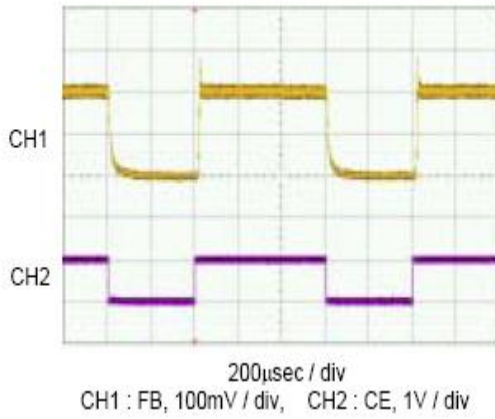

1kHz, 3 series LED, ILED = 20mA

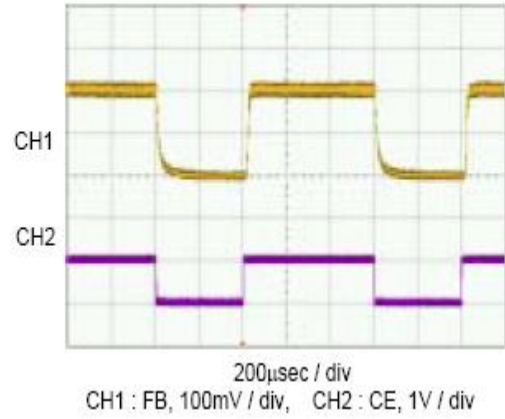

10kHz, 3 series LED, ILED = 20mA

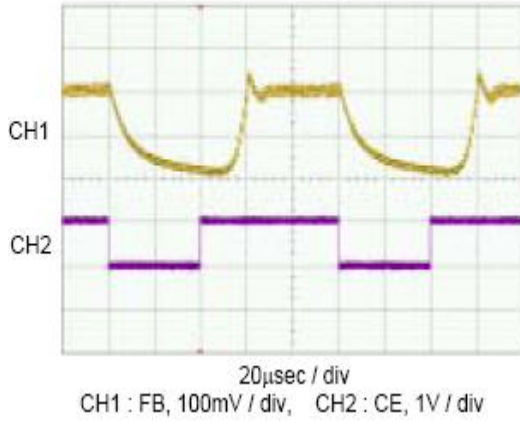

■ Package Information

- SOT-23-6L

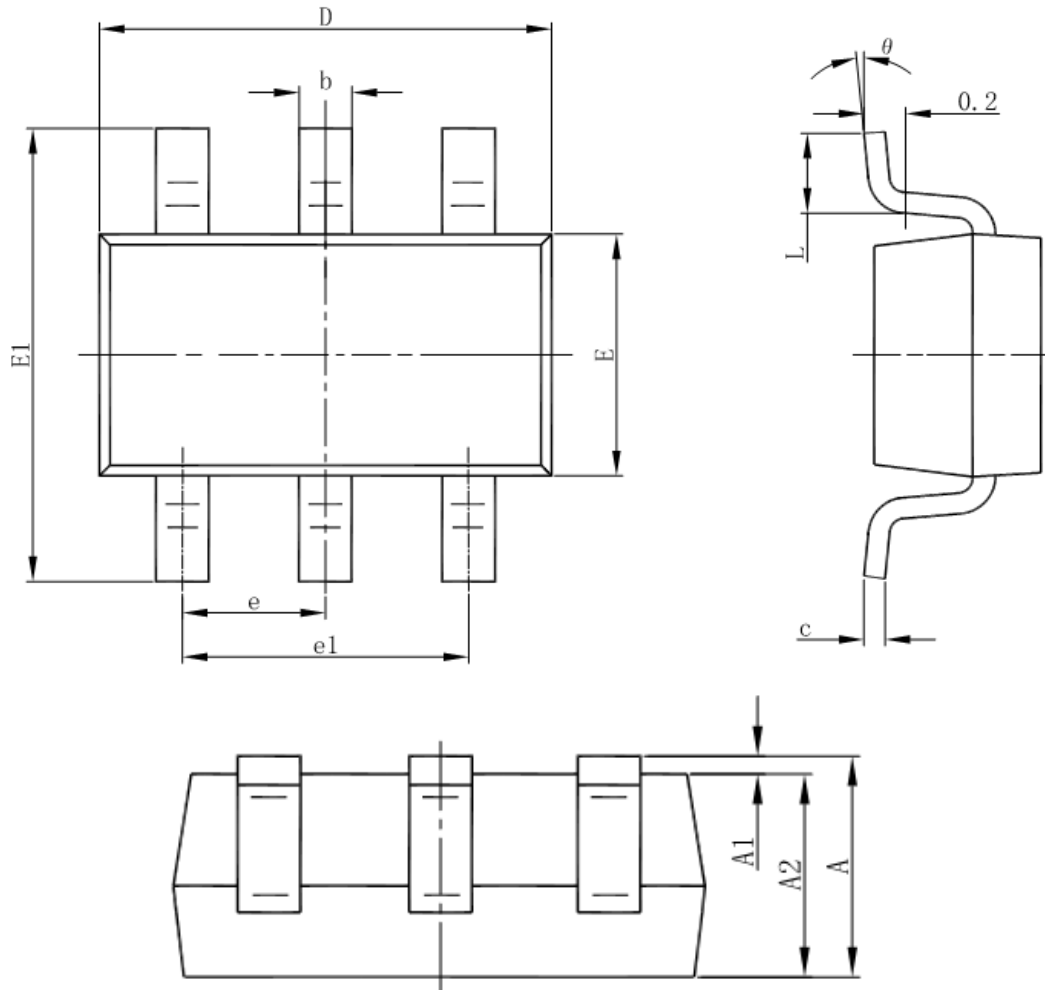

Symbol	Dimensions In Millimeters		Dimensions In Inches	
	Min	Max	Min	Max
A	1.050	1.250	0.041	0.049
A1	0.000	0.100	0.000	0.004
A2	1.050	1.150	0.041	0.045
b	0.300	0.500	0.012	0.020
c	0.100	0.200	0.004	0.008
D	2.820	3.020	0.111	0.119
E	1.500	1.700	0.059	0.067
E1	2.650	2.950	0.104	0.116
e	0.950(BSC)		0.037(BSC)	
e1	1.800	2.000	0.071	0.079
L	0.300	0.600	0.012	0.024
θ	0°	8°	0°	8°