

PWM Control Step-up DC/DC Converter

General Description

The LN2119 Series is a fixed frequency, constant current step-up DC/DC converter ideal for driving OLED. Output voltage of up to 22V can be derived, and from a li-ion battery supply ,the output voltage can be 12V drive OLED. A 2 ohm resistance of NMOS is integrated in the circuit , withstand voltage can support 22V, with a small SOT-23-5 package saves PCB space and BOM cost.

Applications

- Mobil phones, PHS
- PDAs
- Digital still cameras

Typical Application Circuit

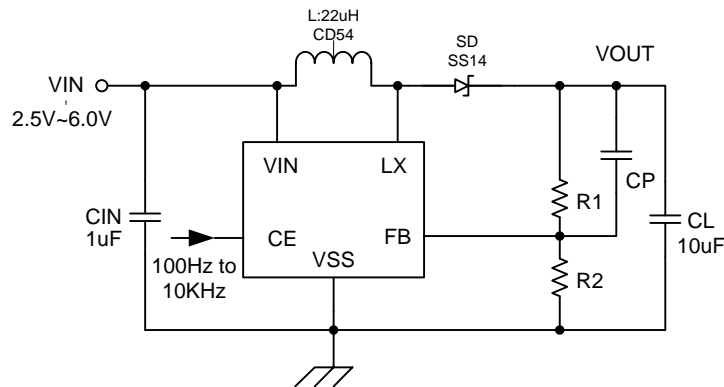

$$\frac{V_{OUT}}{V_{FB}} = \frac{R1+R2}{R2}$$

Note: R1 and R2 can be adjusted by the voltage of VOUT and FB Pin; (when vout is equal to 12V, recommended resistor R1 = 875K, R2 = 100K, CP=100pF)

Ordering Information

LN2119 ①②③

Item	Symbol	Function
①	B	Denotes Oscillation Frequency:1.0MHZ
②	M	Denotes Package Type : SOT-23-5L
③	R	Embossed Tape :Standard Feed
	L	Embossed Tape :Reverse Feed

Pin Configuration

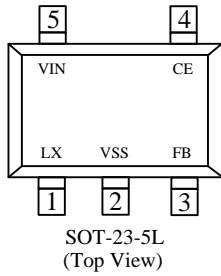

Pin Number	Pin Name	Function
1	LX	Switch
2	VSS	Ground
3	FB	Voltage Feedback
4	CE	Chip Enable
5	VIN	Power Input

Function Block Diagram

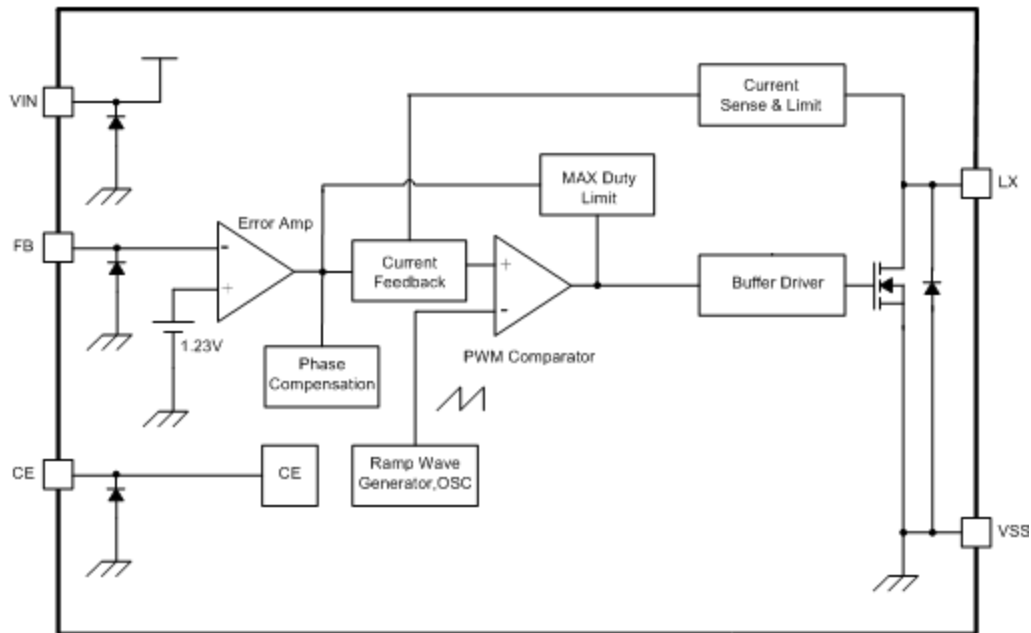

Absolute Maximum Ratings

Item	Symbol	Absolute maximum ratings	Unit	
VIN Pin Voltage	VIN	$V_{SS}-0.3 \sim V_{SS}+7$	V	
LX Pin Voltage	VLX	$V_{SS}-0.3 \sim V_{SS}+22$		
FB Pin Voltage	V_{FB}	$V_{SS}-0.3 \sim V_{SS}+7$	V	
CE Pin Voltage	V_{CE}	$V_{SS}-0.3 \sim V_{SS}+7$	V	
LX Pin Current	I_{LX}	600	mA	
Power Dissipation	PD	SOT-23-5	250	mW
Operating Temperature range	T_{opr}		$-40 \sim +85$	°C
Storage Temperature range	T_{stg}		$-55 \sim +125$	

■ Marking Rule

- SOT-23-5L

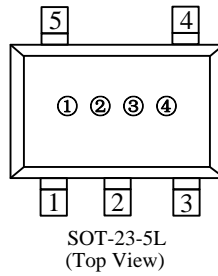

- ① Represents the product name

Symbol	Part Number
Z	LN2119****M*

- ② Represents the voltage of FB pin

Symbol	The output voltage of FB pin (V)
C	1.23

- ③ Represents the package type

Symbol	Package Type
3	SOT-23-5

- ④ Represents the assembly lot No.

0-9, A-Z; 0-9, A-Z mirror writing, repeated (G, I, J, O, Q, W exception)

Electrical Characteristics

(Ta=25°C, unless otherwise noted)

Item	Symbol	Condition	Min.	Typ.	Max.	Unit	Circuits
FB Control Voltage	VFB	-	1.205	1.23	1.255	V	1
Output Voltage range	VOUT	-	VIN	-	22		
Lx Operating Voltage range	VLX		-	-	22		
Operating Voltage range	VIN		2.5	-	6		
Stand-by Current	ISTB	VCE=0V、VLX=5V	—		1	uA	3
Supply Current 1	IDD1		500	1200	1500	uA	2
Supply Current 2	IDD2	VIN=VLX、VFB=2V	—	90			3
Oscillation Frequency	FOSC		0.8	1.0	1.2	MHz	2
Maximum Duty Cycle	MAXDTY	VCONT=0.4V		75		%	2
Efficiency	EFFI	VIN=3.6V;RLED=20Ω	—	88	—	%	1
Current Limit	ILIM	VIN=3.6		600		mA	4
LX On Resistance		VIN=3.6V、VLX=0.4V		2.0		Ω	2
LX Leak Current	ILXL			0	1	uA	3
CE 'H' Voltage	VCEH		1.1			V	2
CE 'L' Voltage	VCEL				0.6	V	2
CE 'H' Current	ICEH	VIN=VLX、VFB=0.4V			0.1	uA	3
CE 'L' Current	ICEL	VCE=0V、VLX=5V			-0.1	uA	3
FB 'H' Current	ICEH	VIN=VLX、VFB=0.4V			0.1	uA	3
FB 'L' Current	ICEL	VCE=0V、VLX=5V			-0.1	uA	3

Test Circuits

Circuit 1

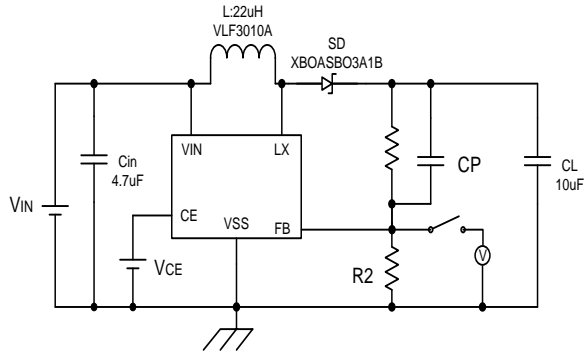

Circuit 2

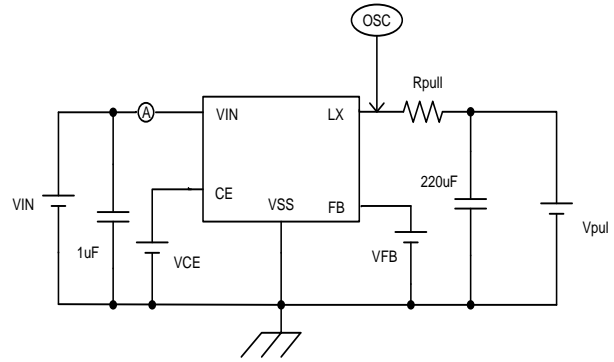

Circuit 3

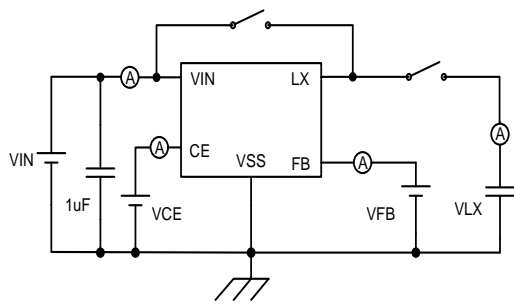

Circuit 4

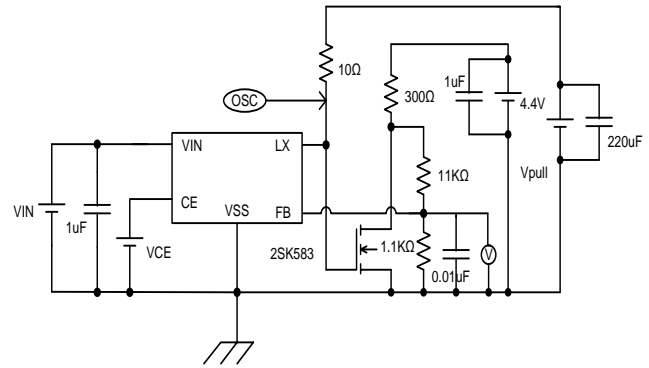

Typical Performance Characteristics

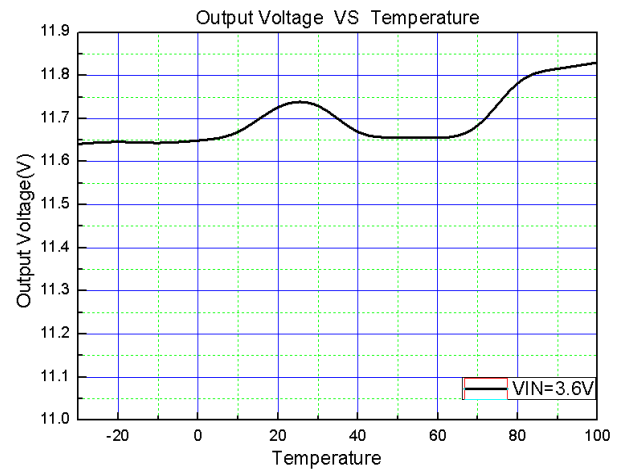
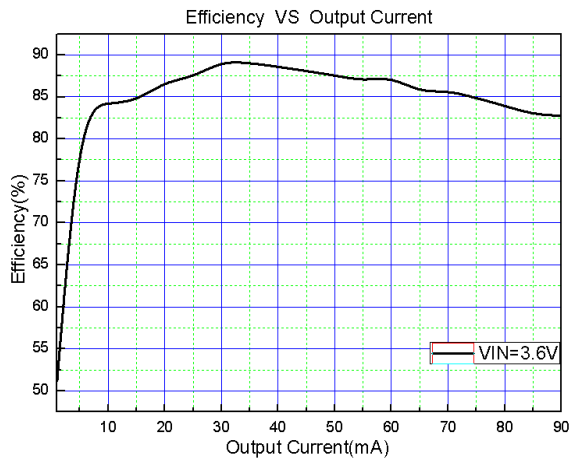

Package Information

- SOT-23-5L

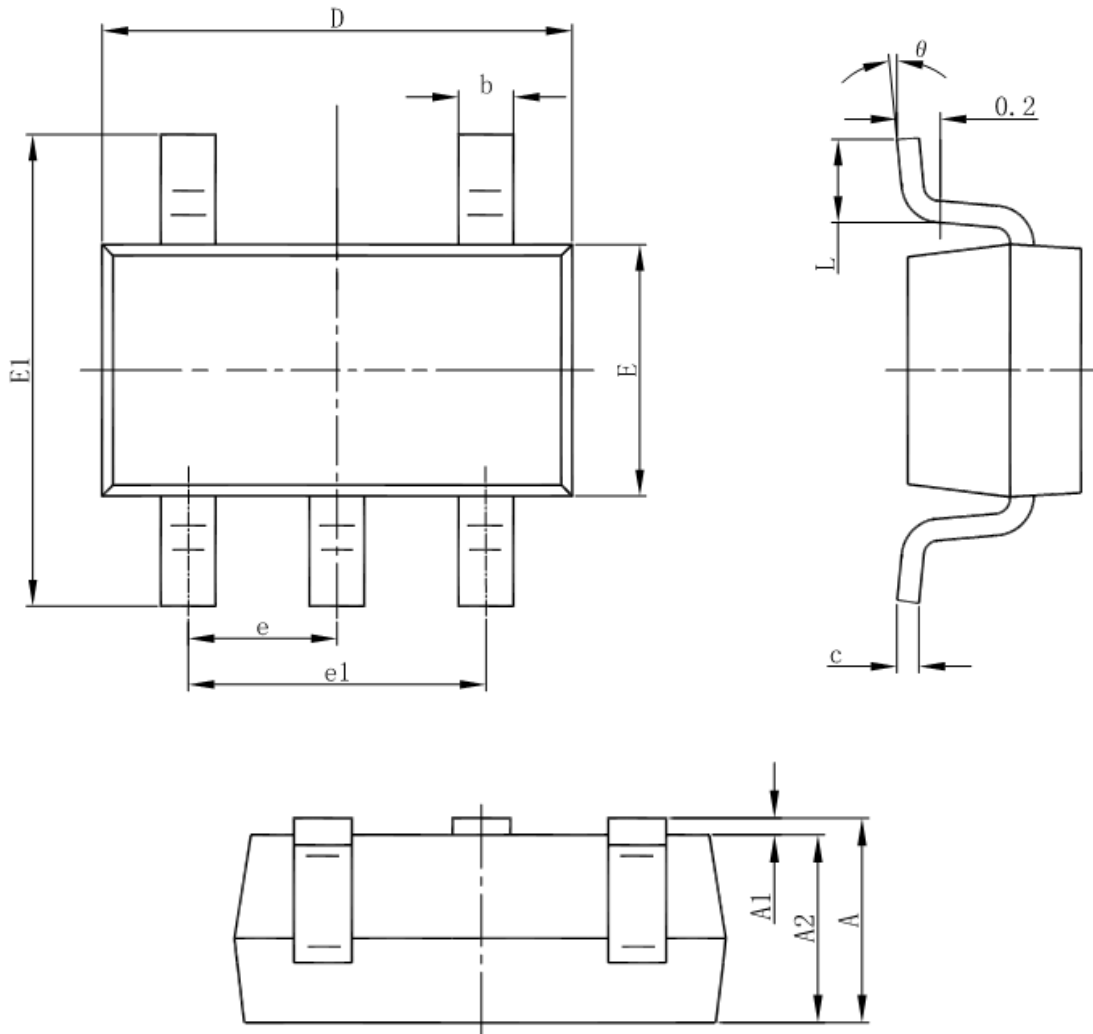

Symbol	Dimensions In Millimeters		Dimensions In Inches	
	Min	Max	Min	Max
A	1.050	1.250	0.041	0.049
A1	0.000	0.100	0.000	0.004
A2	1.050	1.150	0.041	0.045
b	0.300	0.500	0.012	0.020
c	0.100	0.200	0.004	0.008
D	2.820	3.020	0.111	0.119
E	1.500	1.700	0.059	0.067
E1	2.650	2.950	0.104	0.116
e	0.950(BSC)		0.037(BSC)	
e1	1.800	2.000	0.071	0.079
L	0.300	0.600	0.012	0.024
θ	0°	8°	0°	8°