

## 600mA, 1.3MHz Micropower Synchronous Boost Converter

### General Description

The LN2240 is a synchronous, fixed frequency, step-up DC/DC converters delivering high efficiency in a 6-lead ThinSOT package. Capable of supplying 5V at 600mA from a Lithium Battery input, the devices contain an internal NMOS switch and PMOS synchronous rectifier.

A switching frequency of 1.3MHz minimizes solution footprint by allowing the use of tiny, low profile inductors and ceramic capacitors. The current mode PWM design is internally compensated, reducing external parts count. The LN2240 features automatic shifting to power saving PFM Mode operation at light loads. Antiringing control circuitry reduces EMI concerns by damping the inductor in discontinuous mode, and the devices feature low shutdown current of under 1 $\mu$ A.

Both devices are available in the low profile (1mm) SOT-23 package.

### Features

- Up to 93% Efficiency
- 1.3MHz Fixed Frequency Switching
- Internal Synchronous Rectifier
- 2.5V to 5V Output Range
- Automatic PFM/PWM Mode Operation
- Logic Controlled Shutdown (<1 $\mu$ A)
- Antiringing Control Minimizes EMI
- Tiny External Components
- Low Profile (1mm) SOT-23 Package

### Applications

- MP3/4 PMP
- Digital Camera
- LCD Bias Voltage
- Handheld Instruments
- Wireless Handsets
- GPS Receivers

### Package

- SOT-23-6

### Typical Application Circuit

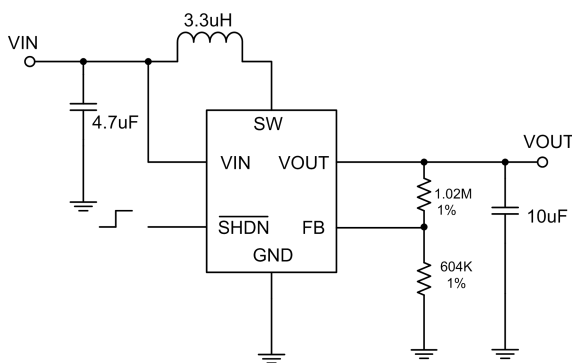

Figure1.Vout=3.3V

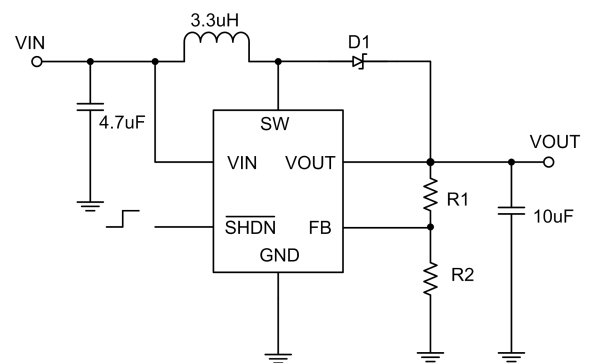

Figure 2.Vout>4.5V

## Ordering Information

### LN2240 ①②③④

| Designator | Symbol   | Description  |
|------------|----------|--|
| ①②         | 25-50/AD | Output Voltage: e.g. 33= 3.3V etc.<br>Adjustable version: ①② fixed as AD |
| ③          | M        | Package Types: SOT-23-6  |
| ④          | R        | Embossed Tape : Standard Feed  |
|            | S        | Embossed Tape : Reverse Feed   |

## Functional Pin Description

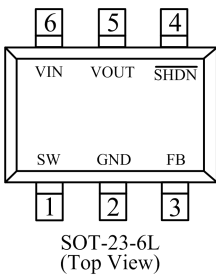

| Pin | Name | Function  |
|-----|------|---|
| 1   | SW   | Switch Pin.   |
| 2   | GND  | Ground Pin.   |
| 3   | FB   | Feedback Pin.   |
| 4   | SHDN | Chip Enable pin. Active high. Internal pull high for auto start up. |
| 5   | VOUT | Output Pin.   |
| 6   | VIN  | Startup input Pin.  |

## Marking Rule

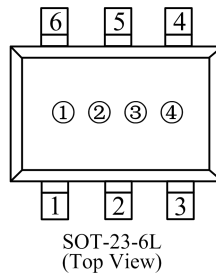

### ① Represents the product name

| Symbol | Product Name |
|--------|--------------|
| 4      | LN2240◆◆◆◆   |

### ② Represents the output voltage type

| Symbol | Represents                   |
|--------|------------------------------|
| A      | Output voltage is adjustable |
| F      | Output voltage is fixed      |

### ③ Represents the package type

| Symbol | Represents |
|--------|------------|
| M      | SOT-23-6   |

### ④ Represents the assembly lot No.

0-9, A-Z; 0-9, A-Z mirror writing, repeated (G, I, J, O, Q, W exception)

## Function Block Diagram

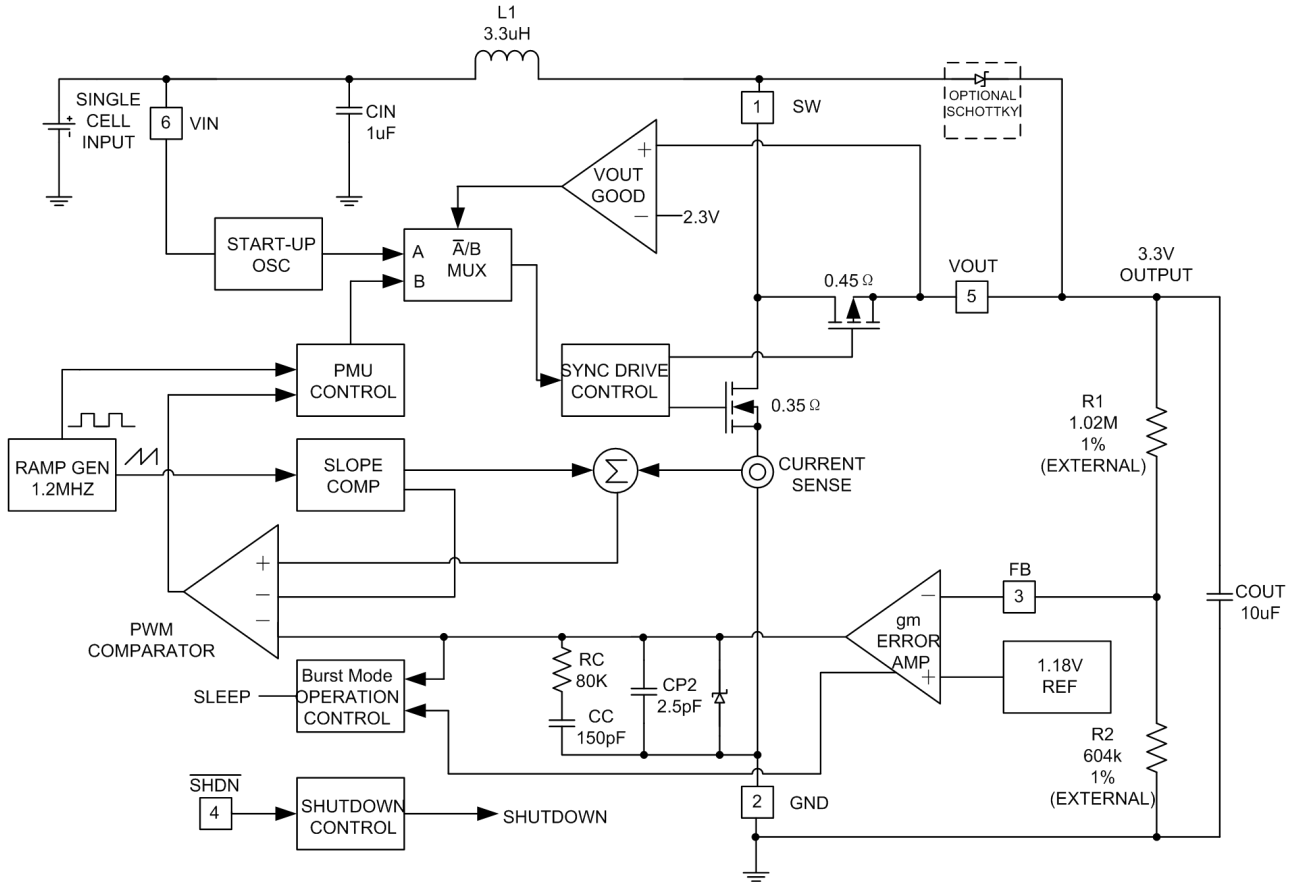

## Absolute Maximum Ratings

| Parameter                        | Symbol             | Maximum Rating               | Unit |    |
|----------------------------------|--------------------|------------------------------|------|----|
| Input Voltage                    | $V_{IN}$           | $V_{SS}-0.3 \sim V_{SS}+6$   | V    |    |
|                                  | $V_{sw}$           | $V_{SS}-0.3 \sim V_{IN}+0.6$ |      |    |
|                                  | $V_{SHDN,FB,VOUT}$ | $V_{SS}-0.3 \sim V_{IN}+0.3$ |      |    |
| Power Dissipation                | $P_D$              | SOT-23-6                     | 300  | mW |
| Operating Ambient Temperature    | $T_{opr}$          | -40~+85                      |      | °C |
| Storage Temperature              | $T_{stg}$          | -40~+125                     |      |    |
| Reflow Temperature(soldeing,10s) | $T_{refl}$         | 250                          |      | °C |

## ■ Electrical Characteristics

( $V_{in}=2.5V, V_{out}=3.3V, T_A=25^{\circ}C$ , unless otherwise specified)

| Parameter                    | Conditions                                      | Min  | Typ  | Max  | Units    |
|------------------------------|---|------|------|------|----------|
| Minimum Start-Up Voltage     | $I_{LOAD} = 1mA$                                |      | 1.5  |      | V        |
| Output Voltage Adjust Range  |   | 2.5  |      | 5    | V        |
| Feedback Voltage             |   | 1.16 | 1.18 | 1.20 | V        |
| Feedback Input Current       | $V_{FB} = 1.18V$                                |      | 1    |      | nA       |
| Quiescent Current (Shutdown) | $V_{/SHDN} = 0V$ , Not Including Switch Leakage |      | 0.01 | 1    | $\mu A$  |
| Quiescent Current (Active)   | Measured On VOUT                                |      | 300  | 400  | $\mu A$  |
| NMOS Switch Leakage          | $V_{SW} = 5V$                                   |      | 0.1  | 5    | $\mu A$  |
| PMOS Switch Leakage          | $V_{SW} = 0V$                                   |      | 0.1  | 5    | $\mu A$  |
| NMOS Switch On Resistance    | $V_{OUT} = 3.3V$                                |      | 0.35 |      | $\Omega$ |
|                              | $V_{OUT} = 5.0V$                                |      | 0.2  |      | $\Omega$ |
| PMOS Switch On Resistance    | $V_{OUT} = 3.3V$                                |      | 0.45 |      | $\Omega$ |
|                              | $V_{OUT} = 5.0V$                                |      | 0.3  |      | $\Omega$ |
| NMOS Current Limit           |   | 1.5  | 2.0  |      | A        |
| Max Duty Cycle               |   | 75   | -    | 85   | %        |
| Switching Frequency          |   | 1.1  | 1.3  | 1.5  | MHz      |
| /SHDN input high             |   | 0.65 |      |      | V        |
| /SHDN input low              |   |      |      | 0.5  | V        |
| /SHDN input current          | $V_{/SHDN} = 5.5V$                              |      | 0.1  | 1    | $\mu A$  |

## Typical Performance Characteristics

### ● Vout Vs Temperature

(Vin=SHDN=2.5V,Iload=30mA)

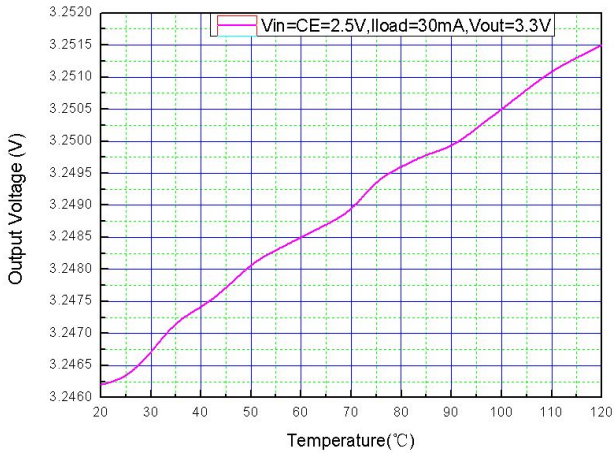

### ● Oscillation Frequency VS Temperature

(Vin=SHDN=2.5V,Iload=300mA)

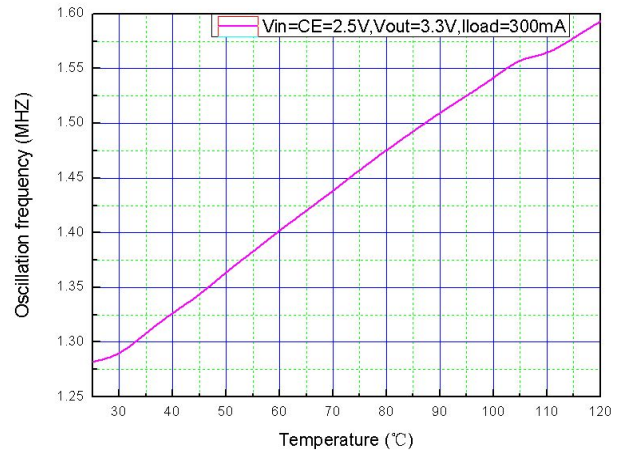

### ● Load Transient Response

(Vin=SHDN=2.5V,Vout=3.3V,Iload=0~400mA)

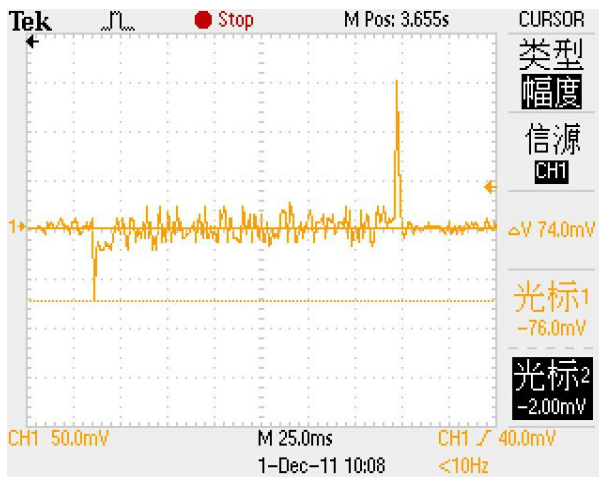

### ● Wave form in PWM Mode

(Vin=2.5V,Vout=3.3V,Iload=400mA)

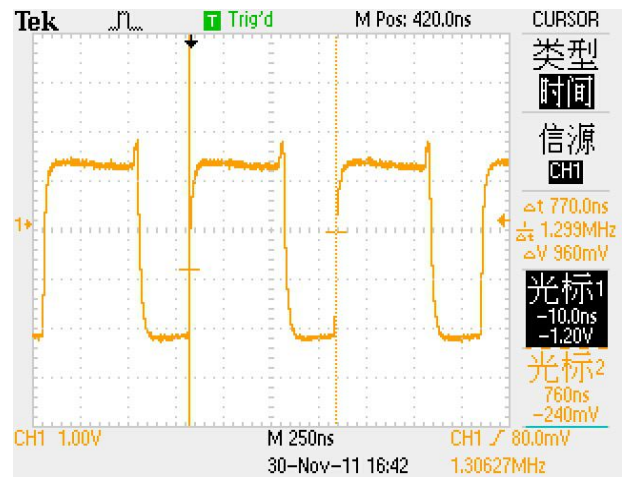

### ● Efficiency VS Output Current

Efficiency VS Output Current

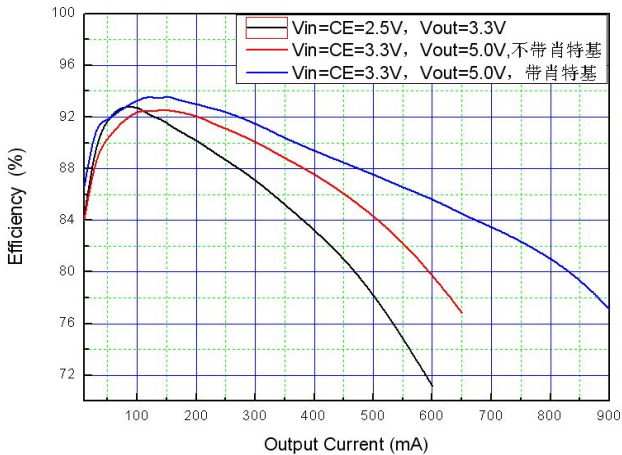

## ■ Operation

The LN2240 are 1.3MHz, synchronous boost converters housed in a 6-lead Thin SOT package. The devices feature fixed frequency, current mode PWM control for exceptional line and load regulation. With its low  $R_{DS(ON)}$  and gate charge internal MOSFET switches, the devices maintain high efficiency over a wide range of load current. Detailed descriptions of the three distinct operating modes follow. Operation can be best understood by referring to the Block Diagram.

- **Device Enable**

The device starts to work when  $\overline{SHUTDOWN}$  is higher than 0.65V. And it shuts down when  $\overline{SHUTDOWN}$  is lower than 0.5V. In shutdown mode, the regulator stops switching, all internal control circuit is off and the load is disconnected from the input.

- **Error Amp**

The error amplifier is an internally compensated transconductance type amplifier. The internal 1.18V reference voltage is compared with the voltage at the FB pin to generate an error signal at the output of the error amplifier.

- **Current Sensing**

A signal representing NMOS switch current is summed with the slope compensator. The summed signal is compared to the error amplifier output to provide a peak current control command for the PWM. Peak switch current is limited to approximately 2.0 A independent of input or output voltage.

- **Zero Current Comparator**

The zero current comparator monitors the inductor current to the output and shuts off the synchronous rectifier once this current reduces to approximately 20mA. This prevents the inductor current from reversing in polarity improving efficiency at light loads.

## Application Information

### Setting the Output Voltage

The external voltage divider from Vout to GND programs the output voltage via FB from 2.5V to 5V according to the formula:

$$V_{out} = 1.18V \times \left(1 + \frac{R1}{R2}\right)$$

### Setting the Inductor

The inductor with 1.6A current rating and low DC resistance is recommended. The inductance value can be calculated from the following formula:

$$L = \frac{V_{in} \times (V_{out} - V_{in})}{V_{out} \times \Delta I_L \times f_s}$$

Where  $\Delta I_L$  is the inductor current ripple. It is recommended the inductor current ripple to be around 30%~50% of the input current.

### Setting the Input Capacitor

The input capacitor (C1) is required to maintain the DC input voltage. Ceramic capacitors with low ESR/ESL types are recommended. The input voltage ripple can be estimated by:

$$\Delta V_{in} = \frac{V_{in}}{8 \times f_s^2 \times L \times C1} \times \left(1 - \frac{V_{in}}{V_{out}}\right)$$

Typically, a 4.7 $\mu$ F X7R ceramic capacitor is recommended.

### Setting the Output Capacitor

The output current to the step-up converter is discontinuous, therefore a capacitor is essential to supply the AC current to the load. Use low ESR capacitors for the best performance. Ceramic capacitors with X7R dielectrics are highly recommended because of their low ESR and small temperature coefficient. The output voltage ripple can be estimated by:

$$\Delta V_{out} = \frac{V_{out}}{C2 \times f_s \times R_L} \times \left(1 - \frac{V_{in}}{V_{out}}\right) \quad \text{Typically, a } 10\mu\text{F X7R ceramic capacitor is recommended.}$$

### RC Snubber Circuit

For applications with input voltages above 4.5V which could exhibit an overload or short-circuit condition, a RC Snubber circuit is required between the SW pin and GND. The recommended parameters are  $R3=2\Omega$ ,  $C5=1\text{nF}$ . The circuit can be seen in Figure 3.

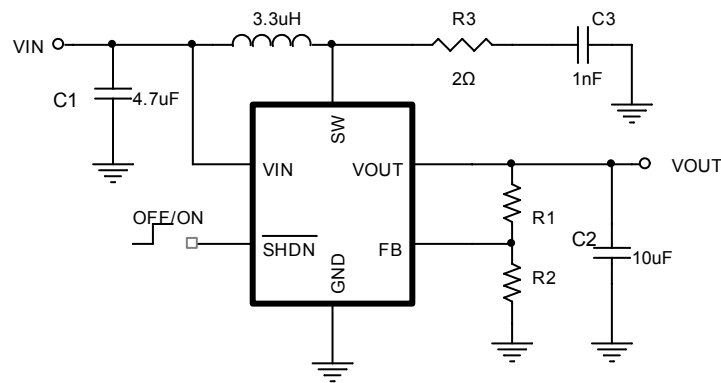
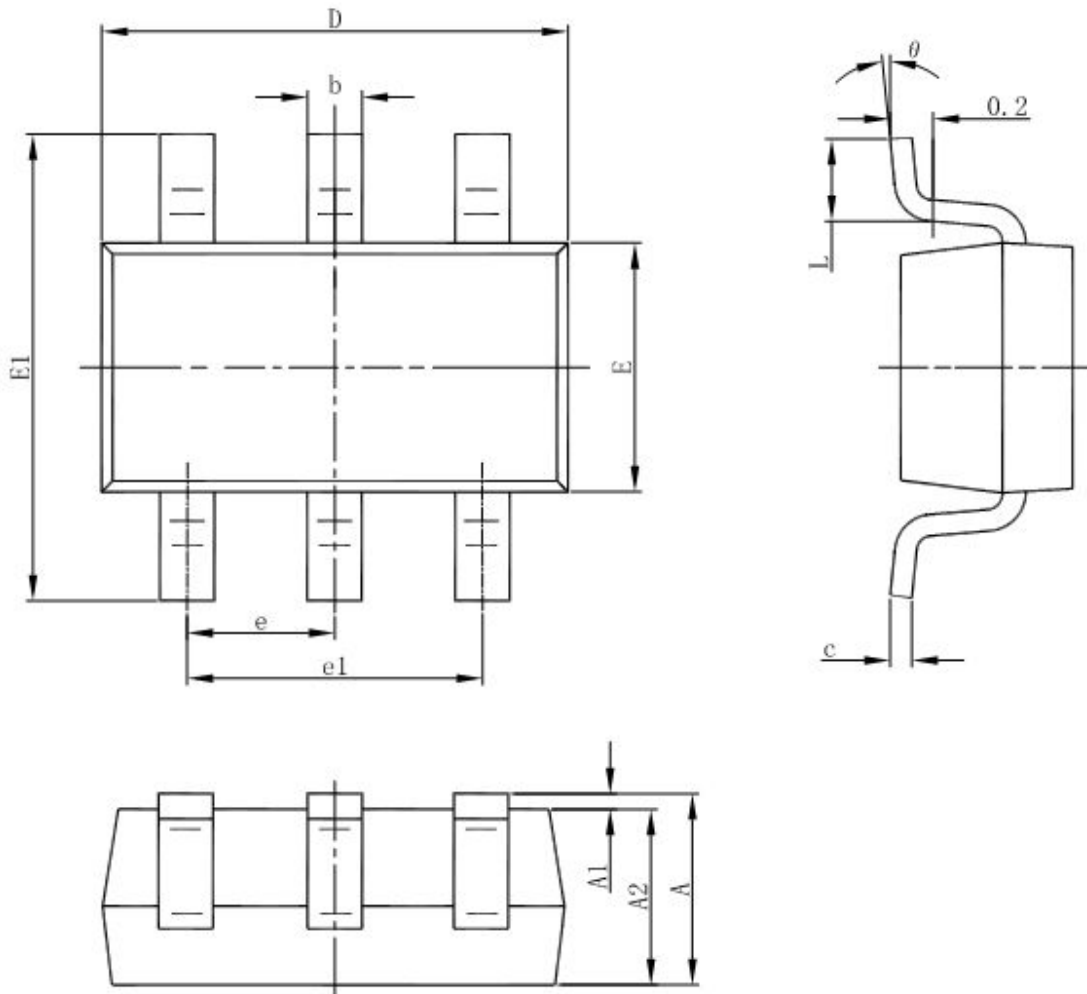

Figure 3. Vin>4.5V

■ Package Information

- SOT-23-6



| Symbol   | Dimensions In Millimeters |       | Dimensions In Inches |       |
|----------|---------------------------|-------|----------------------|-------|
|          | Min                       | Max   | Min                  | Max   |
| A        | 1.050                     | 1.250 | 0.041                | 0.049 |
| A1       | 0.000                     | 0.100 | 0.000                | 0.004 |
| A2       | 1.050                     | 1.150 | 0.041                | 0.045 |
| b        | 0.300                     | 0.500 | 0.012                | 0.020 |
| c        | 0.100                     | 0.200 | 0.004                | 0.008 |
| D        | 2.820                     | 3.020 | 0.111                | 0.119 |
| E        | 1.500                     | 1.700 | 0.059                | 0.067 |
| E1       | 2.650                     | 2.950 | 0.104                | 0.116 |
| e        | 0.950(BSC)                |       | 0.037(BSC)           |       |
| e1       | 1.800                     | 2.000 | 0.071                | 0.079 |
| L        | 0.300                     | 0.600 | 0.012                | 0.024 |
| $\theta$ | 0°                        | 8°    | 0°                   | 8°    |