

N-Channel Enhancement Mode Field Effect Transistor

General Description

Product Summary		
V_{DSS}	I_D	$R_{DS(ON)}(m\Omega)TYP$
20V	0.65A	260 @ $V_{GS}= 4.5V$
	0.55A	320 @ $V_{GS}= 2.5V$

Features

- Super high dense cell design for low $R_{DS(ON)}$
- Rugged and reliable
- Simple drive requirement
- SOT-323 package

Package

- SOT-323

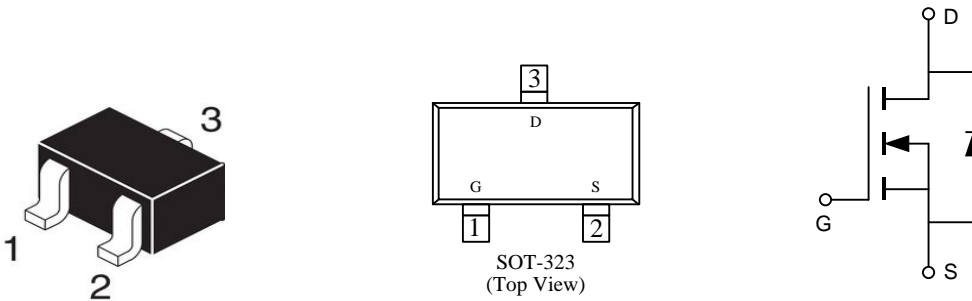

Ordering Information

Part Number	Storage Temperature	Package	Devices Per Reel
LN2308C	-55°C to +150°C	SOT-323	3000

Absolute Maximum Ratings

($T_A=25^\circ\text{C}$ unless otherwise noted)

parameter	symbol	limit	unit
Drain-source voltage	V_{DSS}	20	V
Gate-source voltage	V_{GSS}	± 12	V
Coutinuous drain current ($T_j=150^\circ\text{C}$)	I_D	$T_A=25^\circ\text{C}$	0.65
		$T_A=80^\circ\text{C}$	0.45
Pulsed drain current	I_{DM}	2.5	A
Drain-source Diode forward current	I_S	0.3	A
Power dissipation	P_D	$T_A=25^\circ\text{C}$	0.27
		$T_A=70^\circ\text{C}$	0.16
Operating junction Temperature range	T_j	-55—150	$^\circ\text{C}$

Electrical Characteristics

(TA=25°C unless otherwise noted)

Parameter	Symbol	Condition	Min	Typ	Max	Unit
Static						
Drain-source breakdown voltage	$V_{(BR)DSS}$	$V_{GS}=0V, I_D=250\mu A$	20			V
Gate threshold voltage	$V_{GS(th)}$	$V_{DS}=V_{GS}, I_D=250\mu A$	0.35		1.0	V
Gate leakage current	I_{GSS}	$V_{DS}=0V, V_{GS}=\pm 12V$			100	nA
Zero gate voltage drain current	I_{DSS}	$V_{DS}=20V, V_{GS}=0V$			1	μA
		$V_{DS}=20V, V_{GS}=0V$ $T_J=55^\circ C$			5	
On-state drain current	$I_{D(ON)}$	$V_{DS} \geq 4.5V, V_{GS}=5V$	0.7			A
Drain-source on-state resistance	$R_{DS(ON)}$	$V_{GS}=4.5V, I_D=0.65A$		0.15	0.25	Ω
		$V_{GS}=2.5V, I_D=0.55A$		0.19	0.30	
		$V_{GS}=1.8V, I_D=0.45A$		0.42	0.80	
Forward transconductance	gfs	$V_{DS}=10V, I_D=0.4A$		1.0		S
Diode forward voltage	V_{SD}	$I_S=0.15A, V_{GS}=0V$		0.8	1.2	V
Dynamic						
Total gate charge	Q_g	$V_{DS}=10V$ $I_D=0.6A$ $V_{GS}=4.5V$		1.2	1.5	nC
Gate-source charge	Q_{gs}			0.2		
Gate-drain charge	Q_{gd}			0.3		
Turn-on delay time	$t_{d(ON)}$	$V_{DD}=10V$ $V_{GEN}=4.5V$ $I_D=0.5A$ $R_L=10\Omega$ $R_G=6\Omega$		5	10	ns
Rise time	tr			8	15	
Turn-off delay time	$t_{d(OFF)}$			10	18	
Fall time	tf			1.2	2.8	

Notes:

- surface mounted on FR4 board, $t_s \leq 10\text{sec}$
- pulse test: pulse width $\leq 300\mu s$, duty $\leq 2\%$
- guaranteed by design, not subject to production testing

Thermal Characteristics

Thermal Resistance junction-to ambient	$R_{th JA}$	100	$^\circ C/W$
--	-------------	-----	--------------

Typical Performance Characteristics

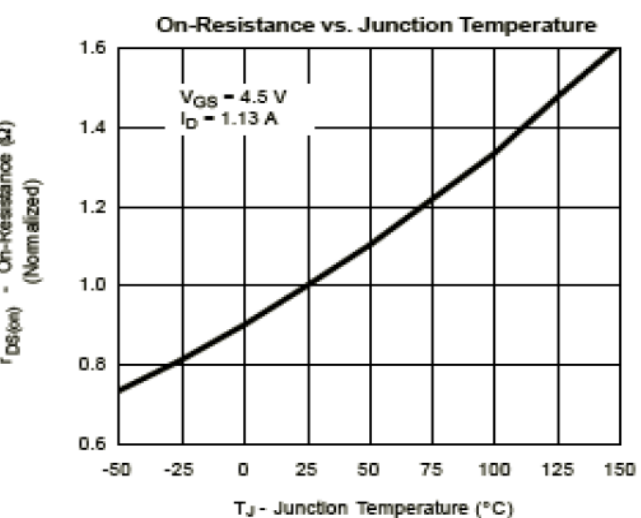
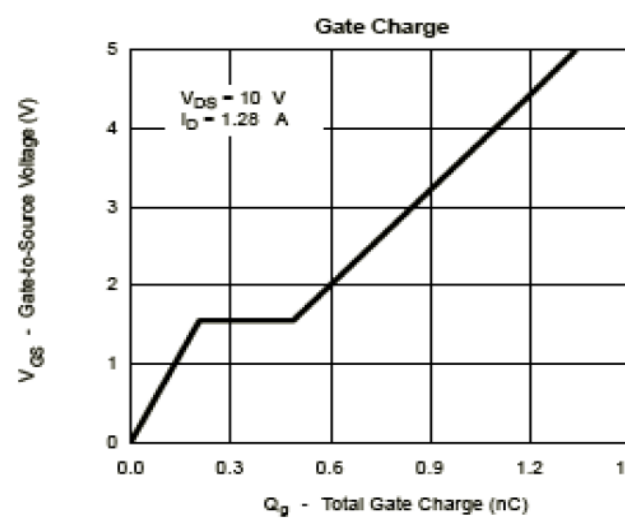
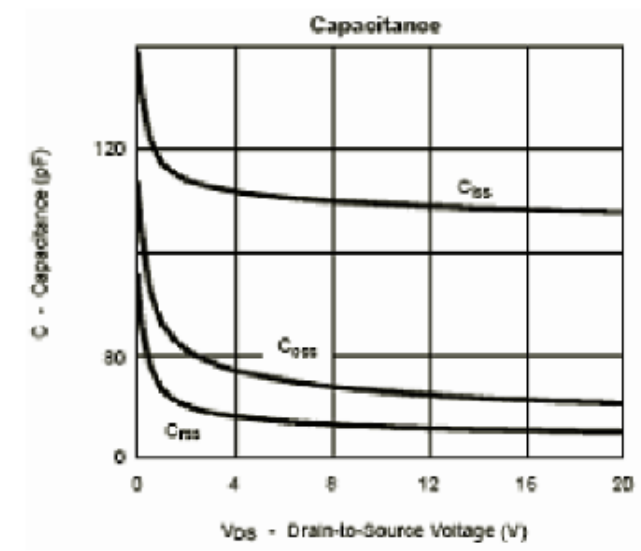
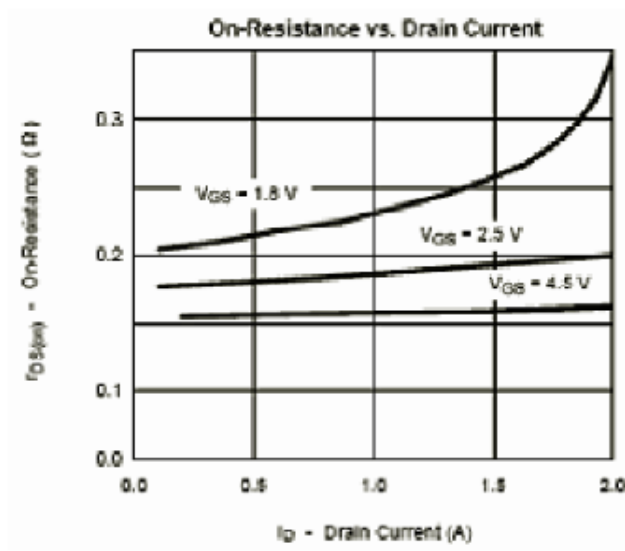
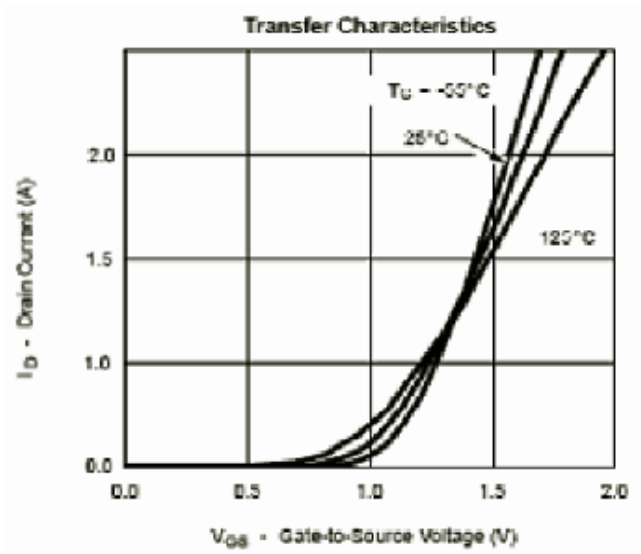
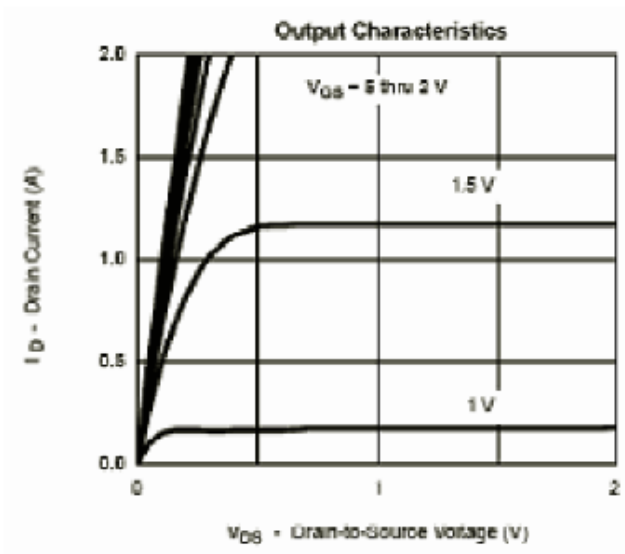

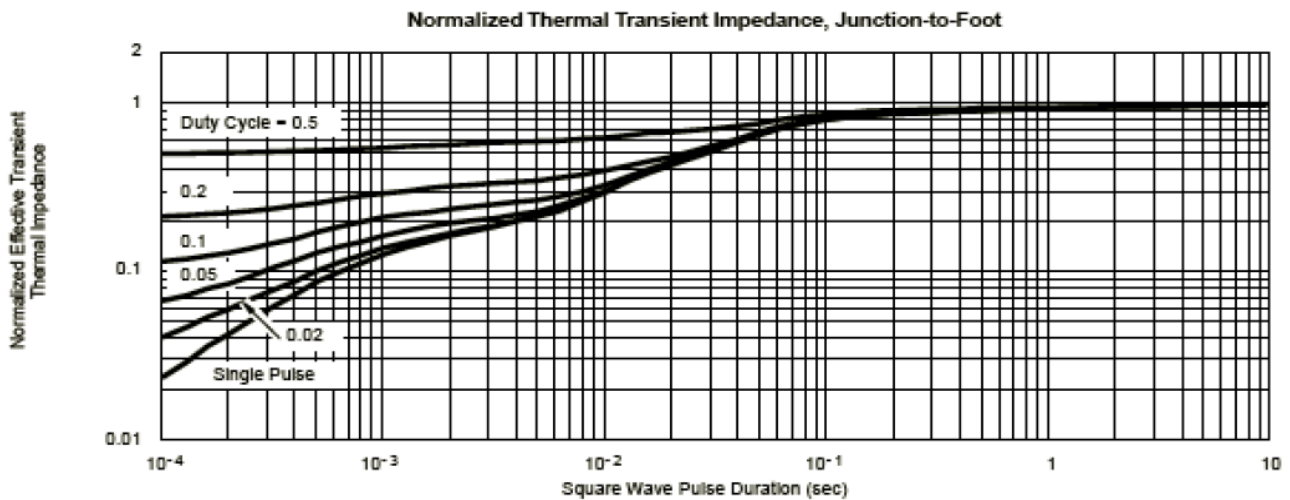
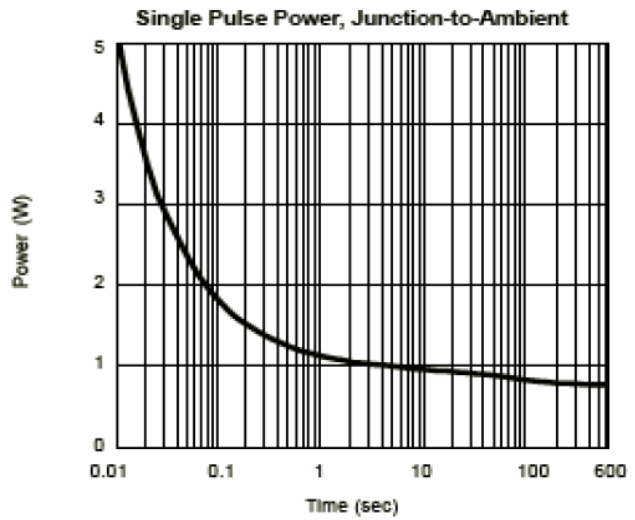
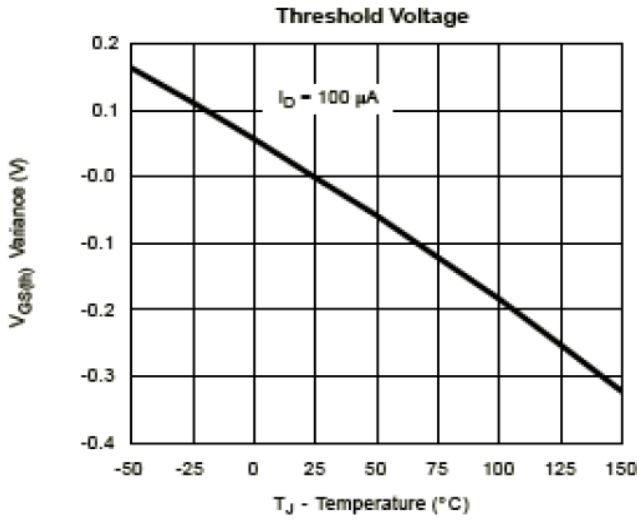
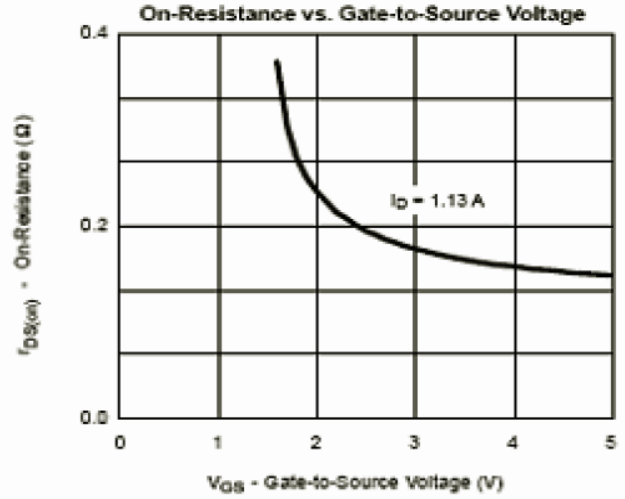
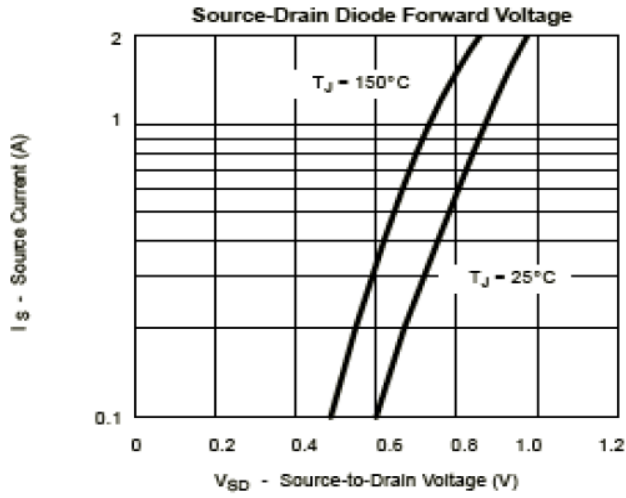

Package Information

- SOT-323

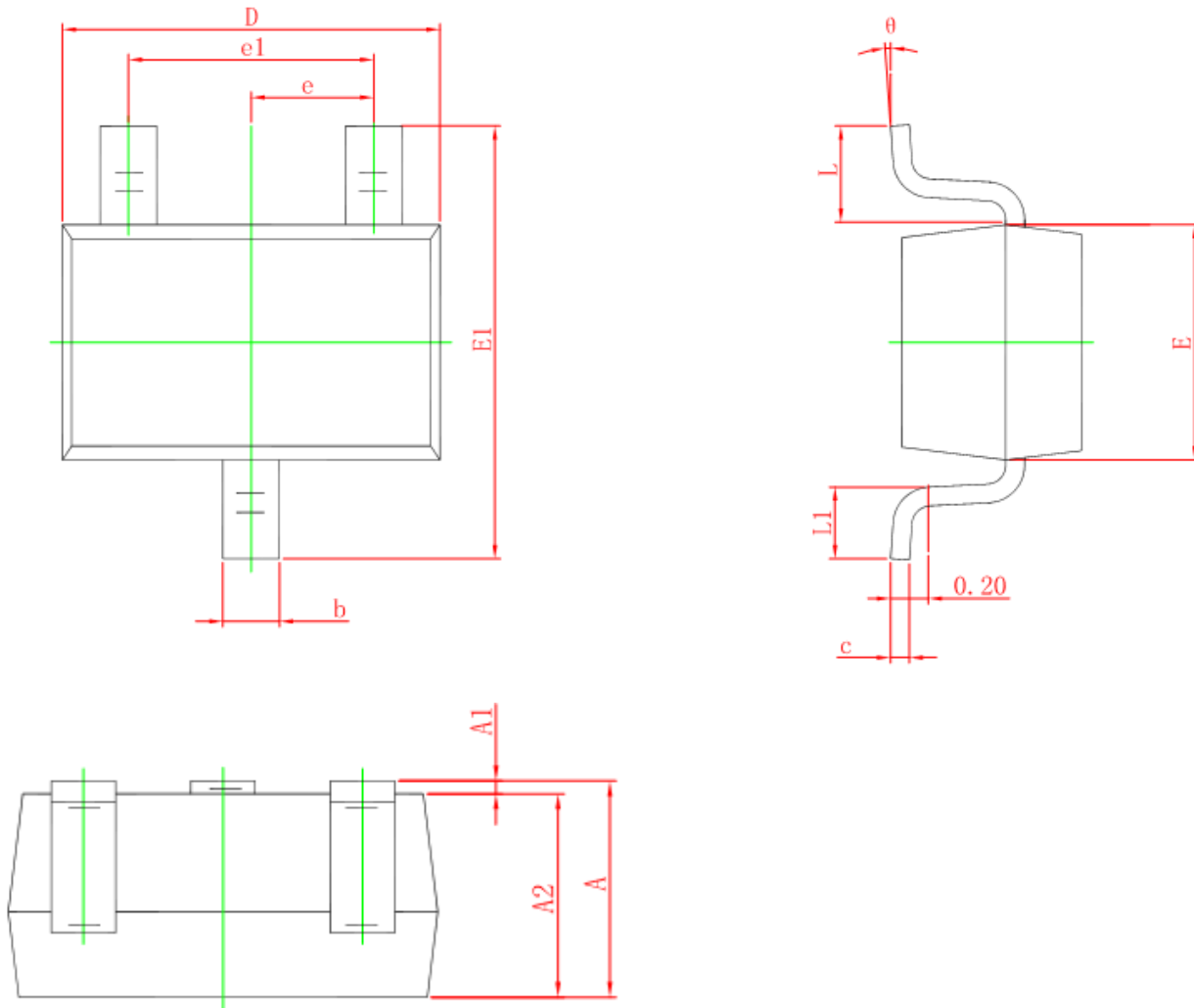

Symbol	Dimensions In Millimeters		Dimensions In Inches	
	Min	Max	Min	Max
A	0.900	1.100	0.035	0.043
A1	0.000	0.100	0.000	0.004
A2	0.900	1.000	0.035	0.039
b	0.200	0.400	0.008	0.016
c	0.080	0.150	0.003	0.006
D	2.000	2.200	0.079	0.087
E	1.150	1.350	0.045	0.053
E1	2.150	2.450	0.085	0.096
e	0.650 TYP		0.026 TYP	
e1	1.200	1.400	0.047	0.055
L	0.525 REF		0.021 REF	
L1	0.260	0.460	0.010	0.018
θ	0°	8°	0°	8°