

## PWM/PFM Automatic Switching Controlled Synchronous DC-DC Converters

### General Description

LN2405 series is a group of high efficiency synchronous-rectification type buck regulator using a constant frequency, current mode architecture. The device is available in an adjustable version and fixed output voltages of 1.8V and 3.3V. Automatic PWM/PFM mode operation increases efficiency and decreases output voltage ripple at light loads, further extending battery life. Switching frequency is internally set at 1.4MHz, allowing the use of small surface mount inductors and capacitors. 100% duty cycle provides low dropout operation.

### Features

- High Efficiency: 92%
- Input Voltage Range: 2.0 ~ 6.0V
- Output Current: 800mA
- Shutdown Current: <1uA
- Oscillation Frequency: 1.4MHz

### Typical Application Circuit

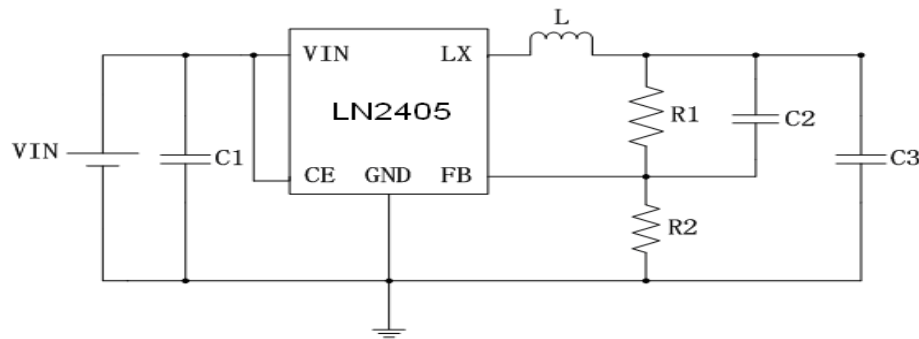

### Ordering Information

LN2405 ①②③④⑤

Designator	Symbol				Description
①	1	1	3	4	Output Voltage: 1.2V、1.8V、3.3V、4.2V
②	2	8	3	2	Adjustable version: ① ② fixed as 00
③	F				Oscillation Frequency 1.4MHz
④	M				Package Types: SOT-25
⑤	S				Embossed Tape :Standard Feed
	R				Embossed Tape :Reverse Feed

For example: LN240500FMR said package pins is defined as LN2405, external feedback, the oscillator frequency of 1.4MHz, Package SOT-25, Reverse Feed.

### Applications

- Cellular and Smart Phones
- PDAs
- MP3/MP4 Player
- Digital Still and Video Cameras
- Microprocessors and DSP Core Supplies
- Portable Instruments

### Package

- SOT-23-5L

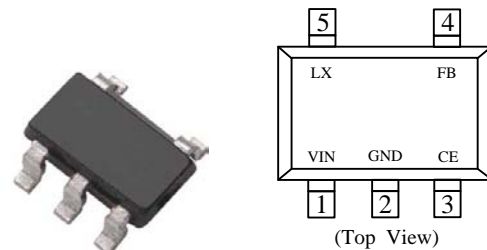

## Functional Pin Description

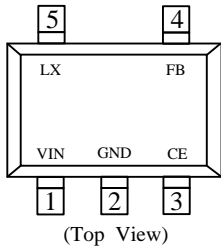

Pin Number	Pin Name	Function
3	CE	Chip Enable Pin
2	GND	Common Ground
5	LX	Switching Output
1	VIN	Power Input
4	FB	Feedback/Output Voltage Pin

## Marking Rule

- SOT-23-5L

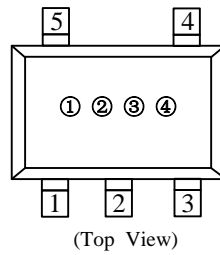

- ① Represents the product name

Symbol	Product Name
5	LN2405◆◆◆◆◆

- ② ③ Represents the Product Classification

Symbol		Number	Description
②	Feedback mode	0	Adjustive
		2	1.2V
		8	1.8V
		3	3.3V
		4	4.2V
③	Working mode	P	PWM/PFM
		B	PWM/BURST

- ④ Represents the assembly lot No.

0-9, A-Z; 0-9, A-Z mirror writing, repeated (G, I, J, O, Q, W exception)

■ Function Block Diagram

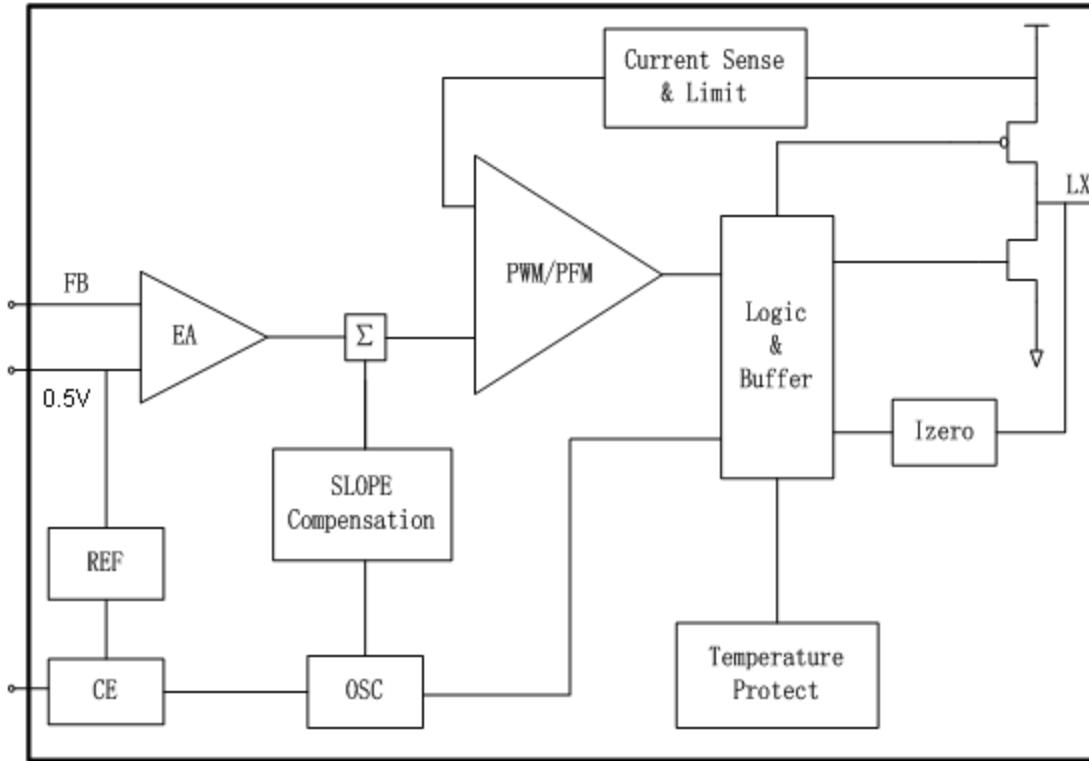

■ Absolute Maximum Ratings

Parameter	Symbol	Ratings	Units
Input Supply Voltage	V <sub>IN</sub>	-0.3~6.5	V
Output Voltage	V <sub>OUT</sub>	-0.3~6.5	
	V <sub>LX</sub>	-0.3~V <sub>IN</sub> + 0.3	
CE Voltage	V <sub>CE</sub>	-0.3~V <sub>IN</sub> + 0.3	V
Peak LX Current	I <sub>LX</sub>	±1000	mA
Power Dissipation	SOT-23-5L P <sub>D</sub>	250	mW
Operating Temperature Range	T <sub>opr</sub>	-40~+85	°C
Storage Temperature Range	T <sub>stg</sub>	-55~+125	

**Note:** Absolute Maximum Ratings are those values beyond which the life of a device may be impaired.

## Electrical Characteristics

VIN=3.6V ,CIN=4.7uF ,CL=10uF ,L=2.2uH

(Ta=25°C, unless otherwise noted)

Parameter	Symbol	Conditions	MIN	TYP	MAX	Units	Test Circuits
Feedback Voltage	VFB	-	0.49	0.5	0.51	V	1
Input Voltage Range	VIN		2	-	6		
Load regulation	VOUT	IL <sub>MAX</sub> =600mA		0.5		%	
Line regulation	ΔVOUT	IL=300mA		0.45		%	
Efficiency	EFFI	VIN=2.7V; IL=100mA	-	92	-	%	
CE "Low" voltage	VCEL	-	1.8			V	
CE "High" voltage	VCEH	-			1.4	V	
Stand-by Current	ISTB	VCE=0V、VIN=3.6V	0	-	1	uA	3
Quiescent Current	IDD	VFB=0.6V*0.9	-	200	-	uA	
Output Current Limit	ILIM	-	-	1200	-	mA	
PFM switching point	IL	VIN=3.6V、VOUT=1.8V		150		mA	
Oscillation Frequency	FOSC		-	1.4	-	MHz	2
Maximum Duty Circle	MAXDTY	-	100	-	-	%	

## Test Circuits

Parameters: LX=2.2uH, C1=4.7uF, C2=22pF, C3=10uF.

According to the required output voltage regulate R1, R2, so V<sub>FB</sub> = 0.5V.

**Circuit 1**

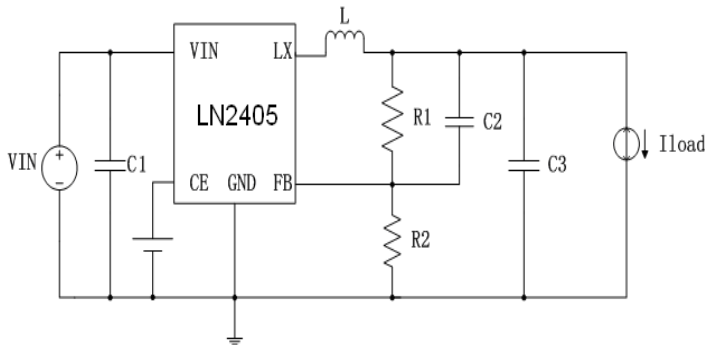

**Circuit 2**

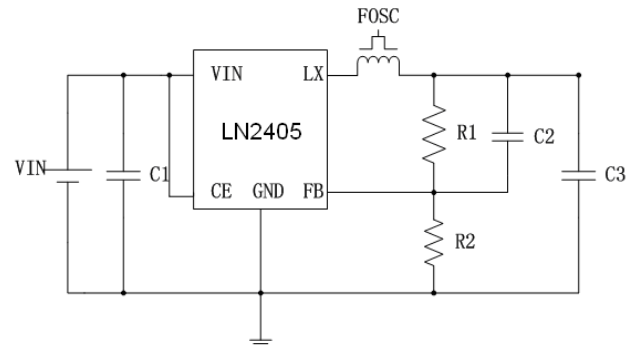

**Circuit3**

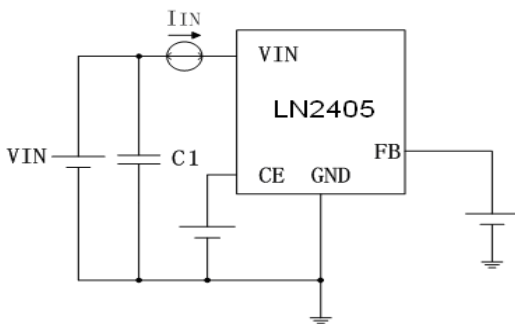

Typical Performance Characteristics

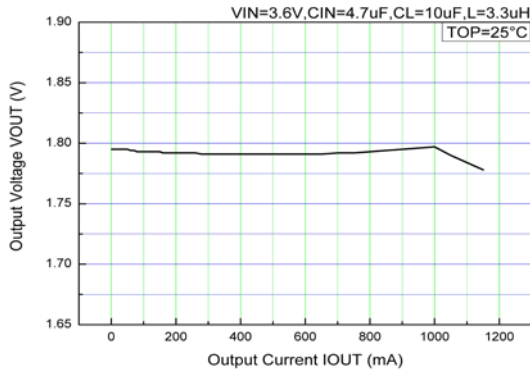

Output voltage vs output current

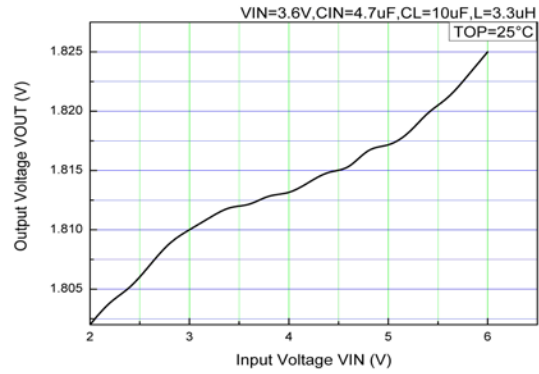

Input voltage vs output voltage

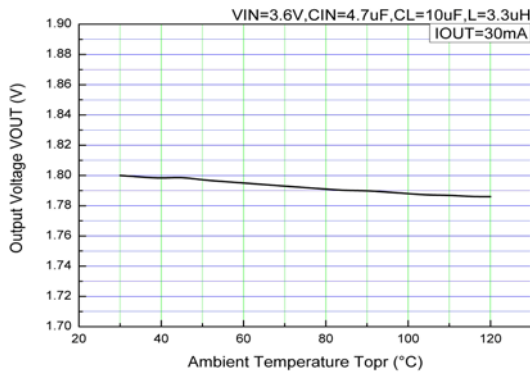

Output voltage vs Temperature

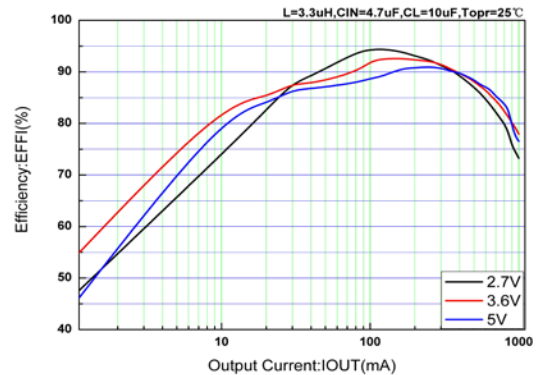

1.8V Efficiency vs output current

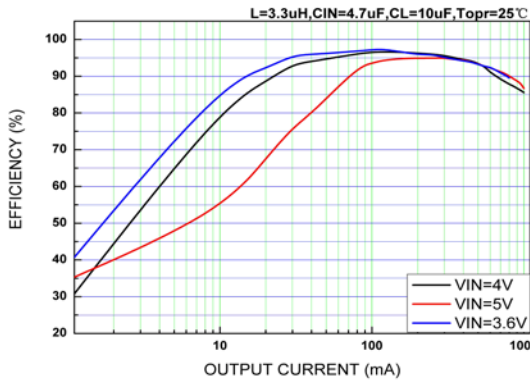

3.3V Efficiency vs output current

Package Information

- SOT-23-5L

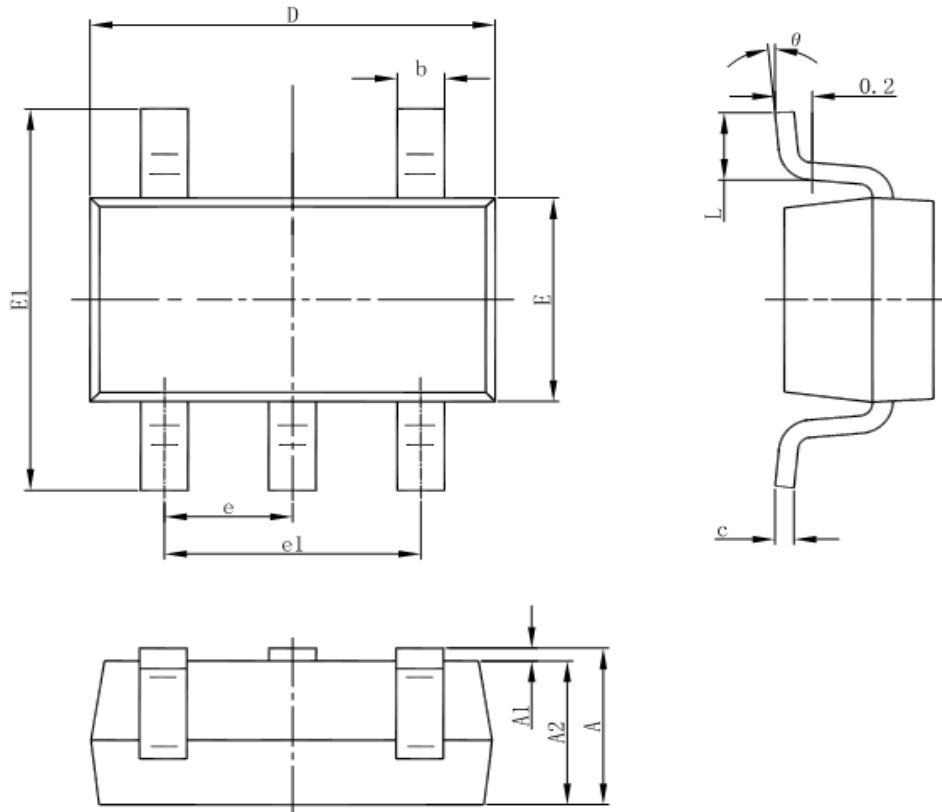

Symbol	Dimensions In Millimeters		Dimensions In Inches	
	Min	Max	Min	Max
A	1.050	1.250	0.041	0.049
A1	0.000	0.100	0.000	0.004
A2	1.050	1.150	0.041	0.045
b	0.300	0.500	0.012	0.020
c	0.100	0.200	0.004	0.008
D	2.820	3.020	0.111	0.119
E	1.500	1.700	0.059	0.067
E1	2.650	2.950	0.104	0.116
e	0.950(BSC)		0.037(BSC)	
e1	1.800	2.000	0.071	0.079
L	0.300	0.600	0.012	0.024
$\theta$	0°	8°	0°	8°