

## Low Current Consumption, High Sensitivity CMOS Hall IC

### General Description

The LN4915 is an integrated hall-effect sensor designed specifically to meet the requirements of low-power devices. e.g. as an On/Off switch in cellular flip-phones, with battery operating voltages of 2.0V-5.5V. Precise magnetic switching points and high temperature stability are achieved through the unique design of the internal circuit. An onboard clock scheme is used to reduce the average operating current of the IC. During the operate phase the IC compares the actual magnetic field detected with the internally compensated switching points. The output Voltage is switched at the end of each operating phase. During the Stand-by phase the output stage is latched and the current consumption of the device reduced to some  $\mu\text{A}$ .

The IC switching behavior is omnipolar, it can be switched on with either the north or south pole of a magnet. LN4915 is higher sensitivity of magnetic induction than LN4913, it can be used in security systems、sensing magnet smaller occasions.

### Features

- Micro power design
- 2.0 V to 5.5 V battery operation
- High sensitivity and high stability of the magnetic Switching points
- High resistance to mechanical stress
- Digital output signal
- Switching for both poles of a magnet (omnipolar)
- Not suitable for automotive application

### Operating Parameters

- Operating temperature range

$$T_{\text{MIN}} \leq T_A \leq T_{\text{MAX}} \quad -40^{\circ}\text{C} \leq T_A \leq 85^{\circ}\text{C}$$

- Operating voltage range  $2.0\text{V} \leq \text{VDD} \leq 6.0\text{V}$

### Application

- Mobile phones
- Notebook
- Portable electronic devices

### Package

- SOT23-3L
- TSOT23-3L
- TO-92
- TO-92S

### Typical Application Circuit

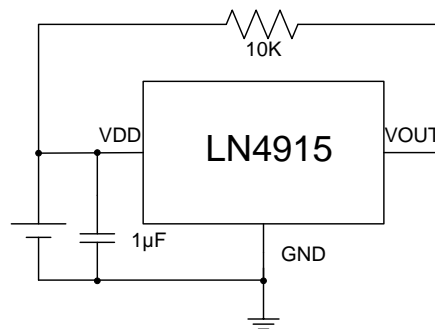

### Ordering Information

Part Number	Package Code	Package	Part Number	Package Code	Package
LN4915MR	M	SOT23-3L	LN4915SRA	S	TO-92S
LN4915NR	N	TSOT23-3L	LN4915TRB	T	TO-92
LN4915TR	T	TO-92	LN4915SRB	S	TO-92S
LN4915SR	S	TO-92S	LN4915TRA	T	TO-92

## Pin Configuration

- SOT23-3L, TSOT23-3L

Pin number	Pin Name	Function
2	VOUT	输出端
3	GND	接地端
1	VDD	电源电压

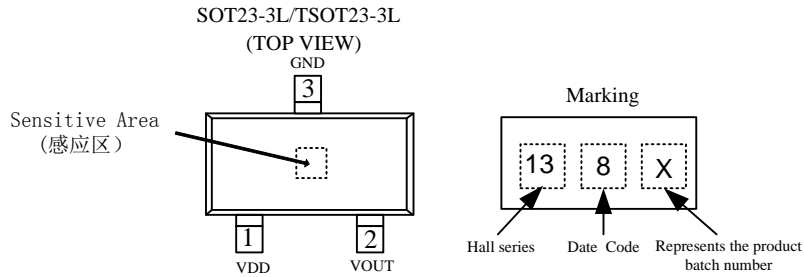

Note: X is defined by production

- TO-92, TO-92S

Ordering Name	Package	Pin Name			Marking
		1	2	3	
LN4915TR	TO-92	VDD	VOUT	GND	4915
LN4915SR	TO-92S	VDD	VOUT	GND	4915
LN4915TRA	TO-92	VOUT	GND	VDD	4915A
LN4915SRA	TO-92S	VOUT	GND	VDD	4915A
LN4915TRB	TO-92	VDD	GND	VOUT	4915B
LN4915SRB	TO-92S	VDD	GND	VOUT	4915B

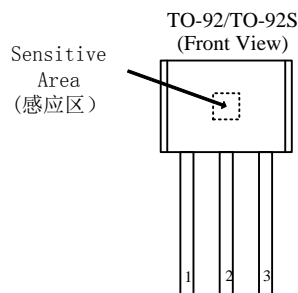

## Function Block Diagram

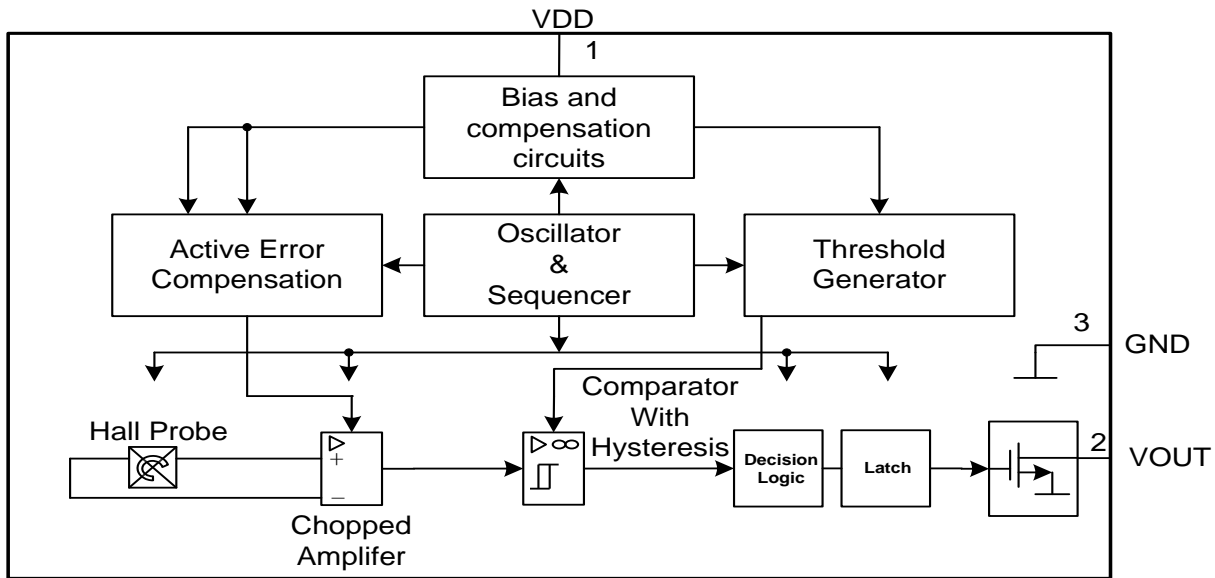

## Absolute Maximum Ratings

Symbol	Characteristics	Values	Unit
V <sub>DD</sub>	Supply voltage	2.0-6.0	V
I <sub>DD</sub>	Operating current	-1-4.5	mA
V <sub>OUT</sub>	Output voltage	-0.3-6.0	V
I <sub>OUT</sub>	Output current	-1-2.0	mA
T <sub>S</sub>	Storage temperature range	-40~+150	°C
T <sub>J</sub>	Maximum junction temperature	150	°C
ESD	ESD Protection	4000	V

## Electrical Characteristics

AC/DC Characteristics (T<sub>A</sub>=+25°C, V<sub>DD</sub>=3.0V, Unless otherwise specified)

Symbol	Characteristic	Conditions	Min	Typ	Max	Unit
V <sub>DD</sub>	Supply voltage	—	2.0	—	5.5	V
I <sub>SAVG</sub>	Averaged supply current	—	1	3	10	uA
I <sub>SOPAVG</sub>	Averaged current during operating time	—	0.5	2.0	3.5	mA
I <sub>SOPT</sub>	Peak current during operating time	—	—	—	4.5	mA
I <sub>SSTB</sub>	Supply current during standby time	—	1	1.9	8	uA
V <sub>QSAT</sub>	Output Saturation Voltage	I <sub>OUT</sub> =1mA	—	0.13	0.4	V
I <sub>QLEAK</sub>	Output on Leakage Current	—	—	0.01	1	uA
t <sub>r</sub>	Output rise time	R <sub>L</sub> =2.7KΩ, C <sub>L</sub> =10pF	—	0.5	1	us
t <sub>f</sub>	Output fall time	R <sub>L</sub> =2.7KΩ, C <sub>L</sub> =10pF	—	0.1	1	us
t <sub>op</sub>	Operating time	—	25	100	160	us
t <sub>stb</sub>	Standby time	—	60	140	240	ms
t <sub>op</sub> /t <sub>stb</sub>	Duty cycle	—	—	0.071	—	%
t <sub>sttu</sub>	Start-up time of IC	—	—	12	20	us

## ■ Magnetic Characteristics

( $T_A=+25^{\circ}\text{C}$ ,  $V_{DD}=2.7\text{V}$ , Unless otherwise specified)

Symbol	Min	Typ	Max	Unit
BOPS	1	1.5	2	mT
BOPN	-2	-1.5	-1	mT
BRPS	0.8	1.1	1.5	mT
BRPN	-1.8	-1.1	-0.8	mT
BHYS	0.1	0.4	0.7	mT

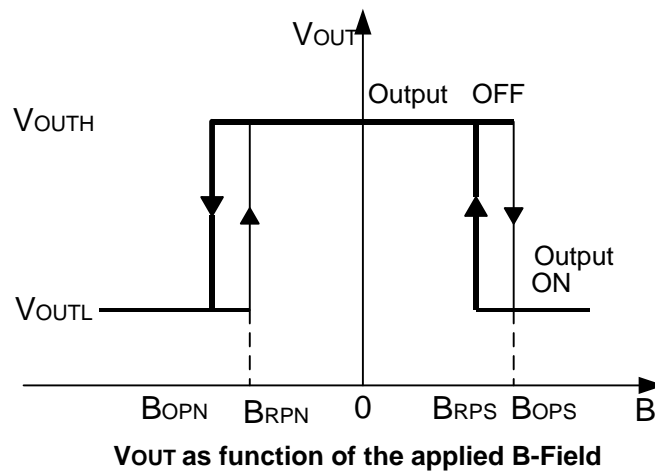
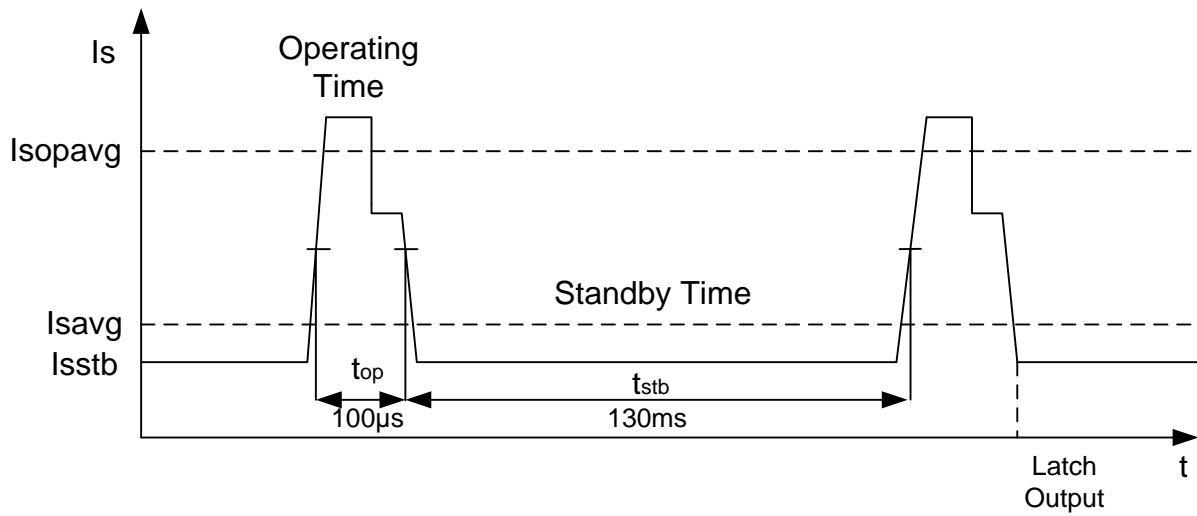

**Package**

- SOT23-3L

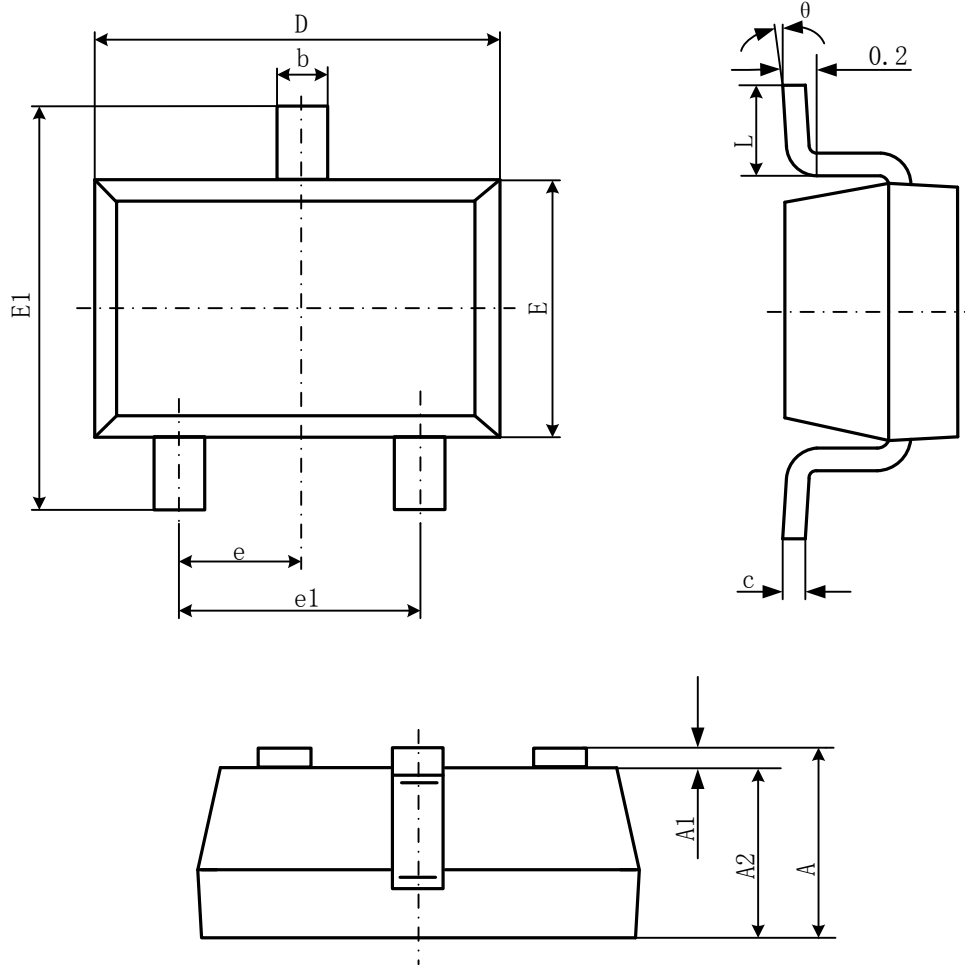

Symbol	Dimensions In Millimeters		Dimensions In Inches	
	Min	Max	Min	Max
A	1.050	1.250	0.041	0.049
A1	0.000	0.100	0.000	0.004
A2	1.050	1.150	0.041	0.045
b	0.300	0.500	0.012	0.020
c	0.100	0.200	0.004	0.008
D	2.820	3.020	0.111	0.119
E	1.500	1.700	0.059	0.067
E1	2.650	2.950	0.104	0.116
e	0.950(BSC)		0.037(BSC)	
e1	1.800	2.000	0.071	0.079
L	0.300	0.600	0.012	0.024
$\theta$	0°	8°	0°	8°

## ● TSOT23-3L

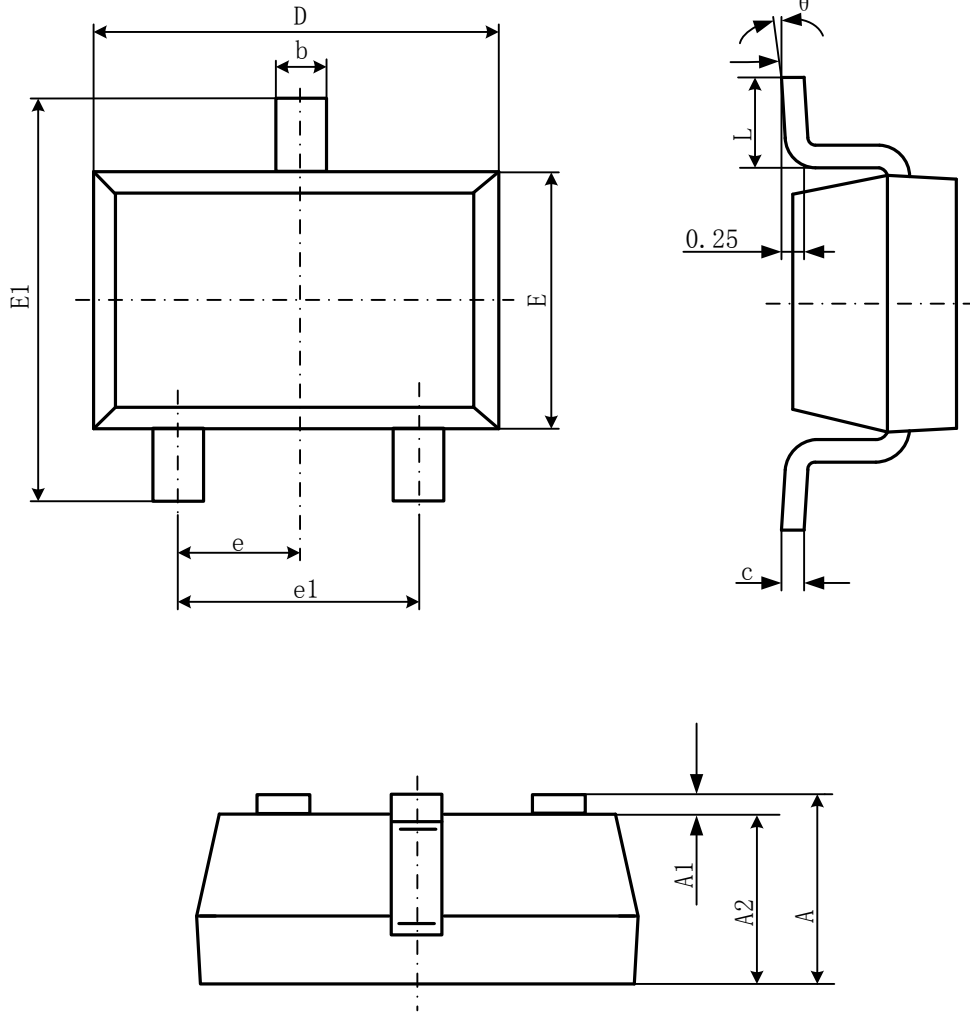

Symbol	Dimensions In Millimeters		Dimensions In Inches	
	Min	Max	Min	Max
A	0.700	0.900	0.028	0.035
A1	0.000	0.100	0.000	0.004
A2	0.700	0.800	0.028	0.031
b	0.350	0.500	0.014	0.020
c	0.080	0.200	0.003	0.008
D	2.820	3.020	0.111	0.119
E	1.600	1.700	0.063	0.067
E1	2.650	2.950	0.104	0.116
e	0.950(BSC)		0.037(BSC)	
e1	1.90(BSC)		0.075(BSC)	
L	0.300	0.600	0.012	0.024
$\theta$	0°	8°	0°	8°

## ● TO-92

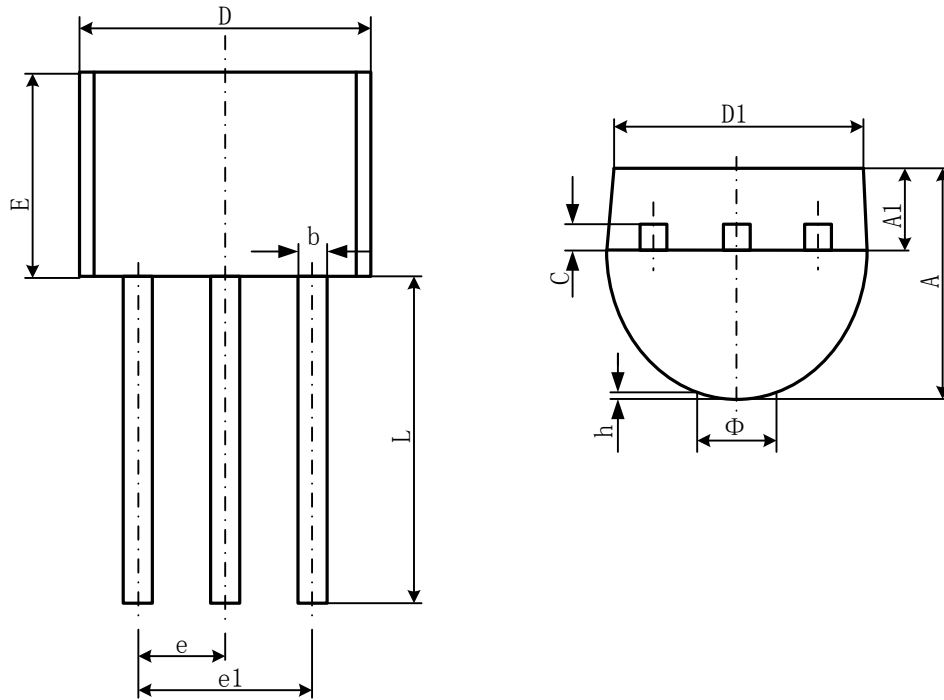

Symbol	Dimensions In Millimeters		Dimensions In Inches	
	Min	Max	Min	Max
A	3.300	3.700	0.130	0.146
A1	1.100	1.400	0.043	0.055
b	0.380	0.550	0.015	0.022
c	0.360	0.510	0.014	0.020
D	4.400	4.700	0.173	0.185
D1	3.430	-	0.135	-
E	4.300	4.700	0.169	0.185
e	1.270TYP		0.050TYP	
e1	2.440	2.640	0.096	0.104
L	14.100	14.500	0.555	0.571
Φ	-	1.600	-	0.063
h	0.000	0.380	0.000	0.015

## ● TO-92S

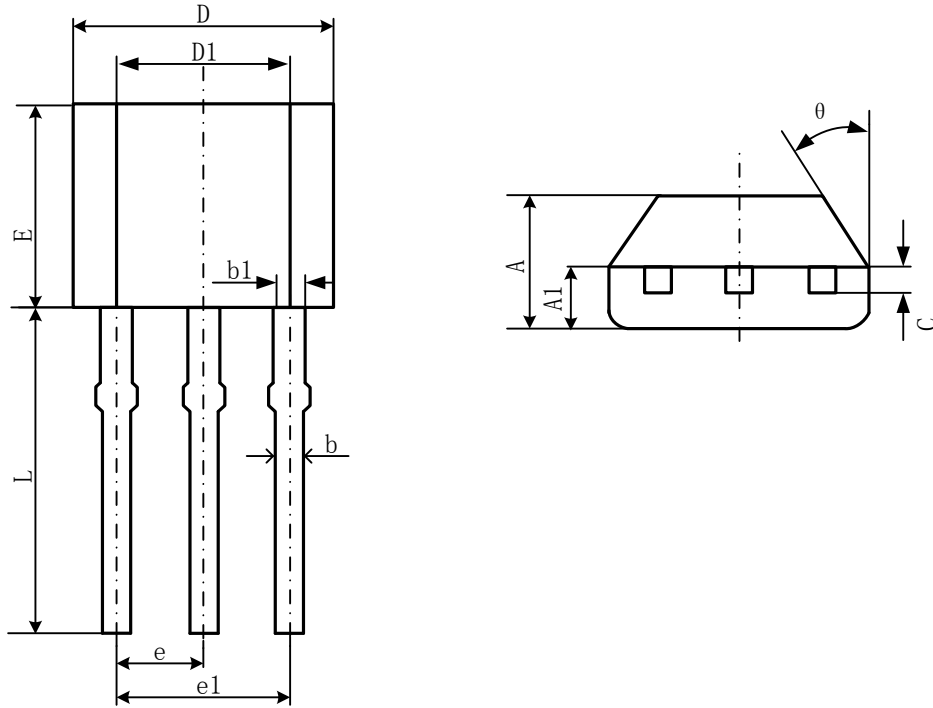

Symbol	Dimensions In Millimeters		Dimensions In Inches	
	Min	Max	Min	Max
A	1.420	1.620	0.056	0.064
A1	0.660	0.860	0.026	0.034
b	0.350	0.480	0.014	0.019
b1	0.400	0.550	0.016	0.022
c	0.360	0.510	0.014	0.020
D	3.900	4.100	0.154	0.161
D1	2.280	2.680	0.090	0.106
E	3.050	3.250	0.120	0.128
e	1.270TYP		0.050TYP	
e1	2.440	2.640	0.096	0.104
L	15.100	15.500	0.594	0.610
θ	45° TYP		45° TYP	