

## 2 Watt Audio Power Amplifier with Selectable Shutdown Logic Level

### ■ General Description

The LN4990 is an audio power amplifier primarily designed for demanding applications in mobile phones and other portable communication device applications. It is capable of delivering 1.25 watts of continuous average power to an 8Ω BTL load and 2 watts of continuous average power (LD and MH only) to a 4Ω BTL load with less than 1% distortion (THD+N) from a 5VDC power supply. Boomer audio power amplifiers were designed specifically to provide high quality output power with a minimal amount of external components. The LN4990 does not require output coupling capacitors or bootstrap capacitors, and therefore is ideally suited for mobile phone and other low voltage applications where minimal power consumption is a primary requirement.

The LN4990 features a low-power consumption shutdown mode. To facilitate this, Shutdown may be enabled by either logic high or low depending on mode selection. Driving the shutdown mode pin either high or low enables the shutdown pin to be driven in a likewise manner to enable shutdown.

The LN4990 contains advanced pop & click circuitry which eliminates noise which would otherwise occur during turn-on and turn-off transitions. The LN4990 is unity-gain stable and can be configured by external gain-setting resistors.

### ■ Key Specifications

- PSRR@fIN=217Hz, VDD=5V 62dB(TYP)
- Power Output@VDD=5V&1%THD 4Ω 2W(TYP)
- Power Output@VDD=5V&1%THD 8Ω 1.25W(TYP)
- Power Output@VDD=3V&1%THD 4Ω 600mW(TYP)
- Power Output@VDD=3V&1%THD 8Ω 425mW(TYP)
- Shutdown Current 0.1μA(TYP)

### ■ Features

- Available in space-saving packages: WCSP、MSOP
- Ultra low current shutdown mode
- Improved pop & click circuitry eliminates noise during
- Turn-on and turn-off transitions
- 2.2 - 5.5V operation
- No output coupling capacitors, snubber networks or bootstrap capacitors required
- Unity-gain stable
- External gain configuration capability
- User selectable shutdown high or low logic Level

### ■ Applications

- Mobile Phones
- PDAs
- Portable electronic devices

### ■ Package

- WCSP
- MSOP-8

### ■ Ordering Information

Ordering Number	Package	Mark
LN4990ITL	WCSP	XYD2
LN4990MM	MSOP-8	XXXX

### ■ Operating Ratings

Temperature Range

TMIN ≤ TA ≤ TMAX----- -40°C ≤ TA ≤ 85°C

Supply Voltage ----- 2.2V ≤ VDD ≤ 5.5V

■ Pin Configuration

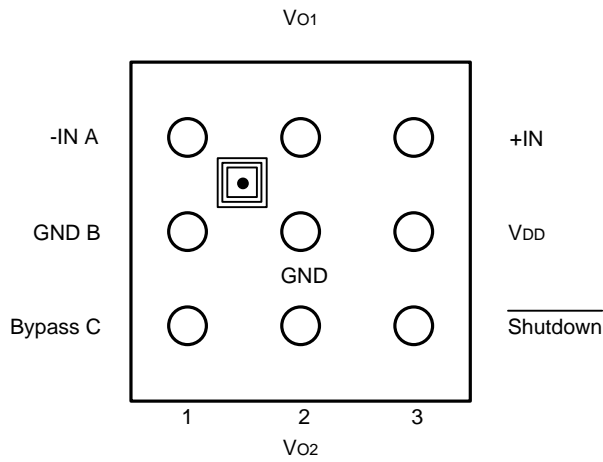

(Top-View)

Ordering Number: LN4990ITL

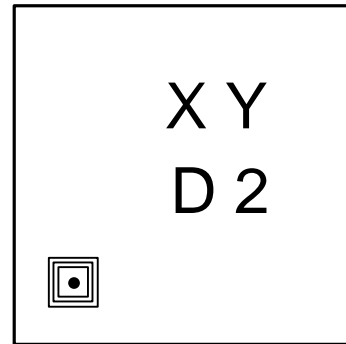

XY-----Product Lot Number

D2-----LN4990ITL

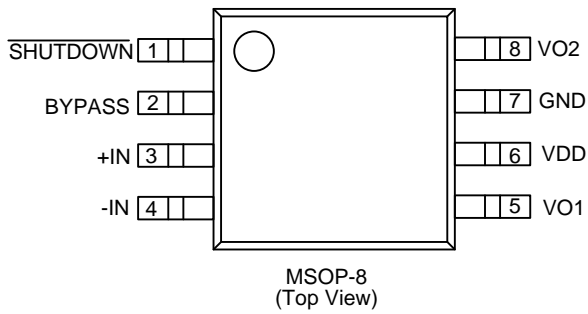

MSOP-8  
(Top View)

Ordering Number: LN4990MM

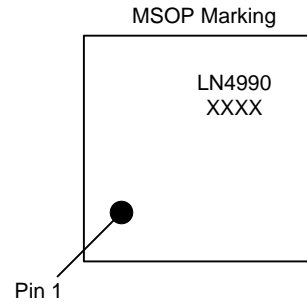

XXXX----- Product Lot Number

■ Function Block Diagram

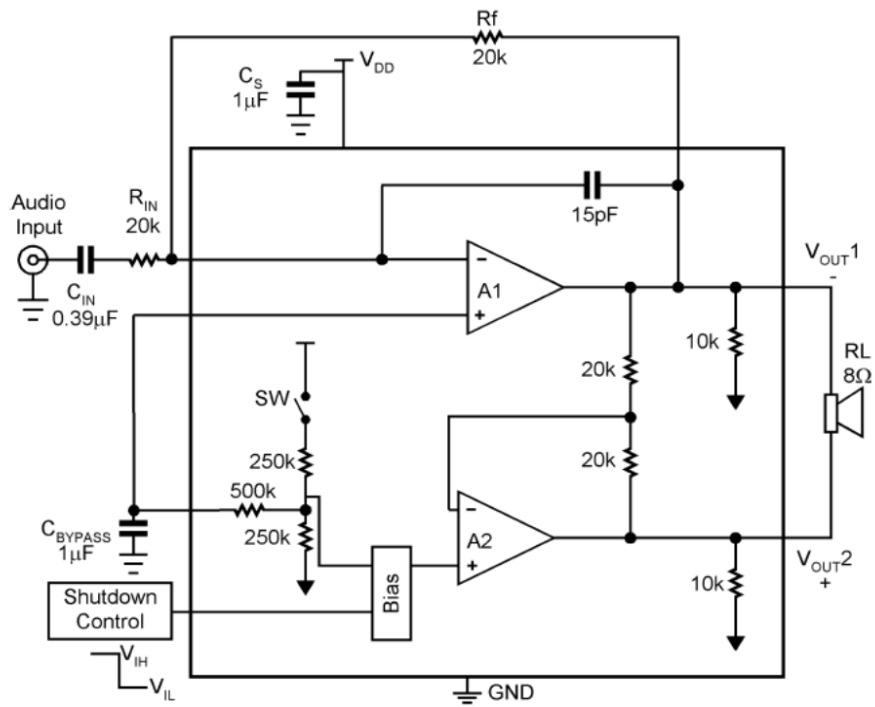

■ Absolute Maximum Ratings

Parameter	Symbol	Value	Unit
Supply Voltage	VDD	-0.3—6.0	V
Input Voltage	VIN	-0.3—VDD+0.3	V
Operation Temperature	Topr	-40—85	°C
Storage Temperature	Tstg	-65—150	°C
ESD Susceptibility	-	4000	V

**Electrical Characteristics**

(VDD = 5V, Unless otherwise specified. Limits apply for TA = 25°C.)

Symbol	Parameters	Test Conditions	Min.	Typ.	Max.	Unit
I <sub>DD</sub>	Quiescent Power	V <sub>IN</sub> = 0V, I <sub>o</sub> = 0A, No Load	—	3	7	mA
	Supply Current	V <sub>IN</sub> = 0V, I <sub>o</sub> = 0A, 8Ω Load	—	4	10	mA
I <sub>SD</sub>	Shutdown Current	V <sub>SHUTDOWN</sub> = 0V	—	0.1	2	μA
V <sub>SDIH</sub>	Shutdown Voltage Input High	V <sub>SD MODE</sub> =VDD	—	1.5	—	V
V <sub>SDIL</sub>	Shutdown Voltage Input Low	V <sub>SD MODE</sub> =VDD	—	1.3	—	V
V <sub>SDIH</sub>	Shutdown Voltage Input High	V <sub>SD MODE</sub> =GND	—	1.5	—	V
V <sub>SDIL</sub>	Shutdown Voltage Input Low	V <sub>SD MODE</sub> =GND	—	1.3	—	V
V <sub>OS</sub>	Output Offset Voltage		—	7	50	mV
R <sub>OUT-GND</sub>	Resistor Output to GND		7.0	8.5	9.7	kΩ
P <sub>O</sub>	Output Power -8Ω	THD = 1% (max); f = 1 kHz	0.9	1.25	—	W
	Output Power -4Ω	THD = 1% (max); f = 1 kHz	—	2	—	W
T <sub>WU</sub>	Wake-up time		—	170	220	ms
T <sub>SD</sub>	Thermal Shut Down temperature		150	170	190	°C
THD+N	Total Harmonic Distortion+Noise	P <sub>o</sub> = 0.5 W <sub>rms</sub> ; f = 1kHz	—	0.2	—	%
PSRR	Power Supply Rejection Ratio	V <sub>ripple</sub> = 200mV <sub>sine p-p</sub> f=217Hz	55	60	—	dB
		V <sub>ripple</sub> = 200mV <sub>sine p-p</sub> f=1kHz		66		
T <sub>SDT</sub>	Shut Down Time	8Ω Load	—	1.0	—	ms

**(VDD = 3V , Unless otherwise specified. Limits apply for TA = 25°C.)**

Symbol	Parameters	Test Conditions	Min.	Typ.	Max.	Unit
I <sub>DD</sub>	Quiescent Power	V <sub>IN</sub> = 0V, I <sub>o</sub> = 0A, No Load	—	2	7	mA
	Supply Current	V <sub>IN</sub> = 0V, I <sub>o</sub> = 0A, 8Ω Load	—	3	9	mA
I <sub>SD</sub>	Shutdown Current	V <sub>SHUTDOWN</sub> = 0V	—	0.1	2	μA
V <sub>SDIH</sub>	Shutdown Voltage Input High	V <sub>SD MODE</sub> =VDD	—	1.1	—	V
V <sub>SDIL</sub>	Shutdown Voltage Input Low	V <sub>SD MODE</sub> =VDD	—	0.9	—	V
V <sub>SDIH</sub>	Shutdown Voltage Input High	V <sub>SD MODE</sub> =GND	—	1.3	—	V
V <sub>SDIL</sub>	Shutdown Voltage Input Low	V <sub>SD MODE</sub> =GND	—	1.0	—	V
V <sub>OS</sub>	Output Offset Voltage		—	7	50	mV
R <sub>OUT-GND</sub>	Resistor Output to GND		7.0	8.5	9.7	kΩ
P <sub>O</sub>	Output Power -8Ω	THD = 1% (max); f = 1 kHz	—	425	—	mW
	Output Power -4Ω	THD = 1% (max); f = 1 kHz	—	600	—	mW
T <sub>WU</sub>	Wake-up time		—	100	150	ms
T <sub>SD</sub>	Thermal Shut Down temperature		150	170	190	°C
THD+N	Total Harmonic Distortion+Noise	P <sub>o</sub> = 0.25 Wrms; f = 1kHz	—	0.1	—	%
PSRR	Power Supply Rejection Ratio	V <sub>ripple</sub> = 200mV <sub>sine p-p</sub> f=217Hz	45	62	—	dB
		V <sub>ripple</sub> = 200mV <sub>sine p-p</sub> f=1kHz		68		

**(VDD = 2.6V, Unless otherwise specified. Limits apply for TA = 25°C.)**

Symbol	Parameters	Test Conditions	Min.	Typ.	Max.	Unit
I <sub>DD</sub>	Quiescent Power Supply Current	V <sub>IN</sub> = 0V, I <sub>o</sub> = 0A, No Load	—	2.0	—	mA
I <sub>DD</sub>	Quiescent Power Supply Current	V <sub>IN</sub> = 0V, I <sub>o</sub> = 0A, 8Ω Load	—	3.0	—	mA
I <sub>SD</sub>	Shutdown Current	V <sub>SHUTDOWN</sub> = 0V	—	0.1	2	μA
P <sub>O</sub>	Output Power	THD = 1% (max); f = 1 kHz		8Ω Load	—	W
				4Ω Load		
THD+N	Total Harmonic Distortion+Noise	P <sub>o</sub> = 0.15 Wrms; f = 1kHz	—	0.1	—	%
PSRR	Power Supply Rejection Ratio	V <sub>ripple</sub> = 200mV <sub>sine p-p</sub> f=217Hz	—	51	—	dB
		V <sub>ripple</sub> = 200mV <sub>sine p-p</sub> f=1kHz		55		

Typical Performance Characteristics

THD+N vs Frequency  
at  $V_{DD} = 5V$ ,  $8\Omega R_L$ , and  $PWR = 250mW$ ,  $A_V = 2$

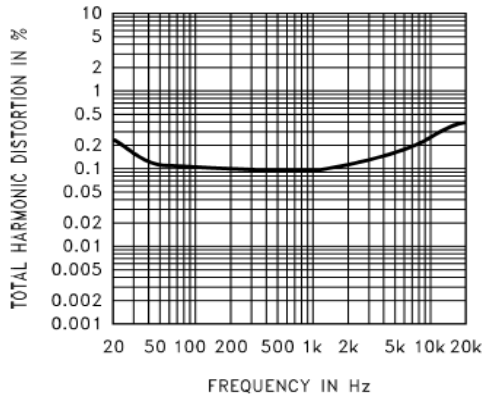

THD+N vs Frequency  
at  $V_{DD} = 3V$ ,  $R_L = 8\Omega$ ,  $PWR = 250mW$ ,  $A_V = 2$

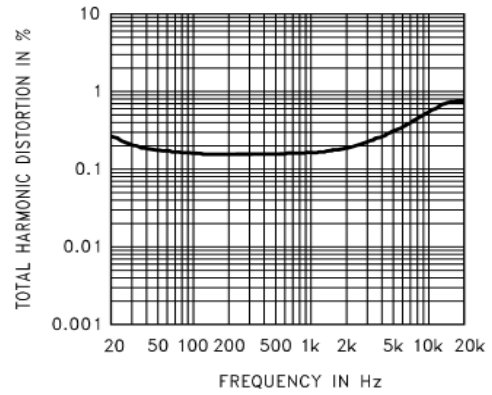

THD+N vs Power Out  
@  $V_{DD} = 5V$ ,  $R_L = 8\Omega$ ,  $1kHz$ ,  $A_V = 2$

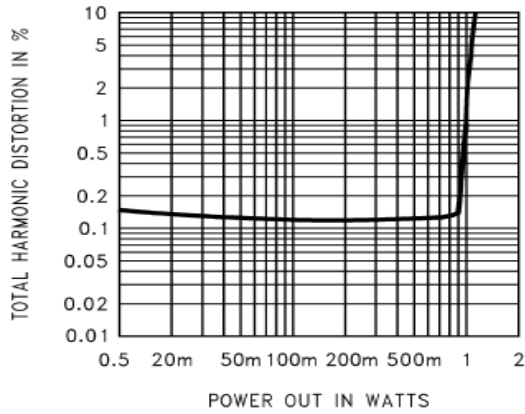

THD+N vs Power Out  
@  $V_{DD} = 3V$ ,  $R_L = 8\Omega$ ,  $1kHz$ ,  $A_V = 2$

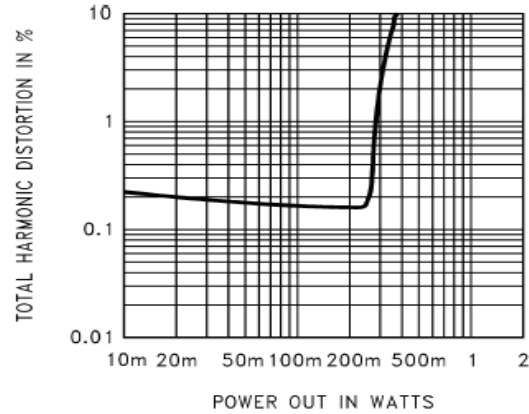

Power Supply Rejection Ratio (PSRR) @  $A_V = 2$   
 $V_{DD} = 5V$ ,  $V_{ripple} = 200mvp-p$   
 $R_L = 8\Omega$ ,  $R_{IN} = 10\Omega$

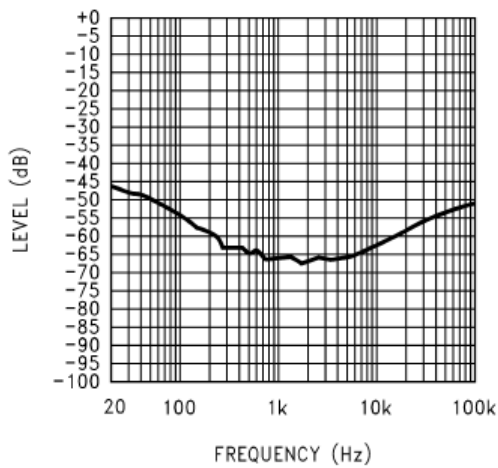

Power Supply Rejection Ratio (PSRR) @  $A_V = 4$   
 $V_{DD} = 5V$ ,  $V_{ripple} = 200mvp-p$   
 $R_L = 8\Omega$ ,  $R_{IN} = Float$

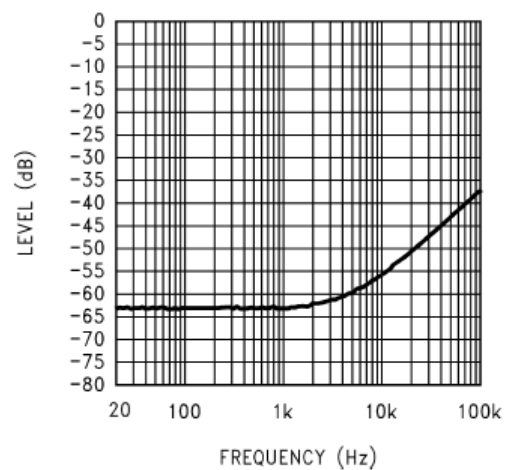

PSRR vs DC Output Voltage  
 $V_{DD} = 5V, A_V = 2$

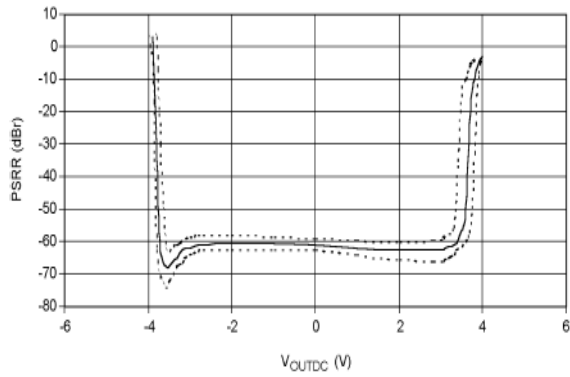

PSRR vs DC Output Voltage  
 $V_{DD} = 3V, A_V = 2$

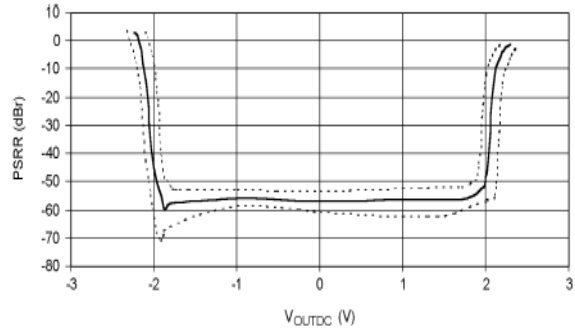

Power Derating Curves ( $P_{DMAX} = 670mW$ )

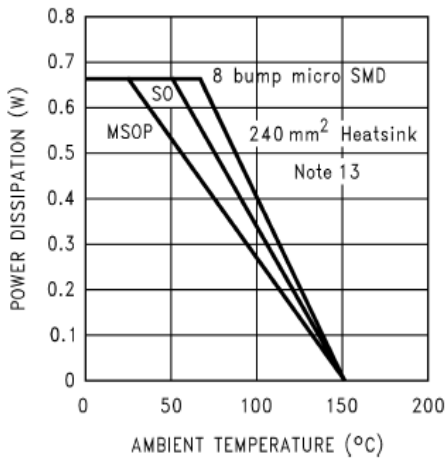

Power Derating - 8 bump  $\mu$ SMD ( $P_{DMAX} = 670mW$ )

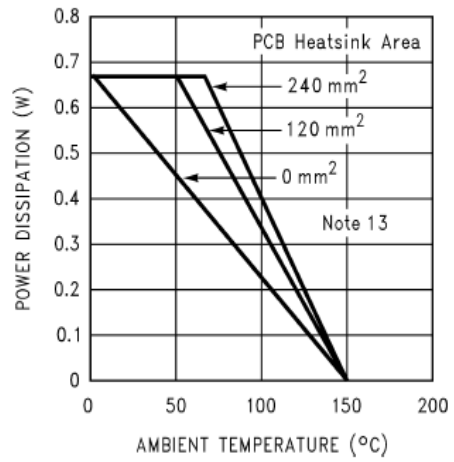

■ Package Information

- MSOP-8

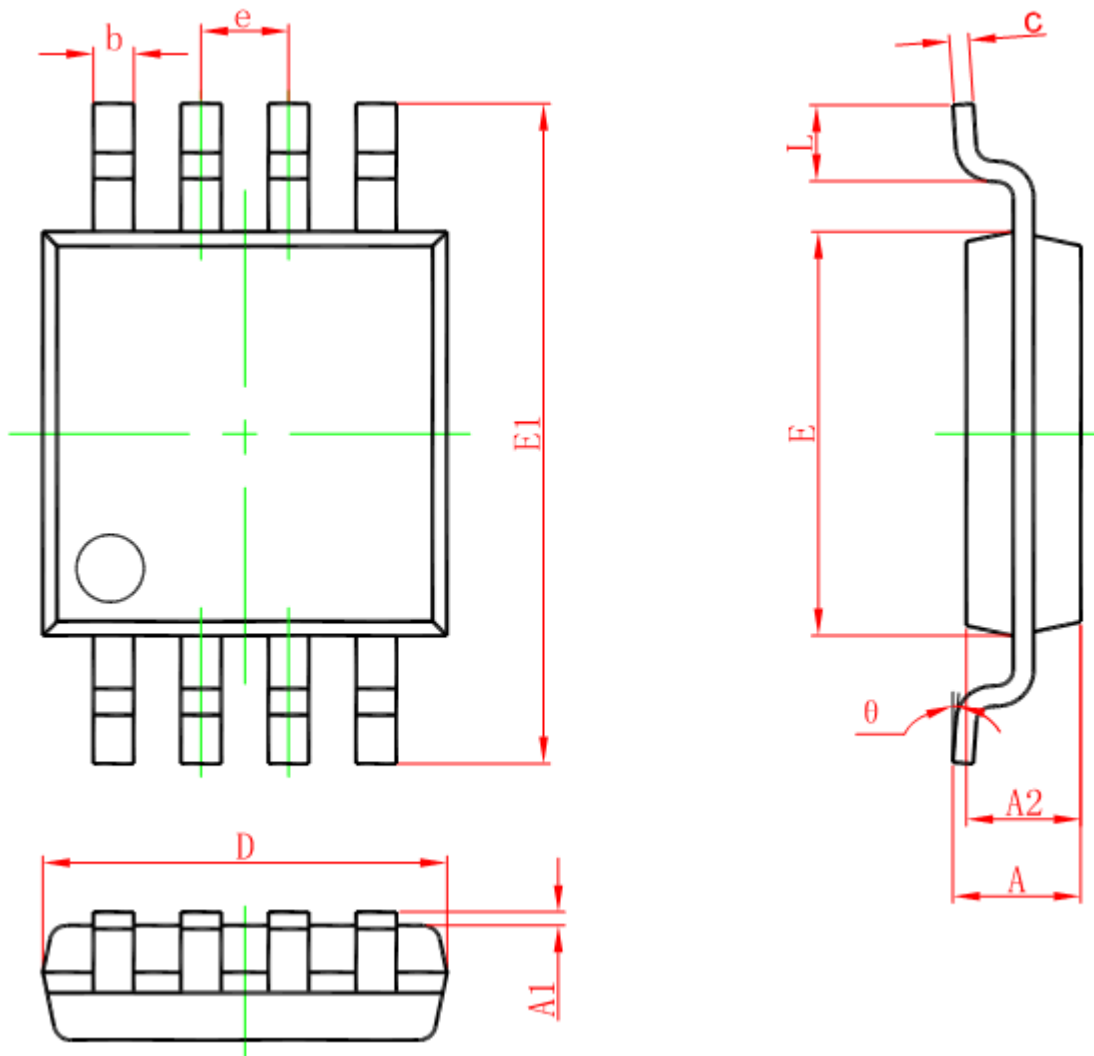

Symbol	Dimensions In Millimeters		Dimensions In Inches	
	Min	Max	Min	Max
A	0.820	1.100	0.032	0.043
A1	0.020	0.150	0.001	0.006
A2	0.750	0.950	0.030	0.037
b	0.250	0.380	0.010	0.015
c	0.090	0.230	0.004	0.009
D	2.900	3.100	0.114	0.122
e	0.650(BSC)		0.026(BSC)	
E	2.900	3.100	0.114	0.122
E1	4.750	5.050	0.187	0.199
L	0.400	0.800	0.016	0.031
$\theta$	0°	6°	0°	6°



● WCSP

