

## Ultra Low-Dropout , Constant-Current White LED Bias

### ■ General Description

The LN5926 is a high performance ultra low- dropout constant current bias supply for white LEDs. It can be used as an alternative to the simple ballast resistors in conventional parallel white LEDs applications. For dimming control, an enable input pin is controlled by processor GPIO output pulses for 16 level linear current. Using a low frequency PWM waveform to this enable input pin also controls the average LED current which is proportional to the PWM duty.

The LN5926 is suitable for single cell Li-ion battery power device that using low forward voltage white LEDs. The white LEDs can be powered directly from battery without extra external components. This takes an advantage of highest efficiency and creates no EMI problem.

### ■ Applications

- Mobile Phones
- MP3
- White LED backlighting
- Camera Flash LED Lighting

### ■ Ordering Information

**LN5926 ①②** (Eg: LN5926QR)

Item	Symbol	Function
①	Q	Denotes Package Type:QFN3×3-16
	D	Denotes Package Type:DFN2×2-8
②	D	Customer requirements
	R	Embossed Tape :Standard Feed
	L	Embossed Tape :Reverse Feed

### ■ Features

- Ultra low 60mV dropout at 20mA
- 3% High accuracy current matching
- 20mA full scale current
- 16 level linear current brightness control
- PWM brightness control
- 2.5V to 5.5V supply voltage range
- Thermal shutdown function
- Under-voltage protection function

### ■ Package

- QFN3×3-16
- DFN2×2-8

## Pin Configuration

### QFN3x3-16

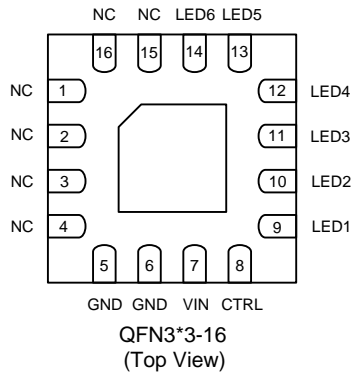

Pin Number	Pin Name	Function
1, 2, 3, 4, 15, 16	N.C.	No connect
5, 6	GND	Ground
7	VIN	Power supply.
8	CTRL	Control pin, can input PWM or pulse signal
9	LED1	LED1 bias current input.
10	LED2	LED2 bias current input.
11	LED3	LED3 bias current input.
12	LED4	LED4 bias current input.
13	LED5	LED5 bias current input.
14	LED6	LED6 bias current input.

### DFN2x2-8

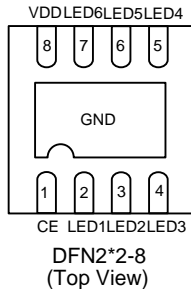

Pin Number	Pin Name	Function
8	VDD	Power supply.
1	CE	Control pin, can input PWM or pulse signal
2	LED1	LED1 bias current input.
3	LED2	LED2 bias current input.
4	LED3	LED3 bias current input.
5	LED4	LED4 bias current input.
6	LED5	LED5 bias current input.
7	LED6	LED6 bias current input.

■ Function Block Diagram

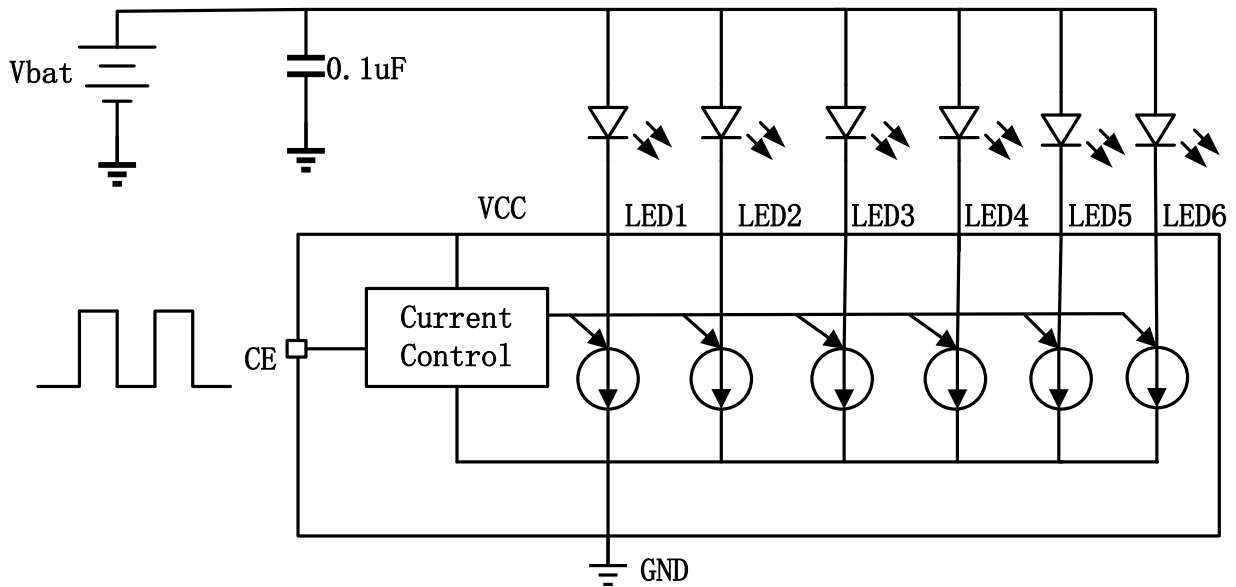

■ Absolute Maximum Ratings

(Ta=25°C)

Item	Symbol	Absolute maximum ratings	Unit
VIN to GND	V <sub>IN</sub>	-0.3~6	V
EN to GND	V <sub>EN</sub>	-0.3~6	V
LEDX to GND	V <sub>LED</sub>	-0.3~6	V
Power Dissipation	P <sub>D</sub>	QFN3×3-16	1000
		DFN2×2-8	1000
Operating Temperature range	T <sub>opr</sub>	-40~+85	°C
Storage Temperature range	T <sub>stg</sub>	-65~+150	
Reflow Temperature (soldering, 10sec)	T <sub>ref</sub>	260	

**Caution:** The absolute maximum ratings are rated values exceeding which the product could suffer physical damage. These values must therefore not be exceeded under any conditions.

## Function Description

LN5926 LED pins act as well matched current source driving LED diode to ground. An EN pin is used to turn on and turn off LN5926. When applying a lower frequency (less than 1kHz) PWM waveform to EN pin, the average LED current will be duty × 20mA (typical). Refer to Fig.1

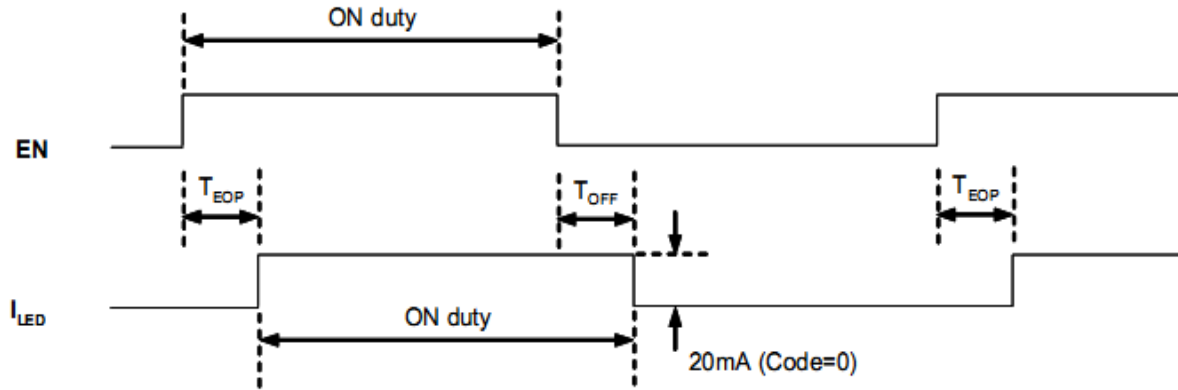
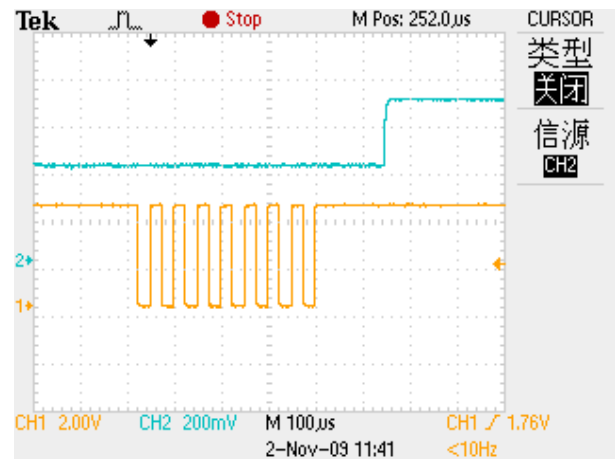
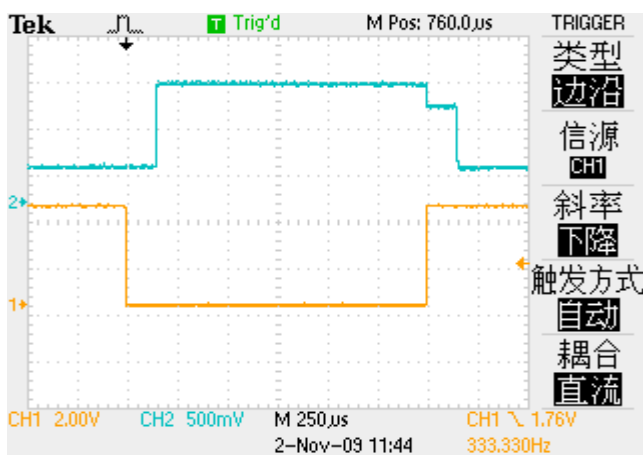

Fig1. Turn On To PWM Dimming

CTRL pin can also input the negative pulse to set the continuous LED current, Suggesting pulse frequency using 25K~ 40K. Input pulse set the current, CTRL pin maintain high level can maintain the brightness. When no initial input pulses, internal registers Set the maximum LED current (CODE = 0), usually 20mA, After inputting N pulses, CTRL maintains high about 120μs, register will be set up to the corresponding N LED current level, usually for  $\frac{16 - N}{16} \times 20 \text{ mA}$ , and reference below chart and typical chart.



**Note:** the yellow as CTRL waveform, Blue is the LED voltage waveform, the below is in the same way.

If the application is not suitable to apply such a low frequency PWM dimming waveform, this EN pin can be negatively pulsed to set continuous LED current. When no negative pulse is input to EN pin (Code=0), the internal register will latched to set the maximum LED current, typically 20mA. Whenever input N negative pulses to the EN pin, it will get a LED current corresponding to Code N. In this manner, LED current will changed from previous value to new value after the last pulse for typical 80μs (TEOP). Please refer to Fig.2

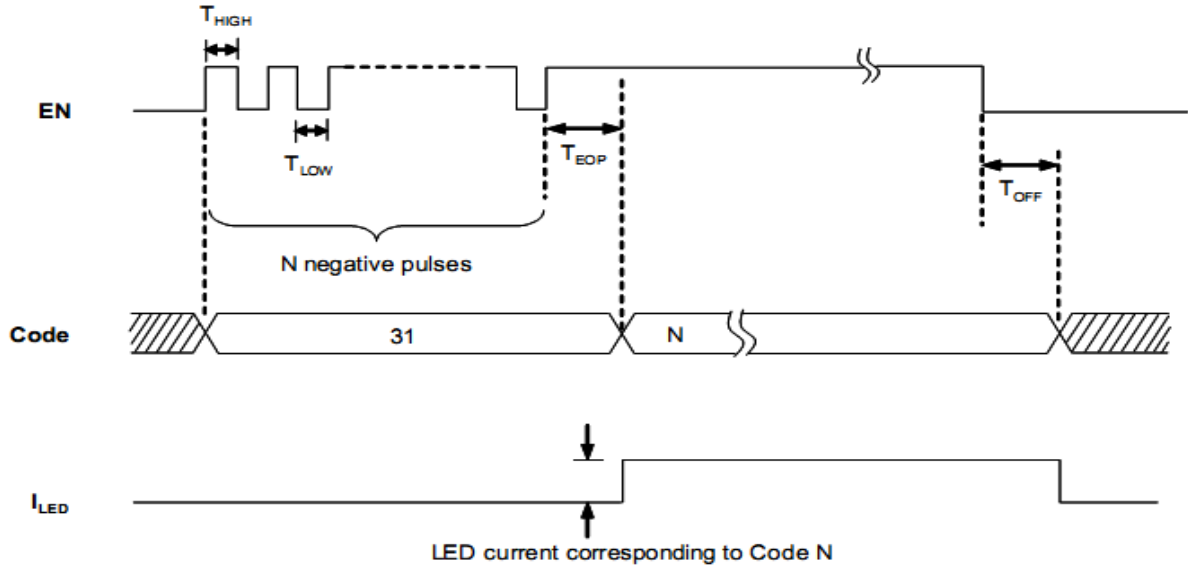
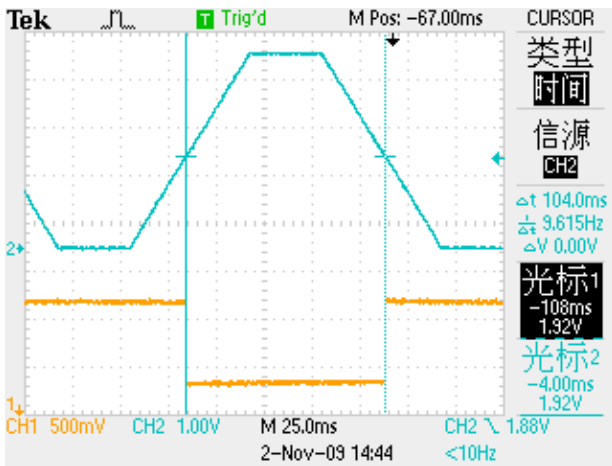
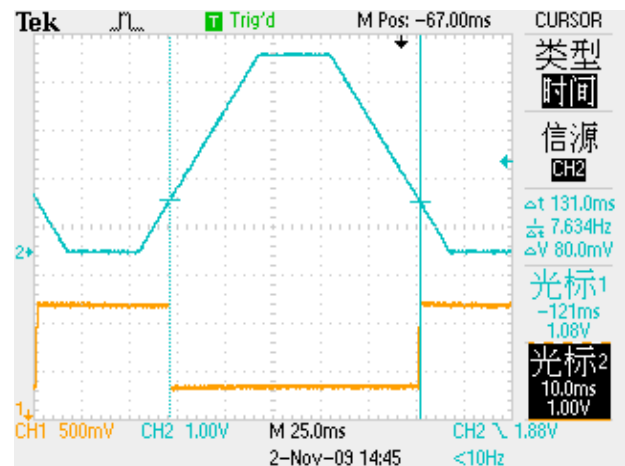

Fig2. Turn On And Config Code N



The effective level waveform about CTRL Pin



Under-Voltage protection waveform

**Note:** once after the input, must ensure that the EN pin keep high level, or setting brightness will change. Maintain a high level of EN after a period of time, the internal counter has cleared, but the latches maintain the LEDs brightness have not unchanged. If you want to adjust current, please input from CODE = 0. The EN pin maintain low-level longer than a certain time  $T_{off}$ , the chip off into save electricity mode.

Above current and code corresponding relation is a design, individual differences between the different temperature, voltage and current inaccurate will lead to the Current is not accurate. Please use the actual measurement results.

■ Typical Application Circuit

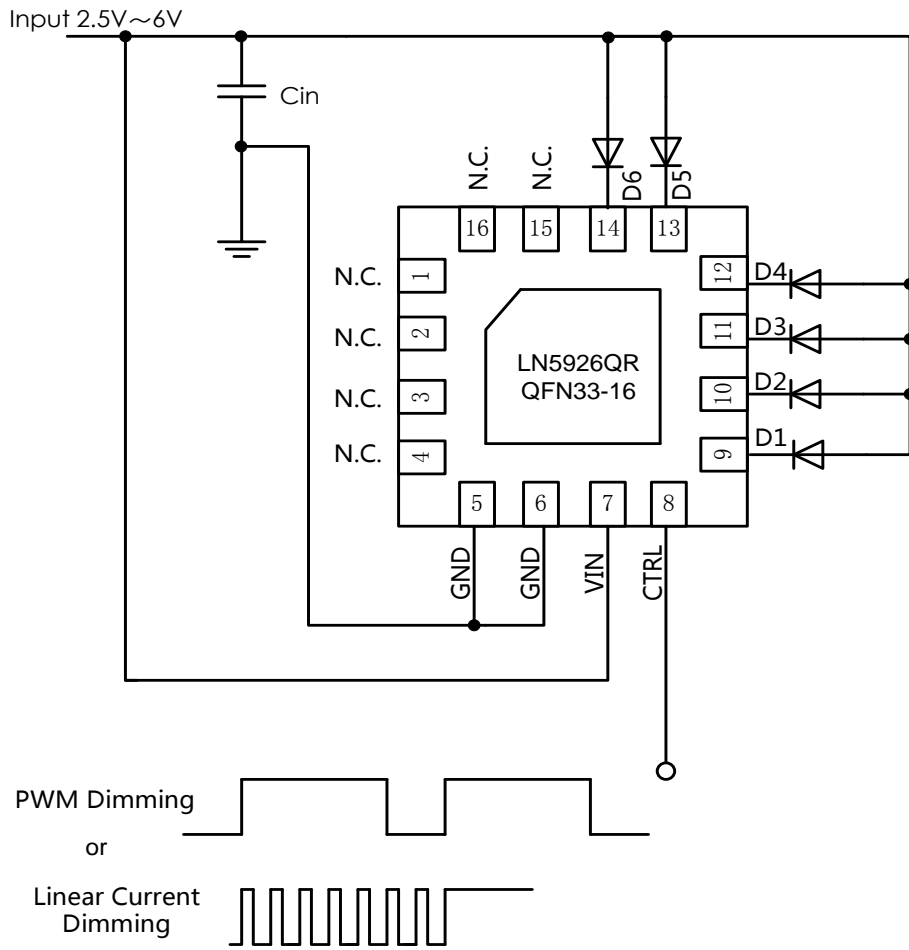

## ■ Electrical Characteristics

V<sub>IN</sub>= 3.6V, EN=3.6V

(T<sub>a</sub>=25°C, unless otherwise noted)

Parameter	Symbol	Test Condition	Min.	Typ.	Max.	Units
Input Supply Voltage	V <sub>IN</sub>		2.5		5.5	V
Undervoltage Lockout Threshold	V <sub>UVLO</sub>		-	2.1	-	V
Current into LEDX	I <sub>LED</sub>	MAX I <sub>LED</sub>	18	20	22	mA
Shutdown Current	I <sub>SHDN</sub>	V <sub>IN</sub> =5V, EN=0V	-1	-	+1	μA
Quiescent Current	I <sub>Q</sub>		-	500	-	μA
LED Pin Voltage Dropout	V <sub>LED-DROP</sub>	V <sub>LED(DROP)</sub> , 90% Max I <sub>LED</sub>		60	80	mV
Output Current Line Regulation	I <sub>LED-LINEAR</sub>	V <sub>LED</sub> = 0.5V~2V	-1	-	+1	%/V
Current Matching	I <sub>LED-LED-ERR</sub>	2mA<I <sub>LED</sub> <20mA	-3	-	+3	%
Thermal Shutdown Threshold				150		°C
EN Pin Input Voltage High	V <sub>IH</sub>		1.2	-	-	V
EN Pin Input Voltage Low	V <sub>IL</sub>		-	-	0.8	V
EN Pin Input Current	I <sub>EN</sub>		-1	-	+1	μA
EN Pin Off Timeout	T <sub>OFF</sub>		40	120	200	μS
EN Pin End of Pulse Timeout	T <sub>EOP</sub>		40	120	200	μS
EN Pin Pulse High Time	T <sub>HIGH</sub>		5	-	30	μS
EN Pin Pulse Low Time	T <sub>LOW</sub>		5	-	30	μS

■ Package Information

- QFN3×3-16

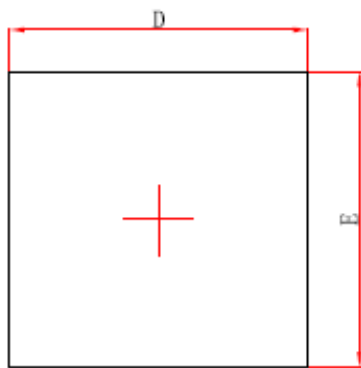

Top View

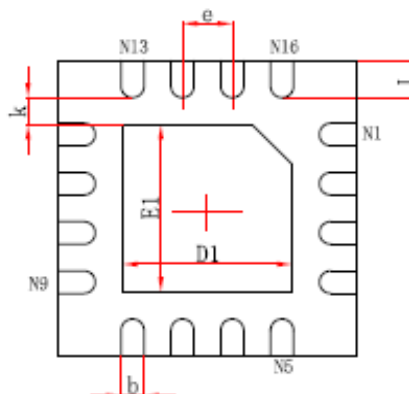

Bottom View

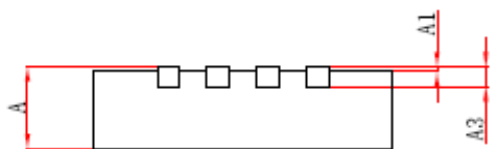

Side View

Symbol	Dimensions In Millimeters		Dimensions In Inches	
	Min.	Max.	Min.	Max.
A	0.700/0.800	0.800/0.900	0.028/0.031	0.031/0.035
A1	0.000	0.050	0.000	0.002
A3	0.203REF.		0.008REF.	
D	2.900	3.100	0.114	0.122
E	2.900	3.100	0.114	0.122
D1	1.600	1.800	0.063	0.071
E1	1.600	1.800	0.063	0.071
k	0.200MIN.		0.008MIN.	
b	0.180	0.300	0.007	0.012
e	0.500TYP.		0.020TYP.	
L	0.300	0.500	0.012	0.020



• DFN2×2-8

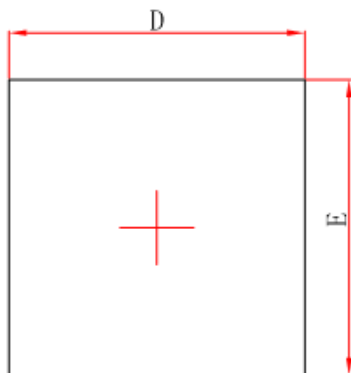

Top View

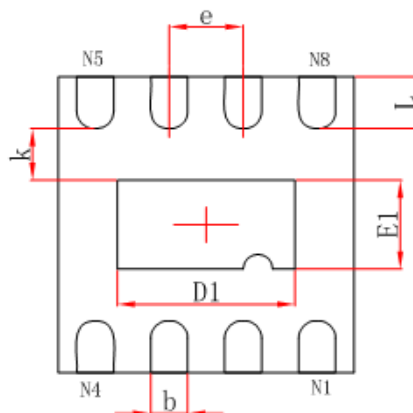

Bottom View

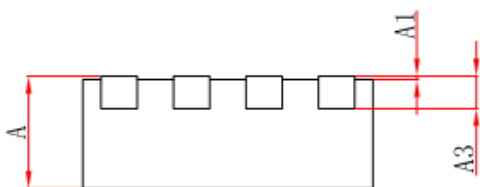

Side View

Symbol	Dimensions In Millimeters		Dimensions In Inches	
	Min.	Max.	Min.	Max.
A	0.700/0.800	0.800/0.900	0.028/0.031	0.031/0.035
A1	0.000	0.050	0.000	0.002
A3	0.203REF.		0.008REF.	
D	1.900	2.100	0.075	0.083
E	1.900	2.100	0.075	0.083
D1	1.100	1.300	0.043	0.051
E1	0.500	0.700	0.020	0.028
k	0.200MIN.		0.008MIN.	
b	0.180	0.300	0.007	0.012
e	0.500TYP.		0.020TYP.	
L	0.250	0.450	0.010	0.018