

3W Stereo Audio Power Amplifier With Advanced DC Volume Control

General Description

The LN6011 is a stereo audio power amplifier that drives 3 W/channel of continuous RMS power into a 3Ω load. Advanced DC volume control minimizes external components and allows BTL (speaker) volume control and SE (headphone) volume control. Notebook and pocket PCs benefit from the integrated feature set that minimizes external components without sacrificing functionality.

To simplify design, the speaker volume level is adjusted by applying a DC voltage to the VOLUME terminal. Likewise, the delta between speaker volume and headphone volume can be adjusted by applying a DC voltage to the SEDIFF terminal. To avoid an unexpected high volume level through the headphones, a third terminal, SEMAX, limits the headphone volume level when a DC voltage is applied. Finally, to ensure a smooth transition between active and shutdown modes, a fade mode ramps the volume up and down.

Typical Application Circuit

- Typical LN6011 application circuit using single-ended inputs and input MUX

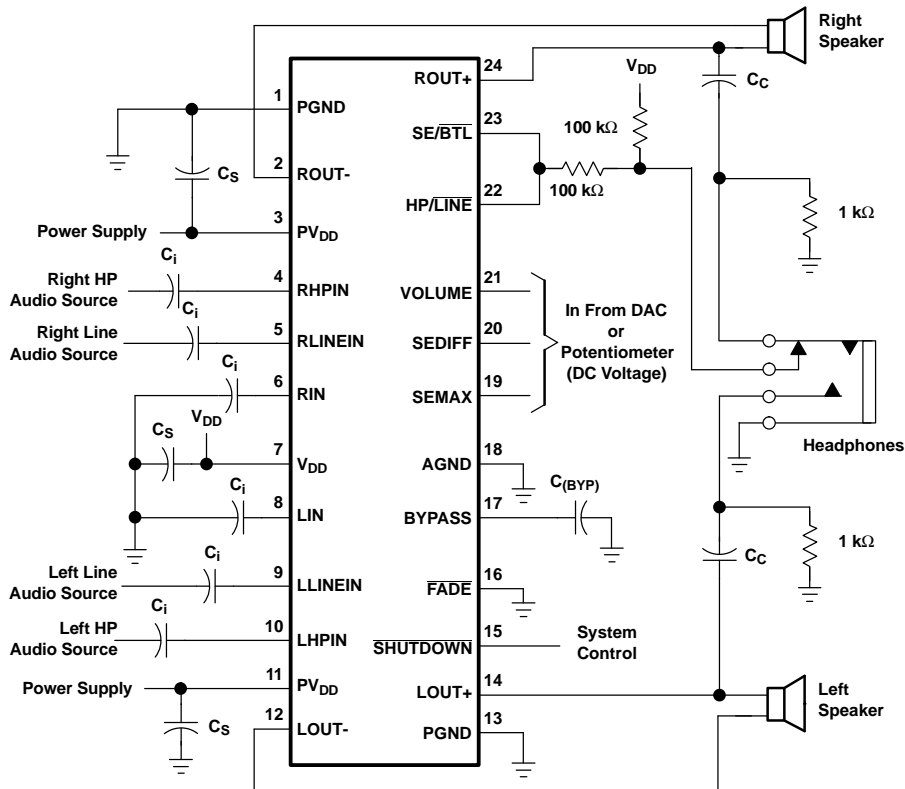

Figure 1.

Applications

- Notebook PC
- LCD Monitors
- Pocket PC

Features

- Advanced DC Volume Control With 2-dB Steps, From -40 dB to 20 dB
 - Fade Mode
 - Maximum Volume Setting for SE Mode
 - Adjustable SE Volume Control
- Referenced to BTL Volume Control
- 3 W Into 3Ω Speakers
- Stereo Input MUX
- Differential Inputs

Package

- TSSOP-24/PP

NOTE: 0.1 μ F ceramic capacitor should be placed as close as possible to the IC. For filtering lower-frequency noise signals, a larger electrolytic capacitor of 10 μ F or greater should be placed near the audio power amplifier.

● **Typical LN6011 application circuit using differential inputs**

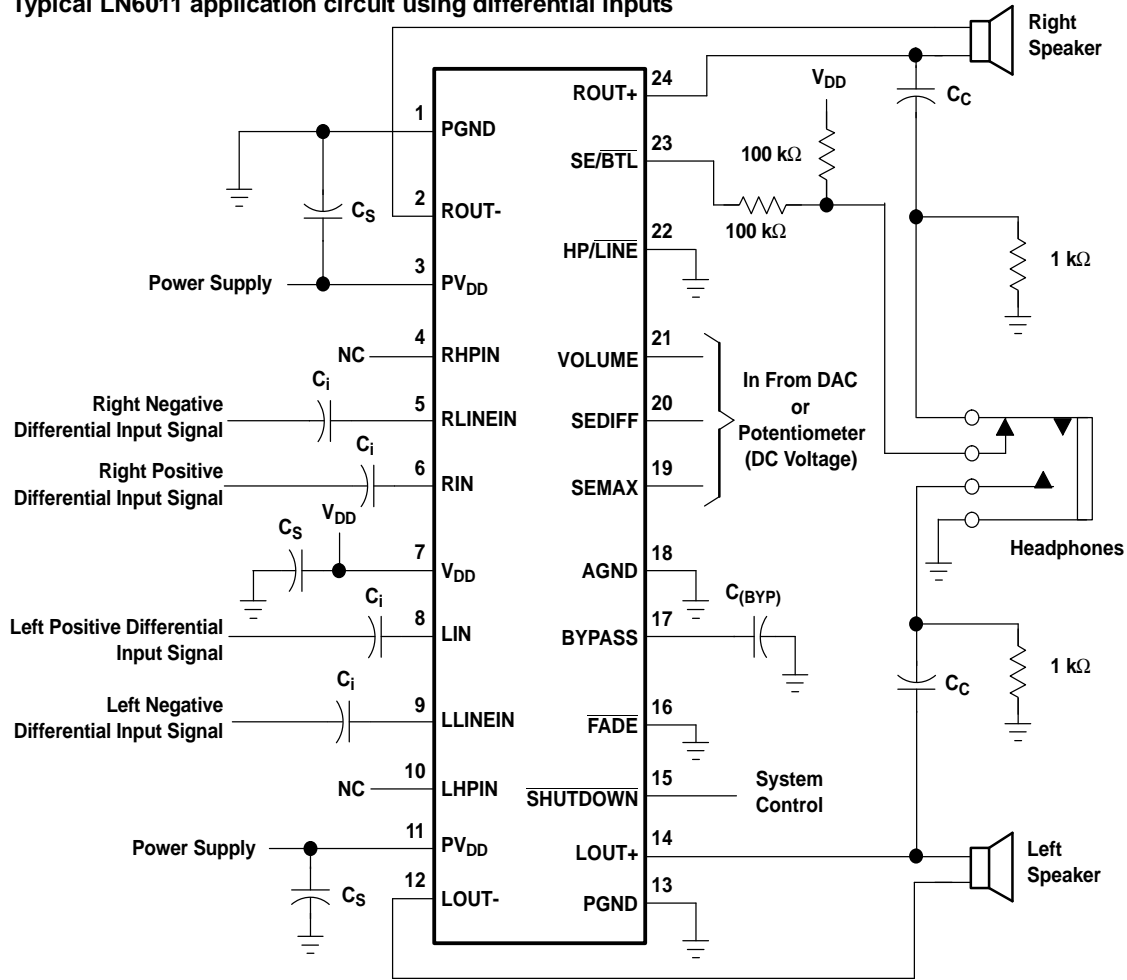
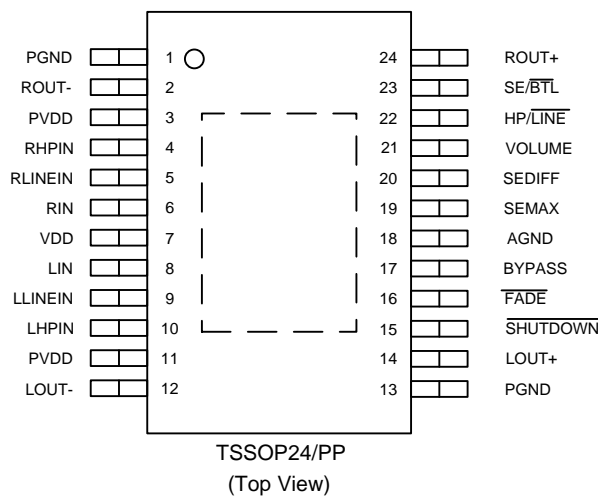

Figure2.

NOTE: 0.1 μ F ceramic capacitor should be placed as close as possible to the IC. For filtering lower-frequency noise signals, a larger electrolytic capacitor of 10 μ F or greater should be placed near the audio power amplifier.

■ **Pin Configuration**



Pin Function Description

Pin Name	No.	I/O	Function Description
PGND	1,13	-	Power ground
LOUT-	12	O	Left channel negative audio output
PV _{DD}	3,11	-	Supply voltage terminal for power stage
LHPIN	10	I	Left channel headphone input,selected when HP/ $\overline{\text{LINE}}$ is held high
LLINEIN	9	I	Left channel line input,selected when HP/ $\overline{\text{LINE}}$ is held low
LIN	8	I	Common left channel input for fully differential input. AC ground for single-ended inputs.
V _{DD}	7	-	Supply voltage terminal
RIN	6	I	Common right channel input for fully differential input. AC ground for single-ended inputs.
RLINEIN	5	I	Right channel line input, selected when HP/ $\overline{\text{LINE}}$ is held low
RHPIN	4	I	Right channel headphone input, selected when HP/ $\overline{\text{LINE}}$ is held high
ROUT-	2	O	Right channel negative audio output
OUT+	14	O	Right channel positive audio output
$\overline{\text{SHUTDOWN}}$	15	I	Places the amplifier in shutdown mode if a TTL logic low is placed on this terminal
$\overline{\text{FADE}}$	16	I	Places the amplifier in fade mode if a logic low is placed on this terminal; normal operation if a logic hplaced on this terminal
BYPASS	17	I	Tap to voltage divider for internal midsupply bias generator used for analog reference
AGND	18	-	Analog power supply ground
SEMAX	19	I	Sets the maximum volume for single ended operation. DC voltage range is 0 to VDD .
SEDIFF	20	I	Sets the difference between BTL volume and SE volume. DC voltage range is 0 to VDD .
VOLUME	21	I	Terminal for dc volume control. DC voltage range is 0 to VDD .
HP/ $\overline{\text{LINE}}$	22	I	Input MUX control. When logic high, RHPIN and LHPIN inputs are selected. When logic low, RLINEIN and LLINEIN inputs are selected.
SE/ $\overline{\text{BTL}}$	23	I	Output MUX control. When this terminal is high, SE outputs are selected. When this terminal is low, BTL outputs are selected
LOUT+	14	O	Left channel positive audio output
ROUT+	24	O	Right channel positive audio output
$\overline{\text{SHUTDOWN}}$	15	I	Places the amplifier in shutdown mode if a TTL logic low is placed on this terminal
$\overline{\text{FADE}}$	16	I	Places the amplifier in fade mode if a logic low is placed on this terminal; normal operation if a logic h placed on this terminal

■ Function Block Diagram

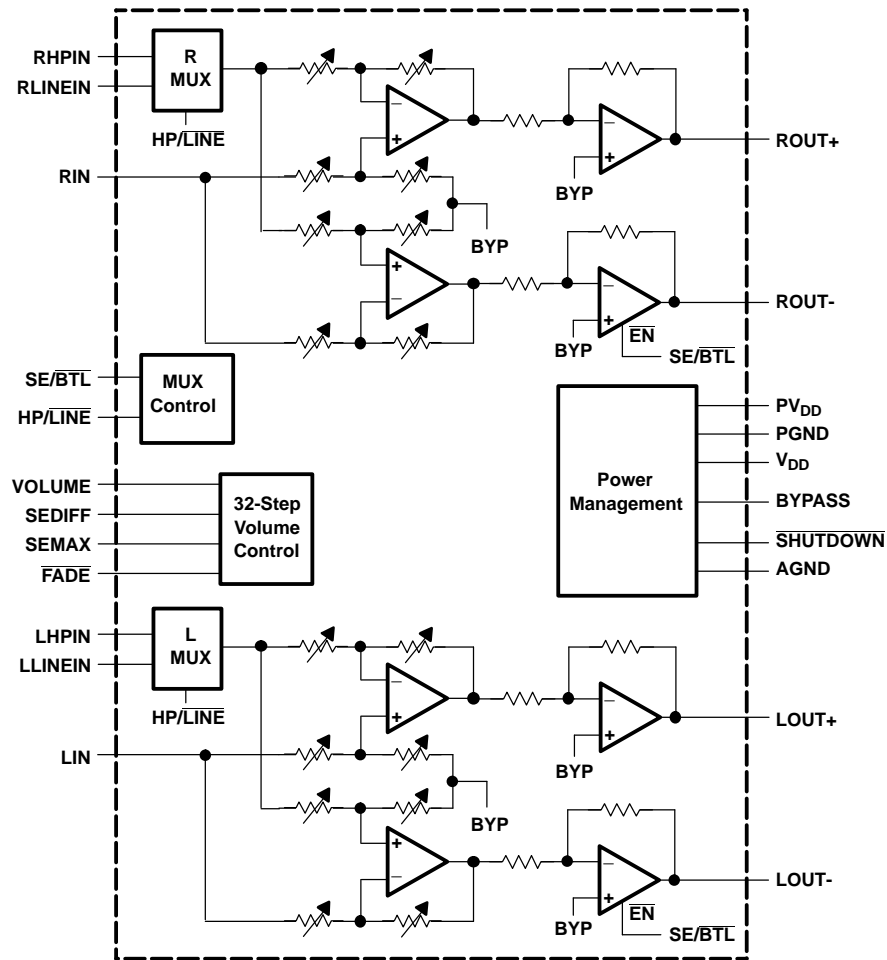

■ Absolute Maximum Ratings

Parameter	Symbol	Value	Unit
Supply Voltage	V_{DD}	-0.3—6.0	V
Input Voltage	V_{IN}	-0.3— $V_{DD}+0.3$	V
Operating Temperature	T_A	-40—85	°C
Junction Temperature	—	-45—150	°C
Storage Temperature	T_{stg}	-65—150	°C
ESD Susceptibility	-	2000	V

■ Electrical Characteristics

(VDD = 5V Unless otherwise specified. Limits apply for TA = 25°C.)

Symbol	Parameters	Test Conditions	Min.	Typ.	Max.	Unit
V _{OO}	Output Offset Voltage	V _{DD} =5.5V, Gain=0dB, SE/ $\overline{\text{BTL}}$ =0V			30	mV
		V _{DD} =5.5V, Gain=20dB, SE/ $\overline{\text{BTL}}$ =0V			50	
PSRR	Power Supply Rejection Ratio	V _{DD} =PV _{DD} =4.0V to 5.5V	-42	-70		dB
I _{IH}	High-level input current	V _{DD} =PV _{DD} =5.5V, V _I =V _{DD} =PV _{DD}			1	μA
I _{IL}	Low-level input current	V _{DD} =PV _{DD} =5.5V, V _I =0V			1	μA
I _(SD)	Shutdown Current	$\overline{\text{SHUTDOWN}}$ =0V		1	20	μA
I _{DD}	Supply current, no load	V _{DD} =PV _{DD} =5.5V, SE/ $\overline{\text{BTL}}$ =0V, $\overline{\text{SHUTDOWN}}$ =2V	6.0	7.5	9.0	mA
		V _{DD} =PV _{DD} =5.5V, SE/ $\overline{\text{BTL}}$ =5.5V, $\overline{\text{SHUTDOWN}}$ =2V	3.0	5	6	mA
I _{DD}	Supply current, max power into a 3Ω load	V _{DD} =PV _{DD} =5.5V, SE/ $\overline{\text{BTL}}$ =0V V $\overline{\text{SHUTDOWN}}$ =2V, R _L =3Ω		1.5		ARms

■ Operating Characteristics

(VDD = 5V , GAIN=2V/V, RL=8Ω, Unless otherwise specified. Limits apply for TA = 25°C.)

Symbol	Parameters	Test Conditions	Min.	Typ.	Max.	Unit
P _O	Output Power	THD =1%, f =1kHz		2		W
		THD =10%, f =1kHz, VDD = 5.5 V		3		
THD+N	Total Harmonic Distortion+Noise	P _O =1W, R _L =8Ω, f=20Hz to 20kHz		<0.4%		
V _{OH}	High-level Output voltage	R _L =8Ω, Measured between output and V _{DD}			700	mV
V _{OL}	Low-level Output voltage	R _L =8Ω , Measured between output and GND			400	mV

● Table 1: DC volume control corresponding to the table (BTL output mode $V_{DD} = 5V$)⁽¹⁾

VOLUME (PIN5)		GAIN OF AMPLIFIER (Typ)
FROM (V)	TO (V)	
0.00	0.26	-85 ⁽²⁾
0.33	0.37	-40
0.44	0.48	-38
0.56	0.59	-36
0.67	0.70	-34
0.78	0.82	-32
0.89	0.93	-30
1.01	1.04	-28
1.12	1.16	-26
1.23	1.27	-24
1.35	1.38	-22
1.46	1.49	-20
1.57	1.60	-18
1.68	1.72	-16
1.79	1.83	-14
1.91	1.94	-12
2.02	2.06	-10
2.13	2.17	-8
2.25	2.28	-6 ⁽²⁾
2.36	2.39	-4
2.47	2.50	-2
2.58	2.61	0
2.70	2.73	2
2.81	2.83	4
2.92	2.95	6
3.04	3.06	8
3.15	3.17	10
3.26	3.29	12
3.38	3.40	14
3.49	3.51	16
3.60	3.63	18
3.71	5.00	20 ⁽²⁾

(1) For other values of V_{DD} , scale the voltage values in the table by a factor of $V_{DD}/5$.

(2) Tested in production. Remaining gain steps are specified by design.

● Table 2 :DC volume control corresponding to the table (SE output mode $V_{DD} = 5V$)⁽¹⁾

SE_VOLUME=VOLUME or SEMAX		GAIN OF AMPLIFIER (Typ)
FROM (V)	TO (V)	
0.00	0.26	-85 ⁽²⁾
0.33	0.37	-40
0.44	0.48	-38
0.56	0.59	-36
0.67	0.70	-34
0.78	0.82	-32
0.89	0.93	-30
1.01	1.04	-28
1.12	1.16	-26
1.23	1.27	-24
1.35	1.38	-22
1.46	1.49	-20
1.57	1.60	-18
1.68	1.72	-16
1.79	1.83	-14
1.91	1.94	-12
2.02	2.06	-10
2.13	2.17	-8
2.25	2.28	-6 ⁽²⁾
2.36	2.39	-4
2.47	2.50	-2
2.58	2.61	0 ⁽²⁾
2.70	2.73	2
2.81	2.83	4
2.92	2.95	6 ⁽²⁾
3.04	3.06	8
3.15	3.17	10
3.26	3.29	12
3.38	3.40	14
3.49	3.51	16
3.60	3.63	18
3.71	5.00	20

(1) For other values of V_{DD} , scale the voltage values in the table by a factor of $V_{DD} / 5$.

(2) Tested in production. Remaining gain steps are specified by design.

Application Information

SE/BTL OPERATION

The ability of the LN6011 to easily switch between BTL and SE modes is one of its most important cost saving features. This feature eliminates the requirement for an additional headphone amplifier in applications where internal stereo speakers are driven in BTL mode but external headphone or speakers must be accommodated. Internal to the LN6011, two separate amplifiers drive OUT+ and OUT-. The SE/ $\overline{\text{BTL}}$ input controls the operation of the follower amplifier that drives LOUT- and ROUT-. When SE/ $\overline{\text{BTL}}$ is held low, the amplifier is on and the LN6011 is in the BTL mode. When SE/ $\overline{\text{BTL}}$ is held high, the OUT- amplifiers are in a high output impedance state, which configures the LN6011 as an SE driver from LOUT+ and ROUT+.

I_{DD} is reduced by approximately one-third in SE mode. Control of the SE/ $\overline{\text{BTL}}$ input can be from a logic-level CMOS source or, more typically, from a resistor divider network as shown in the Figure below. The trip level for the SE/ $\overline{\text{BTL}}$ input can be found in the recommended operating conditions table.

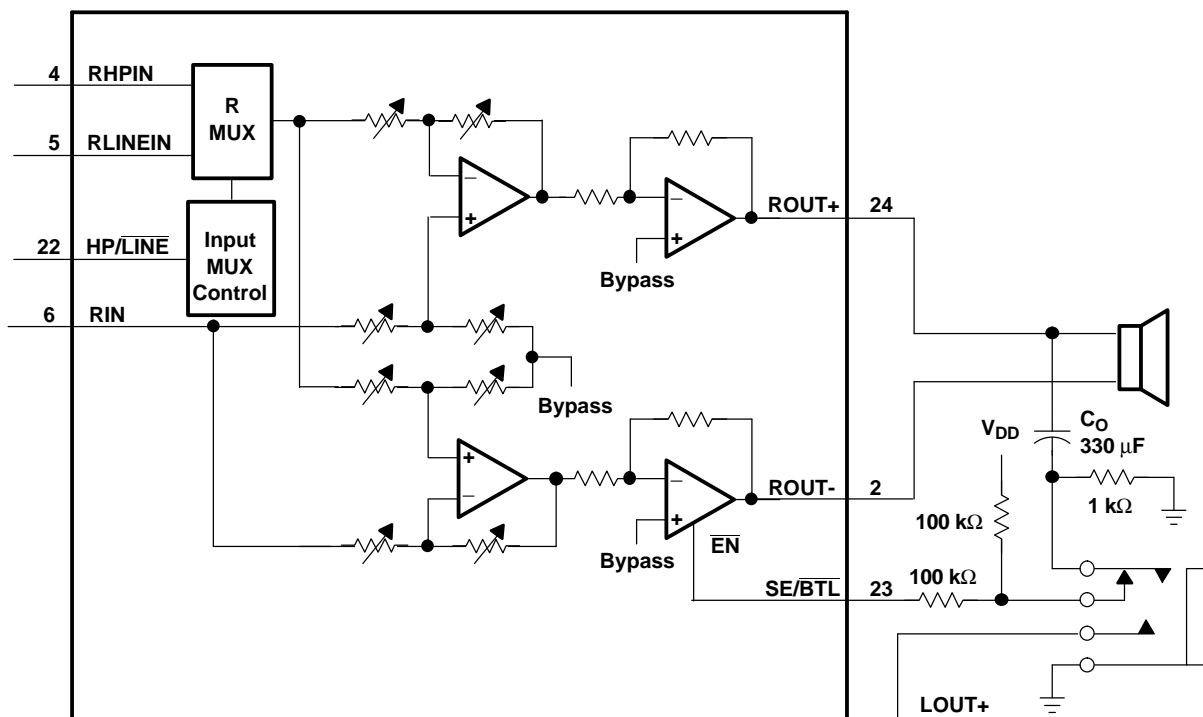

Figure 3. LN6011 Resistor Divider Network Circuit

Using a 1/8-in. (3,5 mm) stereo headphone jack, the control switch is closed when no plug is inserted. When closed the 100k Ω /1k Ω divider pulls the SE/ $\overline{\text{BTL}}$ input low. When a plug is inserted, the 1k Ω resistor is disconnected and the SE/ $\overline{\text{BTL}}$ input is pulled high. When the input goes high, the OUT- amplifier is shut down causing the speaker to mute (open-circuits the speaker). The OUT+ amplifier then drives through the output capacitor (C_o) into the headphone jack.

HP/LINE OPERATION

The HP/ $\overline{\text{LINE}}$ input controls the internal input multiplexer (MUX). Refer to the block diagram in Figure 3. This allows the device to switch between two separate stereo inputs to the amplifier. For design flexibility, the HP/ $\overline{\text{LINE}}$ control is independent of the output mode, SE or BTL, which is controlled by the aforementioned SE/ $\overline{\text{BTL}}$ pin. To allow the amplifier to switch from the LINE inputs to the HP inputs when the output switches from BTL mode to SE mode, simply connect the SE/ $\overline{\text{BTL}}$ control input to the

HP / $\overline{\text{LINE}}$ input.

When this input is logic high, the RHPIN and LHPIN inputs are selected. When this terminal is logic low, the RLINEIN and LLINEIN inputs are selected. This operation is also detailed in Table 1 and the trip levels for a logic low (V_{IL}) or logic high (V_{IH}) can be found in the recommended operating conditions table.

● SHUTDOWN MODES

The LN6011 employs a shutdown mode of operation designed to reduce supply current (I_{DD}) to the absolute minimum level during periods of nonuse for battery-power conservation. The $\overline{\text{SHUTDOWN}}$ input terminal should be held high during normal operation when the amplifier is in use. Pulling $\overline{\text{SHUTDOWN}}$ low causes the outputs to mute and the amplifier to enter a low-current state, $I_{DD} = 20\mu\text{A}$. $\overline{\text{SHUTDOWN}}$ should never be left unconnected because amplifier operation would be unpredictable.

Table 3. HP / $\overline{\text{LINE}}$, SE / $\overline{\text{BTL}}$, and Shutdown Functions

INPUT ⁽¹⁾			AMPLIFIER STATE	
HP / $\overline{\text{LINE}}$	SE / $\overline{\text{BTL}}$	$\overline{\text{SHUTDOWN}}$	INPUT	OUTPUT
X	X	Low	X	Mute
Low	Low	High	Line	BTL
Low	High	High	Line	SE
High	Low	High	HP	BTL
High	High	High	HP	SE

(1) Inputs should never be left unconnected.

● FADE OPERATION

For design flexibility, a fade mode is provided to slowly ramp up the amplifier gain when coming out of shutdown mode and conversely ramp the gain down when going into shutdown. This mode provides a smooth transition between the active and shutdown states and virtually eliminates any pops or clicks on the outputs.

When the $\overline{\text{FADE}}$ input is a logic low, the device is placed into fade-on mode. A logic high on this pin places the amplifier in the fade-off mode. The voltage trip levels for a logic low (V_{IL}) or logic high (V_{IH}) can be found in the recommended operating conditions table.

When a logic low is applied to the $\overline{\text{FADE}}$ pin and a logic low is then applied on the $\overline{\text{SHUTDOWN}}$ pin, the channel gain steps down from gain step to gain step at a rate of two clock cycles per step. With a nominal internal clock frequency of 58 Hz, this equates to 34ms (1/24 Hz) per step. The gain steps down until the lowest gain step is reached. The time it takes to reach this step depends on the gain setting prior to placing the device in shutdown. For example, if the amplifier is in the highest gain mode of 20 dB, the time it takes to ramp down the channel gain is 1.05 seconds. This number is calculated by taking the number of steps to reach the lowest gain from the highest gain, or 31 steps, and multiplying by the time per step, or 34ms.

After the channel gain is stepped down to the lowest gain, the amplifier begins discharging the bypass capacitor from the nominal voltage of $V_{DD}/2$ to ground. This time is dependent on the value of the bypass capacitor. For a 0.47 μF capacitor that is used in the application diagram in Figure 1, the time is approximately 500 ms. This time scales linearly with the value of bypass capacitor. For example, if a 1 μF capacitor is used for bypass, the time period to discharge the capacitor to ground is twice that of the 0.47 μF capacitor, or 1 second. Figure 3 below is a waveform captured at the output during the shutdown sequence when the part is in fade-on mode. The gain is set to the highest level and the output is at V_{DD} when the amplifier is shut down.

When a logic high is placed on the SHUTDOWN pin and the FADE pin is still held low, the device begins the start-up process. The bypass capacitor will begin charging. Once the bypass voltage reaches the final value of $V_{DD}/2$, the gain increases in 2dB steps from the lowest gain level to the gain level set by the dc voltage applied to the VOLUME, SEDIFF, and SEMAX pins.

In the fade-off mode, the amplifier stores the gain value prior to starting the shutdown sequence. The output of the amplifier immediately drops to $V_{DD}/2$ and the bypass capacitor begins a smooth discharge to ground. When shutdown is released, the bypass capacitor charges up to $V_{DD}/2$ and the channel gain returns immediately to the value stored in memory. Figure 4 below is a waveform captured at the output during the shutdown sequence when the part is in the fade-off mode. The gain is set to the highest level, and the output is at V_{DD} when the amplifier is shut down.

The power-up sequence is different from the shutdown sequence and the voltage on the FADE pin does not change the power-up sequence. Upon a power-up condition, the LN6011 begins in the lowest gain setting and steps up 2dB every 2 clock cycles until the final value is reached as determined by the dc voltage applied to the VOLUME, SEDIFF, and SEMAX pins.

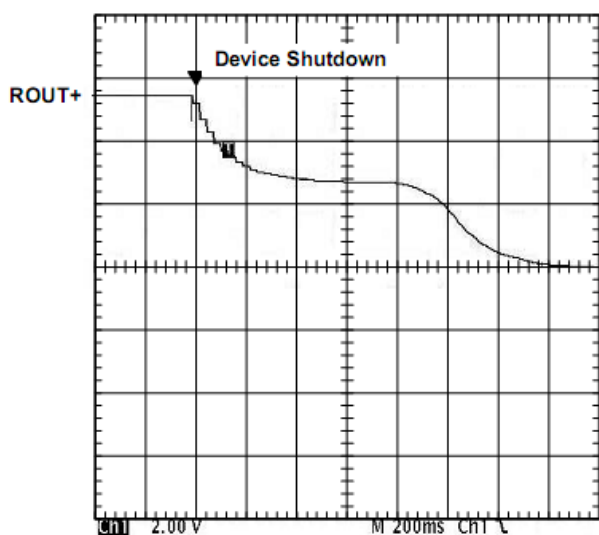

Figure 4. Shutdown Sequence in the Fade-on Mode

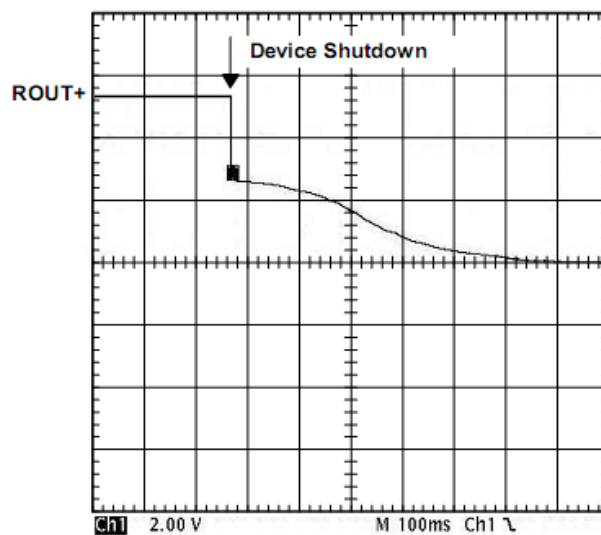

Figure 5. Shutdown Sequence in the Fade-off Mode

● VOLUME, SEDIFF, AND SEMAX OPERATION

Three pins labeled VOLUME, SEDIFF, and SEMAX control the BTL volume when driving speakers and the SE volume when driving headphones. All of these pins are controlled with a dc voltage, which should not exceed V_{DD} .

When driving speakers in BTL mode, the VOLUME pin is the only pin that controls the gain. Table 1 shows the gain for the BTL mode. The voltages listed in the table are for $V_{DD} = 5$ V. For a different V_{DD} , the values in the table scale linearly. If $V_{DD} = 4$ V, multiply all the voltages in the table by $4V/5$ V, or 0.8.

The LN6011 allows the user to specify a difference between BTL gain and SE gain. This is desirable to avoid any listening discomfort when plugging in headphones. When switching to SE mode, the SEDIFF and SEMAX pins control the single-ended gain proportional to the gain set by the voltage on the VOLUME pin. When SEDIFF = 0V, the difference between the BTL gain and the SE gain is 6 dB. Refer to the section labeled bridged-tied load versus single-ended load for an explanation on why the gain in BTL mode is 2x that of single-ended mode, or 6dB greater. As the voltage on the SEDIFF terminal is increased, the gain in SE mode decreases. The voltage on the SEDIFF terminal is subtracted from the voltage on the VOLUME terminal and this value is used to determine the SE gain.

Some audio systems require that the gain be limited in the single-ended mode to a level that is comfortable for headphone

listening. Most volume control devices only have one terminal for setting the gain. For example, if the speaker gain is 20dB, the gain in the headphone channel is fixed at 14dB. This level of gain could cause discomfort to listeners and the SEMAX pin allows the designer to limit this discomfort when plugging in headphones. The SEMAX terminal controls the maximum gain for single-ended mode.

The functionality of the SEDIFF and SEMAX pin are combined to set the SE gain. A block diagram of the combined functionality is shown in Figure 6. The value obtained from the block diagram for SE_VOLUME is a dc voltage that can be used in conjunction with Table 2 to determine the SE gain. Again, the voltages listed in the table are for $V_{DD} = 5\text{ V}$. The values must be scaled for other values of V_{DD} .

Table 1 and Table 2 show a range of voltages for each gain step. There is a gap in the voltage between each gain step. This gap represents the hysteresis about each trip point in the internal comparator. The hysteresis ensures that the gain control is monotonic and does not oscillate from one gain step to another. If a potentiometer is used to adjust the voltage on the control terminals, the gain increases as the potentiometer is turned in one direction and decreases as it is turned back the other direction. The trip point, where the gain actually changes, is different depending on whether the voltage is increased or decreased as a result of the hysteresis about each trip point. The gaps in Table 1 and Table 2 can also be thought of as indeterminate states where the gain could be in the next higher gain step or the lower gain step depending on the direction the voltage is changing. If using a DAC to control the volume, set the voltage in the middle of each range to ensure that the desired gain is achieved.

A pictorial representation of the volume control can be found in Figure 7. The graph focuses on three gain steps with the trip points defined in Table 1 for BTL gain. The dotted line represents the hysteresis about each gain step.

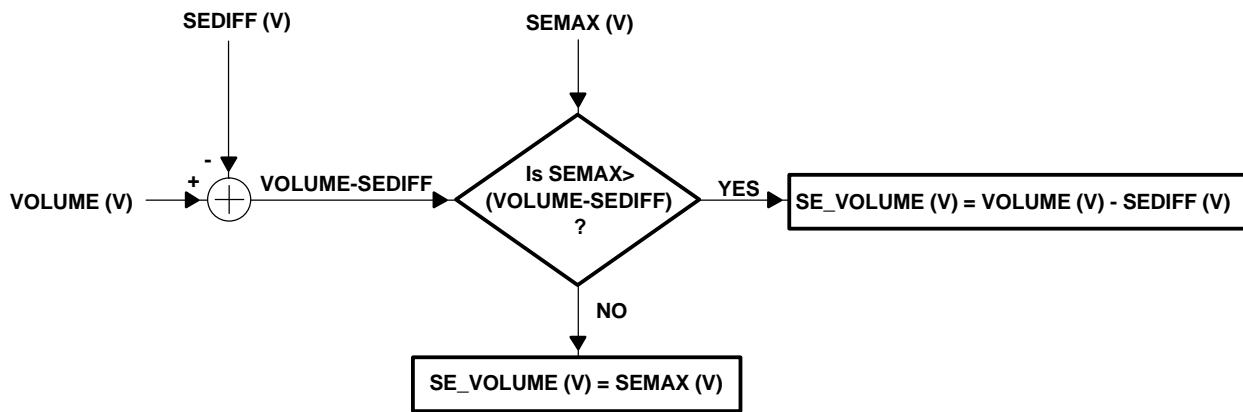

Figure 6. Block Diagram of SE Volume Control

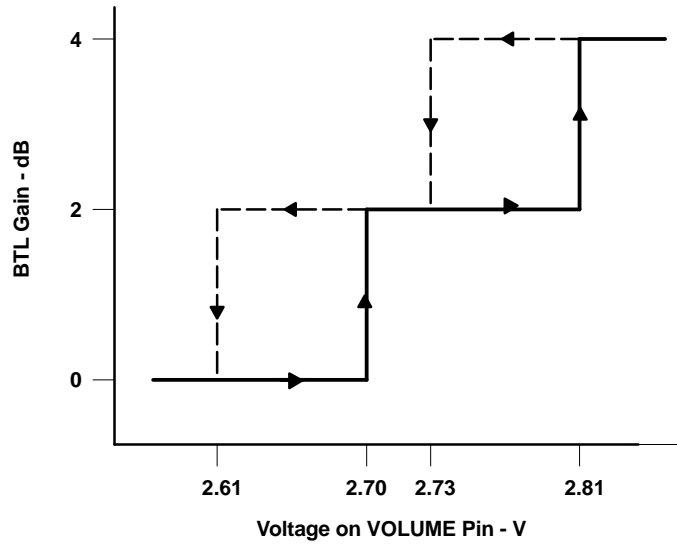

Figure 7. DC Volume Control Operation

● INPUT RESISTANCE

Each gain setting is achieved by varying the input resistance of the amplifier, which can range from its smallest value to over six times that value. As a result, if a single capacitor is used in the input high-pass filter, the -3dB or cutoff frequency also changes by over six times.

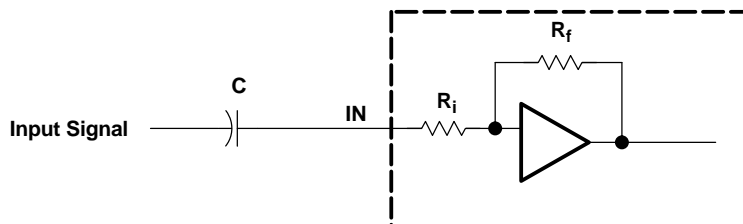

Figure 8. Resistor on Input for Cut-Off Frequency

The -3dB frequency can be calculated using Equation 1 .

$$f_{-3dB} = \frac{1}{2\pi CR_i}$$

● **INPUT CAPACITOR, C_i**

In the typical application an input capacitor (C_i) is required to allow the amplifier to bias the input signal to the proper dc level for optimum operation. In this case, C_i and the input impedance of the amplifier (R_i) form a high-pass filter with the corner frequency determined in Equation 2 .

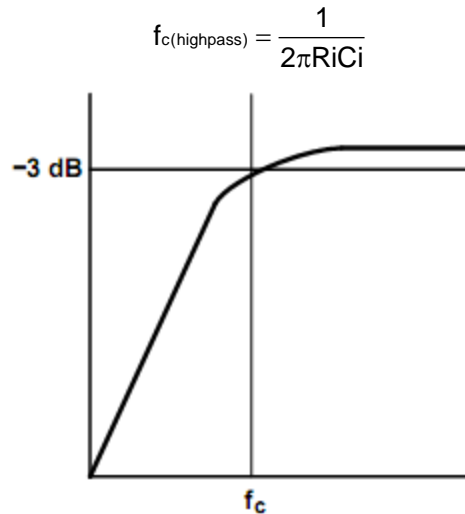

The value of C_i is important to consider as it directly affects the bass (low frequency) performance of the circuit. Consider the example where R_i is 70 k Ω and the specification calls for a flat-bass response down to 40Hz. Equation 2 is reconfigured as Equation 3 .

$$C_i = \frac{1}{2\pi R_i f_c}$$

In this example, C_i is 56.8 nF, so one would likely choose a value in the range of 56nF to 1 μ F. A further consideration for this capacitor is the leakage path from the input source through the input network (C_i) and the feedback network to the load. This leakage current creates a dc offset voltage at the input to the amplifier that reduces useful headroom, especially in high gain applications. For this reason, a low-leakage tantalum or ceramic capacitor is the best choice. When polarized capacitors are used, the positive side of the capacitor should face the amplifier input in most applications as the dc level there is held at $V_{DD} / 2$, which is likely higher than the source dc level. Note that it is important to confirm the capacitor polarity in the application.

● **POWER SUPPLY DECOUPLING, $C_{(S)}$**

The LN6011 is a high-performance CMOS audio amplifier that requires adequate power supply decoupling to ensure the output total harmonic distortion (THD) is as low as possible. Power supply decoupling also prevents oscillations for long lead lengths between the amplifier and the speaker. The optimum decoupling is achieved by using two capacitors of different types that target different types of noise on the power supply leads. For higher frequency transients, spikes, or digital hash on the line, a good low equivalent-series-resistance (ESR) ceramic capacitor, typically 0.1 μ F placed as close as possible to the device V_{DD} lead, works best. For filtering lower-frequency noise signals, a larger aluminum electrolytic capacitor of 10 μ F or greater placed near the audio power amplifier is recommended.

● **MIDRAIL BYPASS CAPACITOR, $C_{(BYP)}$**

The midrail bypass capacitor ($C_{(BYP)}$) is the most critical capacitor and serves several important functions. During start-up or recovery from shutdown mode, $C_{(BYP)}$ determines the rate at which the amplifier starts up. The second function is to reduce noise produced by the power supply caused by coupling into the output drive signal. This noise is from the midrail generation circuit internal to the amplifier, which appears as degraded PSRR and THD+N.

Bypass capacitor (C (BYP)) values of 0.47μF to 1μF ceramic or tantalum low-ESR capacitors are recommended for the best THD and noise performance. For the best pop performance, choose a value for C_(BYP) that is equal to or greater than the value chosen for C_i . This ensures that the input capacitors are charged up to the midrail voltage before C_(BYP) is fully charged to the midrail voltage.

● **OUTPUT COUPLING CAPACITOR, C_(C)**

In the typical single-supply SE configuration, an output coupling capacitor (C_(C)) is required to block the dc bias at the output of the amplifier, thus preventing dc currents in the load. As with the input coupling capacitor, the output coupling capacitor and impedance of the load form a high-pass filter governed by Equation 4 .

$$f_{c(\text{high})} = \frac{1}{2\pi R_L C_{(C)}}$$

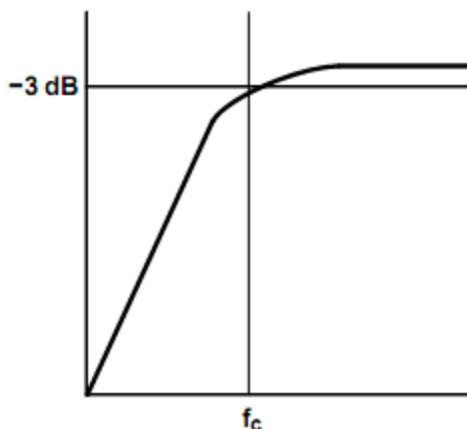

The main disadvantage, from a performance standpoint, is the load impedances are typically small, which drives the low-frequency corner higher, degrading the bass response. Large values of C_(C) are required to pass low frequencies into the load. Consider the example where a C_(C) of 330μ F is chosen and loads vary from 3Ω,4Ω ,8Ω,32Ω ,10kΩ , and 47kΩ . Table 4 summarizes the frequency response characteristics of each configuration.

Table 4. Common Load Impedances vs Low Frequency Output Characteristics in SE Mode

R _L	C _(C)	LOWEST FREQUENCY
3Ω	330μF	161Hz
4Ω	330μF	120Hz
8Ω	330μF	60Hz
32Ω	330μF	15Hz
10,000Ω	330μF	0.05Hz
47,000Ω	330μF	0.01Hz

As Table 4 indicates, most of the bass response is attenuated into a 4Ω load, an 8Ω load is adequate, headphone response is good, and drive into line level inputs (a home stereo for example) is exceptional.

● USING LOW-ESR CAPACITORS

Low-ESR capacitors are recommended throughout this applications section. A real (as opposed to ideal) capacitor can be modeled simply as a resistor in series with an ideal capacitor. The voltage drop across this resistor minimizes the beneficial effects of the capacitor in the circuit. The lower the equivalent value of this resistance, the more the real capacitor behaves like an ideal capacitor.

● BRIDGED-TIED LOAD vs SINGLE-ENDED LOAD

Figure 9 shows a Class-AB audio power amplifier (APA) in a BTL configuration. The LN6011 BTL amplifier consists of two Class-AB amplifiers driving both ends of the load. There are several potential benefits to this differential drive configuration, but, initially consider power to the load. The differential drive to the speaker means that as one side is slewing up, the other side is slewing down, and vice versa. This in effect doubles the voltage swing on the load as compared to a ground referenced load. Plugging $2 \times V_{O(PP)}$ into the power equation, where voltage is squared, yields 4x the output power from the same supply rail and load impedance (see Equation 5).

$$V_{(rms)} = \frac{V_{O(PP)}}{2\sqrt{2}} \quad \text{Power} = \frac{V_{(rms)}^2}{R_L}$$

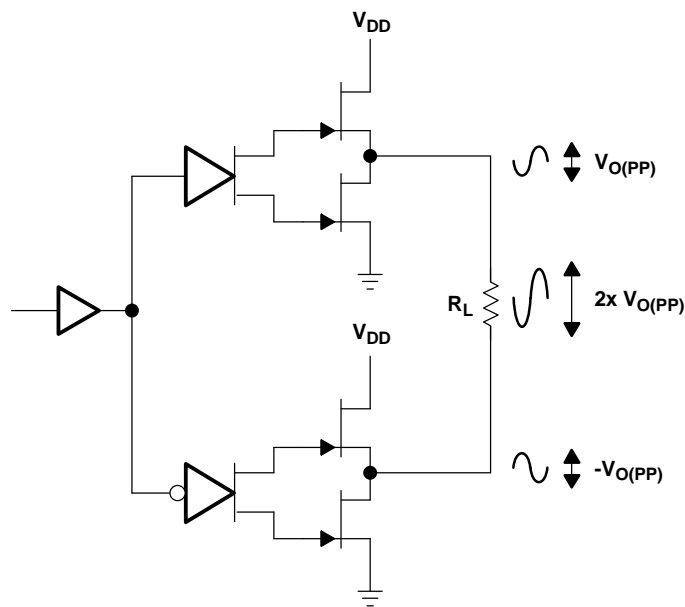

Figure 9. Bridge-Tied Load Configuration

In a typical computer sound channel operating at 5V, bridging raises the power into an 8 Ω speaker from a single-ended (SE, ground reference) limit of 250 mW to 1 W. In sound power that is a 6dB improvement, which is loudness that can be heard. In addition to increased power there are frequency response concerns. Consider the single-supply SE configuration shown in Figure 10. A coupling capacitor is required to block the dc offset voltage from reaching the load. These capacitors can be quite large (approximately 33μ F to 1000μ F), so they tend to be expensive, heavy, occupy valuable PCB area, and have the additional drawback of limiting low-frequency performance of the system. This frequency limiting effect is due to the high-pass filter network created with the speaker impedance and the coupling capacitance and is calculated with Equation 6 .

$$f_{(c)} = \frac{1}{2\pi R_L C_C}$$

For example, a 68μ F capacitor with an 8 Ω speaker would attenuate low frequencies below 293 Hz. The BTL configuration cancels the dc offsets, which eliminates the need for the blocking capacitors. Low-frequency performance is then limited only by the input network and speaker response. Cost and PCB space are also minimized by eliminating the bulky coupling capacitor.

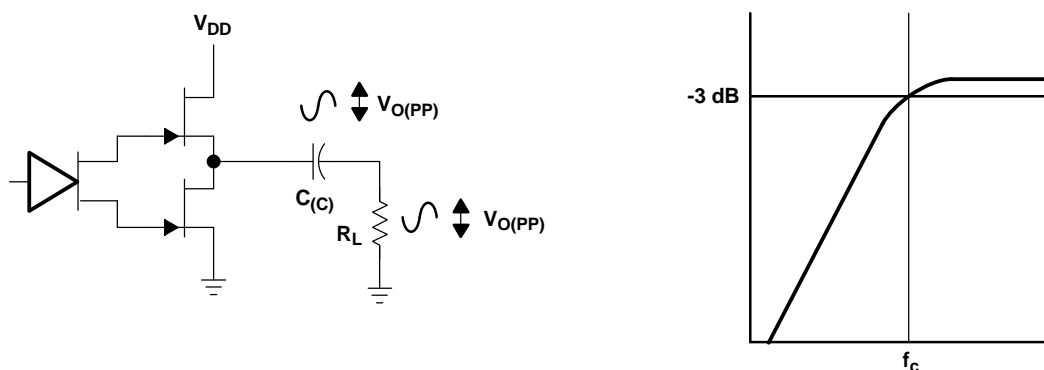

Figure 10. Single-Ended Configuration and Frequency Response

Increasing power to the load does carry a penalty of increased internal power dissipation. The increased dissipation is understandable considering that the BTL configuration produces 4x the output power of the SE configuration. Internal dissipation versus output power is discussed further in the crest factor and thermal considerations section.

● SINGLE-ENDED OPERATION

In SE mode (see Figure 10), the load is driven from the primary amplifier output for each channel (OUT+). The amplifier switches single-ended operation when the SE / BTL terminal is held high. This puts the negative outputs in a high-impedance state, and effectively reduces the amplifier's gain by 6dB.

● BTL AMPLIFIER EFFICIENCY

Class-AB amplifiers are inefficient. The primary cause of these inefficiencies is voltage drop across the output stage transistors. There are two components of the internal voltage drop. One is the headroom or dc voltage drop that varies inversely to output power. The second component is due to the sinewave nature of the output. The total voltage drop can be calculated by subtracting the RMS value of the output voltage from V_{DD} . The internal voltage drop multiplied by the RMS value of the supply current ($I_{DD\ rms}$) determines the internal power dissipation of the amplifier.

An easy-to-use equation to calculate efficiency starts out as being equal to the ratio of power from the power supply to the power delivered to the load. To accurately calculate the RMS and average values of power in the load and in the amplifier, the current and voltage waveform shapes must first be understood (see Figure 11).

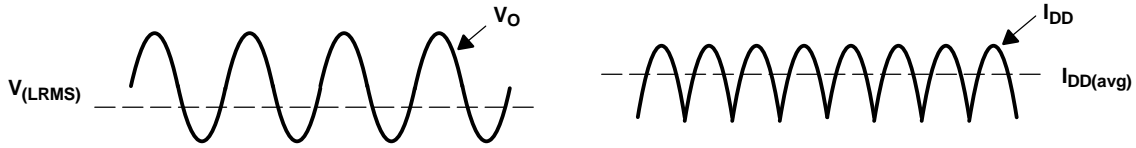

Figure 11. Voltage and Current Waveforms for BTL Amplifiers

Although the voltages and currents for SE and BTL are sinusoidal in the load, currents from the supply are very different between SE and BTL configurations. In an SE application the current waveform is a half-wave rectified shape, whereas in BTL it is a full-wave rectified waveform. This means RMS conversion factors are different. Keep in mind that for most of the waveform both the push and pull transistors are not on at the same time, which supports the fact that each amplifier in the BTL device only draws current from the supply for half the waveform. The following equations are the basis for calculating amplifier efficiency.

$$\text{Efficiency of a BTL amplifier} = \frac{P_L}{P_{SUP}}$$

Where:

$$P_L = \frac{V_{LRMS}^2}{R_L}, \text{ and } V_{LRMS} = \frac{V_P}{\sqrt{2}}, \text{ therefore, } P_L = \frac{V_P^2}{2R_L}$$

$$\text{and } P_{SUP} = V_{DD}I_{DDavg} \text{ and } I_{DDavg} = \frac{1}{\pi} \int_0^{\pi} \frac{V_p}{R_L} \sin(t) dt = \frac{1}{\pi} \times \frac{V_p}{R_L} [\cos(t)]_0^{\pi} = \frac{2V_p}{\pi R_L}$$

$$\text{Therefore, } P_{SUP} = \frac{2V_{DD}V_p}{\pi R_L}$$

Substituting P_L and P_{SUP} into Equation 7

$$\text{Efficiency of a BTL amplifier} = \frac{\frac{V_p^2}{2R_L}}{\frac{2V_{DD}V_p}{\pi R_L}} = \frac{\pi V_p}{4V_{DD}}$$

$$\text{Where: } V_p = \sqrt{2P_L R_L} \text{ Therefore } \eta_{BTL} = \frac{\pi \sqrt{2P_L R_L}}{4V_{DD}}$$

P_L =Power delivered to load

V_P =Peak voltage on BTL load

P_{SUP} =Power drawn from power supply

I_{DDavg} =Average current drawn from the power supply

V_{LRMS} =RMS voltage on BTL load

V_{DD} =Power supply voltage

R_L =Load resistance

η_{BTL} =Efficiency of a BTL amplifier

Table 5 employs Equation 8 to calculate efficiencies for four different output power levels. Note that the efficiency of the amplifier is quite low for lower power levels and rises sharply as power to the load is increased resulting in a nearly flat internal power dissipation over the normal operating range. Note that the internal dissipation at full output power is less than in the half power range. Calculating the efficiency for a specific system is the key to proper power supply design. For a stereo 1W audio system with 8Ω loads and a 5V supply, the maximum draw on the power supply is almost 3.25 W.

Table 5. Efficiency vs Output Power in 5V, 8

OUTPUT POWER(W)	EFFICIENCY(%)	PEAK VOLTAGE(V)	INTERNAL DISSIPATION(W)
0.25	31.4	2.00	0.55
0.50	44.4	2.83	0.62
1.00	62.8	4.00	0.59
1.25	70.2	4.47 ⁽¹⁾	0.53

(1) High peak voltage cause the THD to increase.

A final point to remember about Class-AB amplifiers (either SE or BTL) is how to manipulate the terms in the efficiency equation to utmost advantage when possible. Note that in equation 8, V_{DD} is in the denominator. This indicates that as V_{DD} goes down, efficiency goes up.

● CREST FACTOR AND THERMAL CONSIDERATIONS

Class-AB power amplifiers dissipate a significant amount of heat in the package under normal operating conditions. A typical music CD requires 12dB to 15dB of dynamic range, or headroom above the average power output, to pass the loudest portions of the signal without distortion. In other words, music typically has a crest factor between 12dB and 15dB. When determining the optimal ambient operating temperature, the internal dissipated power at the average output power level must be used. From the LN6011 data sheet, one can see that when the LN6011 is operating from a 5V supply into a 3Ω speaker, that 4W peaks are available. Use equation 9 to convert watts to dB.

$$P_{dB} = 10 \log \frac{P_w}{P_{ref}} = 10 \log \frac{4W}{1W} = 6dB$$

Subtracting the headroom restriction to obtain the average listening level without distortion yields:

- 6 dB - 15 dB = -9 dB (15dB crest factor)
- 6 dB - 12 dB = -6 dB (12dB crest factor)
- 6 dB - 9 dB = -3 dB (9dB crest factor)
- 6 dB - 6 dB = 0 dB (6dB crest factor)
- 6 dB - 3 dB = 3 dB (3dB crest factor)

To convert dB back into watts use equation 10.

$$P_w = 10^{\frac{P_{dB}}{10}} \times P_{ref}$$

=63 mW (18dB crest factor)
 =125 mW (15dB crest factor)
 =250 mW (12dB crest factor)
 =500 mW (9dB crest factor)
 =1000 mW (6dB crest factor)
 =2000 mW (3dB crest factor)

This is valuable information to consider when attempting to estimate the heat dissipation requirements for the amplifier system. Comparing the worst case, which is 2W of continuous power output with a 3dB crest factor, against 12dB and 15dB applications significantly affects maximum ambient temperature ratings for the system. Using the power dissipation curves for a 5VΩ3 system, the internal dissipation in the LN6011 and maximum ambient temperatures is shown in Table 6 .

Table 6. LN6011 Power Rating, 5V, 3 Ω Stereo

PEAK OUTPUT POWER (W)	AVERAGE OUTPUT POWER	POWER DISSIPATION (W/Channel)	MAXIMUM AMBIENT TEMPERATURE
4	2 W (3dB)	1.7	-3°C
4	1 W (6dB)	1.6	6°C
4	500 mW (9dB)	1.4	24°C
4	250 mW (12dB)	1.1	51°C
4	125 mW (15dB)	0.8	78°C
4	63 mW (18dB)	0.6	96°C

Table 7. LN6011 Power Rating, 5V, 8 Ω Stereo

PEAK OUTPUT POWER (W)	AVERAGE OUTPUT POWER	POWER DISSIPATION (W/Channel)	MAXIMUM AMBIENT TEMPERATURE
2.5	1250 mW (3dB crest factor)	0.55	100°C
2.5	1000 mW (4dB crest factor)	0.62	94°C
2.5	500 mW (7dB crest factor)	0.59	97°C
2.5	250 mW (10dB crest factor)	0.53	102°C

The maximum dissipated power ($P_{D(max)}$) is reached at a much lower output power level for an 8 Ω load than for a 3 Ω load. As a result, this simple formula for calculating $P_{D(max)}$ may be used for an 8 Ω application.

$$P_{D(max)} = \frac{2V_{DD}^2}{\pi^2 R_L}$$

However, in the case of a 3 Ω load, the $P_{D(max)}$ occurs at a point well above the normal operating power level. The amplifier may therefore be operated at a higher ambient temperature than required by the $P_{D(max)}$ formula for a 3 Ω load.

The maximum ambient temperature depends on the heat-sinking ability of the PCB system. The derating factor for the PWP package is shown in the dissipation rating table. Use equation 12 to convert this to θ_{JA} .

$$\theta_{JA} = \frac{1}{\text{DeratingFactor}} = \frac{1}{0.022} = 45 \text{ } ^\circ\text{C/W}$$

To calculate maximum ambient temperatures, first consider that the numbers from the dissipation graphs are per channel, so the dissipated power needs to be doubled for two channel operation. Given θ_{JA} , the maximum allowable junction temperature, and the total internal dissipation, the maximum ambient temperature can be calculated using Equation 13. The maximum recommended junction temperature for the LN6011 is 150°C. The internal dissipation figures are taken from the Power Dissipation vs Output Power graphs.

$$\begin{aligned} T_{A\text{Max}} &= T_{J\text{Max}} - \theta_{JA} P_D \\ &= 150 - 45(0.6 \times 2) = 96^\circ\text{C} \text{ (15 dB crest factor)} \end{aligned}$$

NOTE: Internal dissipation of 0.6 W is estimated for a 2W system with 15dB crest factor per channel.

Table 6 and Table 7 show that some applications require no airflow to keep junction temperatures in the specified range. The LN6011 is designed with thermal protection that turns the device off when the junction temperature surpasses 150°C to prevent damage to the IC. Table 6 and Table 7 were calculated for maximum listening volume without distortion. When the output level is reduced the numbers in the table change significantly. Also, using 8 Ω speakers increases the thermal performance by increasing amplifier efficiency.

Typical Performance Characteristics

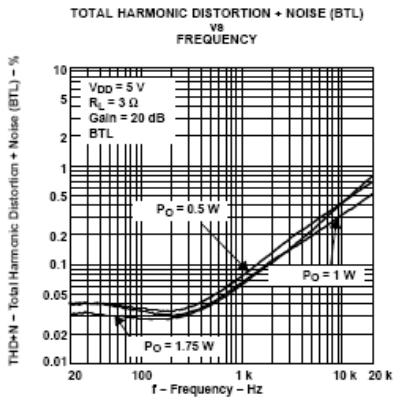

Figure 1.

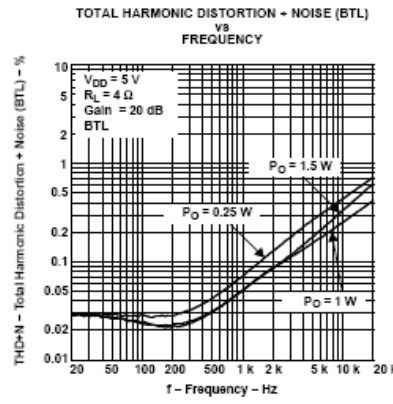

Figure 2.

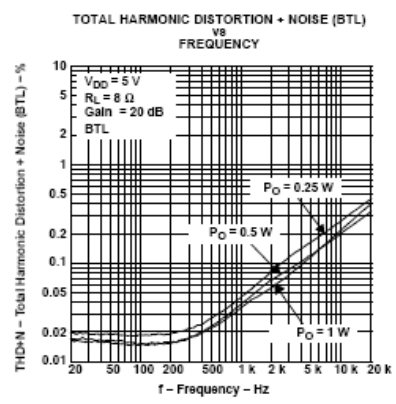

Figure 3.

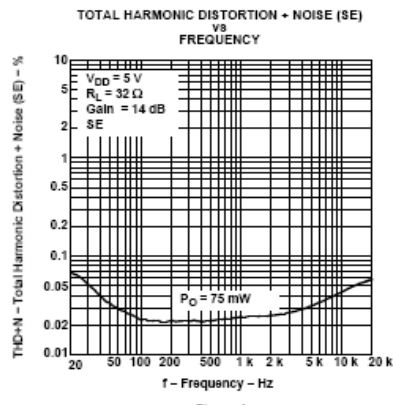

Figure 4.

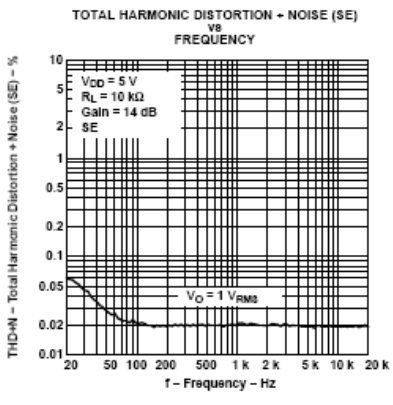

Figure 5.

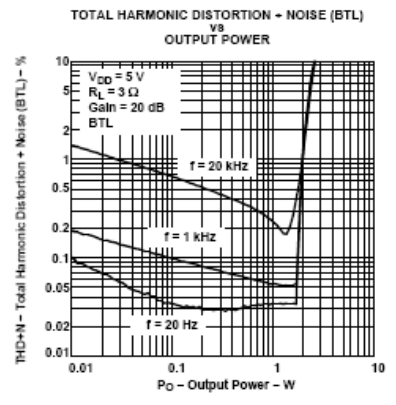

Figure 6.

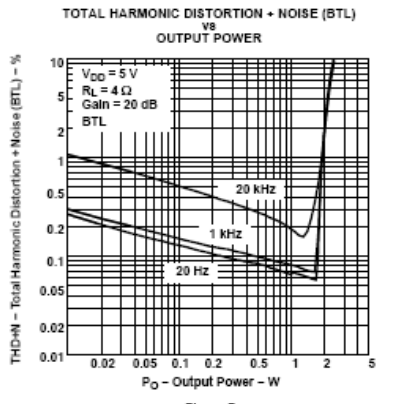

Figure 7.

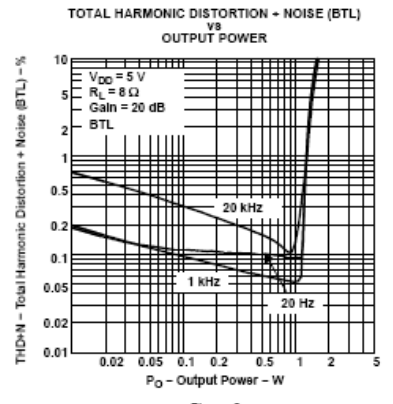

Figure 8.

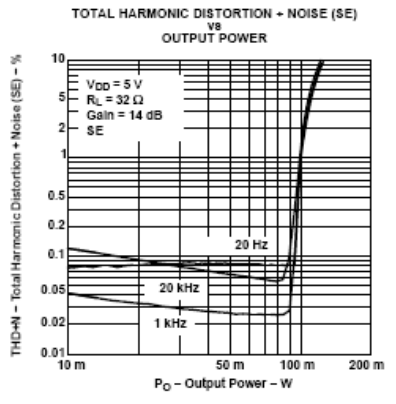

Figure 9.

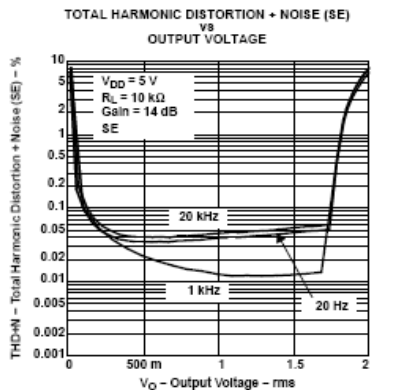

Figure 10.

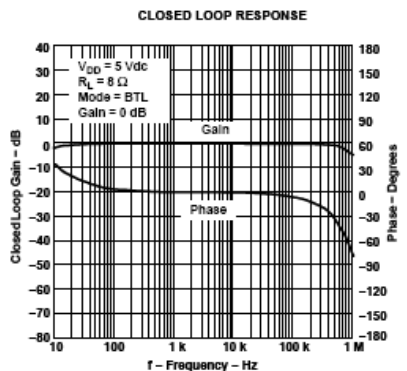

Figure 11.

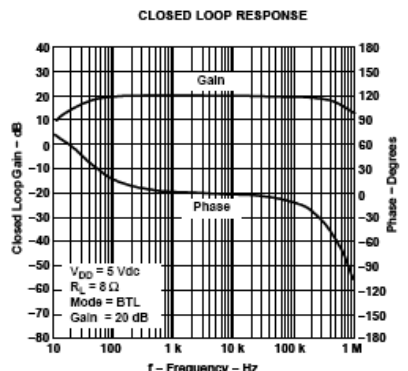

Figure 12.

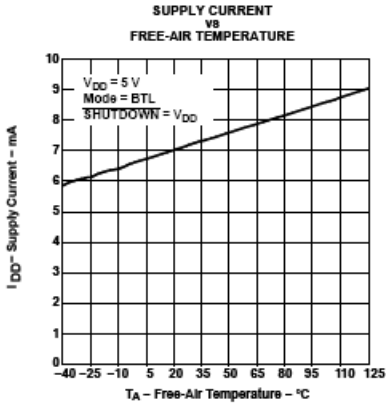

Figure 13.

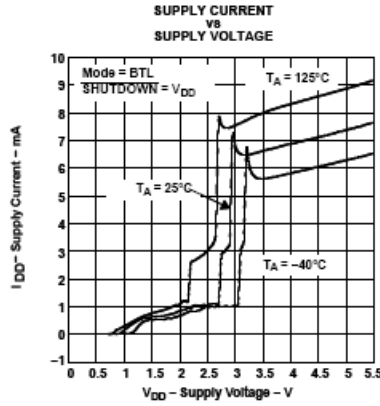

Figure 14.

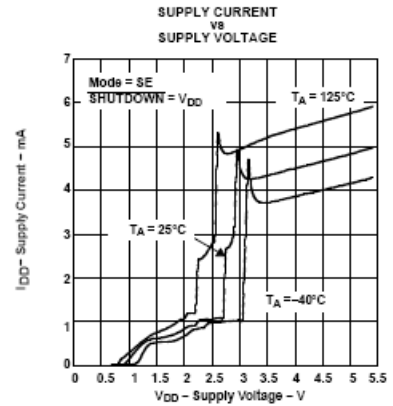

Figure 15.

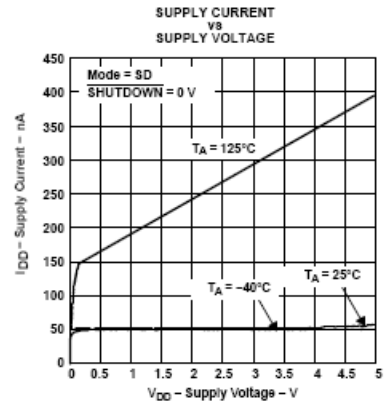

Figure 16.

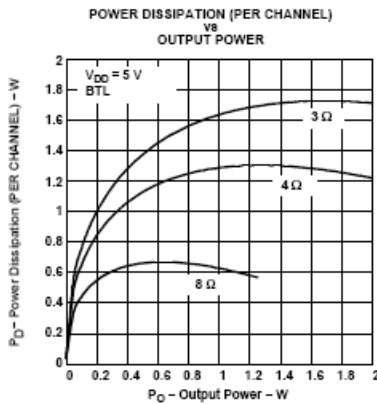

Figure 17.

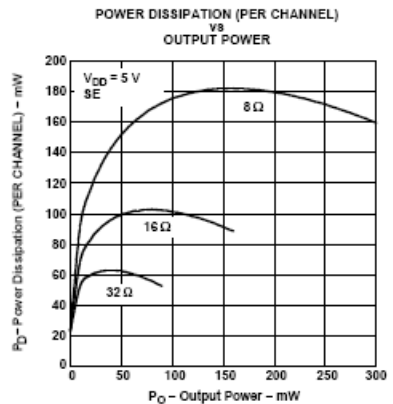

Figure 18.

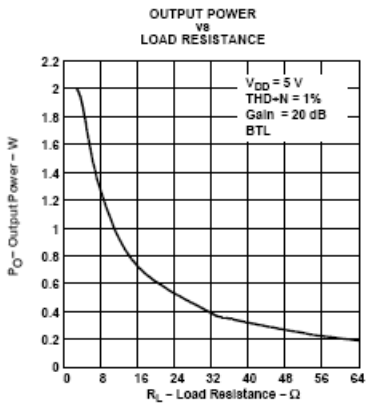

Figure 19.

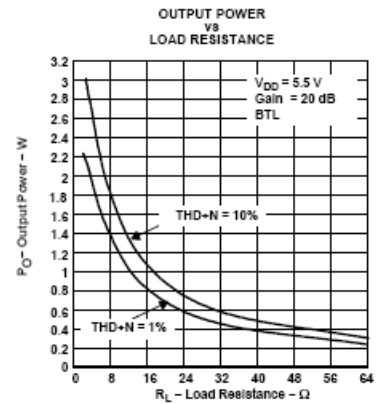

Figure 20.

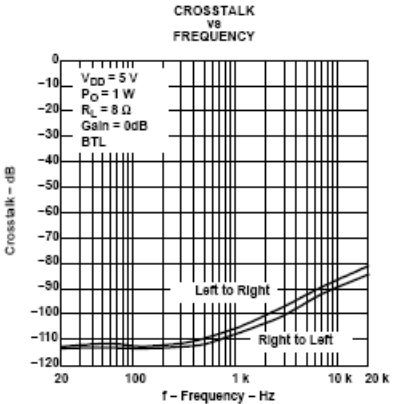

Figure 21.

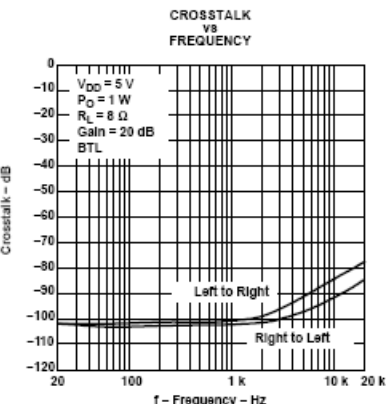

Figure 22.

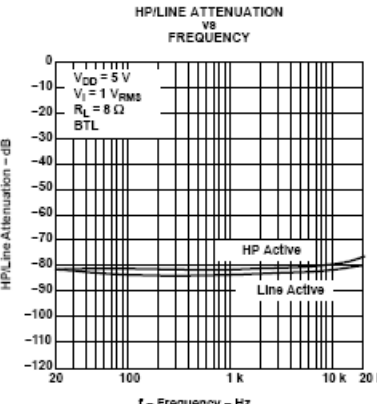

Figure 23.

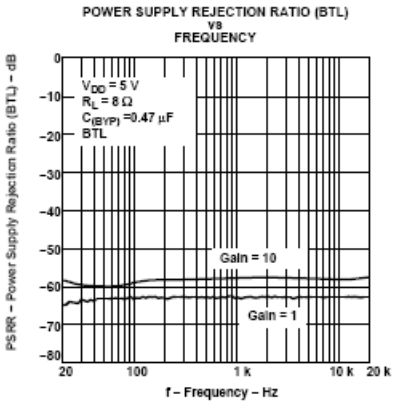

Figure 24.

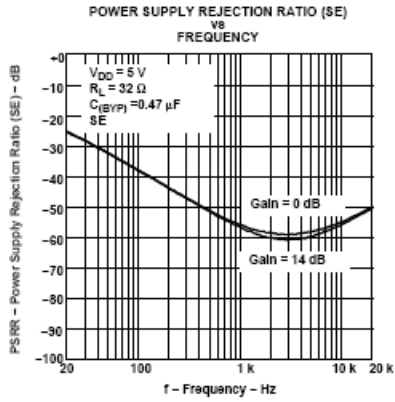

Figure 25.

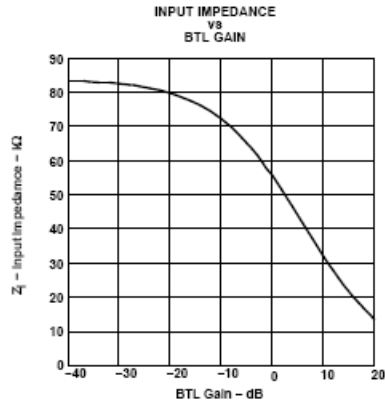

Figure 26.

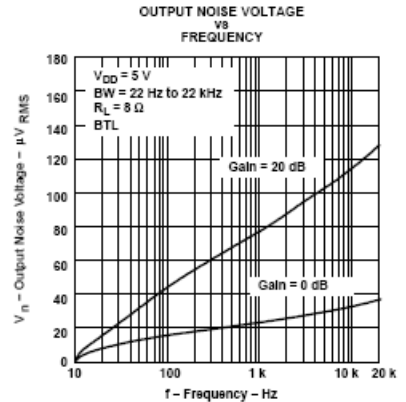
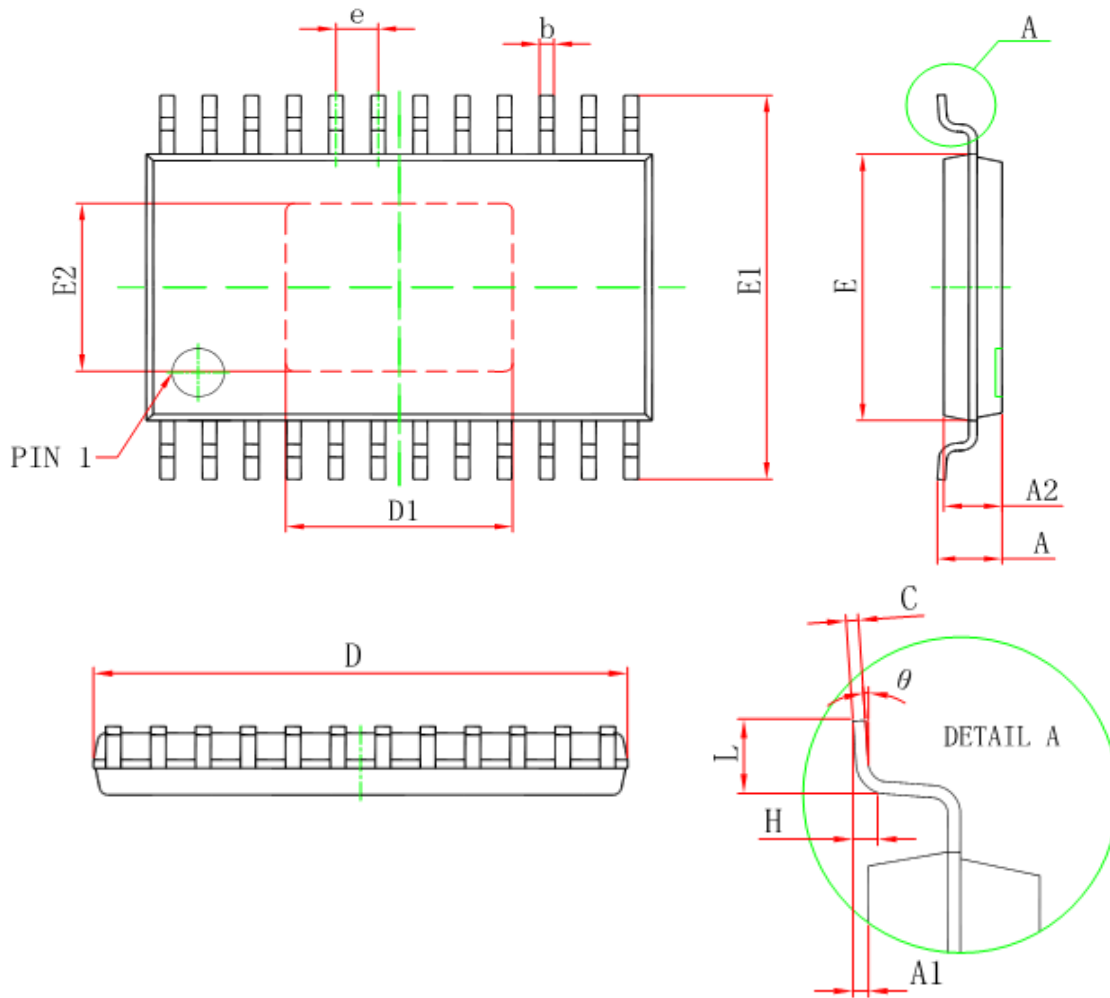

Figure 27.

■ Package Information

- TSSOP-24/PP



Symbol	Dimensions In Millimeters		Dimensions In Inches	
	Min	Max	Min	Max
D	7.700	7.900	0.303	0.311
D1	3.400	3.600	0.134	0.138
E	4.300	4.500	0.169	0.177
b	0.190	0.300	0.007	0.012
e	0.090	0.200	0.004	0.008
E1	6.250	6.550	0.246	0.258
E2	2.700	2.900	0.106	0.122
A		1.100		0.043
A2	0.800	1.000	0.031	0.039
A1	0.020	0.150	0.001	0.006
e	0.65 (BSC)		0.026 (BSC)	
L	0.500	0.700	0.02	0.028
H	0.25(TYP)		0.01(TYP)	
θ	1°	7°	1°	7°