

LN61C

GaAs 赤外発光ダイオード / GaAs Infrared Light Emitting Diode

各種光制御機器用 / For Optical Control Systems

■ 特徴 / Features

- 高出力, 高効率: $P_o=6\text{ mW (typ.)}$ / High power output: $P_o=6\text{ mW (typ.)}$
- 単色光に近い赤外光を放射: $\lambda_p=950\text{ nm (typ.)}$ / Infrared radiation: $\lambda_p=950\text{ nm (typ.)}$

■ 絶対最大定格 / Absolute Maximum Ratings ($T_a=25\text{ }^\circ\text{C}$)

Item	Symbol	Value	Unit
許容損失	P_D	160	mW
順電流(直流値)	I_F	100	mA
パルス順電流	I_{FP}^*	1.5	mA
逆電圧(直流値)	V_R	3	V
動作周囲温度	T_{opr}	-25 ~ +100	$^\circ\text{C}$
保存温度	T_{stg}	-40 ~ +100	$^\circ\text{C}$

* $f=100\text{ Hz}$, Duty Cycle=0.1%

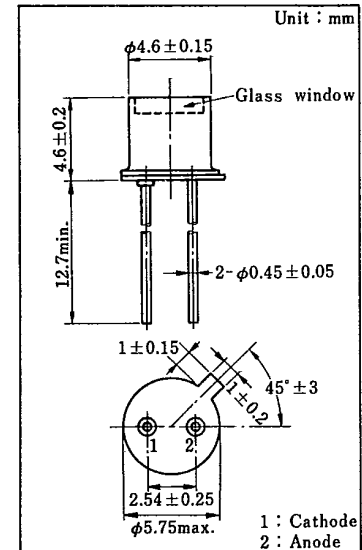

■ 電氣的・光学的特性 / Electro-Optical Characteristics ($T_a=25\text{ }^\circ\text{C}$)

Item	Symbol	Condition	min.	typ.	max.	Unit
光出力	P_o	$I_F=100\text{ mA}$	3	6		mW
ピーク発光波長	λ_p	$I_F=100\text{ mA}$		950		nm
スペクトル半値幅	$\Delta\lambda$	$I_F=100\text{ mA}$		50		nm
順電圧(直流値)	V_F	$I_F=100\text{ mA}$		1.3	1.6	V
逆電流(直流値)	I_R	$V_R=3\text{ V}$			10	μA
端子間全容量	C_t	$V_R=0, f=1\text{ MHz}$		60		pF
半値角	θ	光強度 50% の角度		35		deg

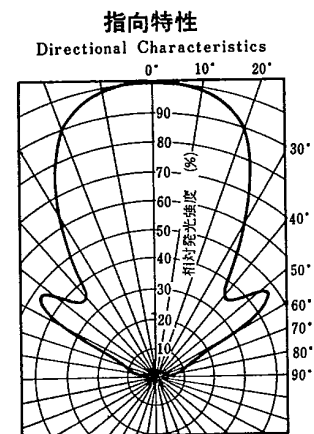
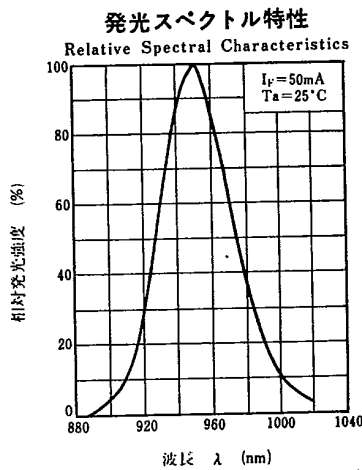
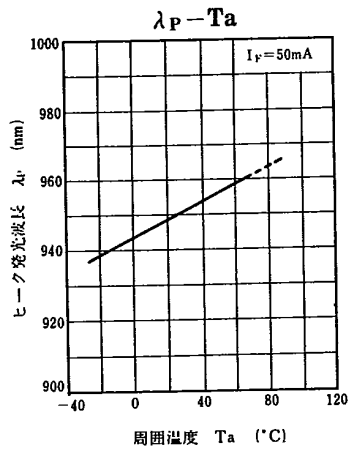
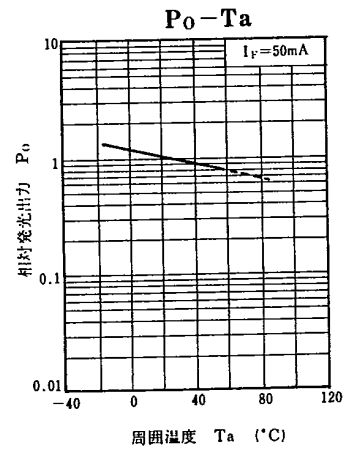
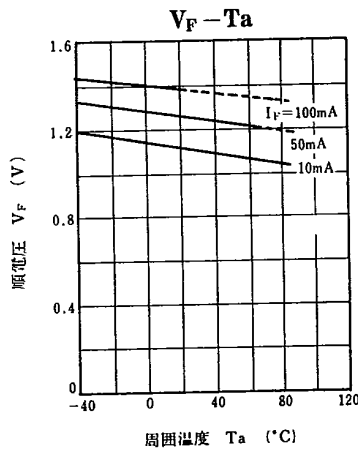
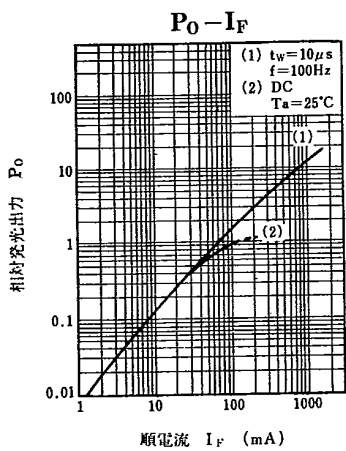
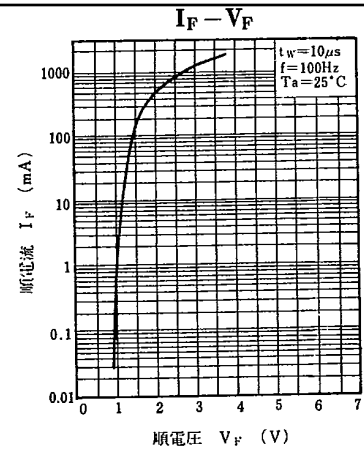
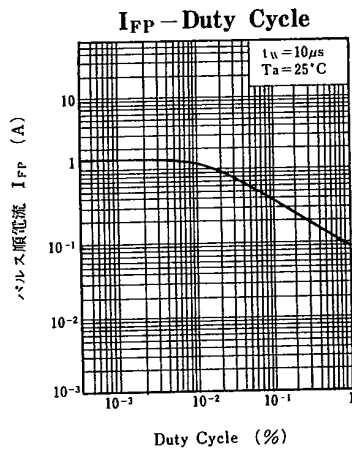
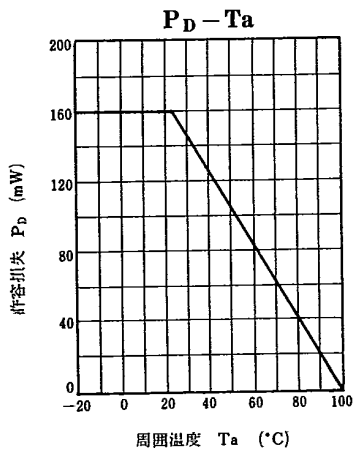

LN62S

GaAs 赤外発光ダイオード / GaAs Infrared Light Emitting Diode

各種光制御機器用 / For Optical Control Systems
 PN120S など各種シリコン受光素子との組み合わせでホトインタ
 ラプタを構成。 / Matched arrangement with PN120S

■ 特徴 / Features

- 高出力, 高効率: $P_o=3.5$ mW (typ.) / High power output: $P_o=3.5$ mW (typ.)
- 応答速度が速い: $t_r, t_f=1.5$ μ s (typ.) / Fast response: $t_r, t_f=1.5$ μ s (typ.)
- 単色光に近い赤外光を放射: $\lambda_p=950$ nm (typ.) / Infrared radiation: $\lambda_p=950$ nm (typ.)
- 小形セラミックパッケージ。 / Small size ceramic package

■ 絶対最大定格 / Absolute Maximum Ratings (Ta=25 °C)

Item	Symbol	Value	Unit
許容損失	P_D	75	mW
順電流(直流値)	I_F	50	mA
パルス順電流	I_{FP}^*	1	A
逆電圧(直流値)	V_R	3	V
動作周囲温度	T_{opr}	-25 ~ +85	°C
保存温度	T_{stg}	-30 ~ +100	°C

* $f=100$ Hz, Duty Cycle=0.1%

■ 電氣的・光学的特性 / Electro-Optical Characteristics (Ta=25 °C)

Item	Symbol	Condition	min.	typ.	max.	Unit
光出力	P_o	$I_F=50$ mA	1.5	3.5		mW
ピーク発光波長	λ_p	$I_F=50$ mA		950		nm
スペクトル半値幅	$\Delta\lambda$	$I_F=50$ mA		50		nm
順電圧(直流値)	V_F	$I_F=50$ mA		1.2	1.5	V
逆電流(直流値)	I_R	$V_R=3$ V			10	μ A
端子間全容量	C_t	$V_R=0$ V, $f=1$ MHz		50		pF
上昇時間	t_r	$I_{FP}=50$ mA		1.5		μ s
下降時間	t_f			1.5		μ s
半値角	θ	光強度 50% の角度		80		deg

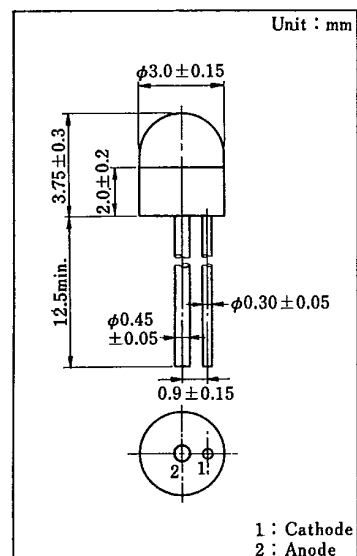

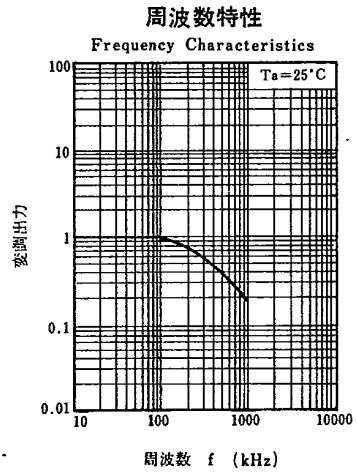
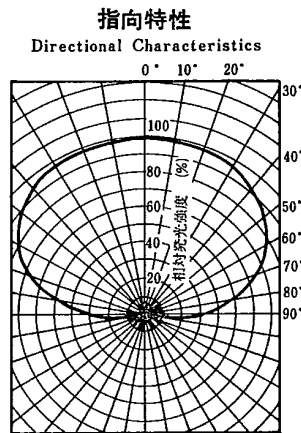
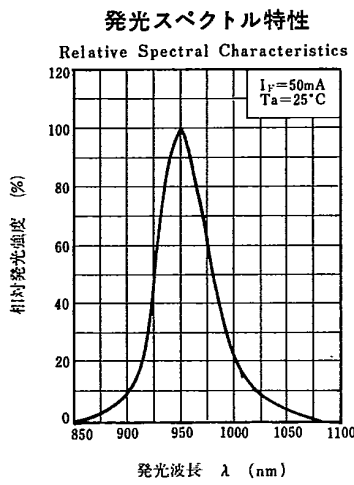
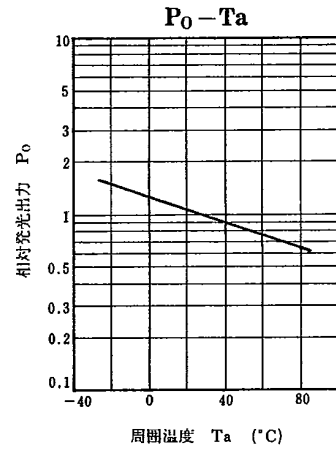
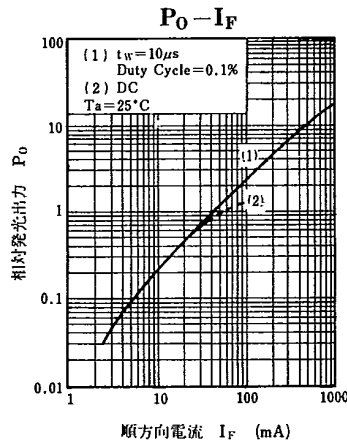
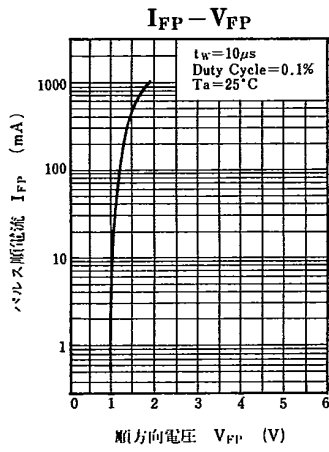
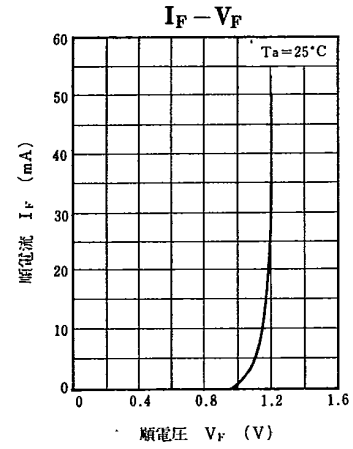
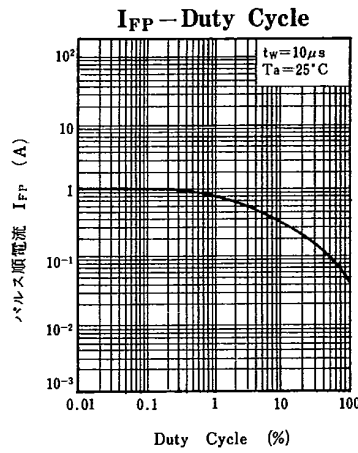
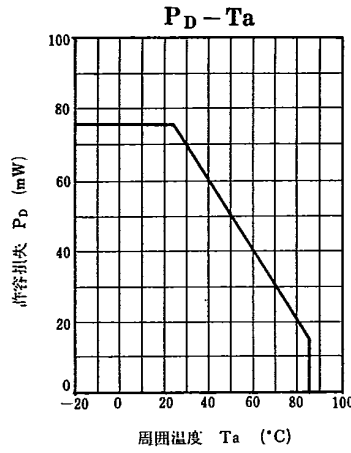

LN65

GaAs 赤外発光ダイオード / GaAs Infrared Light Emitting Diode

各種光制御機器用 / For Optical Control Systems

■ 特徴 / Features

- 高出力, 高効率: $P_o=5.5$ mW (typ.)。 / High power output: $P_o=5.5$ mW (typ.)
- 光出力対電流の直線性がよい。 / Good linearity of P_o vs I_F
- 高速変調での応用に適している。 / High frequency response
- 単色光に近い赤外光を放射: $\lambda_P=950$ nm (typ.)。 / Infrared radiation: $\lambda_P=950$ nm (typ.)

■ 絶対最大定格 / Absolute Maximum Ratings ($T_a=25^\circ\text{C}$)

Item	Symbol	Value	Unit
許容損失	P_D	160	mW
順電流(直流値)	I_F	100	mA
パルス順方向電流	I_{FP}^*	1.5	A
逆電圧(直流値)	V_R	3	V
動作周囲温度	T_{opr}	-25 ~ +85	$^\circ\text{C}$
保存温度	T_{stg}	-40 ~ +100	$^\circ\text{C}$

* $f=100$ Hz, Duty Cycle=0.1%

■ 電氣的・光学的特性 / Electro-Optical Characteristics ($T_a=25^\circ\text{C}$)

Item	Symbol	Condition	min.	typ.	max.	Unit
光出力	P_o	$I_F=100$ mA	4.3	5.5		mW
ピーク発光波長	λ_P	$I_F=100$ mA		950		nm
スペクトル半値幅	$\Delta\lambda$	$I_F=100$ mA		50		nm
順電圧(直流値)	V_F	$I_F=100$ mA		1.3	1.6	V
逆電流(直流値)	I_R	$V_R=3$ V			10	μA
端子間全容量	C_t	$V_R=0$, $f=1$ MHz		50		pF
半値角	θ	光強度 50% の角度		35		deg

