

## 700 mA Low Dropout CMOS Voltage Regulators

### ■ General Description

The LN6210 series are highly precise, low noise, positive voltage LDO regulators manufactured using CMOS processes. The series achieves high ripple rejection and low dropout and consists of a standard voltage source, an error correction, current limiter and a phase compensation circuit plus a driver transistor. Output voltage is selectable in 100mV increments within a range of 1.0V ~ 5.0V. The series is also compatible with low ESR ceramic capacitors which give added output stability. This stability can be maintained even during load fluctuations due to the excellent transient response of the series.

The CE function enables the output to be turned off, resulting in greatly reduced power consumption.

### ■ Features

- Output voltage range : 1.0V to 5.0V (selectable in 100mV steps)
- Highly accurate :  $\pm 2\%$
- Dropout voltage : 50mV @ 100mA (3.0V type)

### ■ Ordering Information

#### LN6210 ①②③④⑤⑥

Designator	Symbol	Description
①		CE Pin Logic :
	A	Active 'High' (pull-down resistor built in)
	B	Active 'High' (no pull-down resistor built in)
	C	Active 'Low' (pull-up resistor built in)
②③	D	Active 'Low' (no pull-up resistor built in)
	18-60	Output Voltage:e.g. ②=3, ③=0 $\Rightarrow$ 3.0V
④	2	Output Voltage : 100mV increments e.g. ②=3, ③=8, ④=2 $\Rightarrow$ 3.8V
	A	Output Voltage : 50mV increments e.g. ②=3, ③=8, ④=A $\Rightarrow$ 3.85V
⑤		Package Type :
	M	SOT-23-5L
	P	SOT-89-5L
⑥	D	DFNWB1.8 $\times$ 2-6L
		Device Orientation :
	R	Embossed Tape : Standard Feed
	L	Embossed Tape : Reverse Feed

- High ripple rejection : 60dB (1 kHz)
- Low power consumption : 30 $\mu$ A (TYP.)
- Maximum output current : 700mA ( $V_{IN} \geq V_{OUT} + 1V$ )
- Standby current : less than 0.1 $\mu$ A
- Internal protector : current limiter

### ■ Applications

- CD-ROMs, CD-R/RW drive
- DVD drive
- HDD drive
- Cameras, Video cameras
- Portable AV equipment
- Battery powered equipment

### ■ Package

- SOT-23-5L
- DFNWB1.8 $\times$ 2-6L
- SOT-89-5L

## Pin Configuration

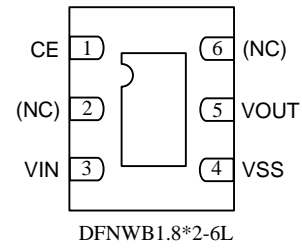
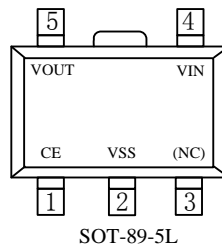
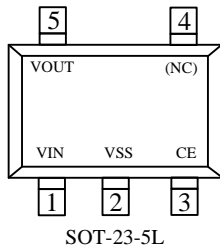

## Pin Assignment

Pin Number			Pin Name	Function
SOT-23-5L	SOT-89-5L	DFNWB1.8×2-6L		
1	4	3	VIN	Supply Power
2	2	4	VSS	Ground
3	1	1	CE	Enable Pin
4	3	2, 6	NC	Nc
5	5	5	VOUT	Voltage Output

## Marking Rule

- SOT-23-5L / SOT-89-5L

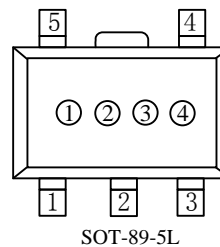
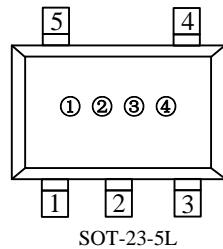

- ① Represents the product name

Symbol	Product Name
0	LN6210◆◆◆◆◆◆

- ② Represents the type of regulator

Voltage(V)	1.0~3.0	3.1~6.0	1.05~3.05	3.15~6.05		
Symbol	V	A	E	L	Product Name	LN6210A◆◆◆◆◆◆
	X	B	F	M		LN6210B◆◆◆◆◆◆
	Y	C	H	N		LN6210C◆◆◆◆◆◆
	Z	D	K	P		LN6210D◆◆◆◆◆◆

③ Represents the Output Voltage

Symbol	Output Voltage (V)			
0		3.1		3.15
1		3.2		3.25
2		3.3		3.35
3		3.4		3.45
4		3.5		3.55
5		3.6		3.65
6		3.7		3.75
7		3.8		3.85
8		3.9		3.95
9	1.0	4.0	1.05	4.05
A	1.1	4.1	1.15	4.15
B	1.2	4.2	1.25	4.25
C	1.3	4.3	1.35	4.35
D	1.4	4.4	1.45	4.45
E	1.5	4.5	1.55	4.55

Symbol	Output Voltage (V)			
F	1.6	4.6	1.65	4.65
H	1.7	4.7	1.75	4.75
K	1.8	4.8	1.85	4.85
L	1.9	4.9	1.95	4.95
M	2.0	5.0	2.05	5.05
N	2.1		2.15	
P	2.2		2.25	
R	2.3		2.35	
S	2.4		2.45	
T	2.5		2.55	
U	2.6		2.65	
V	2.7		2.75	
X	2.8		2.85	
Y	2.9		2.95	
Z	3.0		3.05	

④ Represents the assembly lot no.

0~9, A~Z repeated (G, I, J, O, Q, W excepted)

- DFNWB1.8×2-6L

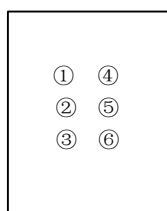

DFNWB1.8\*2-6L

① ② Represents the product name

Symbol		Product Name
①	②	
1	0	LN6210XXXXDX

③ Represents the type of regulator

Symbol	Type	Product Name
A	Active 'High' (pull-down resistor built in)	LN6210AXXXDX
B	Active 'High' (no pull-down resistor built in)	LN6210BXXDX
C	Active 'Low' (pull-up resistor built in)	LN6210CXXDX
D	Active 'Low' (no pull-up resistor built in)	LN6210DXXDX

④ Represents the integers of Output Voltage

Example: 3 represents 3.x,5 represents 5.x;

⑤ Represents the decimals of Output Voltage

Symbol	Voltage(V)	Product Name
0	X.0	LN6210XX0XDX
1	X.1	LN6210XX1XDX
2	X.2	LN6210XX2XDX
3	X.3	LN6210XX3XDX
4	X.4	LN6210XX4XDX
5	X.5	LN6210XX5XDX
6	X.6	LN6210XX6XDX
7	X.7	LN6210XX7XDX
8	X.8	LN6210XX8XDX
9	X.9	LN6210XX9XDX

Symbol	Voltage(V)	Product Name
A	X.05	LN6210XXAXDX
B	X.15	LN6210XXBXDX
C	X.25	LN6210XXCXDX
D	X.35	LN6210XXDXDX
E	X.45	LN6210XXEXDX
F	X.55	LN6210XXFXDX
H	X.65	LN6210XXHXDX
K	X.75	LN6210XXKXDX
L	X.85	LN6210XXLXDX
M	X.95	LN6210XXMXDX

⑥ Represents the assembly lot No.

0~9, A~Z repeated (G, I, J, O, Q, W excepted)

■ Function Block Diagram

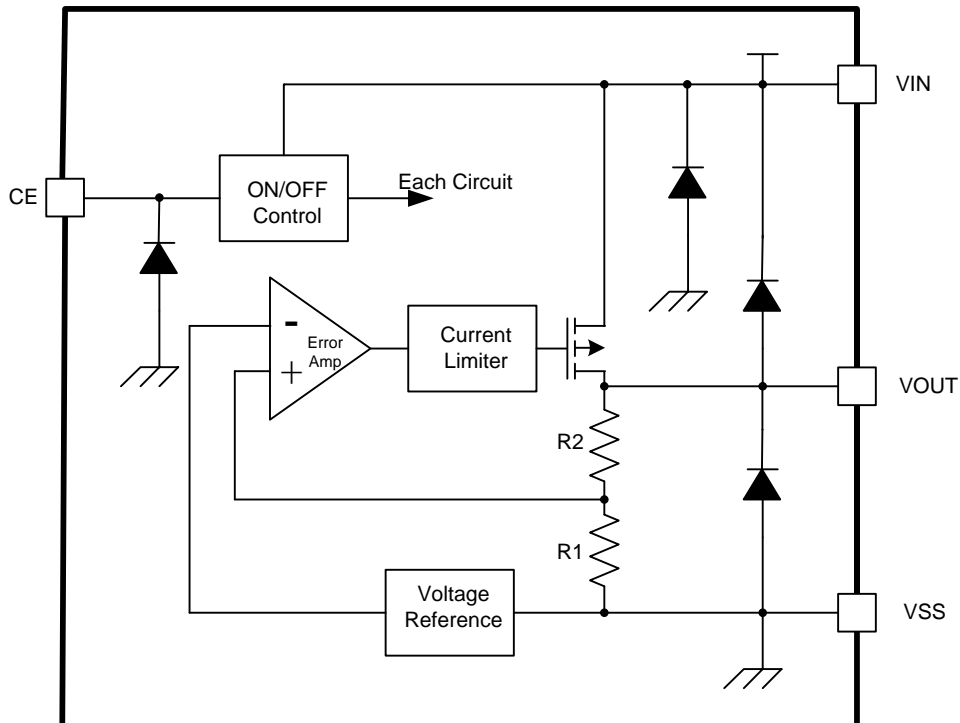

## Absolute Maximum Ratings

Parameter	Symbol	Maximum Rating	Unit
Input Voltage	$V_{IN}$	$V_{SS}-0.3 \sim V_{SS}+8$	V
	$V_{ON/OFF}$	$V_{SS}-0.3 \sim V_{IN}+0.3$	
Output Current	$V_{OUT}$	$V_{SS}-0.3 \sim V_{IN}+0.3$	
Power Dissipation	$P_D$	SOT-23-5L	400
		SOT-89-5L	500
		DFNWB1.8×2-6L	100
Operating Ambient Temperature	$T_{opr}$	$-40 \sim +85$	°C
Storage Temperature	$T_{stg}$	$-40 \sim +125$	

**Caution:** The absolute maximum ratings are rated values exceeding which the product could suffer physical damage. These values must therefore not be exceeded under any conditions.

## Typical Application Circuit

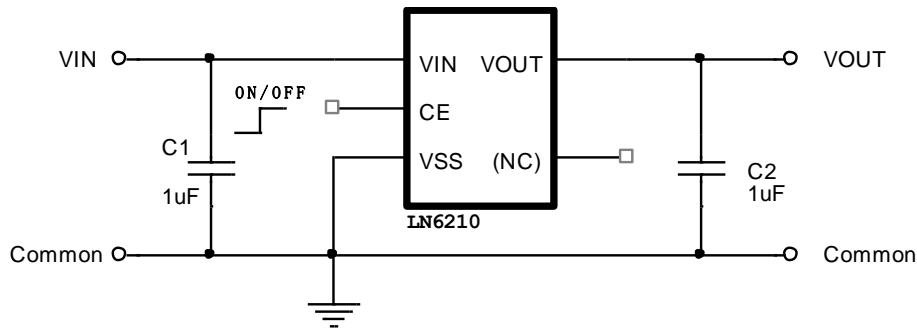

**Caution:** The above connection diagram and constant will not guarantee successful operation. Perform thorough evaluation using the actual application to set the constant.

## Application Conditions

Input capacitor (CIN): 1.0µF or more

Output capacitor (CL): 1.0µF or more (tantalum capacitor)

**Caution** A general series regulator may oscillate, depending on the external components selected. Check that no oscillation occurs with the application using the above capacitor.

## Test Circuits

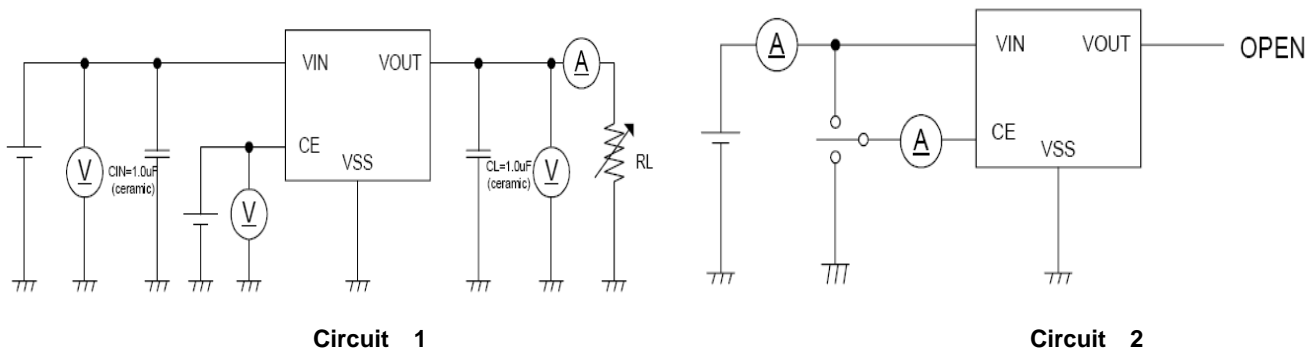

**Electrical Characteristics**

Parameter	Symbol	Condition	Min	Typ	Max	Unit	Circuit	
Output Voltage	$V_{OUT(E)}$	$V_{IN} = V_{OUT(S)} + 1.0 \text{ V}$ , $I_{OUT} = 30 \text{ mA}$	$V_{OUT(S)} \times 0.98$	$V_{OUT(S)}$	$V_{OUT(S)} \times 1.02$	V	1	
Output Current	$I_{OUT}$	$V_{IN} \geq V_{OUT(S)} + 1.0 \text{ V}$	700	—	—	mA	1	
Dropout Voltage	$V_{drop}$	$I_{OUT} = 30 \text{ mA}$	—	0.015	0.023	V	1	
		$I_{OUT} = 100 \text{ mA}$	—	0.050	0.075			
Line Regulations	$\frac{\Delta V_{OUT1}}{\Delta V_{IN} \cdot V_{OUT}}$	$V_{OUT(S)} + 0.5 \text{ V} \leq V_{IN} \leq 7 \text{ V}$ $I_{OUT} = 30 \text{ mA}$	—	0.010	0.2	%/V		
Load Regulation	$\Delta V_{OUT2}$	$V_{IN} = V_{OUT(S)} + 1.0 \text{ V}$ $1.0 \text{ mA} \leq I_{OUT} \leq 100 \text{ mA}$	—	15	60	mV		
Output Voltage Temperature Characteristics	$\frac{\Delta V_{OUT}}{\Delta T_a \cdot V_{OUT}}$	$V_{IN} = V_{OUT(S)} + 1.0 \text{ V}$ , $I_{OUT} = 10 \text{ mA}$ $-40^\circ\text{C} \leq T_a \leq 85^\circ\text{C}$	—	$\pm 100$	—	ppm/ $^\circ\text{C}$		
Supply Current	$I_{SS1}$	$V_{IN} = V_{OUT(S)} + 1.0 \text{ V}$	—	30	—	$\mu\text{A}$		2
Input Voltage	$V_{IN}$	—	2.0	—	7.0	V		—
Ripple-Rejection	PSRR	$V_{IN} = V_{OUT(S)} + 1.0 \text{ V}$ , $f = 1 \text{ kHz}$ $V_{rip} = 0.5 \text{ V}_{rms}$ , $I_{OUT} = 50 \text{ mA}$	—	60	—	dB	1	
Short-circuit Current	$I_{short}$	$V_{IN} = V_{OUT(S)} + 1.0 \text{ V}$ , $V_{CE}$ on $V_{OUT} = \text{gnd}$	—	60	—	mA	1	
Current limiter	$I_{lim}$	$V_{OUT} = 3.3 \text{ V}$ $V_{IN} = V_{OUT(S)} + 1.0 \text{ V}$ , $V_{ce} = \text{ON}$	—	1100	—	mA	1	
CE "High" Voltage	$V_{CEH}$		1.3		$V_{IN}$	V	1	
CE "Low" Voltage	$V_{CEL}$				0.25	V	1	
CE "High" Current	$I_{CEH}$	$V_{IN} = V_{CE} = V_{OUT(T)} + 1.0 \text{ V}$	-0.1		0.1	$\mu\text{A}$	2	
CE "Low" Current	$I_{CEL}$	$V_{IN} = V_{OUT(T)} + 1.0 \text{ V}$ , $V_{CE} = V_{SS}$	-0.1		0.1	$\mu\text{A}$	2	

## Typical Performance Characteristics (3.0V output)

### 1. Output Voltage vs. Output Current

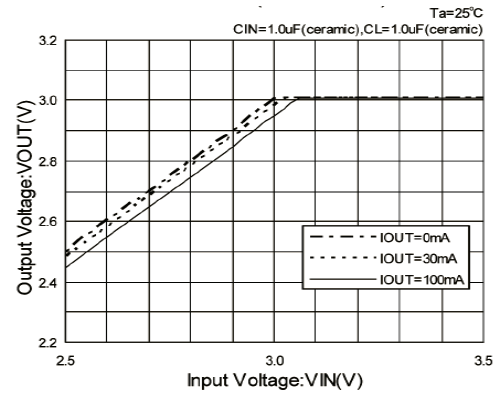
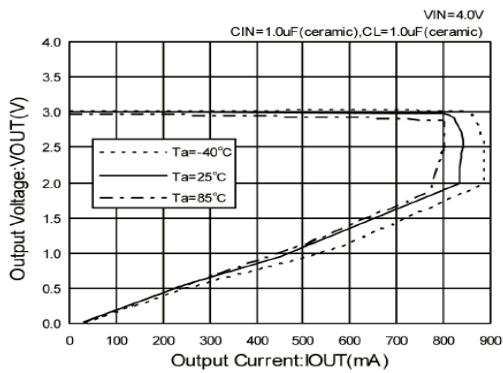

### 3. Dropout Voltage vs. Output Current

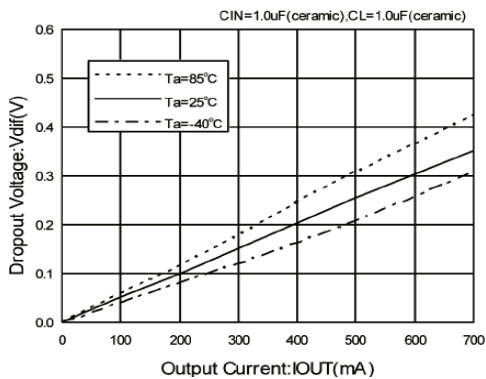

### 4. Supply Current vs. Supply Voltage

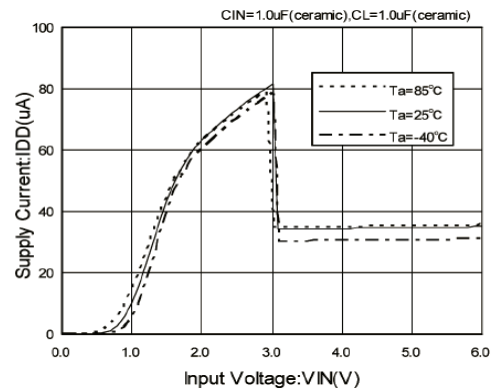

### 2. Output Voltage vs. Input Voltage (Contd.)

### 5. Output Voltage vs. Ambient Temperature

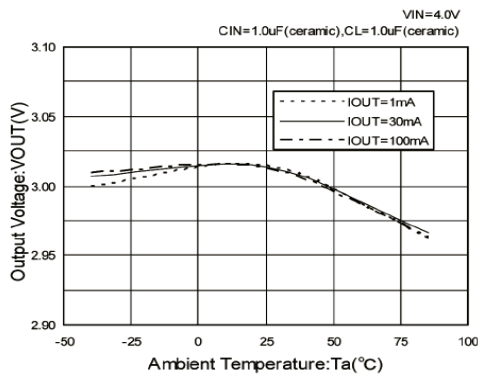

### 6. Ripple Rejection Rate

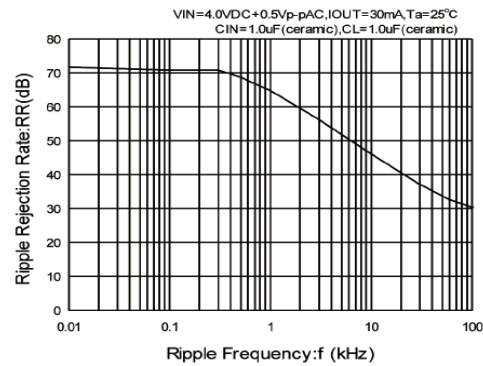

### 7. Transient Response

#### Input Transient Response

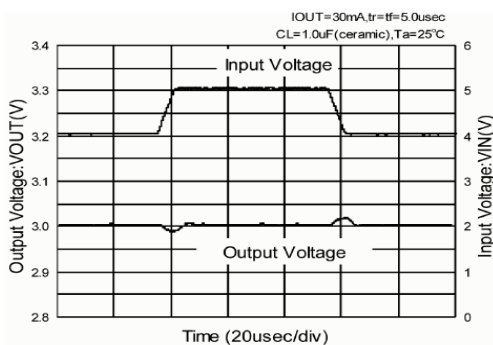

#### Load Transient Response

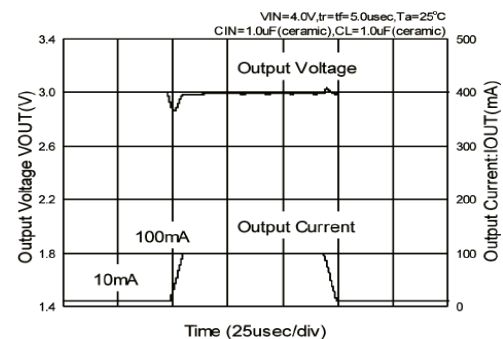

■ Package Information

- SOT-23-5L

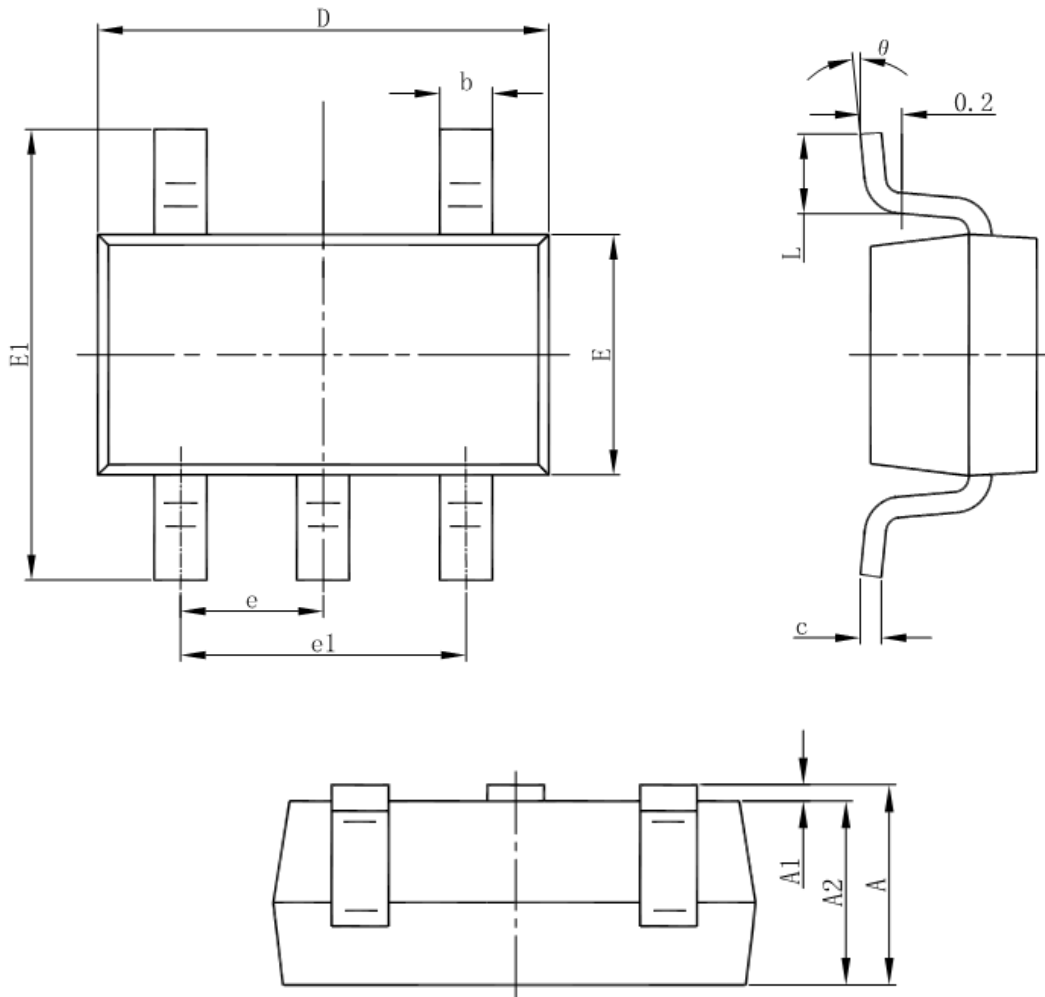

Symbol	Dimensions In Millimeters		Dimensions In Inches	
	Min	Max	Min	Max
A	1.050	1.250	0.041	0.049
A1	0.000	0.100	0.000	0.004
A2	1.050	1.150	0.041	0.045
b	0.300	0.500	0.012	0.020
c	0.100	0.200	0.004	0.008
D	2.820	3.020	0.111	0.119
E	1.500	1.700	0.059	0.067
E1	2.650	2.950	0.104	0.116
e	0.950(BSC)		0.037(BSC)	
e1	1.800	2.000	0.071	0.079
L	0.300	0.600	0.012	0.024
θ	0°	8°	0°	8°



● DFNWB1.8×2-6L

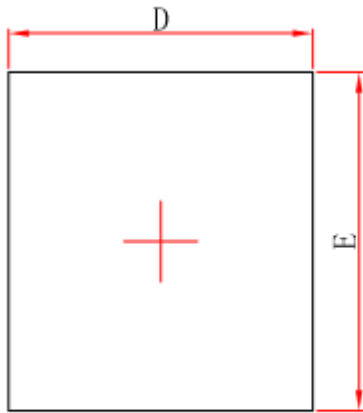

Top View

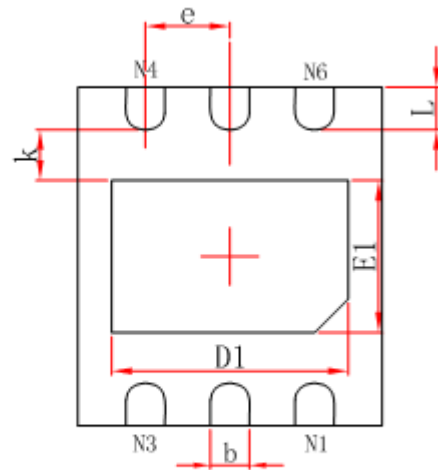

Bottom View

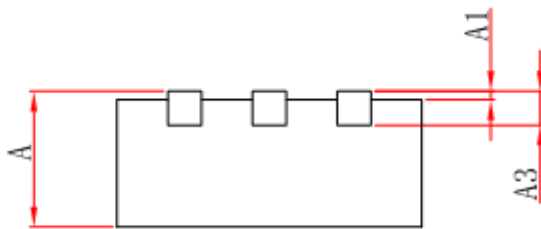

Side View

Symbol	Dimensions In Millimeters		Dimensions In Inches	
	Min.	Max.	Min.	Max.
A	0.450/0.550	0.550/0.650	0.018/0.022	0.022/0.026
A1	0.000	0.050	0.000	0.002
A3	0.150REF.		0.006REF.	
D	1.724	1.876	0.068	0.074
E	1.924	2.076	0.076	0.082
D1	1.300	1.500	0.051	0.059
E1	0.800	1.000	0.031	0.039
k	0.200MIN.		0.008MIN.	
b	0.180	0.280	0.007	0.011
e	0.500TYP.		0.020TYP.	
L	0.174	0.326	0.007	0.013

- SOT-89-5L

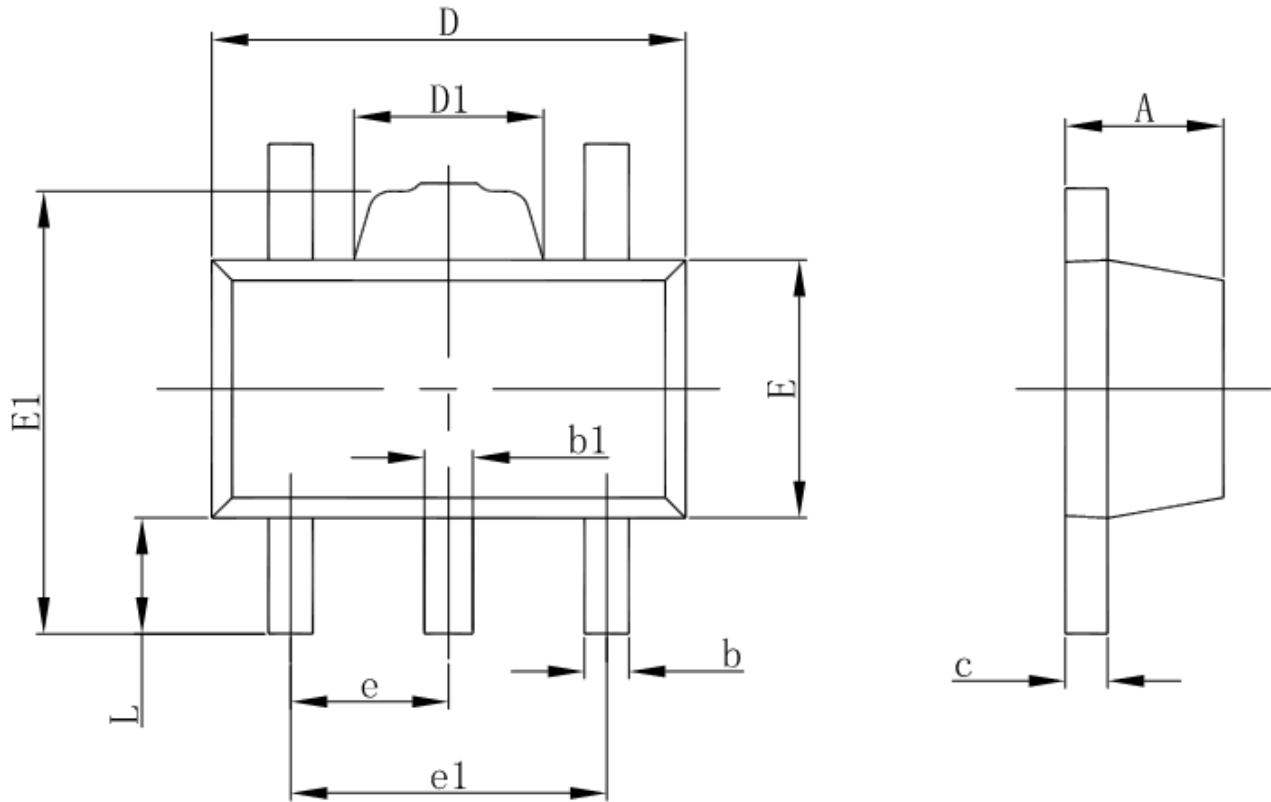

Symbol	Dimensions In Millimeters		Dimensions In Inches	
	Min.	Max.	Min.	Max.
A	1.400	1.600	0.055	0.063
b	0.320	0.520	0.013	0.020
b1	0.360	0.560	0.014	0.022
c	0.350	0.440	0.014	0.017
D	4.400	4.600	0.173	0.181
D1	1.400	1.800	0.055	0.071
E	2.300	2.600	0.091	0.102
E1	3.940	4.250	0.155	0.167
e	1.500TYP.		0.060TYP.	
e1	2.900	3.100	0.114	0.122
L	0.900	1.100	0.035	0.043