

Ultra Low Power Low Dropout Middle Current Voltage Regulators

General Description

The LN6218 series are precise, low power consumption, high voltage; positive voltage regulators manufactured using CMOS and laser trimming technologies. The series provides large currents with a significantly small dropout voltage. The LN6218 consists of a current limiter circuit, a driver transistor, a precision reference voltage and an error correction circuit. The series is compatible with low ESR ceramic capacitors. The current limiter's feedback circuit also operates as a short protect for the output current limiter and the output pin. Output voltage can be set internally by laser trimming technologies. It is selectable in 100mV increments within a range of 1.2V to 5.0V. SOT-89-3, SOT-23-3L packages are available.

Package

- SOT-89-3
- SOT-23-3L

Ordering Information

LN6218P ①②③④⑤

Designator	Symbol	Description	Designator	Symbol	Description
① ②	Integer	Output Voltage: e.g. ①=3, ②=0 ⇒ 3.0V	④	P	SOT-89-3
③	2	Accuracy: within ±2%	⑤	R	Embossed Tape: standard Feed
④	M	Package SOT-23-3		L	Embossed Tape: reverse Feed

Pin Configuration

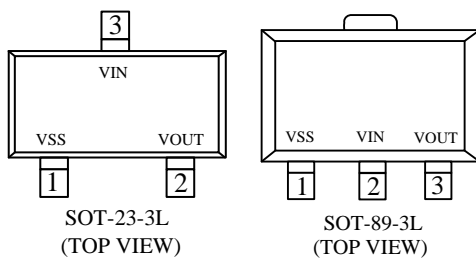

Pin number		Pin Name	Function
SOT-23-3L	SOT-89-3L		
3	2	VIN	Power Supply
1	1	VSS	Ground
2	3	VOUT	Output Pin

Features

- Output voltage range: 1.2V to 5.0V (selectable in 100mV steps)
- Highly optional accurate: ±2%
- Dropout voltage: 160mV @ 50mA (3.0V type)
- Low power consumption: 1μA (TYP.)
- Maximum output current: 250mA ($V_{in} \geq V_{out} + 1V$)
- Internal protector current limiter and short protector
- Small packages : SOT-89-3, SOT-23-3L and other required

Applications

- Battery powered equipment
- Reference voltage sources
- Cameras, video cameras
- Mobile phones
- Communication tools

Marking Rule

- SOT-89 -3 and SOT-23L

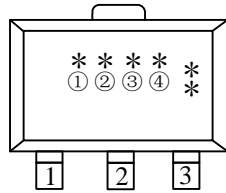

SOT-89-3L
(Top View)

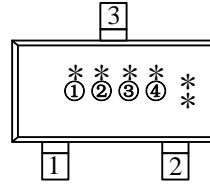

SOT-23-3L
(Top View)

- ① Represents product series

Symbol	Product Series
6	LN6218P◆◆◆◆◆

- ② Represents the type of regulator

Voltage(V)	0.1~3.0	3.1~5.0
±2%	E	F

- ③ Represents the Output Voltage

Symbol	Output Voltage (V)			Symbol	Output Voltage (V)		
0	-	3.1	-	F	1.6	4.6	-
1	-	3.2	-	H	1.7	4.7	-
2	-	3.3	-	K	1.8	4.8	-
3	-	3.4	-	L	1.9	4.9	-
4	-	3.5	-	M	2	5.0	-
5	-	3.6	-	N	2.1		-
6	-	3.7	-	P	2.2		-
7	-	3.8	-	R	2.3		-
8	-	3.9	-	S	2.4		-
9	-	4	-	T	2.5		-
A	-	4.1	-	U	2.6		-
B	1.2	4.2	-	V	2.7		-
C	1.3	4.3	-	X	2.8		-
D	1.4	4.4	-	Y	2.9		-
E	1.5	4.5	-	Z	3		-

- ④ and “*” Represents the assembly lot no.

Function Block Diagram

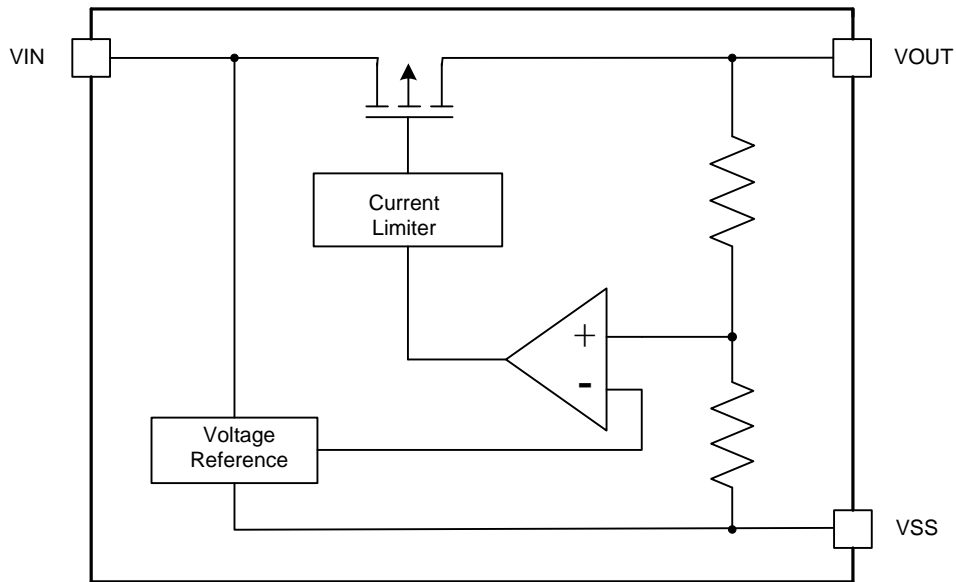

Absolute Maximum Ratings

Parameter	Symbol	Maximum Rating		Unit
Input Voltage	V_{IN}	$V_{SS}-0.3 \sim V_{SS}+6$		V
Output Current	V_{OUT}	$V_{SS}-0.3 \sim V_{IN}+0.3$		
Power Dissipation	P_D	SOT-23-3L	250	mW
		SOT-89-3	500	
Operating Ambient Temperature	T_{opr}	-40 ~ +85		°C
Storage Temperature	T_{stg}	-40 ~ +125		
ESD(HBM)		4000		V

Caution: The absolute maximum ratings are rated values exceeding which the product could suffer physical damage. These values must therefore not be exceeded under any conditions.

Typical Application Circuit

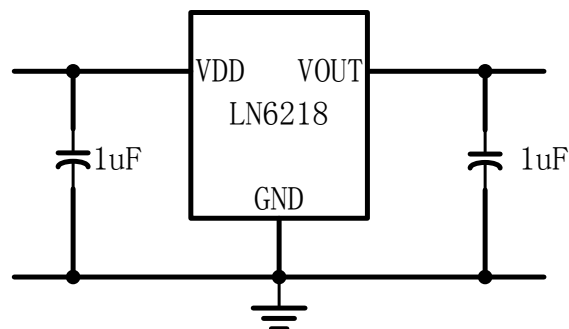

■ Application Conditions

Input capacitor (CIN): 1.0μF or more

Output capacitor (CL): 0.1 μF or more (tantalum capacitor)

Caution A general series regulator may oscillate, depending on the external components selected. Check that no oscillation occurs with the application using the above capacitor.

■ Electrical Characteristics

Item	Symbol	Condition	Min	Typ	Max	Unit	
Output Voltage	$V_{OUT(E)1}$	$V_{IN} = V_{OUT(S)} + 1.0 \text{ V}$, $I_{OUT} = 1 \text{ mA}$, $\pm 2\%$	$V_{OUT(S)}$ $\times 0.98$	$V_{OUT(S)}$	$V_{OUT(S)}$ $\times 1.02$	V	
Output Current	I_{OUT}	$V_{IN} \geq V_{OUT(S)} + 1.0 \text{ V}$	250^{*5}	—	—	mA	
Dropout Voltage	V_{drop}	$I_{OUT} = 50 \text{ mA}$	$1.5 \text{ V} \leq V_{OUT(S)} \leq 2.5 \text{ V}$	—	0.20	0.28	V
			$2.6 \text{ V} \leq V_{OUT(S)} \leq 3.3 \text{ V}$	—	0.16	0.24	
			$3.4 \text{ V} \leq V_{OUT(S)} \leq 5.0 \text{ V}$	—	0.12	0.20	
Line Regulations	$\frac{\Delta V_{OUT1}}{\Delta V_{IN} \cdot V_{OUT}}$	$V_{OUT(S)} + 0.5 \text{ V} \leq V_{IN} \leq 5.5 \text{ V}$ $I_{OUT} = 1 \text{ mA}$	—	0.05	0.2	%/V	
Input Voltage	ΔV_{OUT2}	$V_{IN} = V_{OUT(S)} + 1.0 \text{ V}$ $1.0 \text{ mA} \leq I_{OUT} \leq 50 \text{ mA}$	—	20	40	mV	
Output Voltage Temperature Characteristics	$\frac{\Delta V_{OUT}}{\Delta T_a \cdot V_{OUT}}$	$V_{IN} = V_{OUT(S)} + 1.0 \text{ V}$, $I_{OUT} = 10 \text{ mA}$ $-40^\circ\text{C} \leq T_a \leq 85^\circ\text{C}$	—	± 100	—	ppm/ °C	
Supply Current	I_{SS1}	$V_{IN} = V_{OUT(S)} + 1.0 \text{ V}$	—	1	2	μA	
Input Voltage	V_{IN}	—	1.8	—	6	V	
Ripple-Rejection	RR	$V_{IN} = V_{OUT(S)} + 1.0 \text{ V}$, $f = 1.0 \text{ kHz}$ $V_{rip} = 0.5 \text{ V}_{rms}$, $I_{OUT} = 10 \text{ mA}$	—	25	—	dB	
Short current	I_{short}	$V_{IN} = V_{OUT(S)} + 1.5 \text{ V}$,	—	30	—	mA	
Current Limiter	I_{lim}	$V_{IN} = V_{OUT(S)} + 1.5 \text{ V}$,	—	380	—	mA	

Typical Performance Characteristics (3.0V output)

1. Output Voltage vs. Output Current

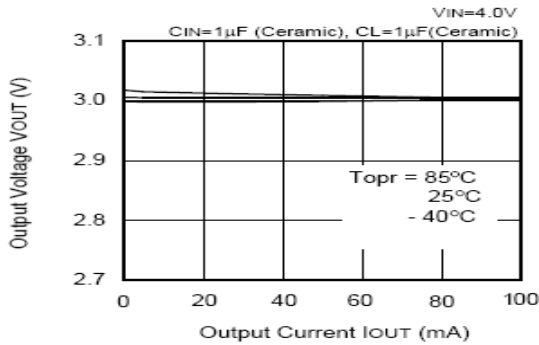

2. Output Voltage vs. Input Voltage

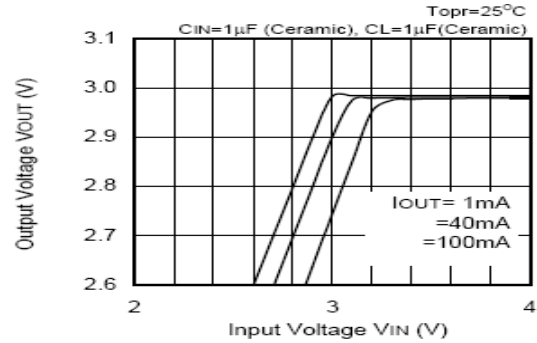

3. Dropout Voltage vs. Output Current

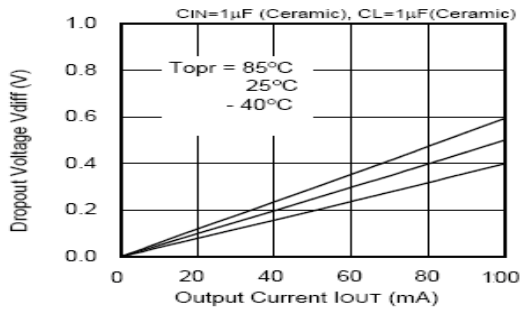

4. Dropout Voltage vs. Output Voltage

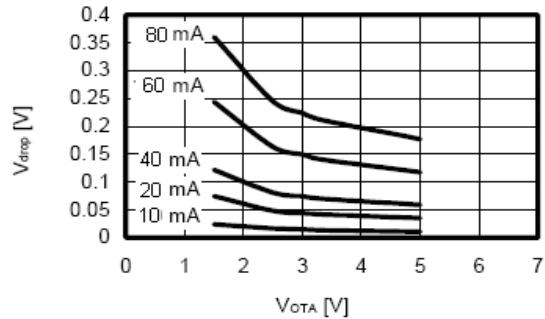

5. Output Voltage vs. Ambient Temperature

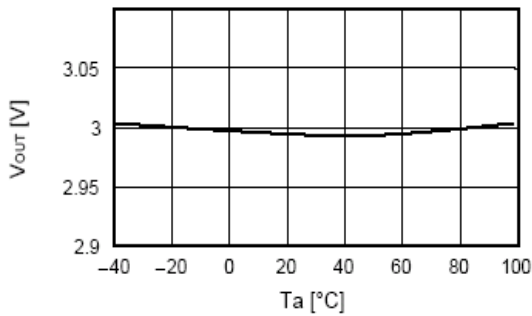

6. Ripple Rejection Rate

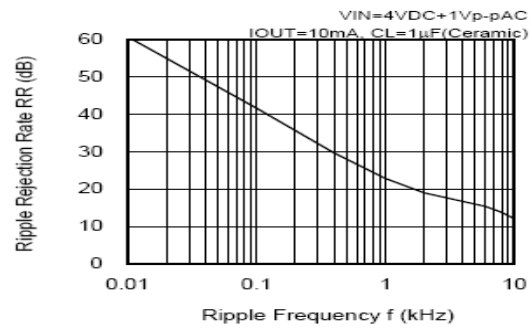

7. Transient Response

Input Transient Response

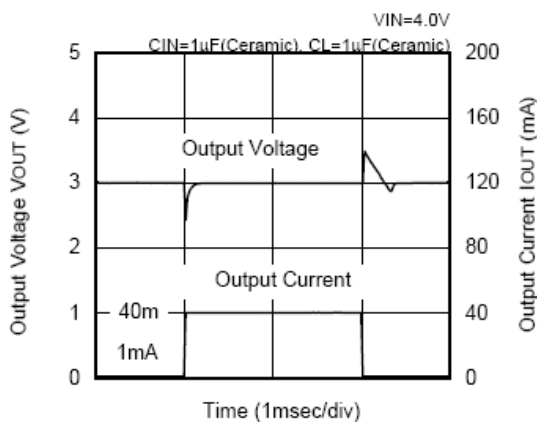

Load Transient Response

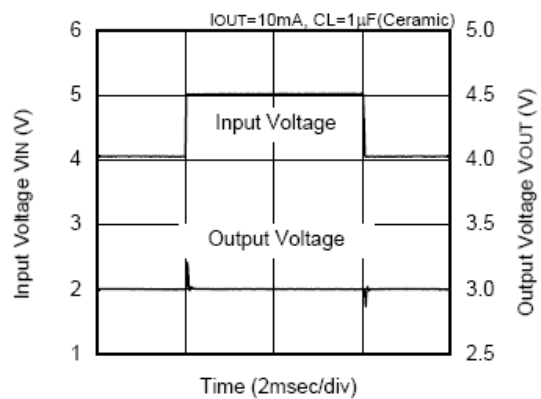

■ Packaging Information

- SOT-89-3

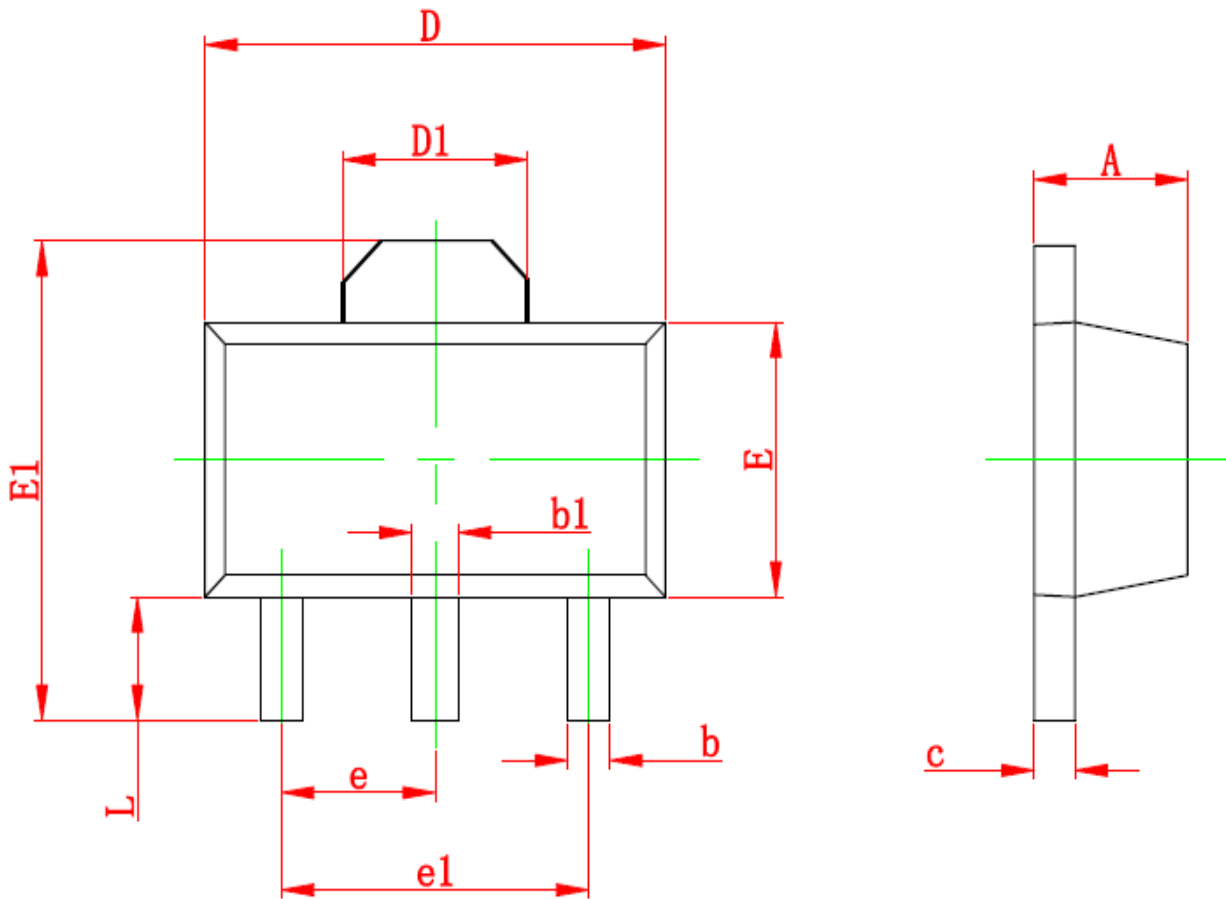

Symbol	Dimensions In Millimeters		Dimensions In Inches	
	Min	Max	Min	Max
A	1.400	1.600	0.055	0.063
b	0.320	0.520	0.013	0.197
b1	0.400	0.580	0.016	0.023
c	0.350	0.440	0.014	0.017
D	4.400	4.600	0.173	0.181
D1	1.550 REF		0.061 REF	
E	2.300	2.600	0.091	0.102
E1	3.940	4.250	0.155	0.167
e	1.500 TYP		0.060TYP	
e1	3.000 TYP		0.118TYP	
L	0.900	1.200	0.035	0.047

● SOT-23-3L

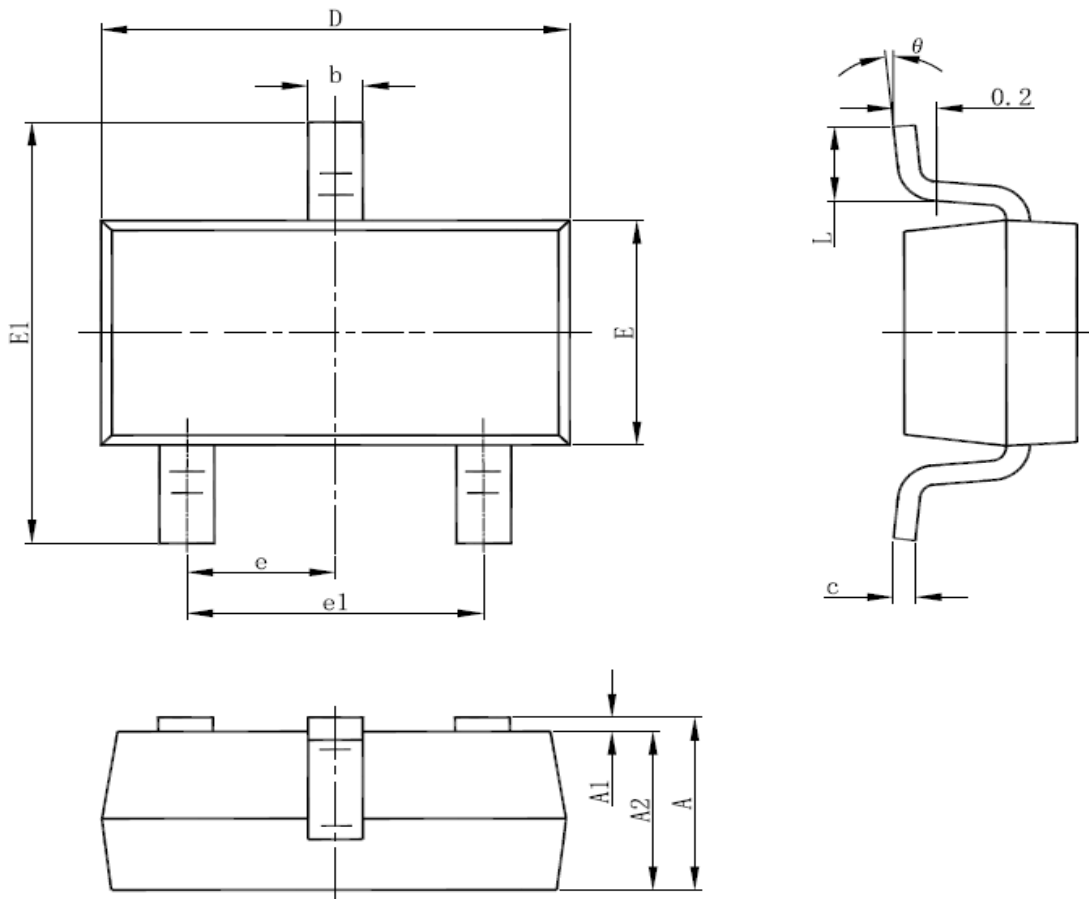

Symbol	Dimensions In Millimeters		Dimensions In Inches	
	Min	Max	Min	Max
A	1.050	1.250	0.041	0.049
A1	0.000	0.100	0.000	0.004
A2	1.050	1.150	0.041	0.045
b	0.300	0.500	0.012	0.020
c	0.100	0.200	0.004	0.008
D	2.820	3.020	0.111	0.119
E	1.500	1.700	0.059	0.067
E1	2.650	2.950	0.104	0.116
e	0.950(BSC)		0.037(BSC)	
e1	1.800	2.000	0.071	0.079
L	0.300	0.600	0.012	0.024
θ	0°	8°	0°	8°