

Tiny Package Low Dropout Current Source

■ General Description

The LN9306 low-dropout bias supply for white LEDs is a high-performance alternative to the simple ballast resistors used in conventional white LED designs. The LN9306 uses an internal resistor to set the bias current for six LEDs, which are matched to 3%. The LN9306's advantages over ballast resistors include much lower bias variation with supply voltage variation, significantly lower dropout voltage, and in some applications, significantly improved efficiency. The LN9306 requires a 60mV dropout at a 20mA load on each output to match the LED brightness.

The LN9306 is suitable for single cell Li-ion battery power device that using low forward voltage white LEDs. The white LEDs can be powered directly from battery without extra external components. This takes an advantage of highest efficiency and creates no EMI problem.

■ Applications

- Next-Generation wireless handsets
- PDAs, palmtops and handy terminals
- Digital cameras and camcorders
- Battery-powered equipment

■ Features

- Ultra low 60mV dropout at 20mA
- 3% High accuracy current matching
- 20mA full scale current
- PWM brightness control
- 2.5V to 5.5V supply voltage range
- Thermal shutdown protection
- Under-voltage protection

■ Package

- SOT-23-8
- DFN2×2-8

■ Ordering Information

LN9306 ①②③ (Eg: LN9306SRG)

Item	Symbol	Function
①	S	Denotes Package Type: SOT-23-8
	D	Denotes Package Type: DFN2×2-8
	*	Other special packaging
②	R	Embossed Tape :Standard Feed
	L	Embossed Tape :Reverse Feed
③	N	Normal package
	P	Pb Free package
	G	Green package

Pin Assignment

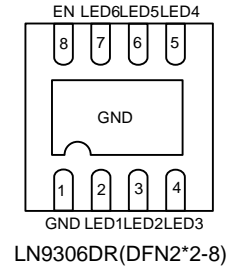
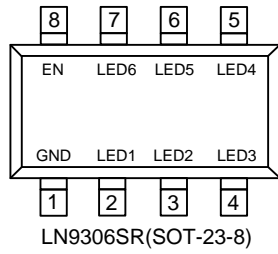

Pin Function Description

Pin Number	Pin Name	Function
1	GND	Ground
2	LED1	LED1 bias current input.
3	LED2	LED2 bias current input.
4	LED3	LED3 bias current input.
5	LED4	LED4 bias current input.
6	LED5	LED5 bias current input.
7	LED6	LED6 bias current input.
8	EN	Control pin, can input PWM or pulse signal

Function Block Diagram

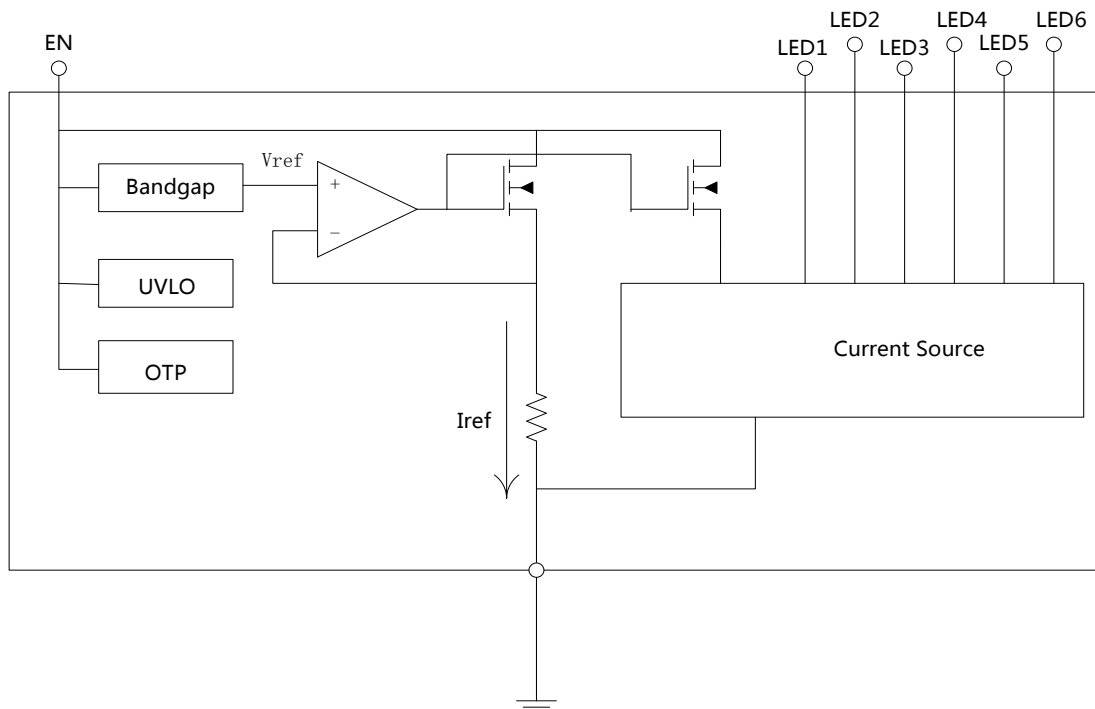

■ Absolute Maximum Ratings

(Ta=25°C)

Item	Symbol	Absolute maximum ratings	Unit
VIN to GND	V _{IN}	GND-0.3~7	V
EN to GND	V _{EN}	GND-0.3~V _{IN} +0.3	V
Power Dissipation	P _D	DFN2×2-8	1000
Operating Temperature range	Topr	-40~+85	°C
Storage Temperature range	Tstg	-65~+150	
Lead Temperature (Soldering, 10 sec.)	Tlead	260	

Caution: The absolute maximum ratings are rated values exceeding which the product could suffer physical damage. These values must therefore not be exceeded under any conditions.

■ Electrical Characteristics

VIN= 3.7V

(Ta=25°C, unless otherwise noted)

Parameter	Symbol	Test Condition	Min.	Typ.	Max.	Units
Input Supply Voltage	V _{IN}		2.5		5.5	V
Undervoltage Lockout Threshold	V _{UVLO}		-	2.1	-	V
UVLO Hysteresis			-	100	-	V
Shutdown Current	I _{SHDN}	EN<0.4V	-	-	1	μA
Quiescent Current	I _Q	I _{out} =0mA	-	450	-	μA
initial current	I _{LED}		18	20	22	mA
LED Pin Voltage Dropout	V _{LED-DROP}	V _{LED(DROP)} , 90% Max I _{LED}	-	60	-	mV
Current Matching				3	5	%
Thermal Shutdown Threshold				160		°C
Thermal Shutdown Hysteresis				10		°C
EN Pin Input Voltage High	V _{IH}	V _{EN} >V _{IH,ON}	2.5	-	-	V
EN Pin Input Voltage Low	V _{IL}	V _{EN} <V _{IL, OFF}	--	--	0.7	V

■ Typical Application Circuit

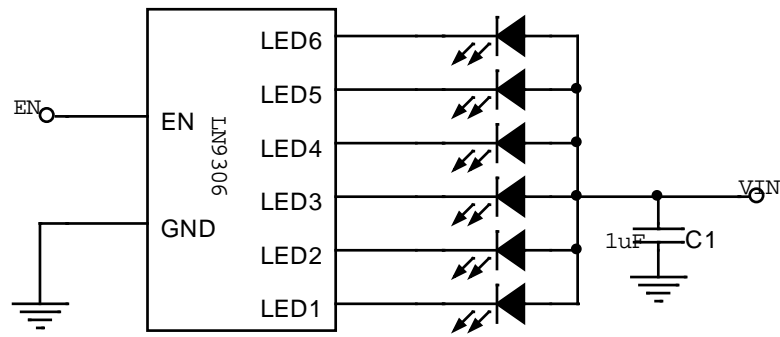

In the Figure, the capacitor is not required, LED pin will not connect when it will not use, EN as the power supply Pin, there must be enough current to drive, the drive current capacity of at least 500µA, effective voltage greater than 2.5V.

■ Package Information

- SOT-23-8

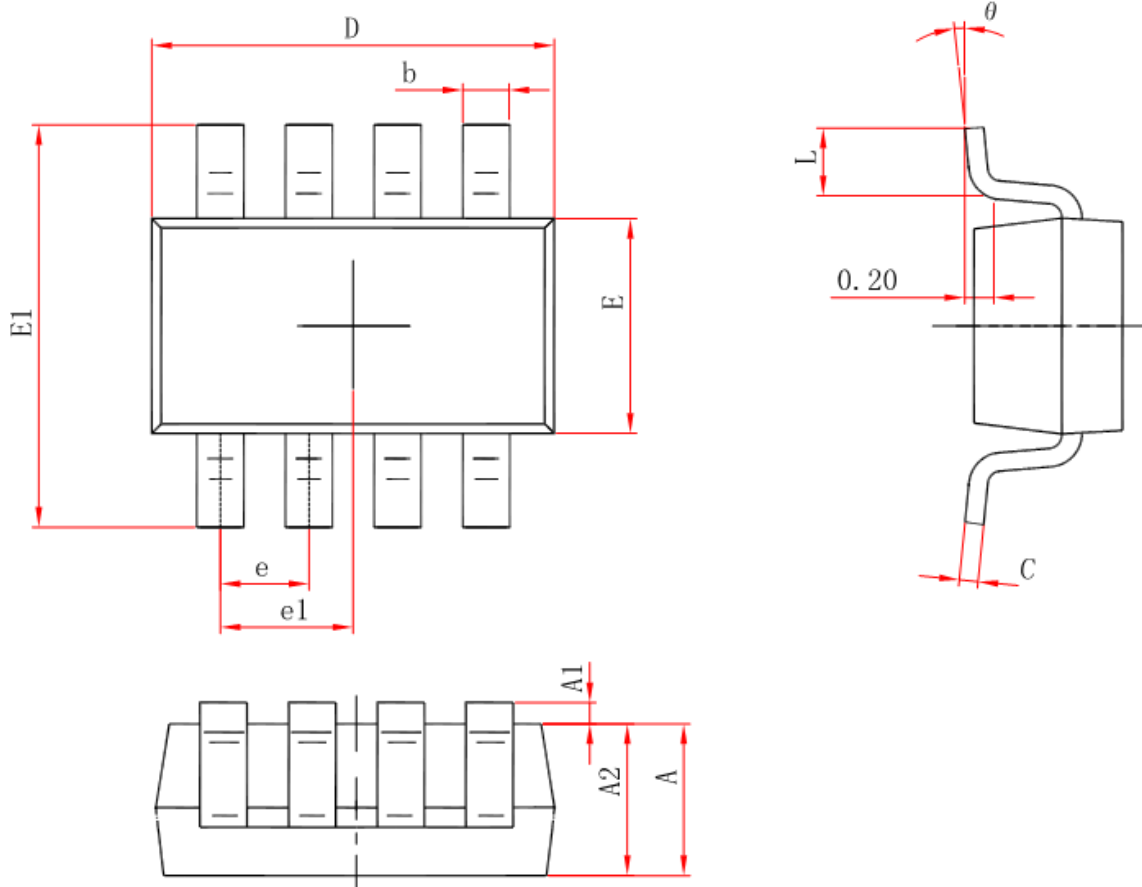

Symbol	Dimensions In Millimeters		Dimensions In Inches	
	Min	Max	Min	Max
A	1.050	1.250	0.041	0.049
A1	0.000	0.100	0.000	0.004
A2	1.050	1.150	0.041	0.045
b	0.300	0.500	0.012	0.020
c	0.100	0.200	0.004	0.008
D	2.820	3.020	0.111	0.119
E	1.500	1.700	0.059	0.067
E1	2.650	2.950	0.104	0.116
e	0.65 (BSC)		0.026(BSC)	
e1	0.975 (BSC)		0.038(BSC)	
L	0.300	0.600	0.012	0.024
θ	0°	8°	0°	8°

- DFN2×2-8

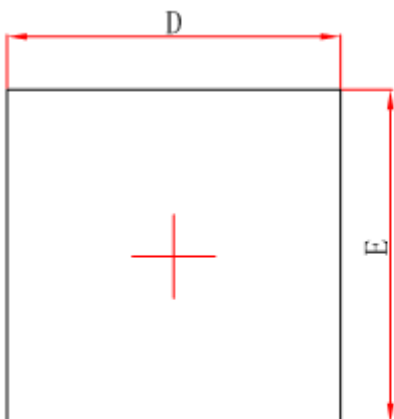

Top View

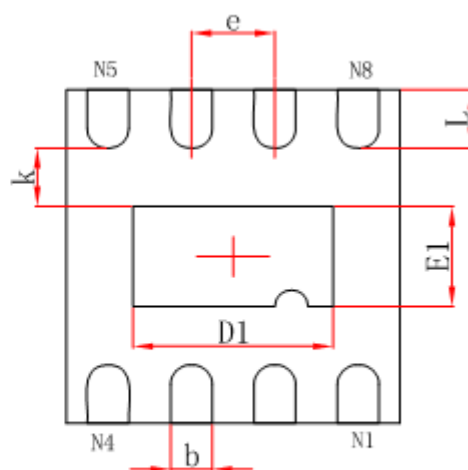

Bottom View

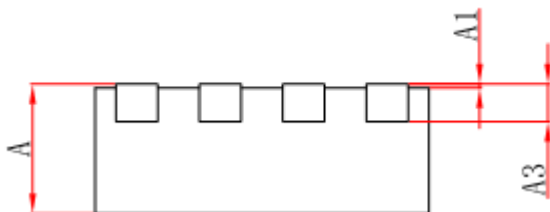

Side View

Symbol	Dimensions In Millimeters		Dimensions In Inches	
	Min.	Max.	Min.	Max.
A	0.700/0.800	0.800/0.900	0.028/0.031	0.031/0.035
A1	0.000	0.050	0.000	0.002
A3	0.203REF.		0.008REF.	
D	1.900	2.100	0.075	0.083
E	1.900	2.100	0.075	0.083
D1	1.100	1.300	0.043	0.051
E1	0.500	0.700	0.020	0.028
k	0.200MIN.		0.008MIN.	
b	0.180	0.300	0.007	0.012
e	0.500TYP.		0.020TYP.	
L	0.250	0.450	0.010	0.018