

80mA 4-Channel Charge Pump White LED Driver with Low Dropout Current Source

General Description

The LN9364 is a high performance white LED driver. It integrates current sources and automatic mode selection charge pump. The part maintains the high efficiency by utilizing an x1/x1.5 fractional charge pump and low dropout current sources. The small equivalent x1 mode open loop resistance and ultra-low dropout voltage of current source extend the operating time of x1 mode and optimize the efficiency of Li-ion battery in white LED applications.

The LN9364 supports up to 4 white LEDs and regulates a constant current for uniform intensity. The part implements a 4-bit DAC for brightness control. Users can easily configure the LED current from 1.25mA to 20mA by a serial pulse. The dimming of white LEDs current can be achieved by applying a pulse signal to the EN pin. There are totally 16 steps of current could be set by users. The operating voltage range is 2.7V to 5.5V. Internal soft start circuitry effectively reduces the in-rush current while both start-up and mode transition. The load is disconnected from VIN while shutdown and the shutdown current is less than 1 μ A.

Applications

- Mobile Phone, DSC, MP3
- White LED Backlighting
- LCD Display Supply

Features

- 90% average efficiency over battery life
- Support up to 4 white LEDs
- 80mV typical current source dropout
- Support up to 80mA output current
- 2% Typical LED current accuracy
- 1% Typical LED current matching
- Soft start function
- Auto charge pump mode selection
- 500kHz fixed frequency oscillator
- Output over voltage protection
- 16-Step brightness control
- Low input noise and EMI
- Low 1 μ A shutdown current

Package

- QFN3 \times 3-16

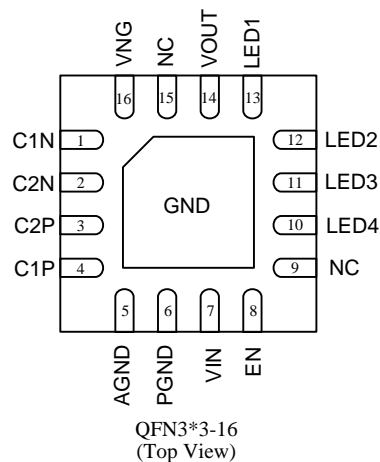

Ordering Information

Package	Marking	Symbol	Description
QFN3 \times 3-16	9364XXXX	LN9364-20	4 white LEDs, Each LED maximum current 20mA, Chip Enable (Active high)

Pin Function Description

Pin Number	Pin Name	Pin Function
1	C1N	Negative terminal of bucket capacitor 1
2	C2N	Negative terminal of bucket capacitor 2
3	C2P	Positive terminal of bucket capacitor 2
4	C1P	Positive terminal of bucket capacitor 1
5	AGND	Analog ground
6	PGND	Power ground.
7	VIN	Power input voltage
8	EN	Chip enable (Active High),and connects to GPIO pin of MCU
9,15	NC	No internal connection
10	LED4	Current sink for LED4.(If not in use ,pin should be connected to Vin)
11	LED3	Current sink for LED3.(If not in use ,pin should be connected to Vin)
12	LED2	Current sink for LED2.(If not in use ,pin should be connected to Vin)
13	LED1	Current sink for LED1.(If not in use ,pin should be connected to Vin)
14	VOUT	Output voltage source for LED1 to LED4.
16	VNG	Charge pump output
Exposed Pad	GND	Exposed pad should be soldered to PCB board and connected to gnd.

Function Block Diagram

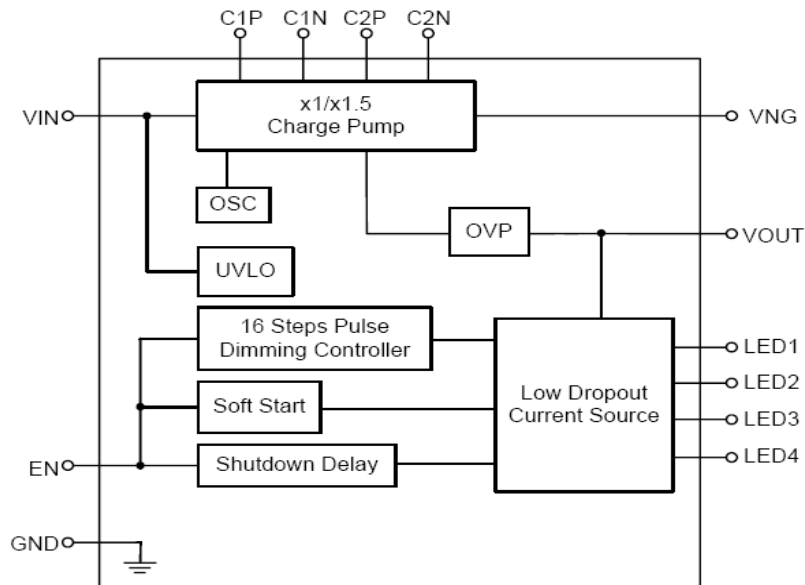

■ Absolute Maximum Ratings

(Ta=25°C)

Item	Symbol		Absolute maximum ratings	Unit
Input voltage	V _{IN}		-0.3~6.0	V
Output voltage	V _{OUT}		-0.3~6.0	V
En voltage	V _{EN}		-0.3~6.0	V
Power dissipation	P _D	QFN3x3-16	1.47	W
Package thermal resistance	θ _{JA}	QFN3x3-16	68	°C/W
Junction temperature	T _{jun}		150	°C
Operating Temperature range	T _{opr}		-40~+85	
Storage Temperature range	T _{stg}		-65~+150	
Lead Temperature (Soldering, 10 sec.)	T _{lead}		260	
ESD susceptibility	HBM(Human Body Mode)		3000	V
	MM(Machine Mode)		200	

Caution: The absolute maximum ratings are rated values exceeding which the product could suffer physical damage. These values must therefore not be exceeded under any conditions.

■ Electrical Characteristics

(Ta=25°C, unless otherwise noted)

Parameter	Symbol	Test Condition	Min.	Typ.	Max.	Units
Input supply voltage	V _{IN}		2.7		5.5	V
Undervoltage lockout threshold	V _{UVLO}	V _{IN} rising or falling	1.8	2.0	2.4	V
Undervoltage lockout hysteresis				100		mV
Shutdown current	I _{SHDN}	V _{IN} =4.2V, EN=LOW	-	1	10	μA
Quiescent of x1 Mode	I _{Qx1}	x1 Mode, V _{IN} = 5.5V, LED off		1		mA
I _{LED} accuracy	I _{LED-ERR}	2mA<I _{LED} <20mA		2	8	%
Current matching	I _{LED-LED-ERR}	2mA<I _{LED} <30mA		1	5	
x1 mode to x1.5 mode Transition voltage(vin falling)	V _{TRANS}	V _{LED} =3.4V, I _{LED1} =I _{LED2} =I _{LED3} =I _{LED4} =15mA		3.5		V
Oscillator frequency	F _{OSC}	V _{IN} -V _{OUT}		500K		HZ
Output over voltage protection	V _{OVp}			5.5	6	V
Thermal shutdown threshold				150		°C
Thermal shutdown hysteresis				10		°C
EN low time for shut down	T _{SHDN}		2			mS
EN low time for dimming	T _{LO}		0.5		500	μS
EN high time for dimming	T _{HI}		0.5			μS
En threshold logic-high voltage	V _{IH}		1.5			V
En threshold logic-low voltage	V _{IL}				0.4	V

Typical Application Circuit

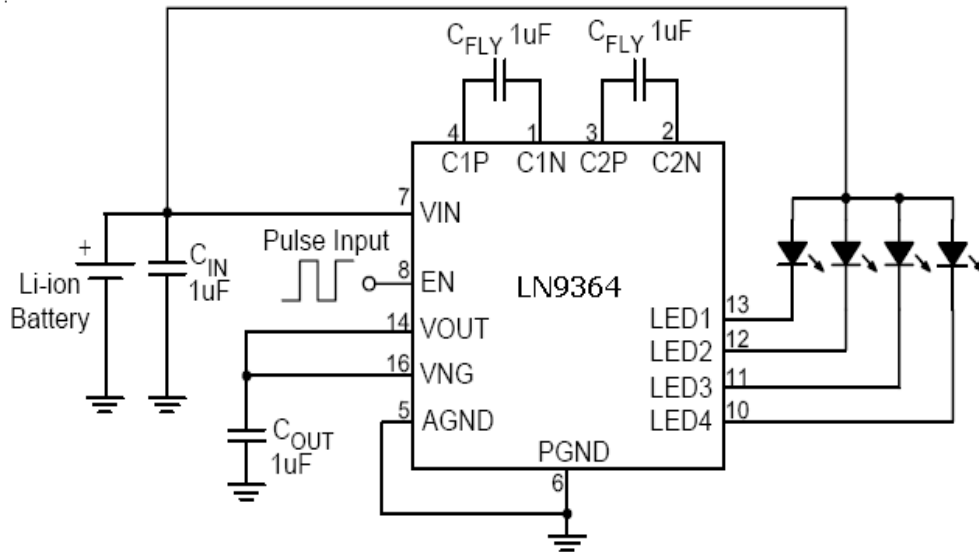

Figure 1. For 4-WLEDs Application Circuit

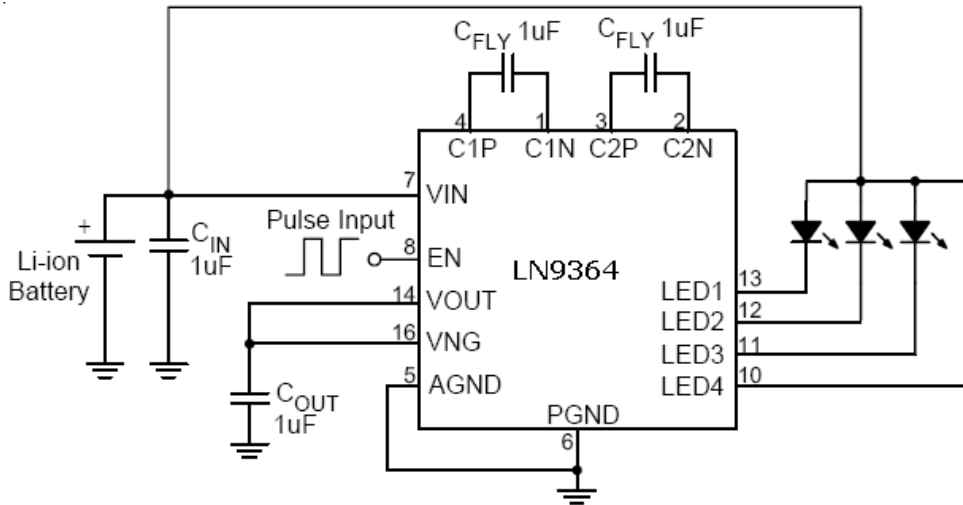

Figure 2. For 4-WLEDs Application Circuit

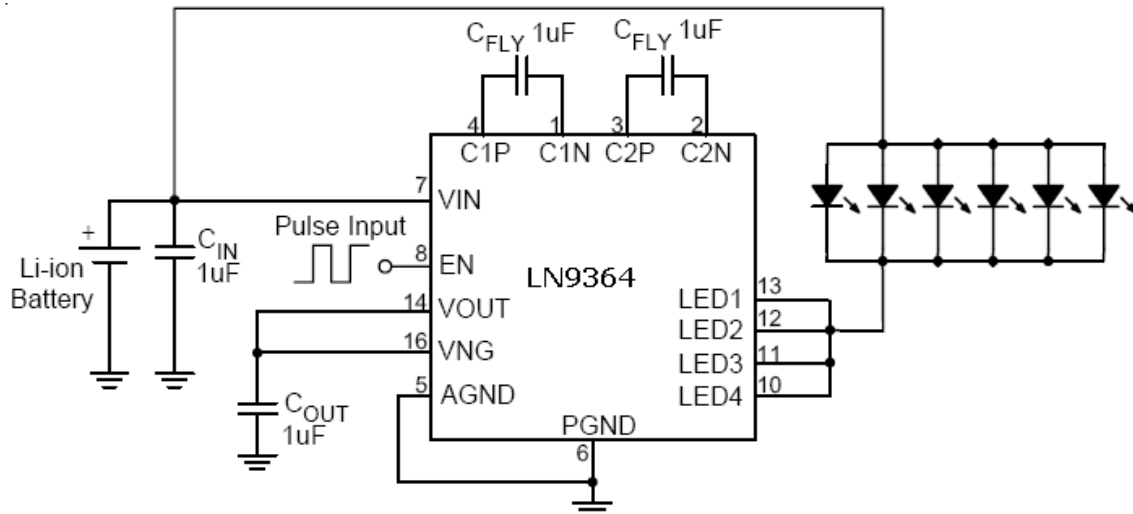

Figure 3. For more than 4-WLEDs Application Circuit

■ Operation

The LN9364 uses a fractional switched capacitor charge pump to power up to four white LEDs with a programmable current for uniform intensity. The part integrates current sources and automatic mode selection charge pump. It maintains the high efficiency by utilizing an x1/x1.5 fractional charge pump and current sources. The small equivalent x1 mode open loop resistance and ultra-low dropout voltage of current source extend the operating time of x1 mode and optimize the efficiency in white LED applications.

Brightness Control

The LN9364 implements a pulse dimming method to control the brightness of white LEDs. Users can easily configure the LED current from 1.25mA to 20mA by a serial pulse. The dimming of white LEDs' current can be achieved by applying a pulse signal to the EN pin. There are totally 16 steps of current could be set by users.

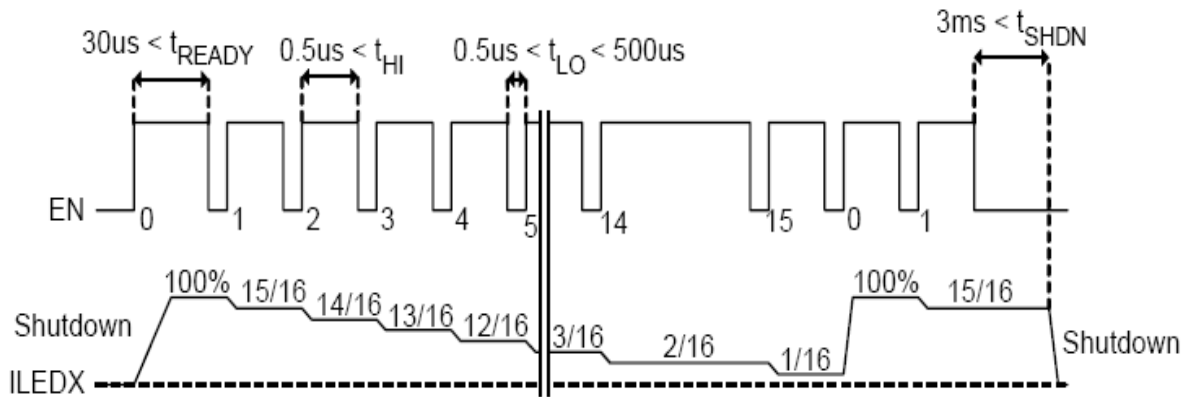

Figure 4. Brightness control by pulse dimming

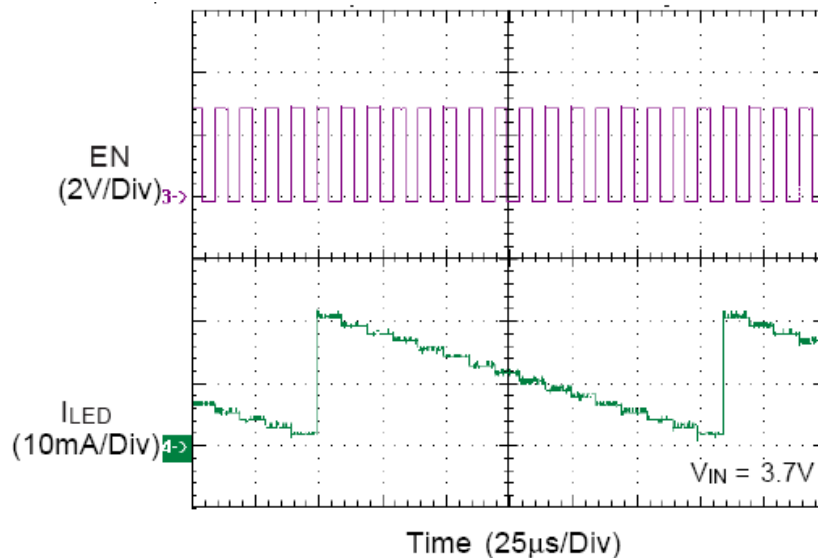

Figure 5. Examples of pulse adjust brightness

Mode Decision

The LN9364 uses a smart mode selection method to decide the working mode for optimizing the efficiency. Mode decision circuit senses the output and LED voltage for up/down selection. The LN9364 automatically switches to x1.5 mode whenever the dropout condition is detected from the current source and returns to x1 mode whenever the dropout condition releases.

LED connection

The LN9364 supports up to 4 white LEDs. The four LEDs are connected from VIN to pin 10, 11, 12 and 13 respectively. If the LED is not used, the LED pin should be connected to VIN directly.

Selecting Capacitors

To get the better performance of LN9364, the selection of peripherally appropriate capacitor and value is very important. These capacitors determine some parameters such as input/output ripple voltage, power efficiency, maximum supply current by charge pump. To reduce the input and output ripple effectively, the low ESR ceramic capacitors are recommended. For LED driver applications, the input voltage ripple is more important than output ripple. Input ripple is controlled by input capacitor CIN, increasing the value of input capacitance can further reduce the ripple. Practically, the input voltage ripple depends on the power supply impedance. The flying capacitor C1 and C2 determine the supply current capability of the charge pump and to influence the overall efficiency of system. The lower value will improve efficiency, but it will limit the LED's current at low input voltage.

■ Package Information

- QFN3×3-16

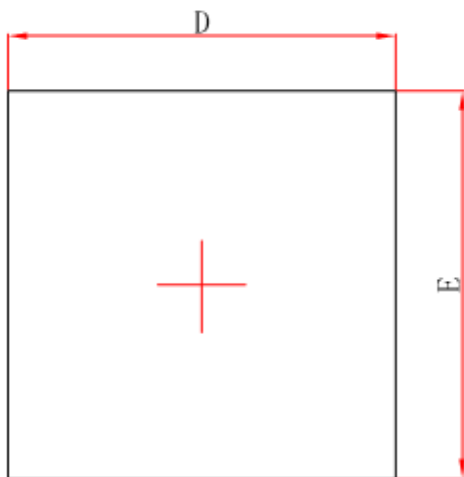

Top View

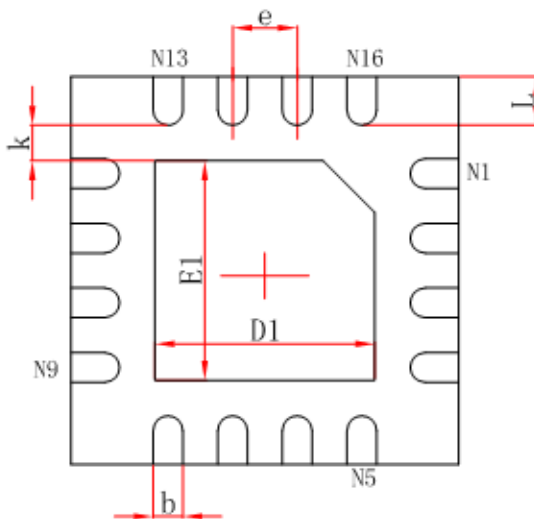

Bottom View

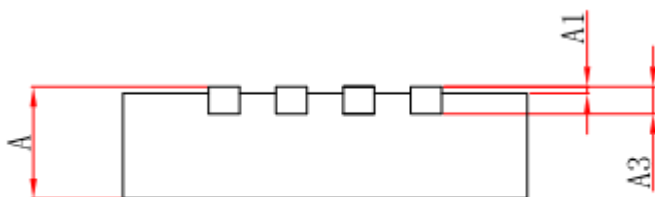

Side View

Symbol	Dimensions In Millimeters		Dimensions In Inches	
	Min.	Max.	Min.	Max.
A	0.700/0.800	0.800/0.900	0.028/0.031	0.031/0.035
A1	0.000	0.050	0.000	0.002
A3	0.203REF.		0.008REF.	
D	2.900	3.100	0.114	0.122
E	2.900	3.100	0.114	0.122
D1	1.600	1.800	0.063	0.071
E1	1.600	1.800	0.063	0.071
k	0.200MIN.		0.008MIN.	
b	0.180	0.300	0.007	0.012
e	0.500TYP.		0.020TYP.	
L	0.300	0.500	0.012	0.020