

Hi Power LEDs

www.DataSheet4U.com

LITEON® LOPL SMD SERIES

For quantities of 200 and up, call for quote.

MOUSER STOCK NO.	Lite-On Part No.	Fig.	Color	Wave-length (nm)	Luminous Flux (lm)	Power (W)	Voltage (VDC)	Current (A)	Price Each			
									1	10	50	100
1 Watt LEDs												
859-LOPL-E011M	LOPL-E011M	A	Warm White	3800K	28	1.5	3.8	0.35	4.63	3.79	3.40	3.07
859-LOPL-E011W	LOPL-E011W	A	Cool White	5500K	45	1.5	3.8	0.35	4.63	3.79	3.40	3.07
859-LOPL-E011R	LOPL-E011R	A	Red	625	37	1.15	2.57	0.35	3.80	3.11	2.79	2.52
859-LOPL-E011G	LOPL-E011G	A	Green	530	53	1.5	3.7	0.35	3.97	3.25	2.91	2.64
859-LOPL-E011B	LOPL-E011B	A	Blue	470	12	1.5	3.8	0.35	3.97	3.25	2.91	2.64
859-LOPL-E011MA	LOPL-E011MA	B	Warm White	3800K	28	1.5	3.8	0.35	4.96	4.06	3.64	3.29
859-LOPL-E011WA	LOPL-E011WA	B	Cool White	5500K	45	1.5	3.8	0.35	4.96	4.06	3.64	3.29
859-LOPL-E011RA	LOPL-E011RA	B	Red	625	37	1.15	2.57	0.35	5.13	4.20	3.76	3.40
859-LOPL-E011GA	LOPL-E011GA	B	Green	530	53	1.5	3.7	0.35	5.29	4.33	3.88	3.51
859-LOPL-E011BA	LOPL-E011BA	B	Blue	470	12	1.5	3.8	0.35	5.29	4.33	3.88	3.51
859-LOPL-E011MB	LOPL-E011MB	C	Warm White	3800K	28	1.5	3.8	0.35	4.96	4.06	3.64	3.29
859-LOPL-E011WB	LOPL-E011WB	C	Cool White	5500K	45	1.5	3.8	0.35	4.96	4.06	3.64	3.29
859-LOPL-E011RB	LOPL-E011RB	C	Red	625	37	1.15	2.57	0.35	5.13	4.20	3.76	3.40
859-LOPL-E011GB	LOPL-E011GB	C	Green	530	53	1.5	3.7	0.35	5.29	4.33	3.88	3.51
859-LOPL-E011BB	LOPL-E011BB	C	Blue	470	12	1.5	3.8	0.35	5.29	4.33	3.88	3.51
3 Watt LEDs												
859-LOPL-E033M	LOPL-E033M	A	Warm White	3800K	90	3.0	4.0	0.7	10.91	8.93	8.01	7.25
859-LOPL-E033W	LOPL-E033W	A	Cool White	5500K	120	3.0	4.0	0.7	10.91	8.93	8.01	7.25
859-LOPL-E033MA	LOPL-E033MA	B	Warm White	3800K	90	3.0	4.0	0.7	12.23	10.01	8.98	8.12
859-LOPL-E033WA	LOPL-E033WA	B	Cool White	5500K	120	3.0	4.0	0.7	12.23	10.01	8.98	8.12
859-LOPL-E033MB	LOPL-E033MB	C	Warm White	3800K	90	3.0	4.0	0.7	12.23	10.01	8.98	8.12
859-LOPL-E033WB	LOPL-E033WB	C	Cool White	5500K	120	3.0	4.0	0.7	12.23	10.01	8.98	8.12

SML SMD SERIES

For quantities of 200 and up, call for quote.

MOUSER STOCK NO.	Lumex Part No.	Fig.	Color	Wave-length (nm)	Luminous Flux (lm)	Power (W)	Voltage (VDC)	Current (A)	Price Each			
									1	10	50	100
696-SML-LX1610SIC	SML-LX1610SIC	D	Red	625	22	1.1	2.1	0.35	3.57	2.92	2.62	2.37
696-SML-LX1610SICA	SML-LX1610SICA	D	Red	625	22	1.1	2.1	0.35	3.57	2.92	2.62	2.37
696-SML-LX1610SYC	SML-LX1610SYC	D	Yellow	592	22	1.1	2.1	0.35	3.57	2.92	2.62	2.37
696-SML-LX1610SYCA	SML-LX1610SYCA	D	Yellow	592	22	1.1	2.1	0.35	3.57	2.92	2.62	2.37
696-SML-LX1610UPGC	SML-LX1610UPGC	D	Green	525	25	1.5	4	0.35	6.25	5.12	4.59	4.15
696-SML-LX1610UPGCA	SML-LX1610UPGCA	D	Green	525	25	1.5	4	0.35	6.25	5.12	4.59	4.15
696-SML-LX1610USBC	SML-LX1610USBC	D	Blue	470	5	1.5	3.5	0.35	6.25	5.12	4.59	4.15
696-SML-LX1610USBCA	SML-LX1610USBCA	D	Blue	470	5	1.5	3.5	0.35	6.25	5.12	4.59	4.15
696-SML-LX1610UWC	SML-LX1610UWC	D	White	---	30	1.5	3.5	0.35	6.25	5.12	4.59	4.15
696-SML-LX1610UWCA	SML-LX1610UWCA	D	White	---	30	1.5	3.5	0.35	6.25	5.12	4.59	4.15

OVSP SMD SERIES

For quantities of 200 and up, call for quote.

MOUSER STOCK NO.	Optek Part No.	Fig.	Color	Wave-length (nm)	Luminous Flux (lm)	Power (W)	Voltage (VDC)	Current (A)	Price Each			
									1	10	50	100
828-OVSPRBCR4	OVSPRBCR4	E	Red	625	26	1.2	2.5	0.4	1.98	1.62	1.46	1.32
828-OVSPYBCR4	OVSPYBCR4	E	Yellow	587	35	1.2	2.5	0.4	1.98	1.62	1.46	1.32
828-OVSPGBCR4	OVSPGBCR4	E	Green	530	48	1.2	3.6	0.35	4.96	4.06	3.64	3.29
828-OVSPBBCR4	OVSPBBCR4	E	Blue	470	9	1.2	3.6	0.35	3.30	2.70	2.42	2.19
828-OVSPWBCR4	OVSPWBCR4	E	White	---	48	1.2	3.6	0.35	3.60	2.94	2.64	2.39

OVTL SMD SERIES

For quantities of 200 and up, call for quote.

MOUSER STOCK NO.	Optek Part No.	Fig.	Color	Wave-length (nm)	Luminous Flux (lm)	Power (W)	Voltage (VDC)	Current (A)	Price Each			
									1	10	50	100
828-OVTL01LGARS	OVTL01LGARS	F	Red	625	53	1	2.3	350	2.88	2.35	2.11	1.91
828-OVTL01LGAAS	OVTL01LGAAS	F	Amber	595	38	1	2.3	350	2.88	2.35	2.11	1.91
828-OVTL01LGAGS	OVTL01LGAGS	F	Green	515	52	1	3.6	350	3.27	2.68	2.40	2.17
828-OVTL01LGABS	OVTL01LGABS	F	Blue	460	15	1	3.4	350	3.27	2.68	2.40	2.17
828-OVTL01LGAWS	OVTL01LGAWS	F	Cool White	---	50	1	3.4	350	3.47	2.84	2.55	2.31
828-OVTL01LGAWDS	OVTL01LGAWDS	F	Daylight White	---	45	1	3.4	350	3.47	2.84	2.55	2.31
828-OVTL01LGAWWS	OVTL01LGAWWS	F	Warm White	---	30	1	3.4	350	3.47	2.84	2.55	2.31

LEDNIUM SERIES

For quantities of 200 and up, call for quote.

MOUSER STOCK NO.	Optek Part No.	Fig.	Color	Wave-length (nm)	Luminous Flux (lm)	Power (W)	Voltage (VDC)	Current (A)	Price Each			
									1	10	50	100
828-OVTL09LGAR	OVTL09LGAR	G	Red	624	247	10	6.1	1.05	52.28	47.05	44.44	43.13
828-OVTL09LGAA	OVTL09LGAA	G	Amber	595	330	10	6.4	1.05	52.28	47.05	44.44	43.13
828-OVTL09LGAG	OVTL09LGAG	G	Green	524	290	10	9.9	1.05	62.40	56.16	53.04	51.48
828-OVTL09LGAB	OVTL09LGAB	G	Blue	467	60	10	9.1	1.05	57.34	51.61	48.74	47.31
828-OVTL09LGAW	OVTL09LGAW	G	White	5000K	250	10	9.1	1.05	66.14	59.53	56.22	54.57
828-OVTL09LGAM	OVTL09LGAM	G	RGB	---	221	10	8.6	1.05	57.34	51.61	48.74	47.31

SEOUL Z-POWER SMD SERIES

For quantities of 200 and up, call for quote.

MOUSER STOCK NO.	Seoul Part No.	Fig.	Color	Wave-length (nm)	Luminous Flux (lm)	Power (W)	Voltage (VDC)	Current (A)	Price Each			
									1	10	50	100
889-R92050	R92050	H	Red	625	14	0.7	2.5	0.2	1.93	1.42	1.27	1.15
889-A92050	A92050	H	Amber	590	18	0.7	2.5	0.2	1.93	1.42	1.27	1.15
889-B92050	B92050	H	Blue	460	5	0.7	3.5	0.2	1.93	1.42	1.27	1.15
889-W92050	W92050	H	Pure White	6500K	25	0.7	3.5	0.2	1.93	1.42	1.27	1.15
889-S92050	S92050	H	Natural White	4000K	20	0.7	3.5	0.2	1.93	1.42	1.27	1.15
889-N92050	N92050	H	Warm White	3000K	15	0.7	3.5	0.2	1.93	1.42	1.27	1.15

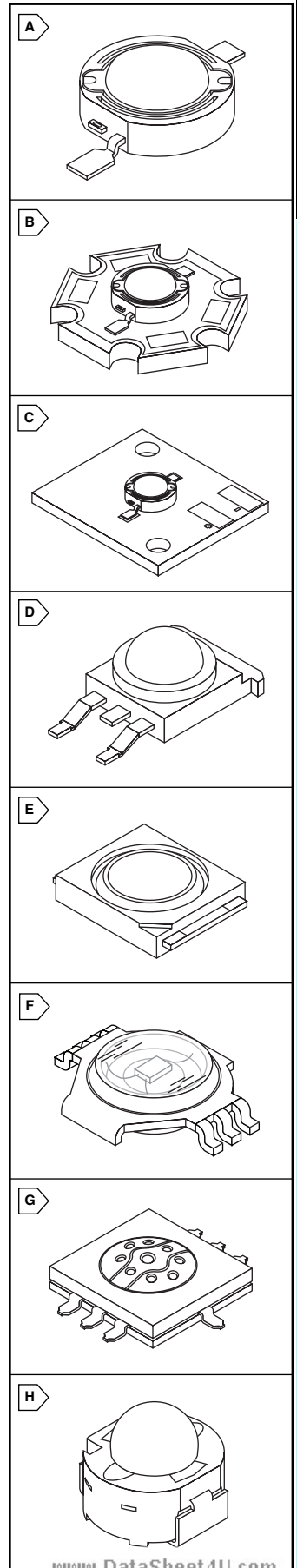

www.DataSheet4U.com

HI-POWER LEDs

NEW FROM SUPPLIER

NEW FROM SUPPLIER

NEW FROM SUPPLIER

NEW FROM SUPPLIER

HI-POWER LEDs

NEW FROM SUPPLIER

NEW FROM SUPPLIER

NEW FROM SUPPLIER

NEW FROM SUPPLIER