

TO: TOSHIBA CORPORATION

DATE: '10.08.11

Specification of 13.3" TFT/LCD
MODEL: LP133WH2 (TLM4)

Prepared	Checked	Approved	
K.Y.Kwon /Eng. Dept. /Engineer	Y.S.Ha /Eng. Dept. /Manager	Hans.Kim /Eng. Dept. /Senior Mgr	Brian Yoon /CS. Dept. /Senior Mgr

NOTICE of RECEIPT			
We accepted this specification. OME Operations, TOSHIBA Corp.			
Purchasing Dept.	Eng.	Senr. Eng.	Senr. Mgr
PC Hardware Dept.	Eng.	Senr. Eng.	Senr. Mgr

- CONTENTS -

Record of Revision	-----	4
1. Scope	-----	4
2. General Specifications	-----	4
2.1. Features		
2.2. Dimensional Outline		
3. Absolute Maximum Ratings	-----	9
3.1. Absolute Ratings of Environment		
3.2. Electrical Absolute Maximum		
3.3. Mechanical ratings		
3.4. The others		
4. Optical Characteristics	-----	16
4.1 Test Conditions		
4.2 Optical Specifications		
5. Electrical Characteristics	-----	21
5.1. TFT LCD module		
5.2. Backlight Unit		
5.3. Regulation		
6. Block Diagram	-----	25
7. Input Terminal Pin Assignment	-----	26
7.1 TFT LCD module		
7.2 Backlight Unit		
7.3 LVDS Transmitter		
7.4 Timing Diagrams of LVDS for Transmission		
7.5 Input Signal, Basic Display Colors and Gray Scale of Each Colors		
8. Interface timing	-----	31
8.1 Timing Parameters		
8.2 Timing diagrams of interface signal		
8.3 Power On / Off Sequence		
9. Cosmetic Specification	-----	33
9.1 Sampling		
9.2 Conditions of Inspections		
9.3 Defect modes		
9.4 Mechanical inspection		
9.5 Visual Inspection		
9.6 Electrical inspection		
10. Packing	-----	37
11. Labels and Other parts Exchange	-----	39
12. General Precaution	-----	47
Appendix	-----	49

Record of Revision

Date	Rev. No.	Sheet(New)	Item	Old	New	Reason
'10.4.9	0.0	All	-	-	-	First Edition
'10.5.17	0.1		Update Power Sequence (t4, t6)			
			Update Color Coordinate			
			Update Gray scale Spec.			
			Update Mechanical Drawing			
			Update EDID Data			
'10.6.11	0.2	All	New Format for Customer			
'10.6.28	0.3	30	Update Timing table			
'10.8.2	0.4	4	Update the LED Quantity	-	Add the LED Quantity	
		10	Update Connector tension test	"Backlight connector ~"	Delete the "Backlight connector ~"	
		30	Update Timing table	-	Add Refresh rate 40Hz	
		38	Update the Toshiba G-Code	G33C00067110	G33C00068110	
'10.8.11	0.5	25	Update the Connector maker			

1. Scope

This specification is applicable to LCD manufacturer's 13.3" diagonal size TFT-LCD module "LP133WH2(TLM4)" designed for Personal Computer.

2. General Specification

2.1. Features

Item	Specifications
Display area (Active area)	293.42(H, typ.) × 164.97 (V, typ.) (13.3 inches diagonal)
Driving Method	TFT active matrix
Number of Pixels	1366 (W) × 768 (H) × R,G,B (HD) (pixels) ¹⁾
Pixel pitch	0.2148mm × 0.2148 mm ¹⁾
Pixel Arrangement	RGB vertical stripes ¹⁾
Display color	262,144 (colors)
Display Mode	Transmissive mode, Normally white
Viewing Direction	6 o'clock (in direction of maximum contrast)
Surface Treatment	Anti-glare treatment of the front polarizer
Interface	LVDS
Backlight	Single light emitting diode for side-lighting (LED Quantity : 36ea)
Dimensional Outline	306.3±0.5 (H) × 177.7 ±0.5 (W) / 3.6(Max) (D) (mm)
Bezel Opening	297.42(H) × 168.57±0.5 (W) (mm)
Weight	290g (Typ.) / 300g (Max.)

Note 1)

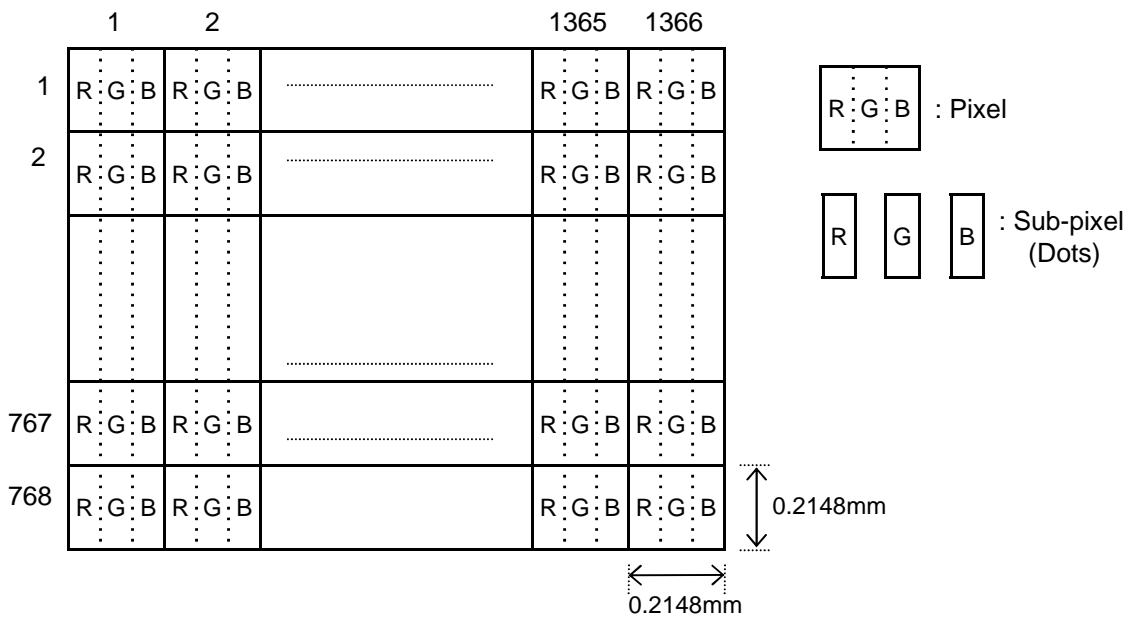

2.2. Dimensional Outline
(Front figure)

Note) Unit:[mm], General tolerance: $\pm 0.5\text{mm}$

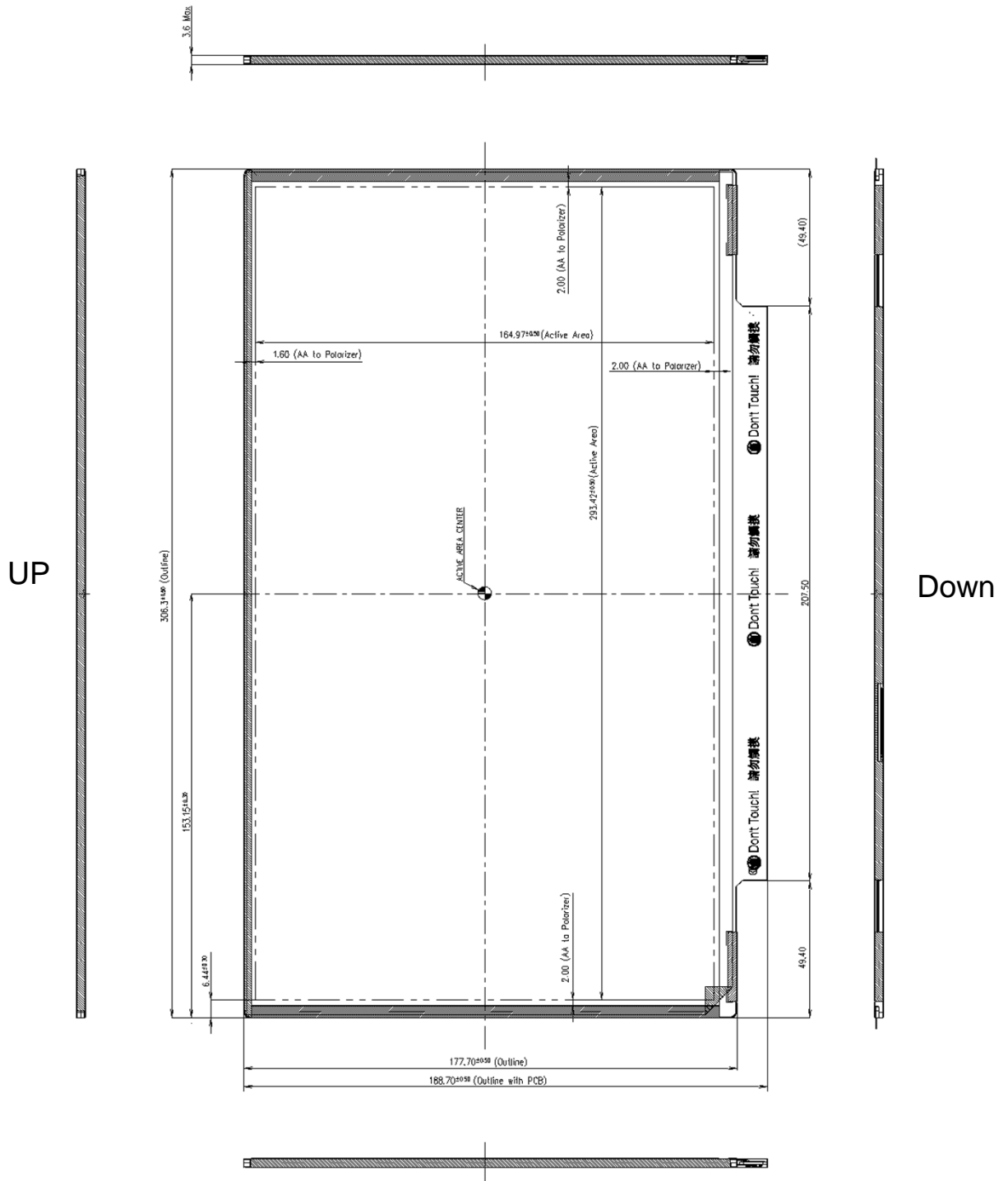

* The size that related with metal bezel includes tape thickness (0.05mm)

(Rear figure)

Note) Unit:[mm], General tolerance: ± 0.5mm

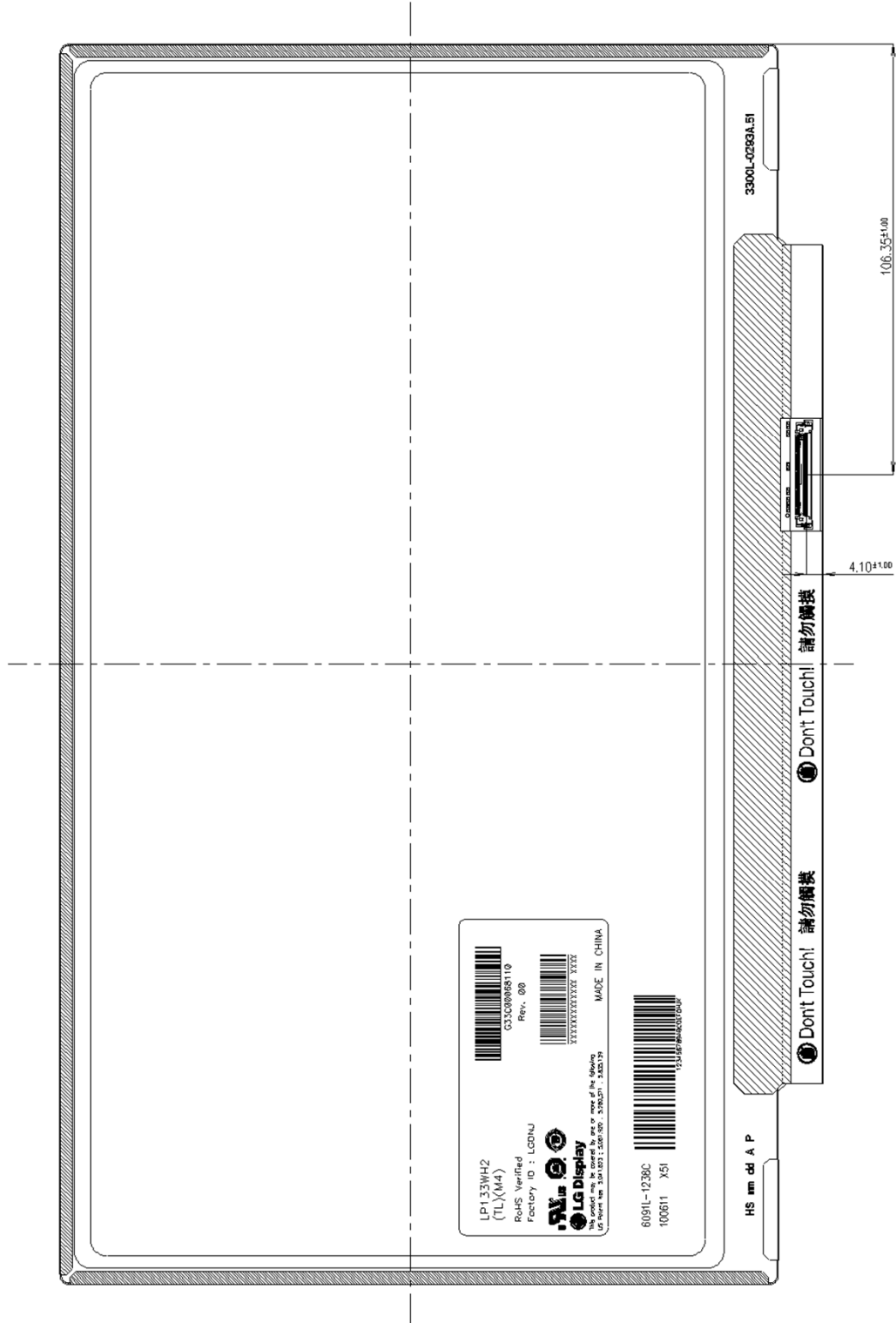

(Detail description of height of LCM back side & TAB Zone)

Note) Unit:[mm], General tolerance: ± 0.5mm

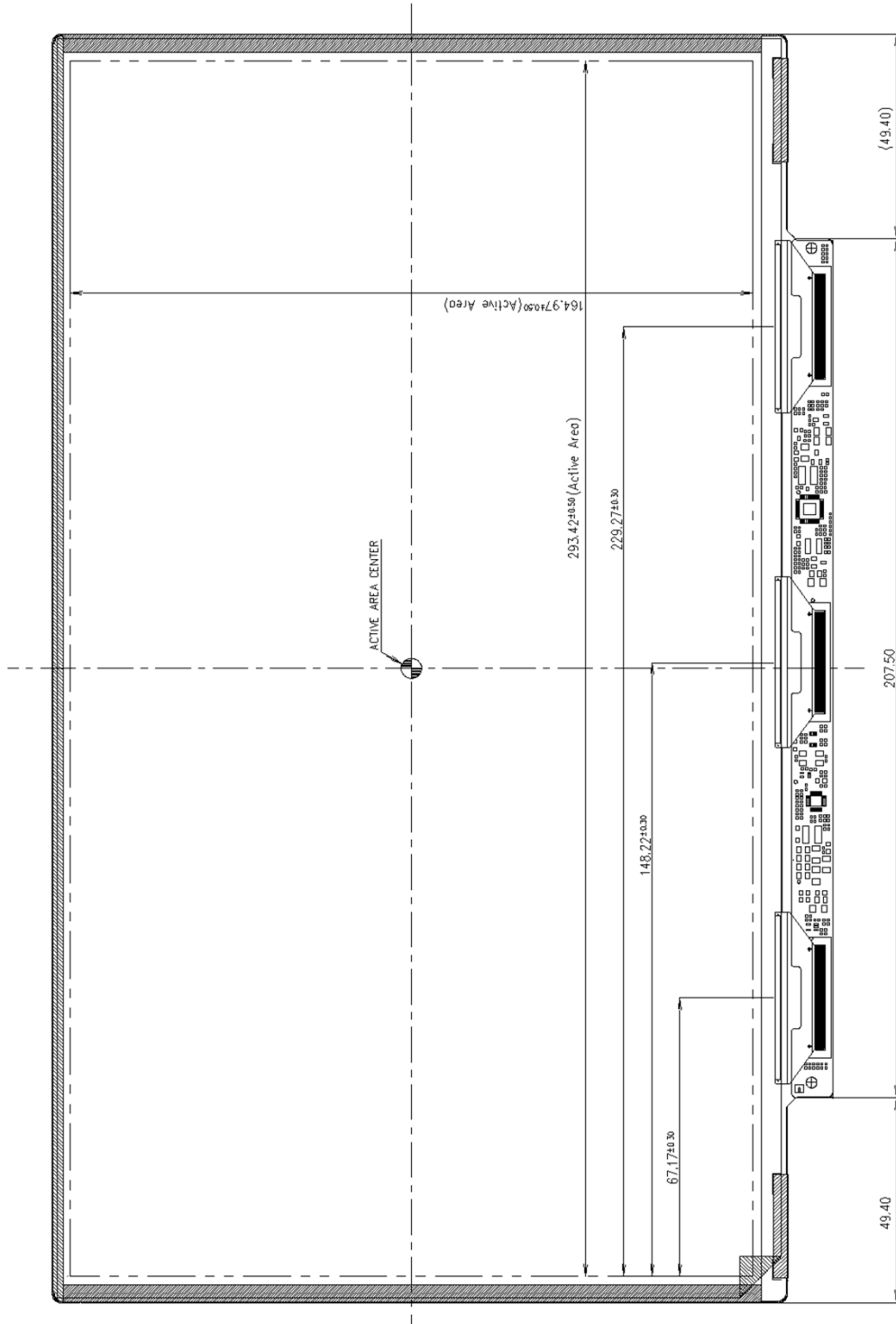

3. Absolute Maximum Ratings

3.1. Absolute Ratings of Environment

Item	Symbol	Min	Max	Unit	Note
Operating Ambient Temperature	TOP	0	+50	°C	(1)
Operating Temperature for Panel	-	0	+50	°C	(2)
Storage Temperature	TSTG	-20	+60	°C	(1)
Operating Ambient Humidity	HOP	10	90	%RH	(1)
Storage Humidity	HSTG	10	90	%RH	(1)
Air Pressure	-	57	101.3	kPa	Operation
Air Pressure	-	12	101.3	kPa	Non-operation
Altitude	-	-	3	Km	Operation
Altitude	-	-	12	Km	Non-operation

Note 1) Temperature and relative humidity range are shown in the figure below.

Wet bulb temperature should be 39°C Max, and no condensation of water.

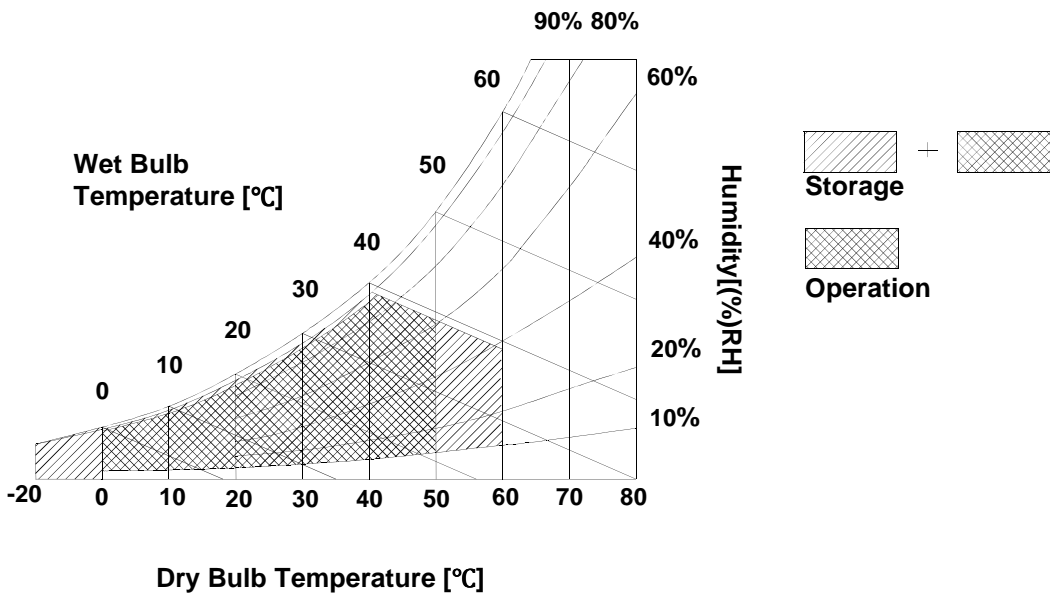

Note 2) The surface temperature caused by self heat radiation of cell itself is specified on this item.

3.2. Electrical Absolute Maximum

(1) TFT LCD Module

Item	Symbol	Min	Max	Unit	Note
Power Supply Voltage	V _{DD}	-0.3	+4.0	V	at 25 ± 5°C
Logic Input Voltage	V _{IN}	-0.3	V _{DD} +0.3	V	LVDS interface

(2) Back Light Unit

Item	Symbol	Min	Max	Unit	Note
LED Driver Supply Voltage	V _L	-0.3	23	V	damage to the device
LED PWM / LED_EN Voltage	V _{PWM} V _{LED_EN}	-0.3	6.0	V	

3.3. Mechanical Ratings

Test Item	Test Conditions	Note
Mechanical Vibration	Frequency Range 5 - 500 Hz, 14.7m/s ² (1.5G) constant, 0.5Hrs each axis (X, Y, Z direction).	Non Operation
	Frequency Range 5 - 500 Hz, 4.9m/s ² (0.5G) constant, 0.5Hrs each axis (X, Y, Z direction).	Operation
Mechanical Shock LCD fix condition -> See Note (2)	* 240G, Pulse width 2 ms, Sine Wave, ±X, ±Y, ±Z direction. 70G, Pulse width 11ms, Sine Wave ±X, ±Y, ±Z direction. * Note) Normal function is only checking points.	Non Operation
	98 m/s ² (10G), Pulse width 11 ms, Sine Wave, ±X, ±Y, ±Z direction.	Operation
Pressure Resistanace -> See Note (1)	No Destruction with the force 196 N (20 kgf, 16 mm in diameter) to the display surface at the vertical direction.	Non Operation Fig 1-1 Fig 1-2 Fig 1-3
	No Destruction with the force 294.2 N (30 kgf, 30 mm in diameter) to the back of the display surface at the vertical direction. Only the breakage of below items will not happen after test. (Glass.LED & Circuit parts)	
Connector tension test	Input connector : With 50 times of connector trial there must be no damage to the shape and functionally.	Non Operation
Assured torque value at side-mout part	M2 : Max 2.5 kgf	Non Operation
Rescrewed test	15 times under Max. torque	Non Operation
Tapping test	Tapping area : All bezel(Metal cover) side, LCD: Full-screen gray (L32). "Ripple (Pooling)" can not be seen in Active Area Tapping Force: Max 3kgf.cm	Operation

Definitions of failure for judgment shall be as follows:

- (1) Function of the module should be maintained.
- (2) Current consumption should be smaller than the specified value.
- (3) Appearance and display quality should not have distinguished degradation.
- (4) Luminance should be larger than the minimum value specified in optical specification.

Note 1)

(1) The compression condition of front side

(a) Compression point : 12 points (refer to Fig 1-1)

(b) Compression condition: 20kgf, 3 sec, Tool diameter: 16 mm in diameter (refer to Fig 1-3)

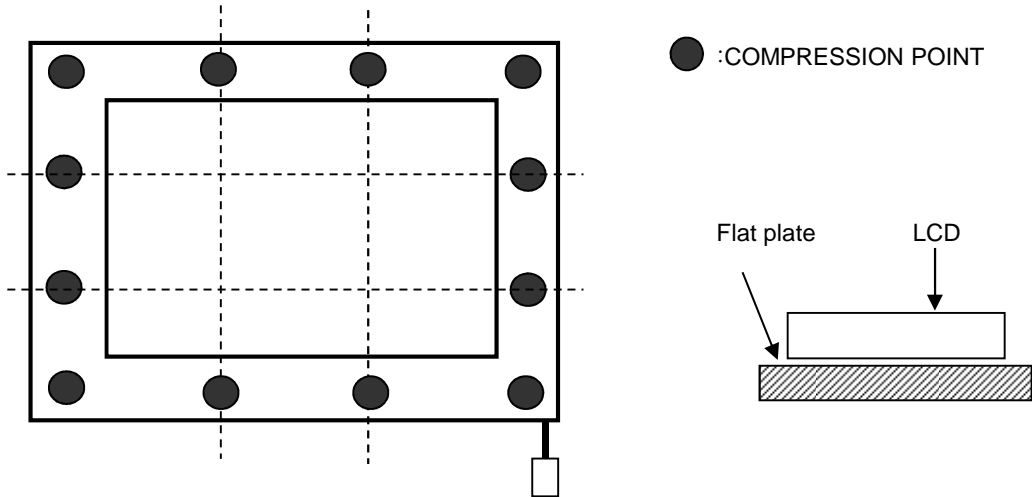

[Fig 1-1]

(2) The compression condition of rear side

(a) Compression point : 21 points (refer to Fig 1-2)

(b) Compression condition : 30kgf, 3 sec, Tool radius: 30 mm in diameter (refer to Fig 1-3)

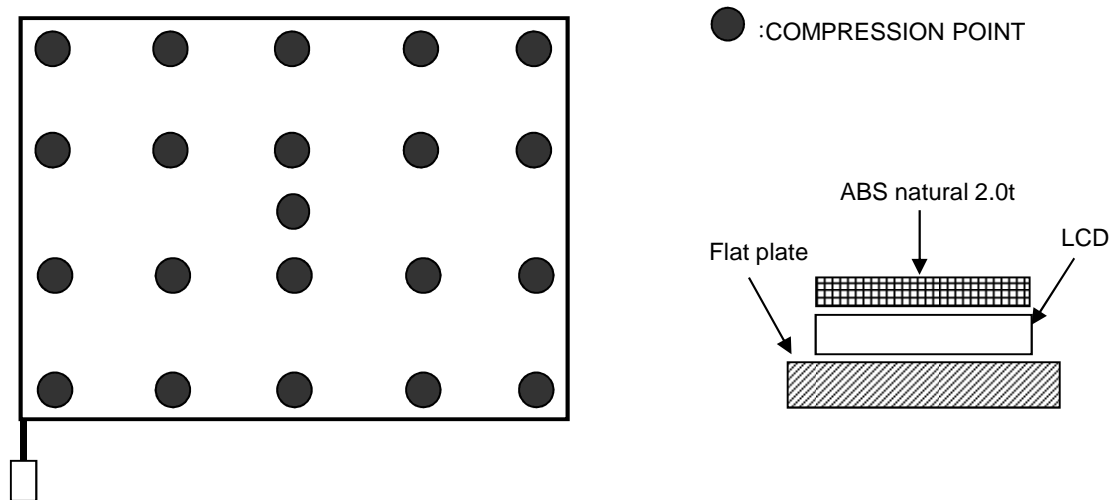

[Fig 1-2]

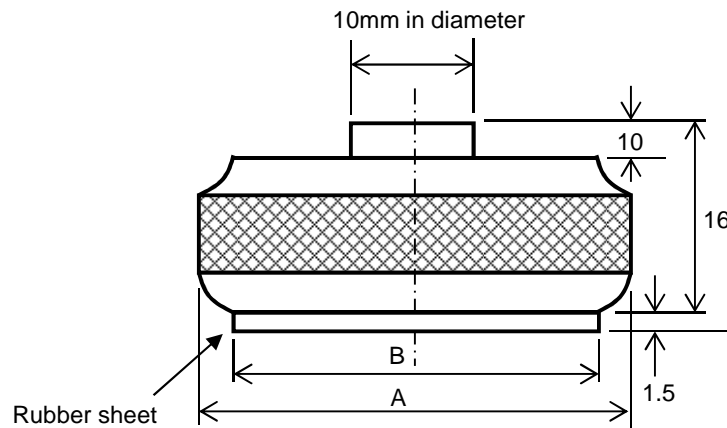

[Fig 1-3]

(3) Dimension of the compression jig

- (a) compression jig for front side A = 16 mm in diameter
B = 16 mm in diameter
- (b) compression jig for rear side A = 30 mm in diameter
B = 28 mm in diameter

Note 2) LCD fixing condition for z direction.

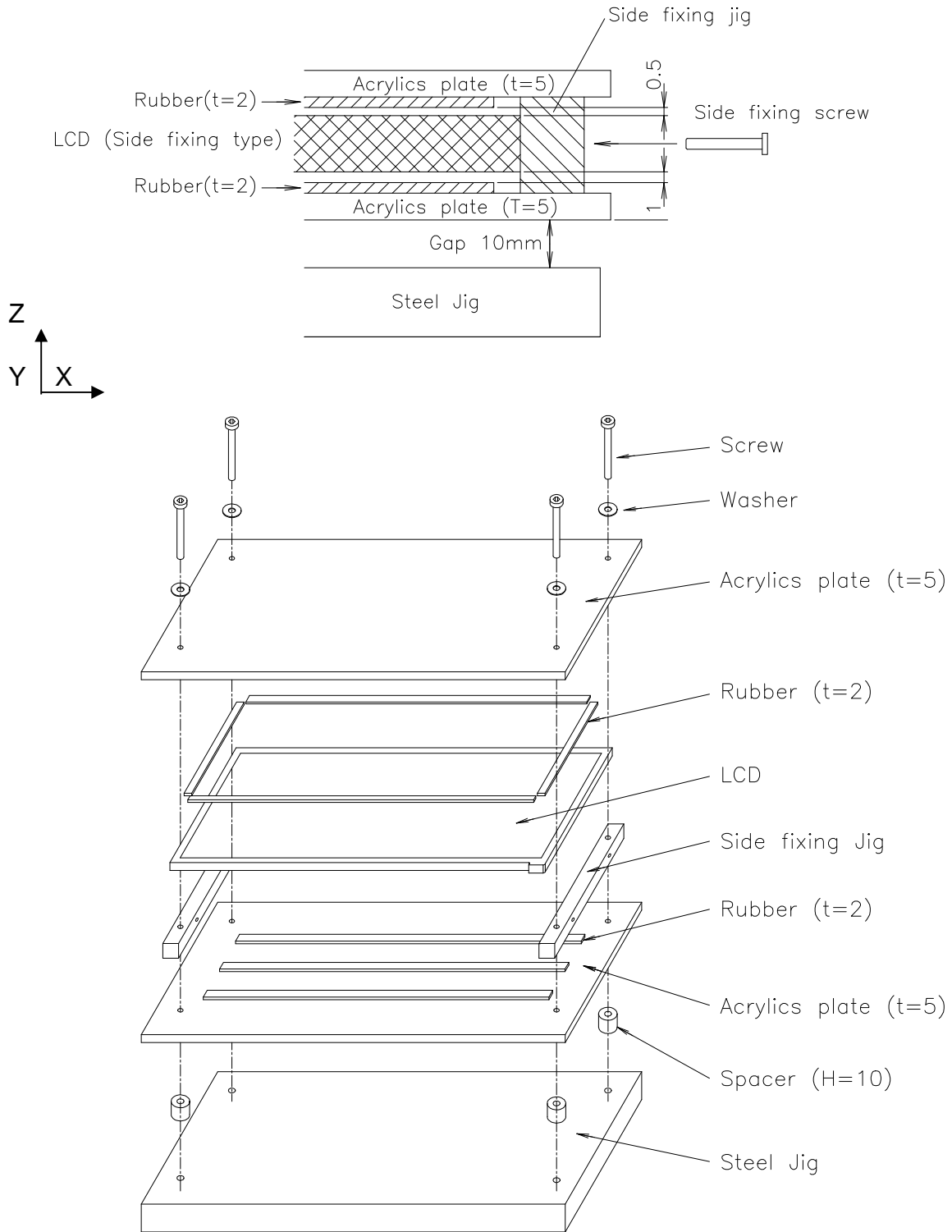

3.4. The Others

(1) Static electricity pressure resistance

Item	Testing conditions	Operation	Non Operation
Contact discharge	150pF, 330 ohm	± 8KV	± 10 kV
Air discharge	150pF, 330 ohm	± 15KV	± 20 KV

(2) Sound noise

There should be no uncomfortable noise.

Being used under whatever surrounds, when power on/off, the panel should not generate uncomfortable noise. And regarding specified values are negotiated if it is needed.

(3) Open / Short

No smoke, no fiery at any open/ short test

(4) MTBF : 50,000 Hr (except for backlight LED)

4. Optical Characteristics

4.1. Test Conditions

- Ambient Temperature : Ta 25±5°C
- Ambient Humidity : Ha 65±20%RH
- Supply Voltage : VDD 3.3V
- Input Signal : According to typical value in "Electrical Characteristics"
- LED Driver Supply Voltage : VLED = 12V
- LED PWM Duty : DPWM = 100%

The measuring method is shown in 4.2. The following items are measured under stable conditions. The optical characteristics should be measured in a dark room (Screen illuminance < 2 lx) or equivalent state with the methods shown in Note (6).

4.2. Optical Specifications

Item	Symbol	Conditions	Min.	Typ.	Max.	Unit	Note	
Contrast Ratio (Center 1 Point)	CR		300	350	-	-	(2), (6)	
Response Time	$t_{ON}+t_{OFF}$			16	25	ms	(3)	
	t_{ON}			5.5	9	ms		
	t_{OFF}			10.5	16	ms		
Average luminance (5 Point Average)	Y_L	$\theta=0^\circ, \phi=0^\circ$	170	200	-	cd/m ²	*V _{LED} =12V D _{PWM} =100% Gray Scale Level = L63 (White)	
Cross Modulation	D _{SHA}	Viewing normal angle	-	-	2.0	%	(5)	
Luminance Uniformity Chromaticity	Red	Rx	0.547	0.577	0.607	-	(1), (6) PR650 Only for Color Coordinate	
		Ry	0.317	0.347	0.377			
	Green	Gx	0.308	0.338	0.368			
		Gy	0.531	0.561	0.591			
	Blue	Bx	0.129	0.159	0.189			
		By	0.097	0.127	0.157			
	White	Wx	0.283	0.313	0.343			
		Wy	0.299	0.329	0.359			
Viewing Angle	Hor.	θ_L	CR>=10	$\phi = 180^\circ$	40	45	-	deg. (Color Coordinate of the R,G,B is based on LGD's equipment, and Color Coordinate of the W is based on LGD's equipment)
		θ_R		$\phi = 0^\circ$	40	45	-	
	Ver.	θ_{up}	$\phi = 90^\circ$	10	15	-		
		θ_{Low}	$\phi = -90^\circ$	30	35	-		
	Hor.	CR>=5	θ_L	$\phi = 180^\circ$	50	55	-	
			θ_R	$\phi = 0^\circ$	50	55	-	
	Ver.	θ_{up}	$\phi = 90^\circ$	10	15	-		
		θ_{Low}	$\phi = -90^\circ$	30	35	-		
13 Points White Variation	δW	$\theta=0^\circ, \phi=0^\circ$	-	-	1.6		(7)	
13 Points CR Variation	δC_R	Viewing	-	-	2.0		(7)	
White Variation	dL	normal angle	-	-	2.0		(8)	

Attach the LED current – Luminance characteristics. The range of LED current is shown in 3.2 (2)

A. Present CR Variation(13Point) Spec is based on PR-880 Equipment and can be changed by the measuring equipment.

Item	Gray level	Conditions	Min.	Typ.	Max.	Unit	Note
Normalized luminance at each gray level	63	$\theta=0^\circ, \phi=0^\circ$ Viewing normal angle	100	100	100	%	(1), (6) (Center 1 Point)
	55		60	74	88		
	47		36.8	52.49	68		
	39		20	34.82	50		
	31		9.5	21.01	33		
	23		3.5	12.21	21.5		
	15		0.95	5.36	11.6		
	7		0.09	1.45	4.9		
	0		0.00	0.12	0.9		

At normal viewing direction, during displaying the L0-L63 gray scale bar, luminance intensity inversion can not be seen.

Note 1) Definition of viewing angle θ and ϕ

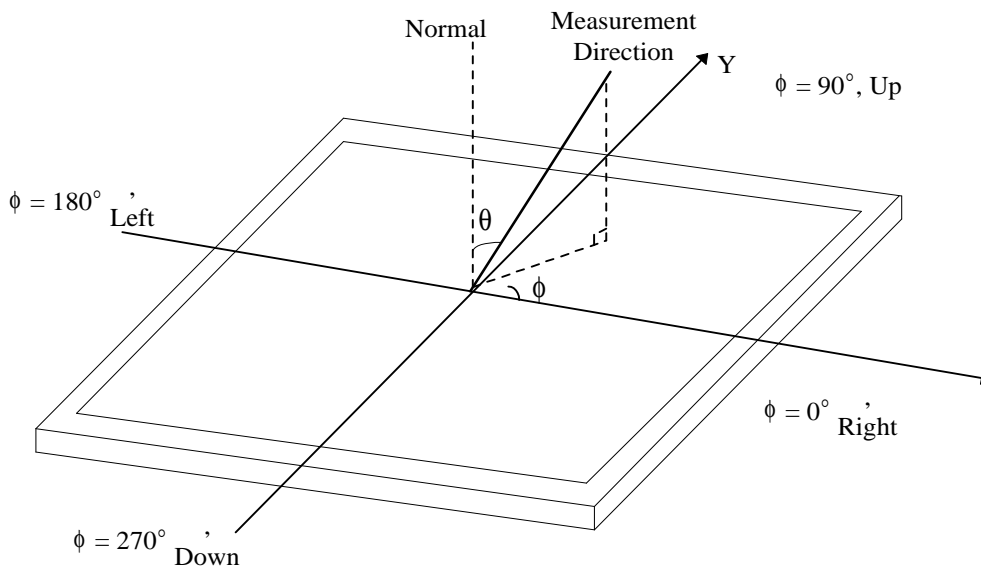

Note 2) LCD fixing condition for z direction.

The contrast ratio can be calculated by the following expression.

$$\text{Contrast Ratio (CR)} = L63 / L0$$

L63 : Luminance on the white raster (gray scale level L63)

L 0 : Luminance on the black raster (gray scale level L0)

Note 3) Definition of response time

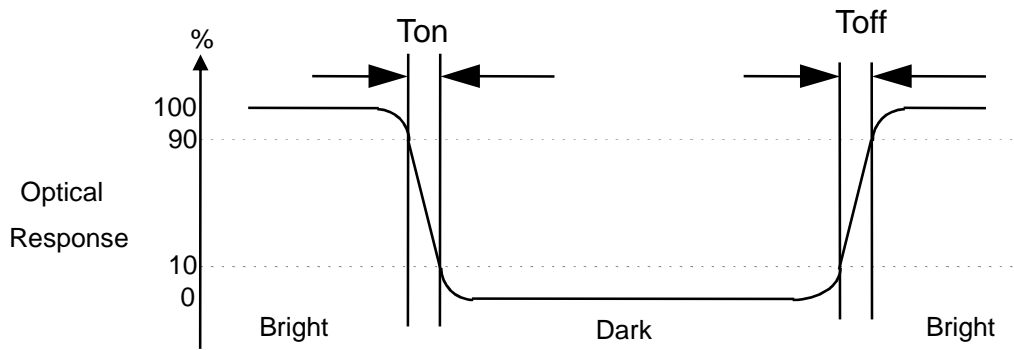

Note 4) Definition of surface luminance of white

Measure the luminance of white at Center point. Surface luminance of white Y_L

Note 5) Definition of Cross Modulation (D_{SHA})

$$D_{SHA} = |Y_B - Y_A| / Y_A \times 100 (\%)$$

Where:

Y_A = Luminance of measured location without darkest gray pattern (cd/m^2)

Y_B = Luminance of measured location with darkest gray pattern (cd/m^2)

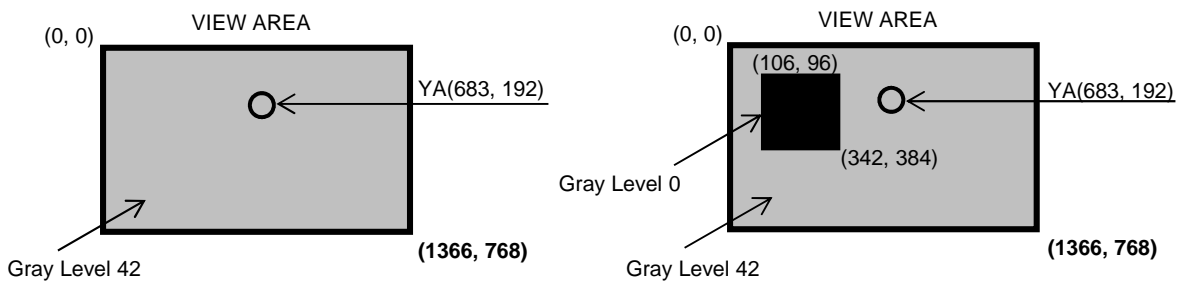

Note 6) Measuring setup

The measurement suppose to be executed after stabilized the panel at given temperature during 30 min. The measurement shall be executed 30 minutes after lighting at rating. The luminance of white should be typical luminance (Typical Condition IL=6.0mA). In order to stable the luminance, LCD s hall not be got winds.

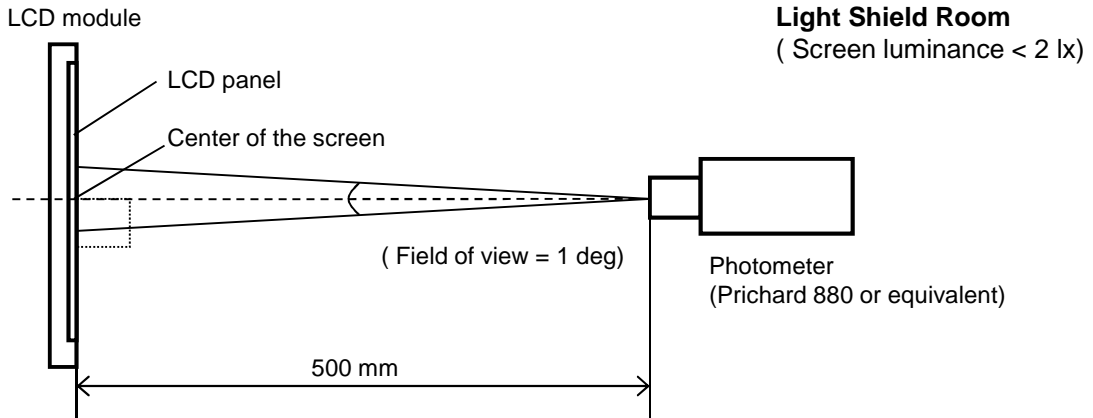

Note 7) Definition of 13 points white variation δW , CR variation δC_R

δW = Maximum luminance of 13 points / Minimum luminance of 13 points

δC_R = Maximum CR 13 points / Minimum CR of 13 points

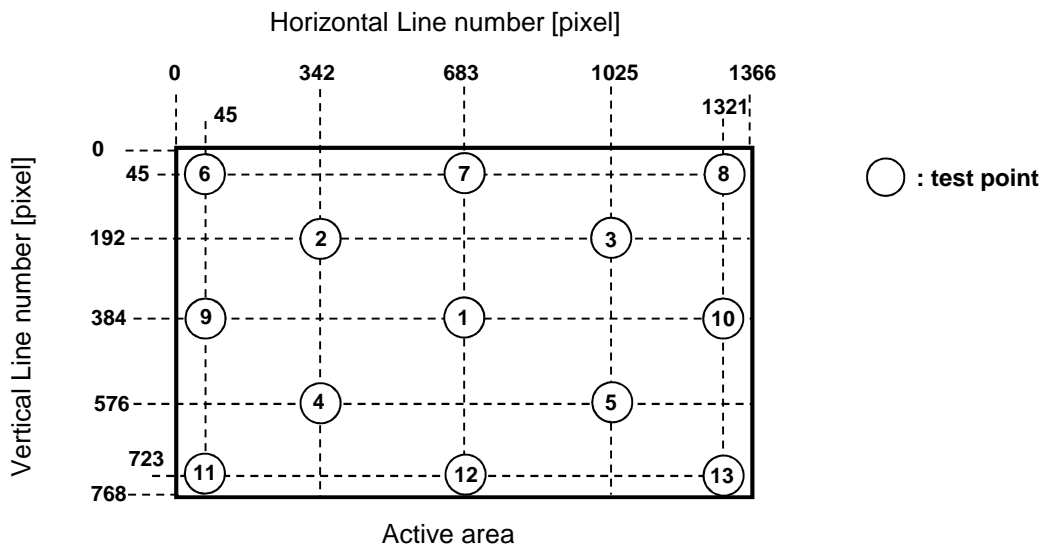

Note 8) Definition of White Variation dL : measure the luminance of white at 13 × 11 points.

$$dL = [| L(x,y) - L(x+l, y+j) | / (L(x,y) \times D(x+l, y+j))] \times 100 \text{ (%/mm)}$$

where $2 \leq x \leq 15, 2 \leq y \leq 11, l = \pm 1, j = \pm 1$

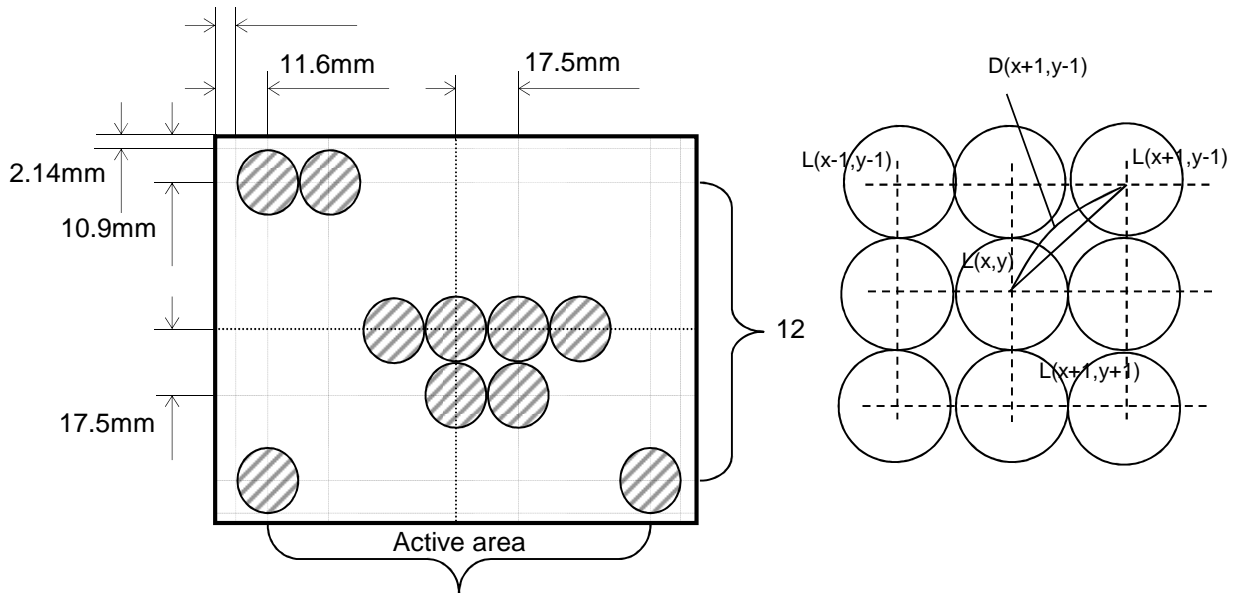

Measuring Spot 16
 (Field of View : 2deg. Measuring Distance : 500 mm)

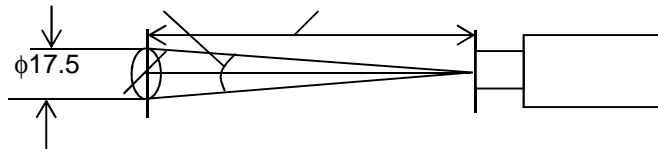

5. Electrical Characteristics

5.1. TFT LCD module

Item	Symbol	Min.	Typ.	Max.	Unit	Note
Power Supply Voltage	V_{DD}	3.0	3.3	3.6	V	
Differential Input Threshold Voltage	High	V_{th}	-	+100	mV	
	Low	V_{tl}	-100	-	mV	
Rush Current	I_{RUSH}	-	-	1.5	A	(5)
Power Supply Current	White(L63)	195	225	255	mA	(3), (4) (a)
	Mosaic	265	315	365		(3), (4) (b)
	Max. Pattern	350	410	470		(3), (4) (c)

Note 1) The module should be always operated within these ranges. The "Typ." shows the recommendable value.

Note 2) Recommended LVDS transmitter : SN75LVDS84 (made by TI)

LVDS receiver included in this module is SW0617.(1 chip)

Note 3) Typical condition as follows. : fV= 60Hz, fDCLK = 69.3 MHz, V_{DD} = 3.3V, DC current.

Note 4) Power dissipation check pattern.

(a) White pattern

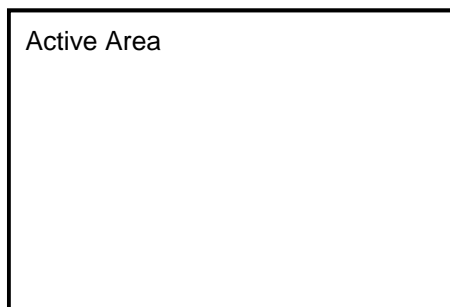

(b) Mosaic pattern

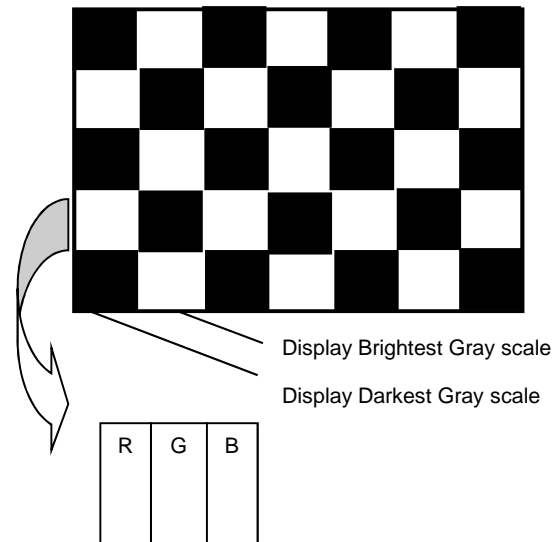

(C) Max. pattern

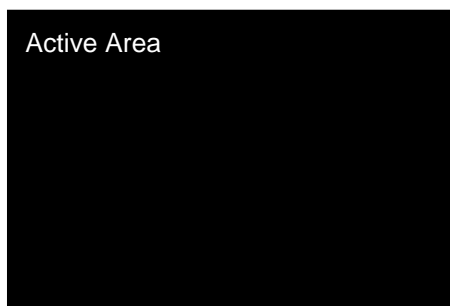

Note 5) Measuring condition of rush current.

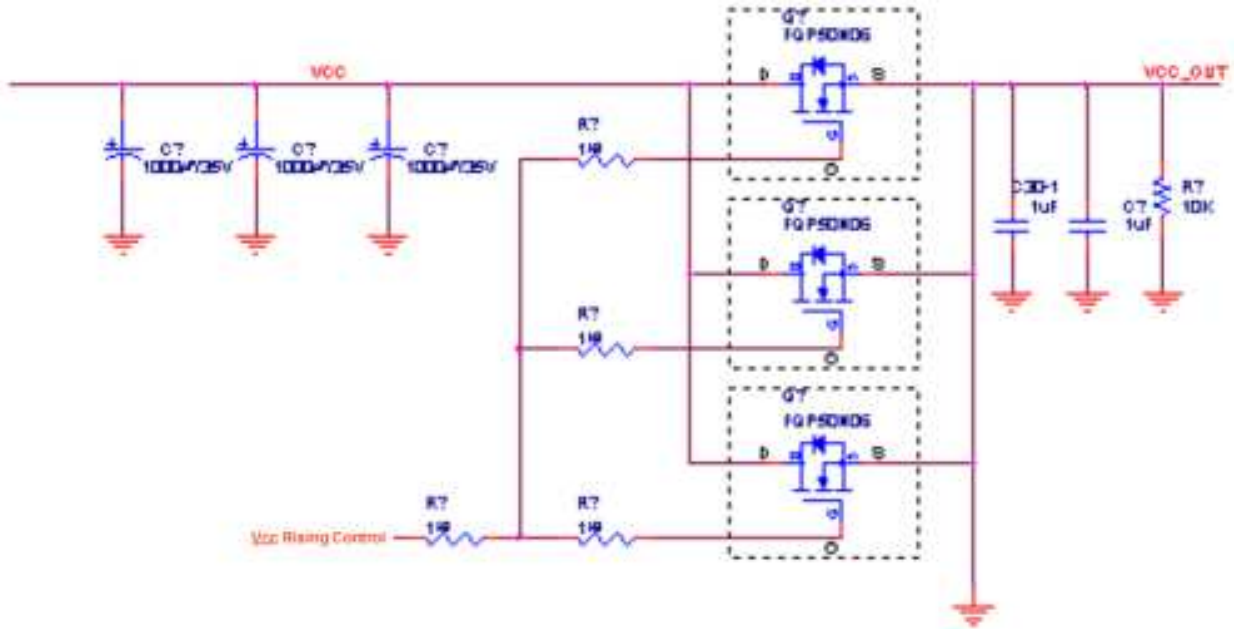

V_{DD} rising time is 500us

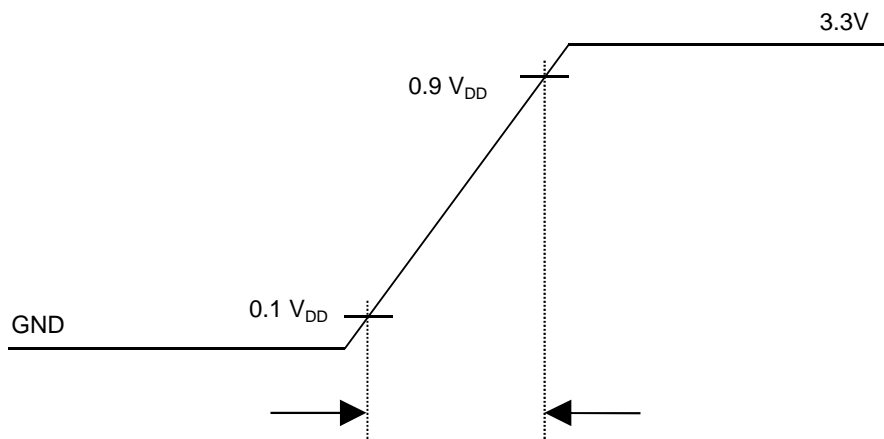

5.2. Backlight Unit

Parameter	Symbol	Values			Unit	Notes
		Min	Typ	Max		
BACKLIGHT : (with LED Driver)						
LED Power Input Voltage	V _{LED}	7.0	12.0	21.0	V	1
LED Power Input Current	I _{LED}	-	200	220	mA	2
LED Power Consumption	P _{LED}	-	2.4	2.6	W	3
LED Power Inrush Current	I _{LED_P}	-	-	1000	mA	4
PWM Duty Ratio		5	-	100	%	5
PWM Jitter	-	0	-	0.2	%	6
PWM Impedance	Z _{PWM}	20	40	60	kΩ	
PWM Frequency	F _{PWM}	200	1000	2000	Hz	7
PWM High Level Voltage	V _{PWM_H}	3.0	-	5.3	V	
PWM Low Level Voltage	V _{PWM_L}	0	-	0.3	V	
LED_EN Impedance	Z _{PWM}	20	40	60	kΩ	
LED_EN High Voltage	V _{LED_EN_H}	3.0	-	5.3	V	
LED_EN Low Voltage	V _{LED_EN_L}	0	-	0.3	V	
Life Time		12,000	-	-	Hrs	8

1. This impedance value is needed for proper display and measured from LVDS Tx to the mating connector.
2. The measuring position is the connector of LCM and the test conditions are under 25°C.
3. The current and power consumption with LED Driver are under the V_{led} = 12.0V , 25°C, Dimming of Max luminance and White pattern with the normal frame frequency operated(60Hz).
4. The below figures are the measuring V_{led} condition and the V_{led} control block LGD used.
V_{LED} control block is same with V_{cc} control block.

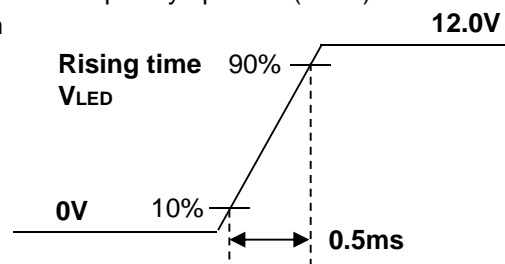

5. The operation of LED Driver below minimum dimming ratio may cause flickering or reliability issue.
6. If Jitter of PWM is bigger than maximum, it may induce flickering.
7. This Spec. is not effective at 100% dimming ratio as an exception because it has DC level equivalent to 0Hz. In spite of acceptable range as defined, the PWM Frequency should be fixed and stable for more consistent brightness control at any specific level desired.
8. The life time is determined as the time at which the typical brightness of LCD is 50% compare to that of initial value at the typical LED current. These LED backlight has 4 strings on it and the typical current of LED's string is base on 18mA.

5.3. Regulation

The set (which LCD module is assembled into) should conform to the regulations below.

(1) EMC Regulations.

- a) ANSI C63.4
- b) CISPR 22
- c) CISPR 13

(2) Safety Regulations (Only LCD)

- a) UL 60950-1, Second Edition, Underwriters Laboratories Inc.
- b) CAN/CSA C22.2 No.60950-1-07, Second Edition, Canadian Standards Association.
- c) EN 60950-1:2006 + A11:2009, European Committee for Electrotechnical Standardization (CENELEC).
- d) IEC 60950-1:2005, Second Edition, The International Electrotechnical Commission (IEC).

(3) Environment

- a) RoHS, Directive 2002/95/EC of the European Parliament and of the council of 27 January 2003

(4) Material list concerning

Item	Silk	Product	Rating	Maker	
TCON	TCON OUTPUT (Data Output)	R12, R13, R14, R15	Resistor	100Ω	ROHM, Samsung Elec., Walsin
	Power V _{cc} (2.5V)	UC1	TCON	2.5V	Siliconworks
DC/DC	Control IC for Power supply	US1	SW5024	SW5024, Siliconworks, NBPC, Boost+LDO+L/S+OP-Amp+PVcom+D/C+GPM, TQFN (6x6), R/TP, 48 pin	Siliconworks
	Switching Diode	D11	DAN217U	DC/DC Switching frequency (400Khz ~ 1200Khz)	DIODES
	Schottky Barrier Diode	D3, D10	BAT750-7-F	0.75A	DIODES
	Inductor	L2, L3	NRS4012T100M	10 uH ± 20% (Inductance) 0.310Ω ± 20% (DC Resistance) 0.95A Max (Rated DC Current)	KTY
LED Driver	Control IC for LED	US3	ADD5201	ADD5201, ANALOG DEVICE, 21V, 8CH, -, LFCSP, R/TP, 28, NBPC	Analog Device
	Inductor	L4	NRS4012T100M	10 uH ± 20% (Inductance) 0.310Ω ± 20% (DC Resistance) 0.95A Max (Rated DC Current)	KTY

6. Block Diagram

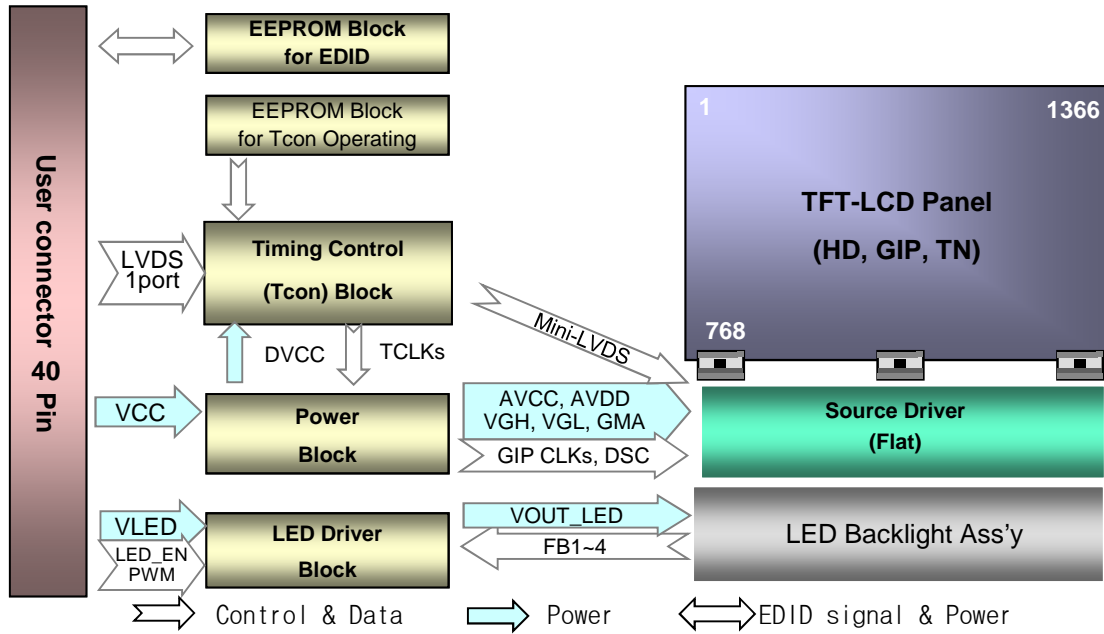

7. Input Terminal Pin Assignment

7.1. TFT LCD module

This LCD employs two interface connections, a 40 pin connector is used for the module electronics interface and the other connector is used for the integral backlight system.

Table 3. MODULE CONNECTOR PIN CONFIGURATION (CN1)

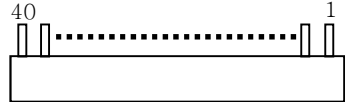
Pin	Symbol	Description	Notes
1	NC	No Connection	1. Interface chips 1.1 LCD : SW, SW0617 (LCD Controller) including LVDS Receiver 1.2 System : THC63LVDF823A or equivalent * Pin to Pin compatible with LVDS 2. Connector 2.1 LCD : UJU IS050-L40B-C10 2.2 Mating : 20453-#40E-## series or equivalent 2.3 Connector pin arrangement  [LCD Module Rear View]
2	VCC	LCD Logic and driver power (3.3V Typ.)	
3	VCC	LCD Logic and driver power (3.3V Typ.)	
4	V _{EE} DD	DDC Power (3.3V)	
5	NC	No Connection	
6	Clk _{EE} DD	DDC Clock	
7	DATA _{EE} DD	DDC Data	
8	ORX0-	Negative LVDS differential data input	
9	ORX0+	Positive LVDS differential data input	
10	GND	LCM Ground	
11	ORX1-	Negative LVDS differential data input	
12	ORX1+	Positive LVDS differential data input	
13	GND	LCM Ground	
14	ORX2-	Negative LVDS differential data input	
15	ORX2+	Positive LVDS differential data input	
16	GND	LCM Ground	
17	ORXC-	Negative LVDS differential clock input	
18	ORXC+	Positive LVDS differential clock input	
19	GND	LCM Ground	
20	NC	No Connection	
21	NC	No Connection	
19	GND	LCM Ground	
23	NC	No Connection	
24	NC	No Connection	
19	GND	LCM Ground	
26	NC	No Connection	
27	NC	No Connection	
19	GND	LCM Ground	
29	NC	No Connection	
30	NC	No Connection	
31	GND	LCM Ground (LED Backlight Ground)	
32	GND	LCM Ground (LED Backlight Ground)	
33	GND	LCM Ground (LED Backlight Ground)	
34	NC	No Connection	
35	PWM	System PWM Signal input for dimming	
36	LED_EN	LED Backlight On/Off	
37	NC	No Connection	
38	VLED	LED Backlight Power (7V-21V)	
39	VLED	LED Backlight Power (7V-21V)	
40	VLED	LED Backlight Power (7V-21V)	

7.3. LVDS Transmitter

LVDS Transmitter : SN75LVDS84 (made by TI) or compatible.

Pin #	Pin Name	Require Signals	Pin #	Pin Name	Require Signals
1	D4	R4	48	D3	R3
2	Vcc	Vcc	47	D2	R2
3	D5	R5	46	GND	GND
4	D6	G0	45	D1	R1
5	DND	GND	44	D0	R0
6	D7	G1	43	NC	NC
7	D8	G2	42	LVDS GND	LVDS GND
8	Vcc	Vcc	41	Y0M	A0M
9	D9	G3	40	Y0P	A0P
10	D10	G4	39	Y1M	A1M
11	GND	GND	38	Y1P	A1P
12	D11	G5	37	LVDS Vcc	LVDS Vcc
13	D12	B0	36	LVDS GND	LVDS GND
14	NC	NC	35	Y2M	A2M
15	D13	B1	34	Y2P	A2P
16	D14	B2	33	CLKOUTM	CLKM
17	GND	GND	32	CLKOUTP	CLKP
18	D15	B3	31	LVDS GND	LVDS GND
19	D16	B4	30	PLL GND	PLL GND
20	D17	B5	29	PLL Vcc	PLL Vcc
21	Vcc	Vcc	28	PLL GND	PLL GND
22	D18	HSYNC	27	SHDN	SHDN
23	D19	VSYNC	26	CLKIN	Dclk
24	GND	GND	25	D20	DE(Data Enable)

7.4. Timing Diagrams of LVDS Transmission

Switching Characteristic

VCC = 3.0 ~ 3.6V, Ta = -10 ~ +70°C

Transmitter

Symbol	Parameter	Min.	Typ.	Max.	Unit
tTCIT	CLK IN Transition Time	-	-	5	ns
tTCP	CLK IN Period	14.7	T	32.4	ns
tTCH	CLK IN High Time	0.4T	0.5T	0.6T	ns
tTCL	CLK IN Low Time	0.4T	0.5T	0.6T	ns
tTCD	CLK IN to TCLK +/- Delay	-	14.2	-	ns
tTS	TTL Data Setup to CLK IN	3.0	-	-	ns
tTH	TTL Data Hold from CLK IN	1.5	-	-	ns
tLVT	LVDS Transition Time	0.26	0.7	1.5	ns
tTOP1	Output Data Position 0 (T= 15.38ns)	-0.2	0	0.2	ns
tTOP0	Output Data Position 1 (T= 15.38ns)	T/7 - 0.2	T/7	T/7 + 0.2	ns
tTOP2	Output Data Position 2 (T= 15.38ns)	2T/7 - 0.2	2T/7	2T/7 + 0.2	ns
tTOP3	Output Data Position 3 (T= 15.38ns)	3T/7 - 0.2	3T/7	3T/7 + 0.2	ns
tTOP4	Output Data Position 4 (T= 15.38ns)	4T/7 - 0.2	4T/7	4T/7 + 0.2	ns
tTOP5	Output Data Position 5 (T= 15.38ns)	5T/7 - 0.2	5T/7	5T/7 + 0.2	ns
tTOP6	Output Data Position 6 (T= 15.38ns)	6T/7 - 0.2	6T/7	6T/7 + 0.2	ns
tPLL	Phase Lock Loop Set	-	-	10	ns

AC Timing Diagrams
Transmitter Device

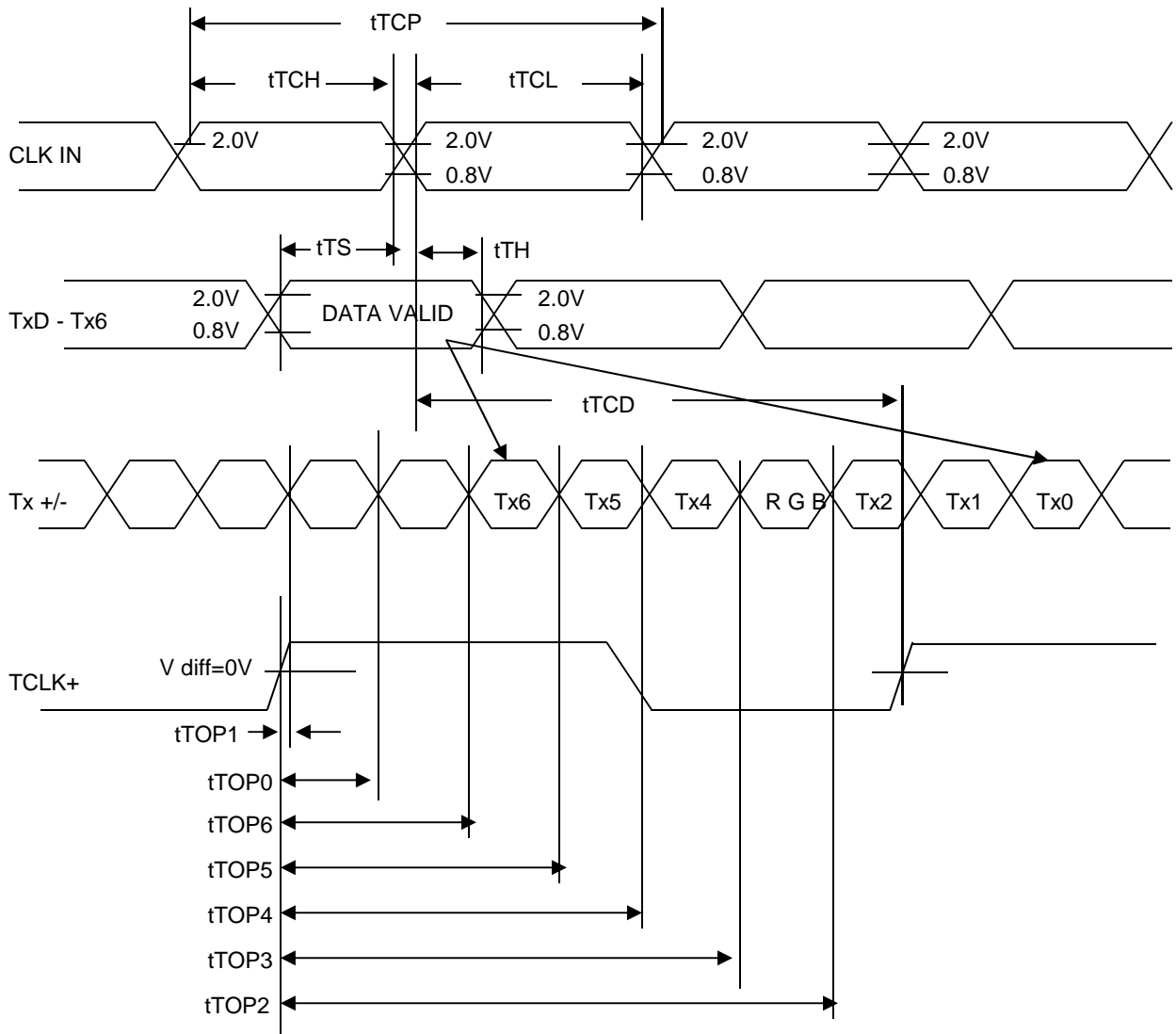

7.5. Input Signal, Basic Display Colors and Gray Scale of each Color

Color		Input Color Data																	
		RED					GREEN					BLUE							
		MSB		RED			LSB		MSB		GREEN			LSB		MSB		BLUE	
		R5	R4	R3	R2	R1	R0	G5	G4	G3	G2	G1	G0	B5	B4	B3	B2	B1	B0
Basic Color	Black	0	0	0	0	0	0	0	0	0	0	0	0	0	0	0	0	0	0
	Red	1	1	1	1	1	1	0	0	0	0	0	0	0	0	0	0	0	0
	Green	0	0	0	0	0	0	1	1	1	1	1	1	0	0	0	0	0	0
	Blue	0	0	0	0	0	0	0	0	0	0	0	0	1	1	1	1	1	1
	Cyan	0	0	0	0	0	0	1	1	1	1	1	1	1	1	1	1	1	1
	Magenta	1	1	1	1	1	1	0	0	0	0	0	0	1	1	1	1	1	1
	Yellow	1	1	1	1	1	1	1	1	1	1	1	1	0	0	0	0	0	0
	White	1	1	1	1	1	1	1	1	1	1	1	1	1	1	1	1	1	1
RED	RED (00)	0	0	0	0	0	0	0	0	0	0	0	0	0	0	0	0	0	0
	RED (01)	0	0	0	0	0	1	0	0	0	0	0	0	0	0	0	0	0	0
							
	RED (62)	1	1	1	1	1	0	0	0	0	0	0	0	0	0	0	0	0	0
	RED (63)	1	1	1	1	1	1	0	0	0	0	0	0	0	0	0	0	0	0
GREEN	GREEN (00)	0	0	0	0	0	0	0	0	0	0	0	0	0	0	0	0	0	0
	GREEN (01)	0	0	0	0	0	0	0	0	0	0	0	1	0	0	0	0	0	0
							
	GREEN (62)	0	0	0	0	0	0	1	1	1	1	1	0	0	0	0	0	0	0
	GREEN (63)	0	0	0	0	0	0	1	1	1	1	1	1	0	0	0	0	0	0
BLUE	BLUE (00)	0	0	0	0	0	0	0	0	0	0	0	0	0	0	0	0	0	0
	BLUE (01)	0	0	0	0	0	0	0	0	0	0	0	0	0	0	0	0	0	1
							
	BLUE (62)	0	0	0	0	0	0	0	0	0	0	0	0	1	1	1	1	1	0
	BLUE (63)	0	0	0	0	0	0	0	0	0	0	0	0	1	1	1	1	1	1

Note 1) 0: Low level voltage, 1: High level voltage

8. Interface Timing

8.1. Timing Parameters

This is the signal timing required at the input of the User connector. All of the interface signal timing should be satisfied with the following specifications and specifications of LVDS Tx/Rx for its proper operation.

ITEM	Symbol	Min.	Typ.	Max.	Unit	Note
DCLK	Frequency	f_{CLK}	67.4	77.4	79.5	MHz @ 60Hz
DCLK	Slow Refresh Rate	f_{CLK}	44.95	51.62	53	MHz @ 40Hz
Hsync	Period	t_{HP}	1450	1642	1674	tCLK
	Width	t_{WH}	28	112	124	
	Width-Active	t_{WHA}	1366	1366	1366	
Vsync	Period	t_{VP}	775	786	792	tHP
	Width	t_{WV}	2	3	5	
	Width-Active	t_{WVA}	768	768	768	
Data Enable	Horizontal back porch	t_{HBP}	28	128	136	tCLK
	Horizontal front porch	t_{HFP}	28	36	48	
	Vertical back porch	t_{VBP}	4	10	12	tHP
	Vertical front porch	t_{VFP}	1	5	7	

Appendix) All reliabilities are specified for timing specification based on refresh rate of 60 Hz.

Even though actual performance in 50Hz and 40Hz for low power is displayed normally, remark and inform to user that display quality in 40 Hz and 50 Hz is out of guarantee range.

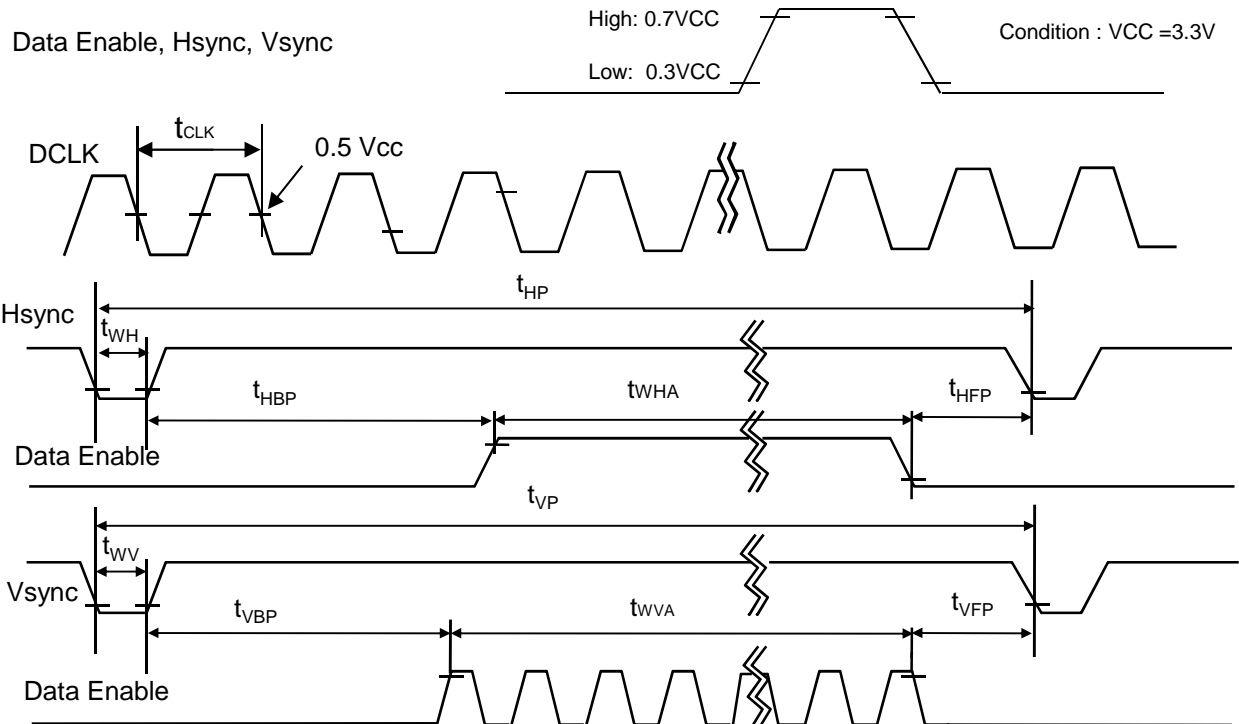

8.3. Power On/Off Sequence

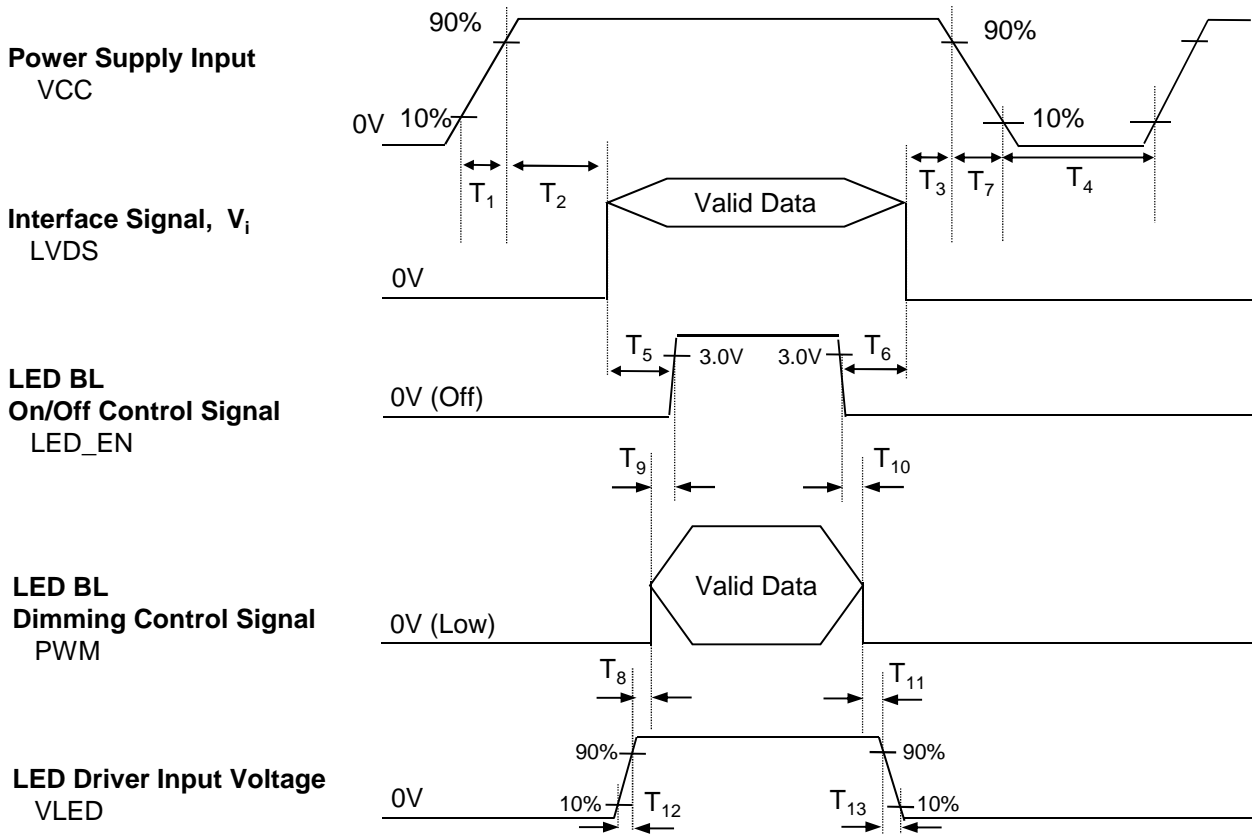

Table 6. POWER SEQUENCE TABLE

Logic Parameter	Value			Units	LED Parameter	Value			Units
	Min.	Typ.	Max.			Min.	Typ.	Max.	
T ₁	0.5	-	10	ms	T ₈	10	-	-	ms
T ₂	0	-	50	ms	T ₉	10	-	-	ms
T ₃	0	-	50	ms	T ₁₀	10	-	-	ms
T ₄	200	-	-	ms	T ₁₁	10	-	-	ms
T ₅	200	-	-	ms	T ₁₂	0.5	-	-	ms
T ₆	0	-	-	ms	T ₁₃	0.1	-	5000	ms
T ₇	0.5	-	10	ms					

Note)

1. Do not insert the mating cable when system turn on.
2. Valid Data have to meet "3-3. LVDS Signal Timing Specifications"
3. LVDS, LED_EN and PWM need to pull-down condition on invalid status.
4. LGD recommend the rising sequence of VLED after the Vcc and valid status of LVDS turn on.

9. Cosmetic Specification

9.1. Sampling

A.Q.L (Acceptable Quality Level): MIL-STD, 105E Level II,

Major: 0.65 , Minor: 1.5

9.2. Conditions of Inspections

- (1) Ambient Temperature : 25±5°C
- (2) Ambient Humidity : 65±20%RH
- (3) Illumination : 200 – 500 Lux (nominal 350 Lux) under the fluorescent Lamp.
- (4) Viewing Distance: Approximately 30cm by the eyes of the inspector from the module
- (5) Viewing angle : The surface of the module and the inspector's line shall be at 90 ± 45 degrees.
- (6) Display pattern: Pure Red, Green, Blue, Black, White, Gray level 0 - 63

9.3. Defect modes

Defect Mode	Description
Dark / Bright spots	Points on the display which appear dark / bright and remain unchanged in size
Dark / Bright lines	Lines on the display which appear dark / bright and remain unchanged in size
Polarizer scratch	When the unit is lit a light , line is seen across a darker background; line does not vary in size
Polarizer dent	When the unit is lit a light, light (white) spots appear against a darker background, and do not vary in size
Bright / dark dot	A sub-pixel (R,G,B dot) stuck off / on
Rubbing line	Diagonal lines that appear gray with the display patterns dark and vary in size
Dim line	When the unit lights, lines in the minor (Vertical) or major (Horizontal) axis appear dim
Cross line	When the unit lights, lines in the both minor and major axis do not appear
Interference	Interference can not be seen with any bright plane display at any viewing angle
Flicker	When displaying sub-pixel checker(gray level and darkest gray), flicker can not be seen
Ripple (Pooling)	Tapping Test, Tapping area : All bezel(Metal cover) side, LCD: Full-screen gray (L32) "Ripple (Pooling)" can not be seen in Active Area

9.4. Mechanical Inspection

- (1) Light leakage: No light leakage between metal chassis (bezel) and glass
- (2) No sharp edge
- (3) The mounting holes: No Changed (Side fixed type)
- (4) PCB Appearance: No pattern peeling snapping / No electrically short
If there are repair portions, the repair portions on PCB is covered by epoxy resin
- (5) Soldering: No cold solder joint, lead move when pulled
- (6) Bezel, Frame, Connectors: No distinct stain, rust or scratch, no pin bending

9.5. Visual Inspection

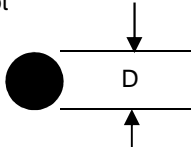
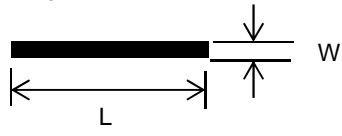
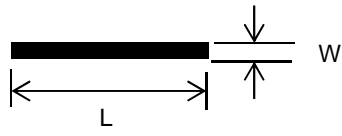
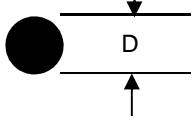
Defect type	Count (mm)	Reject (mm)
Dark / bright spot 	$0.2 < D \leq 0.5$ $N \leq 3$	$D > 0.5$
Dark / Bright lines 	$0.05 < W \leq 0.1$ $0.3 < L \leq 3.0$ $N \leq 3$	$W > 0.1$ $L > 3.0$
Polarizer scratch 	$0.01 < W \leq 0.1$ $0.3 < L \leq 0.5$ $N \leq 3$	$W > 0.1$ $L > 0.5$
Polarizer dent / bubble 	$0.2 \leq D \leq 0.5$ $N \leq 3$	$D > 0.5$
Maximum allowable number of defects	$N \leq 7$	$N > 7$
Rubbing defect	Not allowed	
Dim line	Not allowed	

[D : diameter, W : width, L : length, N : count]

Note 1) Inspection area should be within bezel opening.

Note 2) Dusts which are bigger not less than 0.10mm ($0.1 \leq W$) shall be judged by "Average Diameter".

Note 3) Scratches which are bigger not less than 0.05mm ($0.05 \leq W$) shall be judged by "Average Diameter".

Average Diameter $D = (a+b)/2$ (mm)

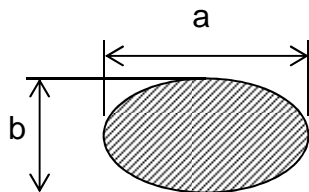

9.6. Electrical Inspection

(1) Dot defect

Defect type		Count	Reject
Bright dots	Random	$N \leq 2$	$N > 3$
	Two adjacent	Not allowed	
	Three or more adjacent	Not allowed	
Dark dots	Random	$N \leq 4$	$N > 5$
	Two adjacent	$N \leq 1$	$N > 2$
	Three or more adjacent	Not allowed	
Maximum allowable number of dot defect		$N \leq 5$	$N > 6$
Maximum distance between defects	Bright - to - bright dot	$L > 15.1\text{mm}$	$L \leq 15\text{mm}$
	Dark - to - dark dot	$L > 10.1\text{mm}$	$L \leq 10\text{mm}$

- 1) Inspection patterns for dot defect are Pure Red, Green, Blue, Black, and White.
- 2) Adjacent two dots will be counted as two dots.
- 3) The distribution of dot defects should be below. Average value of dot defects should be less than 1.

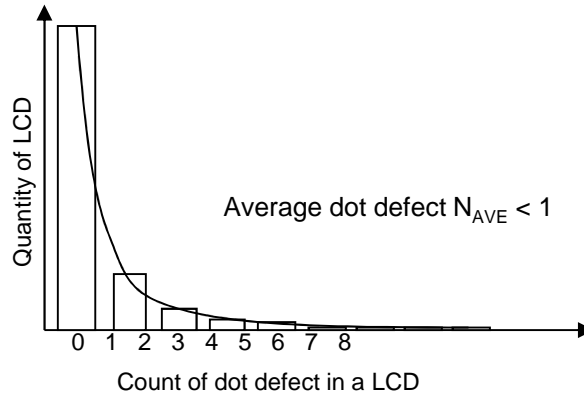

Required distribution of dot defect

4) The definition of 2 adjacent dots.

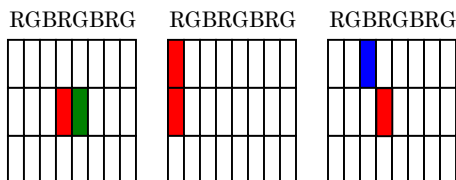

(2) Light leakage

Light leakage can not be seen between metal chassis (bezel) and glass when displaying black plane.

(3) Image sticking

Image sticking pattern shall not be to persist longer than 1second after displaying following pattern 8 hours in the room temperature condition.

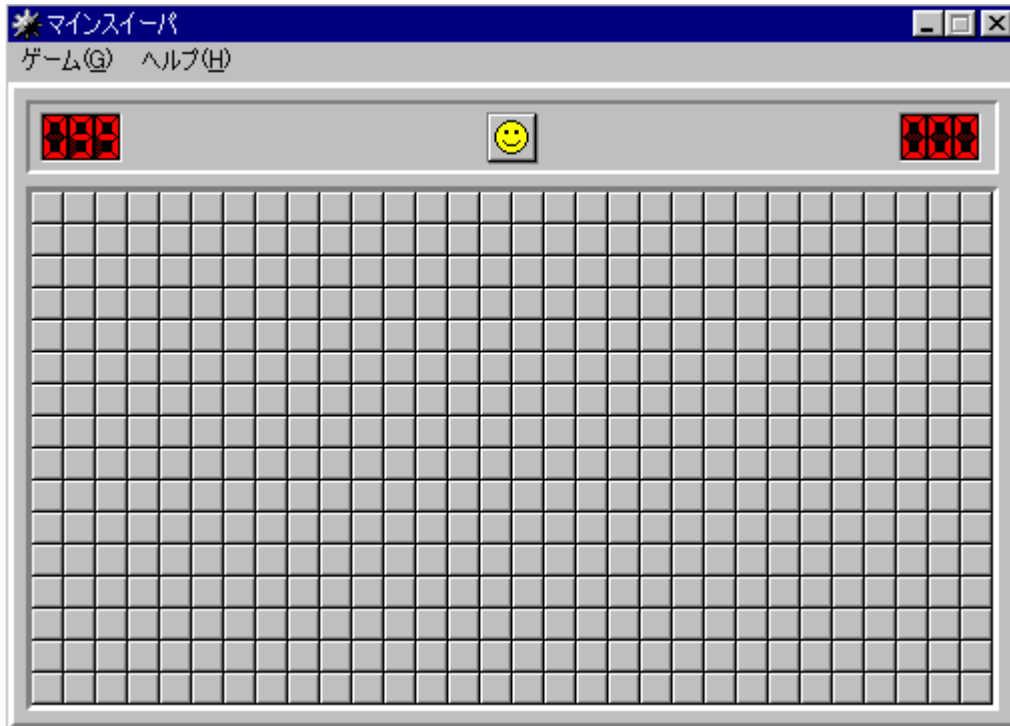

(4) Glue/stain/dirt

Glue, non-removable stain and dirt which are visible in the inspection area are not acceptable.

10. Packing

10.1. Carton

(1) Packing Form

Corrugated cardboard box and EPS Packing

(2) Packing Method

Packing Material : EPS (Expanded Polystyrene)

Packing Weight: : 1.3Kg

(1Box/30Module)

Packing weight, 30 pcs modules included :10.5kg

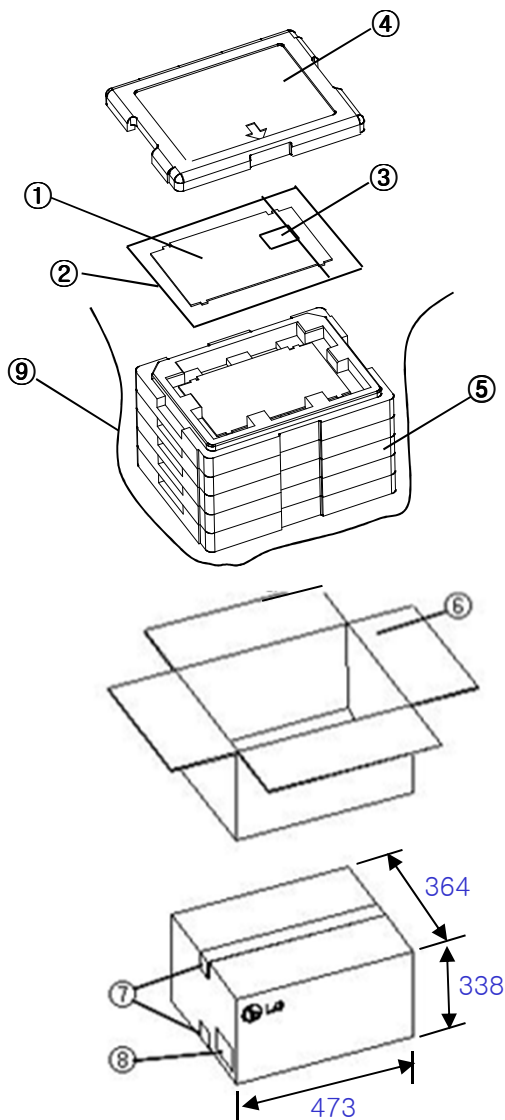

NO.	DESCRIPTION	MATERIAL
1	LCD Module	
2	BAG	LDPE
3	TAPE	MASKING 20MMX50M
4	PACKING, Tray TOP	EPS
5	PACKING, Tray BOTTOM	EPS
6	BOX	SWR4
7	TAPE	OPP 70MMX300M
8	LABEL	ART 100X70
9	AL Bag	AL

(3) Packing Specification

Item	Conditions
Packing Vibration	Random=1.50Grms, Non-Operating LCM, To driving way / 1hr
Packing Drop Test	Refer to below table

Vibration frequency		Drop Height					
Hz	G ² /Hz(PSD)	Bottom side	Left side	Front side	Right side	Rear side	Top side
3	0.0001	drop test, repeat 3x. Drop height according table.	drop test from 0.30 m	drop test from 0.30 m	drop test from 0.30 m	drop test from 0.30 m	drop test from 0.30 m
10	0.0024						
18	0.0024	drop test from 0.30 m	drop test from 0.30 m	drop test from 0.30 m	drop test from 0.30 m	drop test from 0.30 m	drop test from 0.30 m
27	0.02						
54	0.02	drop test from 0.30 m	drop test from 0.30 m	drop test from 0.30 m	drop test from 0.30 m	drop test from 0.30 m	drop test from 0.30 m
100	0.0015						
150	0.0015	drop test from 0.30 m	drop test from 0.30 m	drop test from 0.30 m	drop test from 0.30 m	drop test from 0.30 m	drop test from 0.30 m
200	0.01						
250	0.01	drop test from 0.30 m	drop test from 0.30 m	drop test from 0.30 m	drop test from 0.30 m	drop test from 0.30 m	drop test from 0.30 m
300	0.01						

Mass [kg]	Height [cm]	Mass [kg]	Height [cm]
1	70	15	43
2	70	16	42
3	67	17	41
4	63	18	40
5	60	19	39
6	57	20	38
7	55	21	38
8	53	22	37
9	51	23	37
10	49	24	36
11	48	25	36
12	46	26	36
13	45	27	36
14	44	28 - 50	35

(4) Package Label

Package label should be at least shown the following information.

- a) TOSHIBA code name(G33C00068110) which will be numbered by Toshiba
- b) Revision number which be numbered by LCD maker
- c) Quantity
- d) LCD maker
- e) Model number which be numbered by LCD maker
- f) Production Year / Month

(5) Location of Package label : 1 points (Side)

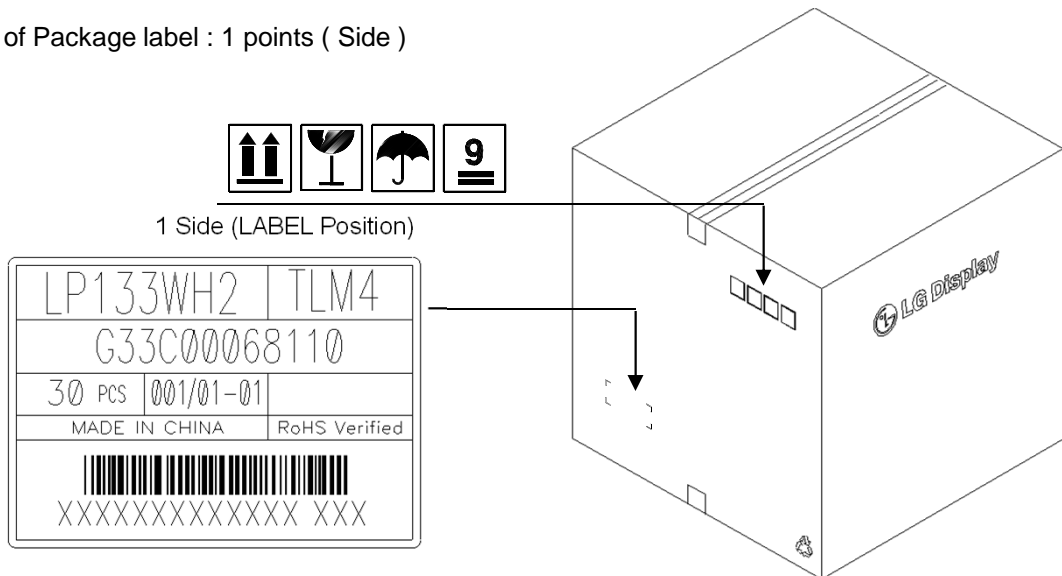

11. Labels and Other parts Exchange

11.1. LCD code Label on LCD

LCD code label should be at least shown the following information.

- (1) TOSHIBA code name (G33C00068110) which will be numbered by Toshiba & Bar code
(Bar code : CODE-39 High-density)
- (2) LGPL Serial number CODE (numbered by LCD maker , less than equal 13 digits)

A	B	C	D	E	F	G	H	I	J	K	L	M
---	---	---	---	---	---	---	---	---	---	---	---	---

A,B,C : SIZE(INCH)
E : MONTH

D : YEAR
F ~ M : SERIAL NO.

Note

1. YEAR

Year	2001	2002	2003	2004	2005	2006	2007	2008	2009	2010
Mark	1	2	3	4	5	6	7	8	9	0

2. MONTH

Month	Jan	Feb	Mar	Apr	May	Jun	Jul	Aug	Sep	Oct	Nov	Dec
Mark	1	2	3	4	5	6	7	8	9	A	B	C

b) Location of Lot Mark

Serial No. is printed on the label. The label is attached to the backside of the LCD module.
This is subject to change without prior notice.

Example >

LABEL : 78mm X 37mm

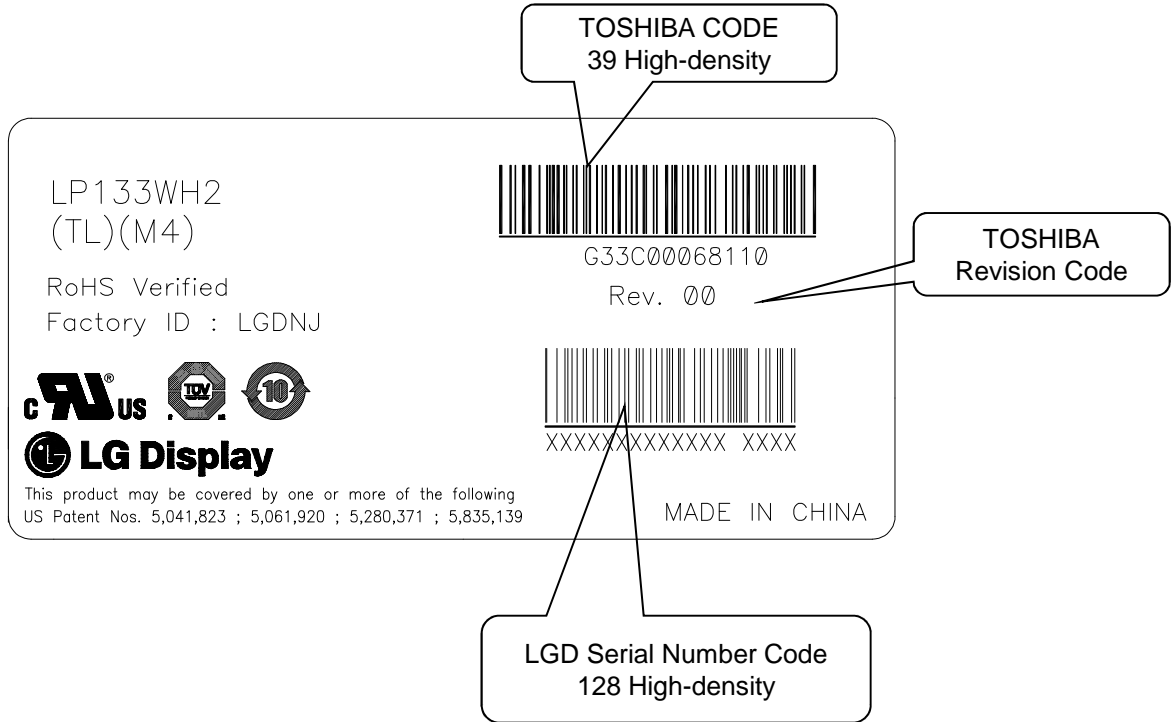

The revision code is inserted in the label by Toshiba request. If the contents of the specification need to be change under mass-production, the code can be revised after Toshiba's approval. Although there is not items in the contents of the specification, Toshiba can requests LGD to change the revision code.

11.2. Caution Texture and Labels on LCD



[Disposal of BL label]

11.3. Label Locations on LCD

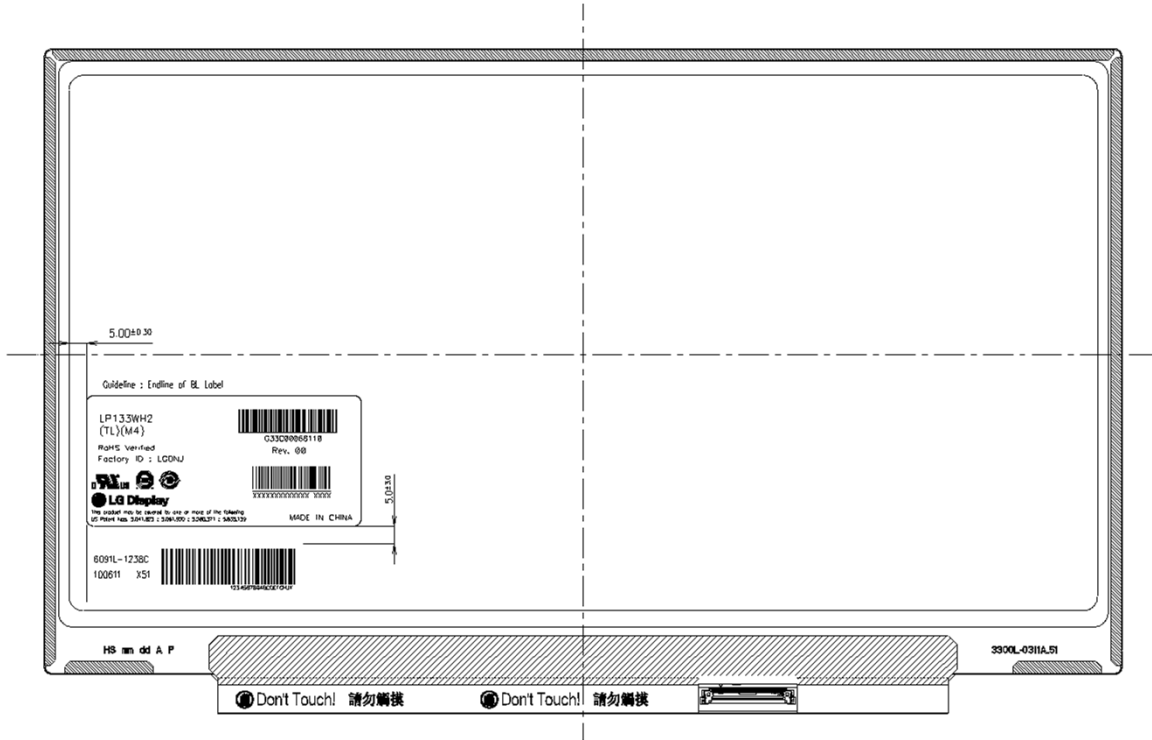

11.4. Others

(1) Backlight repair parts kit : 6091L-1238C

No.	Part	Product Code	Maker	Qt'y	Note
1	Plate Bottom	3300L-0332A		1	
2	Cover Shield(S)	3550S-1024A	Geo rim	1	
3	Cover Shield(T)	3550S-0910A	Geo rim	1	
4	Cover Shield(L,R)	3550S-0921B	Geo rim	2	
5	Tape Adhesive	7250L-0082A	Hwa sung	2	
6	LED	6915L-0070A	SSC	36	

(2) Package specification of Backlight repair parts kit

a) Individual packing

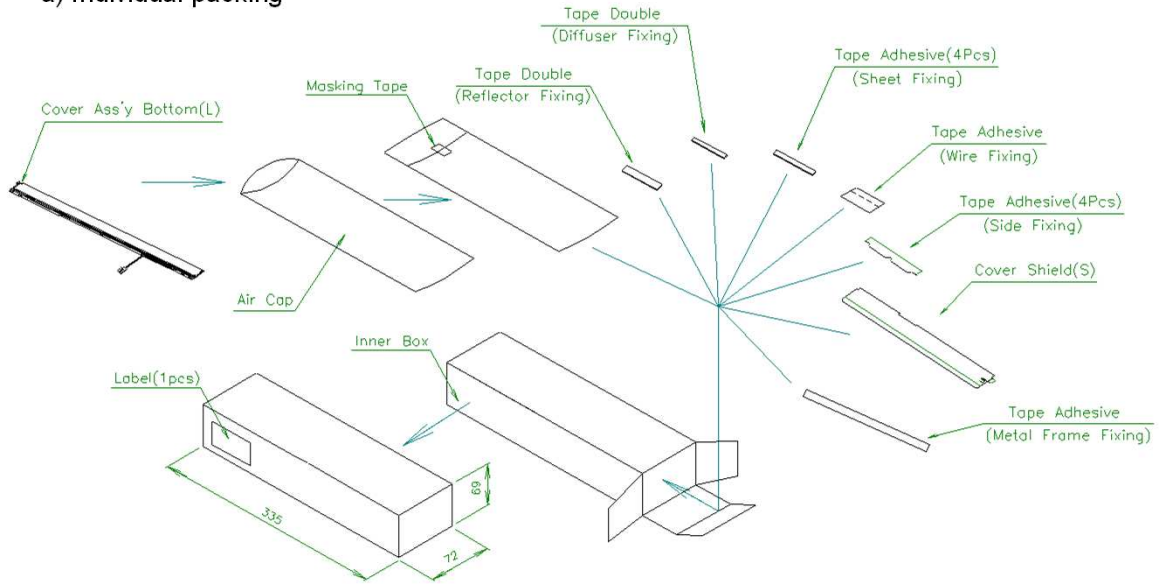

b) Master carton Packing method

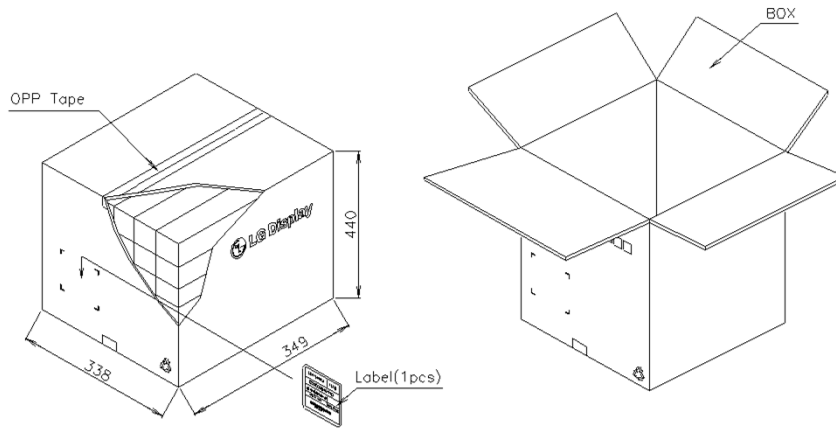

[6(V) x 5(H) = 30 Boxes Inner]

c) Label

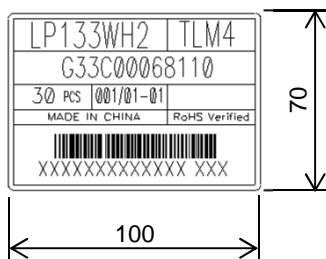

11.5. Instruction of changing the parts

11.5.1. Disassembly of Cover Shield

(1) ① Disassembly of Cover Shield (4 Point)

Caution: Pressure or stress should not be given on Source COF.

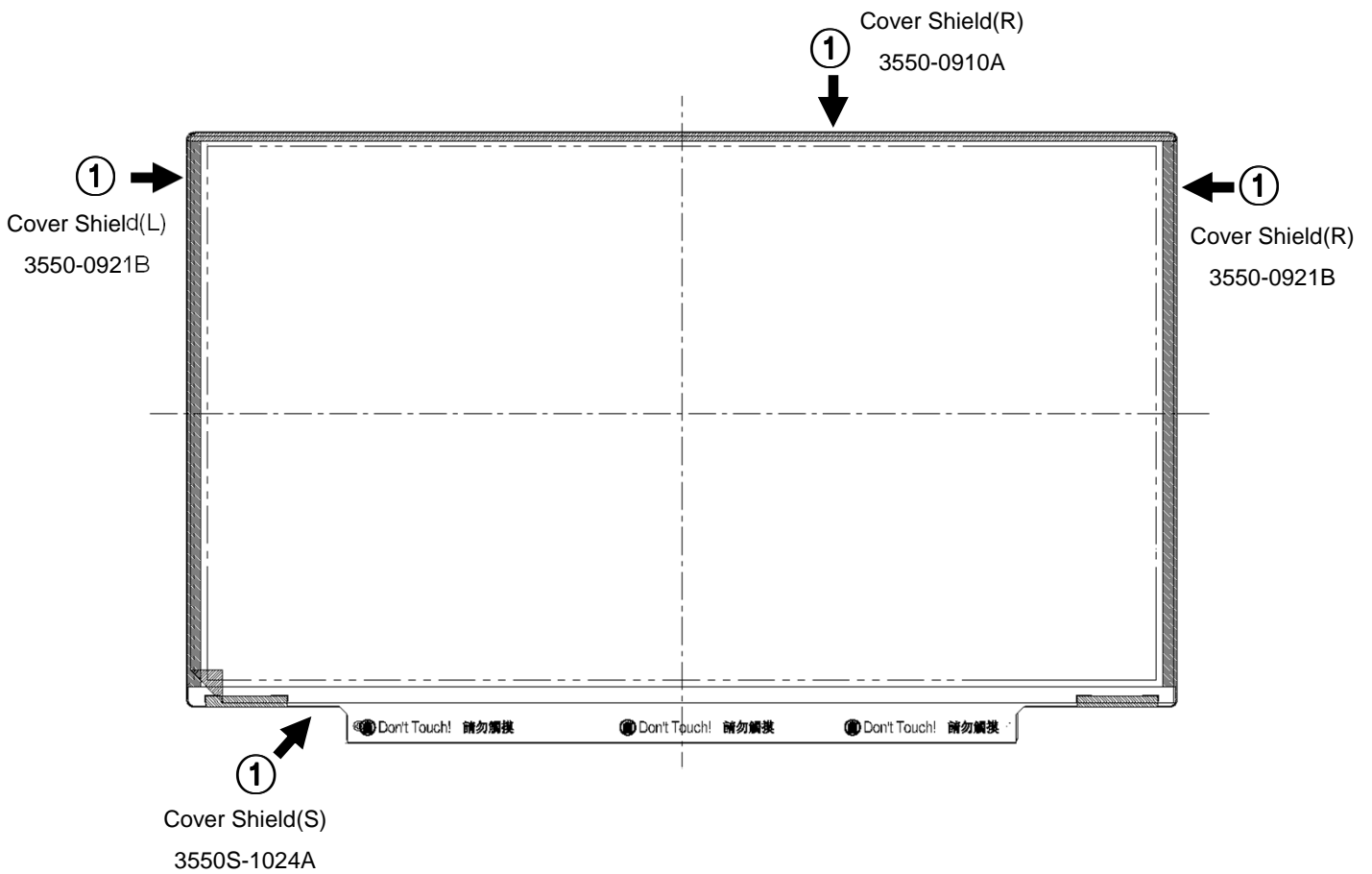

11.5.2. Disassembly of Source PCB

- (1) ① Disassembly of Source PCB.

Caution: Pressure or stress should not be given on PCB and COF.

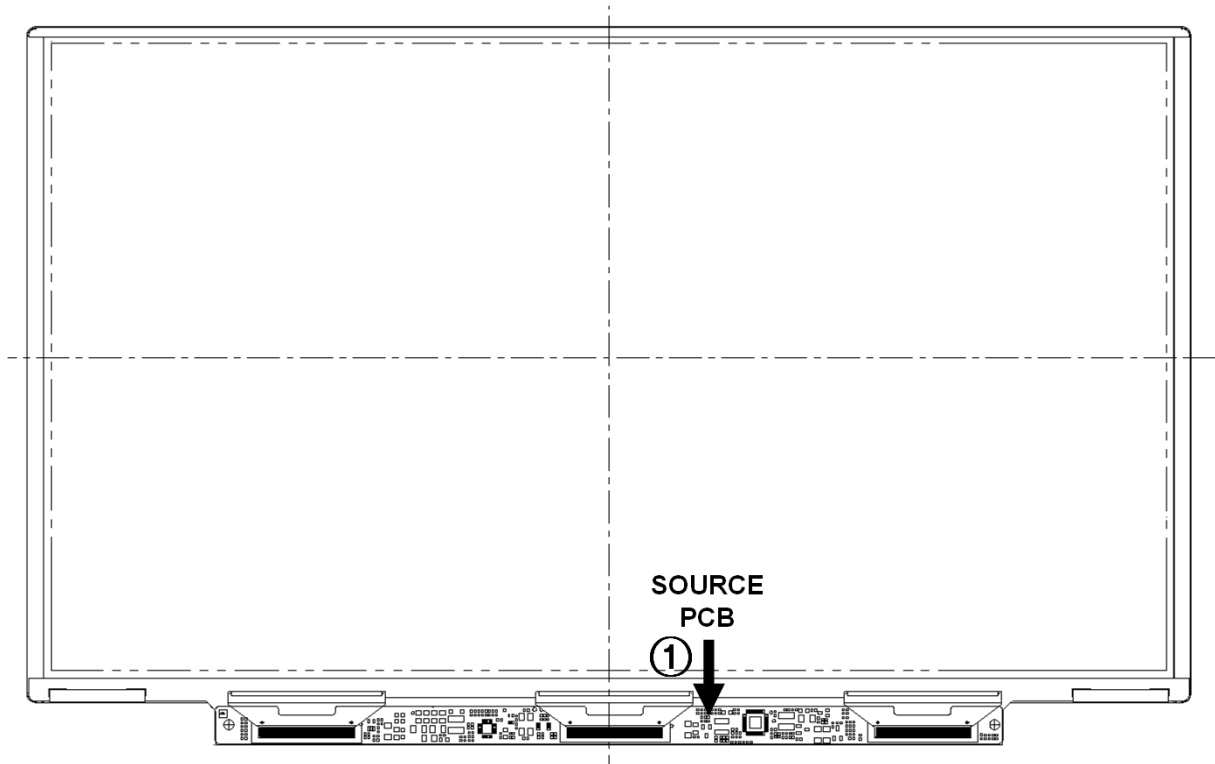

11.5.3. Disassembly of Case top, Board Ass'y, Tape Adhesive, Light guide, Cover Ass'y

- (1) ① Disassembly of Cover Shield (4Point)
- (2) ② Disassembly of Screw for PCB fixing (2Point)
 Caution: Maximum value of torque with Screw should be below 1.5kg.
- (3) ③ Disassembly of Board Ass'y.
 Caution: This process should be made in Clean room with no scratch nor particle on Polarizer and B/L Ass'y.
- (4) ④ Disassembly of Tape Adhesive used for Sheets fixing (4Point).
- (5) ⑤ Disassembly of Sheets, Light guide.
 Caution: No penetration of foreign body is indispensable with no scratch on the surface of each Sheets.
- (5) ⑥ Disassembly of Plate Ass'y

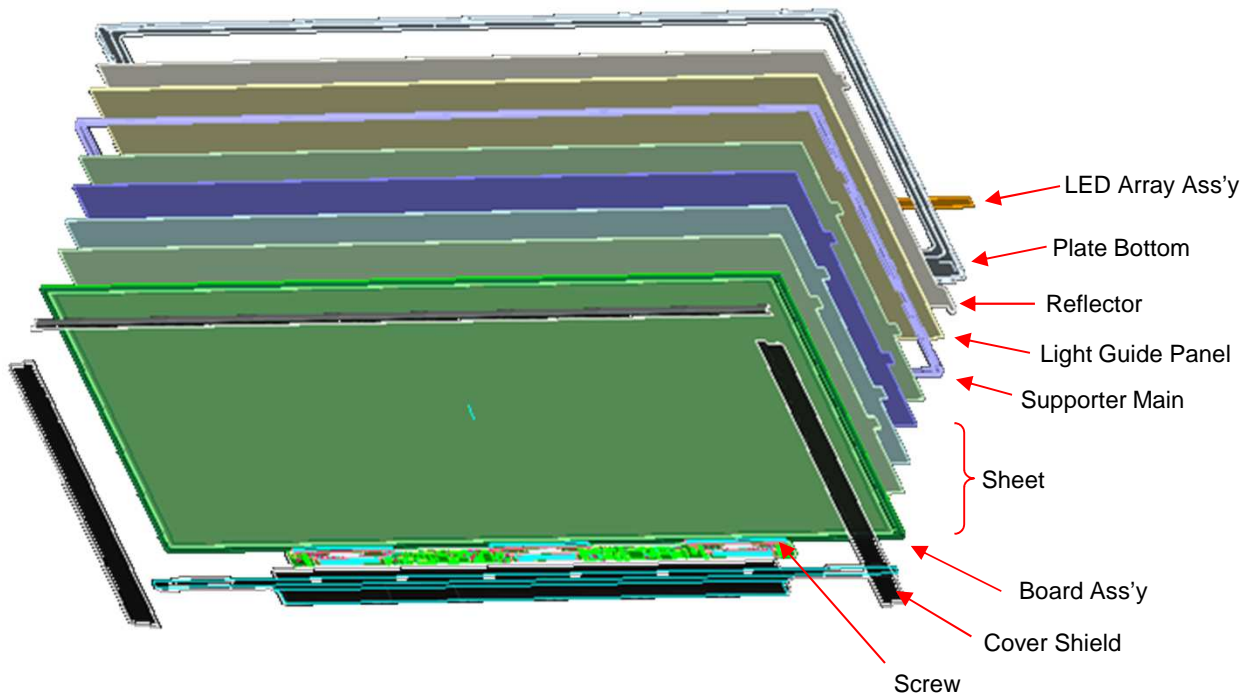

No.	Part	Maker	Maker P/N	Note
1	LGP	Coretronic	5150L-0308A(PMMA)	
2	Diffuser Up	KEIWA	PBS-631S	
3	Prism Up	Suntech	SPX2-5SHK	
4	Prism Down	Suntech	SPX2-5SHK	
5	Diffuser Down	Toray Saehan	TDA10N	
6	Reflector	Dupont	UX150	

11.5.4. Assembly of Cover Ass'y, Sheets, Light guide, Tape Adhesive, Board Ass'y and Case top.

- (1) ① Assembly of Cover Ass'y
- (2) ② Assembly of Light Guide and Sheets.(Reflector Sheet fixing with one Double Tape)
 Caution: No penetration of foreign body is indispensable with no scratch on the surface of each Sheet and Light guide.
- (3) ③ Assembly of Tape adhesive used for Sheets fixing(4Point)
- (4) ④ Assembly of Board Ass'y.
 Caution: Pressure or stress should not be given on PCB and COF.
- (5) ⑤ Assembly of Screw for PCB fixing
 Caution: Maximum value of torque with Screw should be below 1.5kg
- (6) ⑤ Assembly of Cover Shield (4Point)

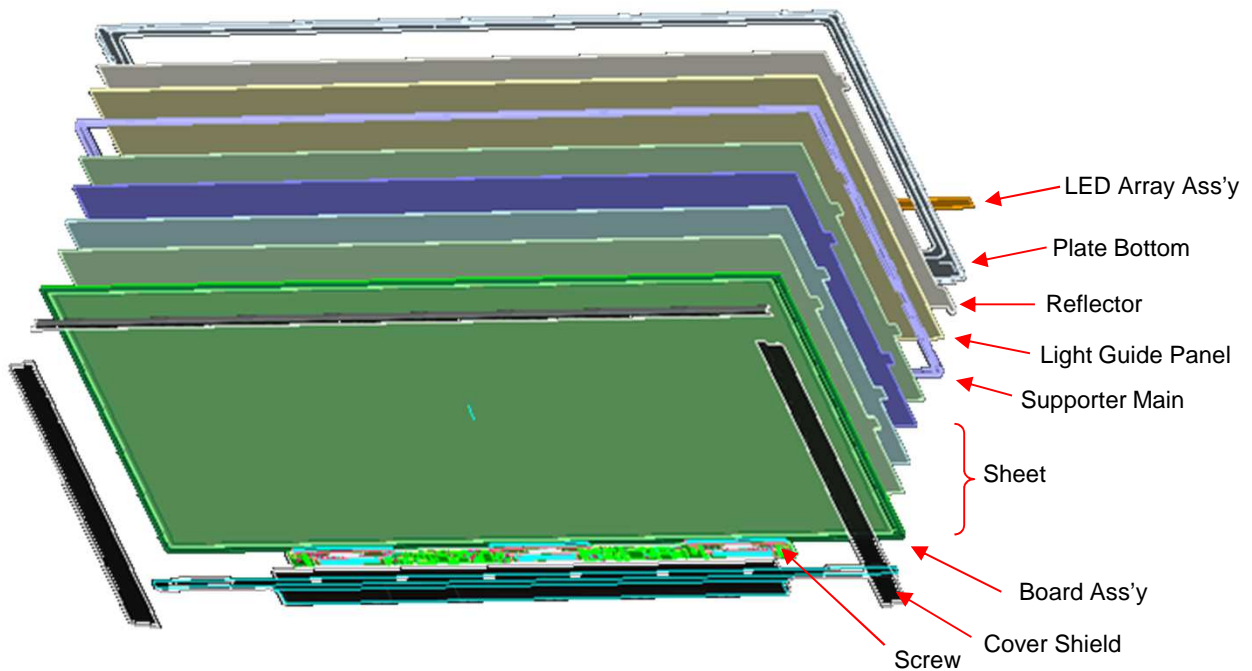

No.	Part	Maker	Maker P/N	Note
1	LGP	Coretronic	5150L-0308A(PMMA)	
2	Diffuser Up	KEIWA	PBS-631S	
3	Prism Up	Suntech	SPX2-5SHK	
4	Prism Down	Suntech	SPX2-5SHK	
5	Diffuser Down	Toray Saehan	TDA10N	
6	Reflector	Dupont	UX150	

12. General Precaution

Please pay attention to the followings when you use this TFT LCD module.

12.1. Mounting Precautions

- (1) You must mount a module using holes arranged in four corners or four sides.
- (2) You should consider the mounting structure so that uneven force (ex. twisted stress) is not applied to the module. And the case on which a module is mounted should have sufficient strength so that external force is not transmitted directly to the module.
- (3) Please attach a transparent protective plate to the surface in order to protect the polarizer. Transparent protective plate should have sufficient strength in order to resist external force.
- (4) You should adopt radiation structure to satisfy the temperature specification.
- (5) Acetic acid type and chlorine type materials for the cover case aren't desirable because the former generates corrosive gas of attacking the polarizer at high temperature and the latter causes circuit break by electro-chemical reaction.
- (6) Do not touch, push or rub the exposed polarizers with glass, tweezers or anything harder than HB pencil lead. And please do not rub with dust clothes with chemical treatment. Do not touch the surface of polarizer for bare hand or greasy cloth. (Some cosmetics are detrimental to the polarizer.)
- (7) When the surface becomes dusty, please wipe gently with absorbent cotton or other soft materials like chamois soaked with petroleum benzene. Normal-hexane is recommended for cleaning the adhesives used to attach front / rear polarizers. Do not use acetone, toluene and alcohol because they cause chemical damage to the polarizer.
- (8) Wipe off saliva or water drops as soon as possible. Their long time contact with polarizer causes deformations and color fading.
- (9) Do not open the case because inside circuits do not have sufficient strength.

12.2. Operating Precautions

- (1) The spike noise causes the mis-operation of circuits. It should be lower than following voltage
: $V = \pm 200\text{mV}$ (Over and under shoot voltage).
- (2) Response time depends on the temperature. (In lower temperature, it becomes longer.)
- (3) Brightness depends on the temperature. (In lower temperature, it becomes lower.) And in lower temperature, response time (required time that brightness is stable after turned on) becomes longer.
- (4) Be careful for condensation at sudden temperature change. Condensation makes damage to polarizer or electrical contacted parts. And after fading condensation, smear or spot will occur.
- (5) When fixed patterns are displayed for a long time, remnant image is likely to occur.
- (6) A module has high frequency circuit. If you need to shield the electromagnetic noise, please co-work. When a Back-light unit is operating, it sounds. If you need to shield the noise, please co-work.

12.3. Electrostatic Discharge Control

Since a module is composed of electronic circuits, it is not strong to electrostatic discharge. Make certain that treatment persons are connected to ground through wrist band etc . And don't touch interface pin directly.

12.4. Precautions for Strong Light Exposure

Strong light exposure causes degradation of polarizer and color filter.

12.5. Storage

When storing modules as spares for a long time, the following precautions are necessary.

- (1) Store them in a dark place. Do not expose the module to sunlight or fluorescent light. Keep the temperature between 5°C and 35°C at normal humidity.
- (2) The polarizer surface should not come in contact with any other object. It is recommended that they be stored in the container in which they were shipped.

12.6. Handling Precautions for Protection Film

- (1) When the protection film is peeled off, static electricity is generated between the film and polarizer. This should be peeled off slowly and carefully by people who are electrically grounded and with well ion-blown equipment or in such a condition, etc.
- (2) The protection film is attached to the polarizer with a small amount of glue. If some stress is applied to rub the protection film against the polarizer during the time you peel off the film, the glue is apt to remain on the polarizer. Please carefully peel off the protection film without rubbing it against the polarizer.
- (3) When the module with protection film attached is stored for a long time, sometimes there remains a very small amount of glue still on the polarizer after the protection film is peeled off.
- (4) You can remove the glue easily. When the glue remains on the polarizer surface or its vestige is recognized, please wipe them off with absorbent cotton waste or other soft material like chamois soaked with normal-hexane.

APPENDIX A. Enhanced Extended Display Identification Data (EEDID™) 1/3

	Byte (Dec)	Byte (Hex)	Field Name and Comments	Value (Hex)	Value (Bin)
Header	0	00	Header	00	00000000
	1	01	Header	FF	11111111
	2	02	Header	FF	11111111
	3	03	Header	FF	11111111
	4	04	Header	FF	11111111
	5	05	Header	FF	11111111
	6	06	Header	FF	11111111
	7	07	Header	00	00000000
Vendor / Product EDID Version	8	08	EISA manufacture code (3 Character ID) LGD	30	00110000
	9	09	EISA manufacture code (Compressed ASC II)	E4	11100100
	10	0A	Panel Supplier Reserved - Product Code 02C8h	C8	11001000
	11	0B	(Hex. LSB first)	02	00000010
	12	0C	L CD Module Serial No - Preferred but Optional ("0" if not used)	00	00000000
	13	0D	L CD Module Serial No - Preferred but Optional ("0" if not used)	00	00000000
	14	0E	L CD Module Serial No - Preferred but Optional ("0" if not used)	00	00000000
	15	0F	L CD Module Serial No - Preferred but Optional ("0" if not used)	00	00000000
	16	10	Week of Manufacture 00 weeks	00	00000000
	17	11	Year of Manufacture 2010 years	14	00010100
	18	12	EDID structure version # = 1	01	00000001
19	13	EDID revision # = 3	03	00000011	
Display Parameters	20	14	Video input Definition = Digital signal	80	10000000
	21	15	Max H image size (Rounded cm) = 29 cm	1D	00011101
	22	16	Max V image size (Rounded cm) = 17 cm	11	00010001
	23	17	Display gamma = (gamma*100)-100 = Example:(2.2*100)-100=120 = 2.2 Gamma	78	01111000
	24	18	Feature Support (no_DPMS,no_Active Off/Very Low Power, RGB color display, Timing BLK 1,no_GTF)	0A	00001010
Panel Color Coordinates	25	19	Red/Green Low Bits (RcGy/GcGy)	FA	11111010
	26	1A	Blue/White Low Bits (BcBy/WcWy)	E5	11100101
	27	1B	Red X Rcx = 0.577	93	10010011
	28	1C	Red Y Ry = 0.347	58	01011000
	29	1D	Green X Gcx = 0.338	56	01010110
	30	1E	Green Y Gcy = 0.561	8F	10001111
	31	1F	Blue X Bcx = 0.159	28	00101000
	32	20	Blue Y Bcy = 0.127	20	00100000
	33	21	White X Wcx = 0.313	50	01010000
	34	22	White Y Wcy = 0.329	54	01010100
Established Timings	35	23	Established timing 1 (00h if not used)	00	00000000
	36	24	Established timing 2 (00h if not used)	00	00000000
	37	25	Manufacturer's timings (00h if not used)	00	00000000
Standard Timing ID	38	26	Standard timing ID1 (01h if not used)	01	00000001
	39	27	Standard timing ID1 (01h if not used)	01	00000001
	40	28	Standard timing ID2 (01h if not used)	01	00000001
	41	29	Standard timing ID2 (01h if not used)	01	00000001
	42	2A	Standard timing ID3 (01h if not used)	01	00000001
	43	2B	Standard timing ID3 (01h if not used)	01	00000001
	44	2C	Standard timing ID4 (01h if not used)	01	00000001
	45	2D	Standard timing ID4 (01h if not used)	01	00000001
	46	2E	Standard timing ID5 (01h if not used)	01	00000001
	47	2F	Standard timing ID5 (01h if not used)	01	00000001
	48	30	Standard timing ID6 (01h if not used)	01	00000001
	49	31	Standard timing ID6 (01h if not used)	01	00000001
	50	32	Standard timing ID7 (01h if not used)	01	00000001
	51	33	Standard timing ID7 (01h if not used)	01	00000001
	52	34	Standard timing ID8 (01h if not used)	01	00000001
	53	35	Standard timing ID8 (01h if not used)	01	00000001

APPENDIX A. Enhanced Extended Display Identification Data (EEDID™) 2/3

	Byte (Dec)	Byte (Hex)	Field Name and Comments	Value (Hex)	Value (Bin)	
<i>Timing Descriptor #1</i>	54	36	Pixel Clock/10,000 (LSB) 69.3 MHz @ 60Hz	12	00010010	
	55	37	Pixel Clock/10,000 (MSB)	1B	00011011	
	56	38	Horizontal Active (lower 8 bits) 1366 Pixels	56	01010110	
	57	39	Horizontal Blanking(Tvp-HA) (lower 8 bits) 104 Pixels	68	01101000	
	58	3A	Horizontal Active / Horizontal Blanking(Tvp-HA)(upper 4:4bits)	50	01010000	
	59	3B	Vertical Active 768 Lines	00	00000000	
	60	3C	Vertical Blanking (Tvp-HA)(DE Blanking typ for DE only panels) 18 Lines	12	00010010	
	61	3D	Vertical Active : Vertical Blanking (Tvp-HA) (upper 4:4bits)	30	00110000	
	62	3E	Horizontal Sync. Offset (Tvp) 32 Pixels	20	00100000	
	63	3F	Horizontal Sync Pulse Width (HSPW) 32 Pixels	20	00100000	
	64	40	Vertical Sync Offset(Tvp) : Sync Width (VSPW) 3 Lines : 5 Lines	35	00110101	
	65	41	Horizontal Vertical Sync Offset/Width (upper 2bits)	00	00000000	
	66	42	Horizontal Image Size (mm) 293 mm	25	00100101	
	67	43	Vertical Image Size (mm) 165 mm	A5	10100101	
	68	44	Horizontal Image Size / Vertical Image Size	10	00010000	
	69	45	Horizontal Border = 0 (Zero for Notebook LCD)	00	00000000	
	70	46	Vertical Border = 0 (Zero for Notebook LCD)	00	00000000	
	71	47	Non-Interlace, Normal display, no stereo, Digital Separate (Vsync_NEG, Hsync_NEG), DE only note : LSB is set to '1' if panel is DE-timing only. H/V can be ignored.	19	00011001	
	<i>Timing Descriptor #2</i>	72	48	Pixel Clock/10,000 (LSB) 46.22 MHz @ 40Hz	0E	00001110
		73	49	Pixel Clock/10,000 (MSB)	12	00010010
		74	4A	Horizontal Active (lower 8 bits) 1366 Pixels	56	01010110
75		4B	Horizontal Blanking(Tvp-HA) (lower 8 bits) 104 Pixels	68	01101000	
76		4C	Horizontal Active / Horizontal Blanking(Tvp-HA)(upper 4:4bits)	50	01010000	
77		4D	Vertical Active 768 Lines	00	00000000	
78		4E	Vertical Blanking (Tvp-HA)(DE Blanking typ for DE only panels) 18 Lines	12	00010010	
79		4F	Vertical Active : Vertical Blanking (Tvp-HA) (upper 4:4bits)	30	00110000	
80		50	Horizontal Sync. Offset (Tvp) 32 Pixels	20	00100000	
81		51	Horizontal Sync Pulse Width (HSPW) 32 Pixels	20	00100000	
82		52	Vertical Sync Offset(Tvp) : Sync Width (VSPW) 3 Lines : 5 Lines	35	00110101	
83		53	Horizontal Vertical Sync Offset/Width (upper 2bits)	00	00000000	
84		54	Horizontal Image Size (mm) 293 mm	25	00100101	
85		55	Vertical Image Size (mm) 165 mm	A5	10100101	
86		56	Horizontal Image Size / Vertical Image Size	10	00010000	
87		57	Horizontal Border = 0 (Zero for Notebook LCD)	00	00000000	
88		58	Vertical Border = 0 (Zero for Notebook LCD)	00	00000000	
89		59	Non-Interlace, Normal display, no stereo, Digital Separate (Vsync_NEG, Hsync_NEG), DE only note : LSB is set to '1' if panel is DE-timing only. H/V can be ignored.	19	00011001	
<i>Timing Descriptor #3</i>		90	5A	Flag	00	00000000
	91	5B	Flag	00	00000000	
	92	5C	Flag	00	00000000	
	93	5D	Data Type Tag (ASCII String)	FE	11111110	
	94	5E	Flag	00	00000000	
	95	5F	ASCII String L	4C	01001100	
	96	60	ASCII String G	47	01000111	
	97	61	ASCII String	20	00100000	
	98	62	ASCII String D	44	01000100	
	99	63	ASCII String i	69	01101001	
	100	64	ASCII String s	73	01110011	
	101	65	ASCII String p	70	01110000	
	102	66	ASCII String l	6C	01101100	
	103	67	ASCII String a	61	01100001	
	104	68	ASCII String y	79	01111001	
	105	69	Manufacturer P/N(N=13 char-> 0Ah, then terminate with ASC II code 0Ah,set remaining char = 20h)	0A	00001010	
	106	6A	Manufacturer P/N(N=13 char-> 0Ah, then terminate with ASC II code 0Ah,set remaining char = 20h)	20	00100000	
	107	6B	Manufacturer P/N(N=13 char-> 0Ah, then terminate with ASC II code 0Ah,set remaining char = 20h)	20	00100000	

APPENDIX A. Enhanced Extended Display Identification Data (EEDID™) 3/3

	Byte (Dec)	Byte (Hex)	Field Name and Comments	Value (Hex)	Value (Bin)
Timing Descriptor #4	108	6C	Flag	00	00000000
	109	6D	Flag	00	00000000
	110	6E	Flag	00	00000000
	111	6F	Data Type Tag (ASCII String)	FE	11111110
	112	70	Flag	00	00000000
	113	71	ASCII String L	4C	01001100
	114	72	ASCII String P	50	01010000
	115	73	ASCII String 1	31	00110001
	116	74	ASCII String 3	33	00110011
	117	75	ASCII String 3	33	00110011
	118	76	ASCII String W	57	01010111
	119	77	ASCII String H	48	01001000
	120	78	ASCII String 2	32	00110010
	121	79	ASCII String -	2D	00101101
	122	7A	ASCII String T	54	01010100
123	7B	ASCII String L	4C	01001100	
124	7C	ASCII String M	4D	01001101	
125	7D	ASCII String 4	34	00110100	
Checksum	126	7E	Extension flag (# of optional 128 panel ID extension block to follow, Typ = 0)	00	00000000
	127	7F	Check Sum (The 1-byte sum of all 128 bytes in this panel ID block shall = 0)	57	01010111

APPENDIX B. Schematics of Circuit 1/2

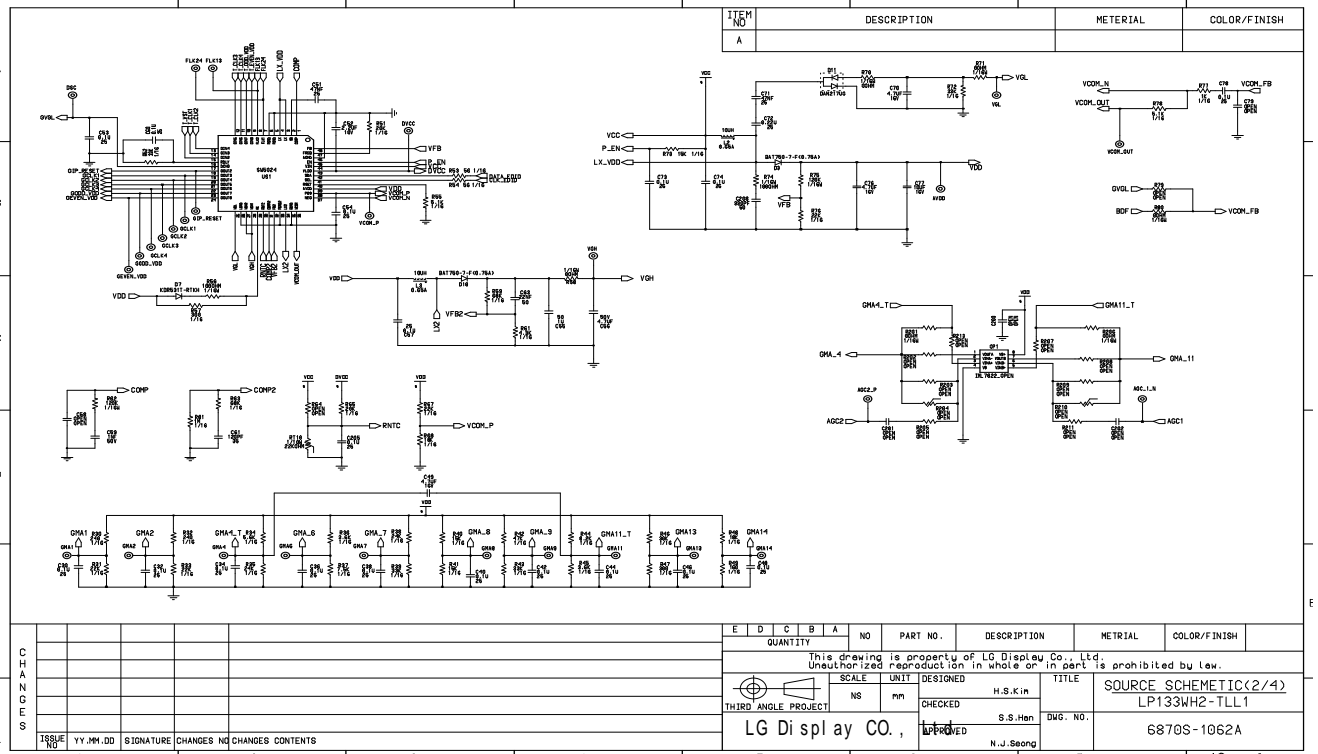
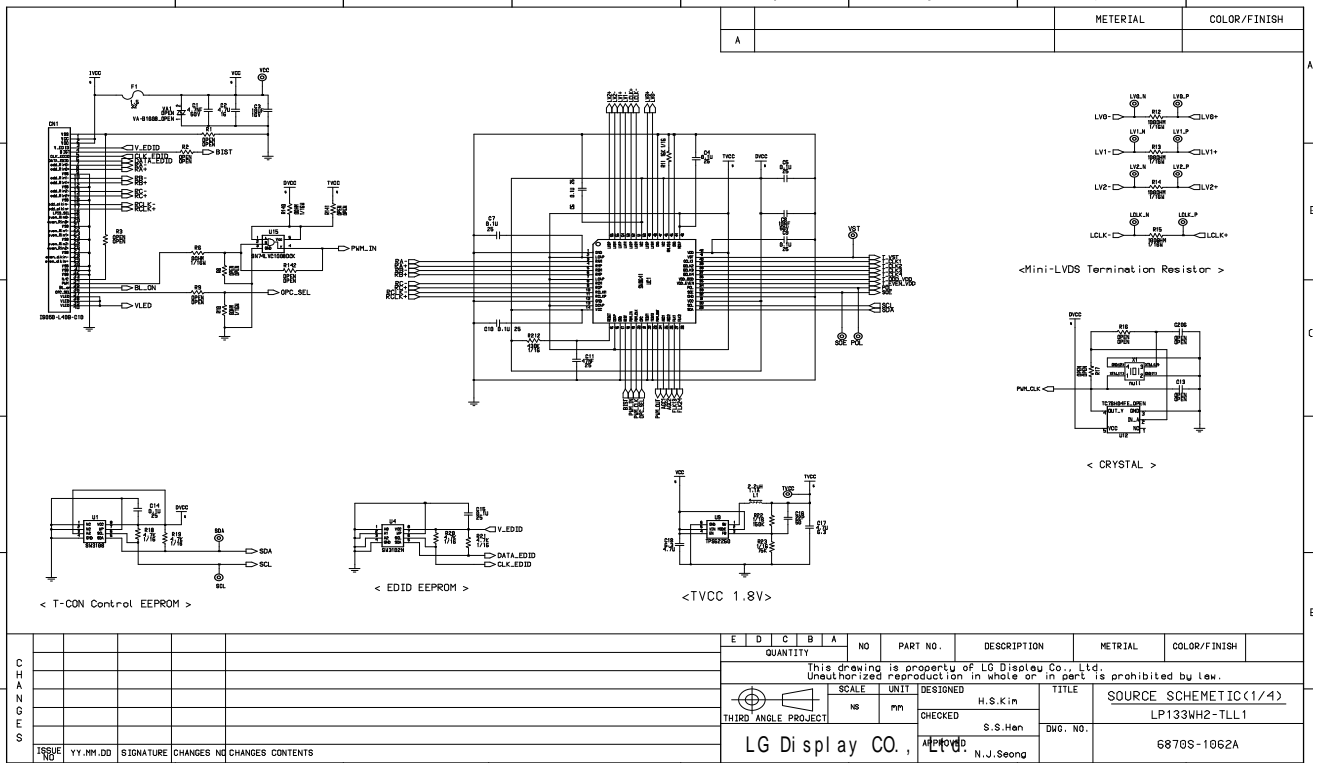

APPENDIX B. Schematics of Circuit 2/2

ITEM NO	DESCRIPTION	MATERIAL	COLOR/FINISH
A			

E	D	C	B	A	NO	PART NO.	DESCRIPTION	MATERIAL	COLOR/FINISH
QUANTITY									
This drawing is property of LG Display Co., Ltd. Unauthorized reproduction in whole or in part is prohibited by law.									
SCALE		UNIT		DESIGNED		TITLE			
THIRD ANGLE PROJECT		NS		mm		H.S.K.in		SOURCE SCHEMATIC(3/4)	
						CHECKED		DWG. NO.	
						S.S.Hen		LP133WH2-TLL1	
						APPROVED		6870S-1062A	
						N.J.Seong			

ITEM NO	DESCRIPTION	MATERIAL	COLOR/FINISH
A			

E	D	C	B	A	NO	PART NO.	DESCRIPTION	MATERIAL	COLOR/FINISH
QUANTITY									
This drawing is property of LG Display Co., Ltd. Unauthorized reproduction in whole or in part is prohibited by law.									
SCALE		UNIT		DESIGNED		TITLE			
THIRD ANGLE PROJECT		mm		H.S.K.in		SOURCE SCHEMATIC(4/4)			
						CHECKED		DWG. NO.	
						S.S.Hen		LP133WH2-TLL1	
						APPROVED		6870S-1062A	
						N.J.Seong			

APPENDIX C. PCB layout of Circuit

- 1 Layer

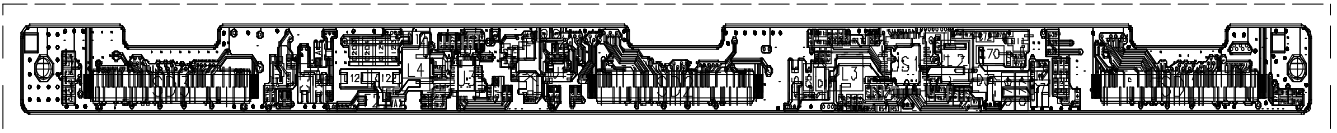

- 2 Layer

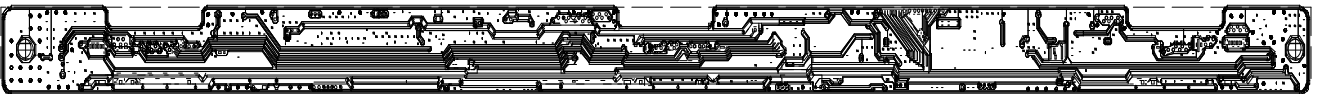

- 3 Layer



- 4 Layer

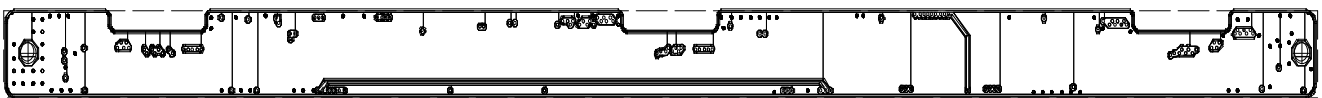

- 5 Layer

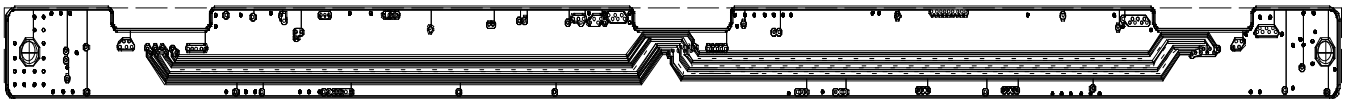

- 6 Layer

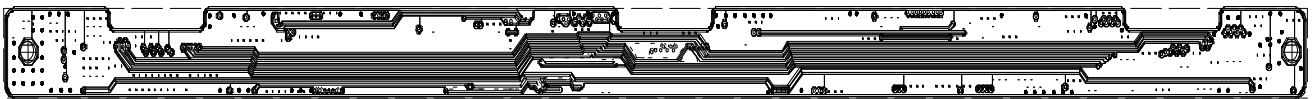

- 7 Layer

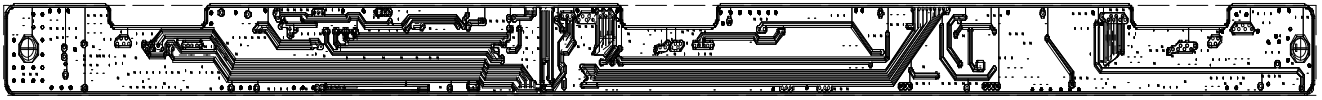

- 8 Layer

