



LP140WD2
Liquid Crystal Display

Product Specification

SPECIFICATION FOR APPROVAL

() Preliminary Specification

(◆) Final Specification

Title	14.0"W HD+ TFT LCD
-------	--------------------

Customer	HP
MODEL	

SUPPLIER	LG Display Co., Ltd.
*MODEL	LP140WD2
Suffix	TLE1

*When you obtain standard approval,
please use the above model name without suffix

APPROVED BY	SIGNATURE
/	_____
/	_____
/	_____

Please return 1 copy for your confirmation with your signature and comments.

APPROVED BY	SIGNATURE
S. R. Kim / S.Manager	_____
REVIEWED BY	
M. J. Lee / Manager	_____
PREPARED BY	
C. W. Lee / Engineer	
H. J. Lee / Engineer	_____

**Products Engineering Dept.
LG Display Co., Ltd**



LP140WD2
Liquid Crystal Display

Product Specification

Contents

No	ITEM	Page
	COVER	1
	CONTENTS	2
	RECORD OF REVISIONS	3
1	GENERAL DESCRIPTION	4
2	ABSOLUTE MAXIMUM RATINGS	5
3	ELECTRICAL SPECIFICATIONS	
3-1	ELECTRICAL CHARACTERISTICS	6-7
3-2	INTERFACE CONNECTIONS	8
3-3	LVDS SIGNAL TIMING SPECIFICATIONS	9-10
3-4	SIGNAL TIMING SPECIFICATIONS	11
3-5	SIGNAL TIMING WAVEFORMS	11
3-6	COLOR INPUT DATA REFERENCE	12
3-7	POWER SEQUENCE	13
4	OPTICAL SPECIFICATIONS	14-16
5	MECHANICAL CHARACTERISTICS	17-19
6	RELIABILITY	20
7	INTERNATIONAL STANDARDS	21
7-1	SAFETY	
7-2	EMC	
8	PACKING	22
8-1	DESIGNATION OF LOT MARK	
8-2	PACKING FORM	
8-3	LABEL DESCRIPTION	
9	PRECAUTIONS	23-24
A	APPENDIX A. Enhanced Extended Display Identification Data	25-27

1. General Description

The LP40WD2 is a Color Active Matrix Liquid Crystal Display with an integral LED backlight system. The matrix employs a-Si Thin Film Transistor as the active element. It is a transmissive type display operating in the normally white mode. This TFT-LCD has 14.0 inches diagonally measured active display area with HD+ resolution (1600 horizontal by 900 vertical pixel array). Each pixel is divided into Red, Green and Blue sub-pixels or dots which are arranged in vertical stripes. Gray scale or the brightness of the sub-pixel color is determined with a 6-bit gray scale signal for each dot, thus, presenting a palette of more than 262,144 colors. The LP140WD2 has been designed to apply the interface method that enables low power, high speed, low EMI. The LP140WD2 is intended to support applications where thin thickness, low power are critical factors and graphic displays are important. In combination with the vertical arrangement of the sub-pixels, the LP140WD2 characteristics provide an excellent flat display for office automation products such as Notebook PC.

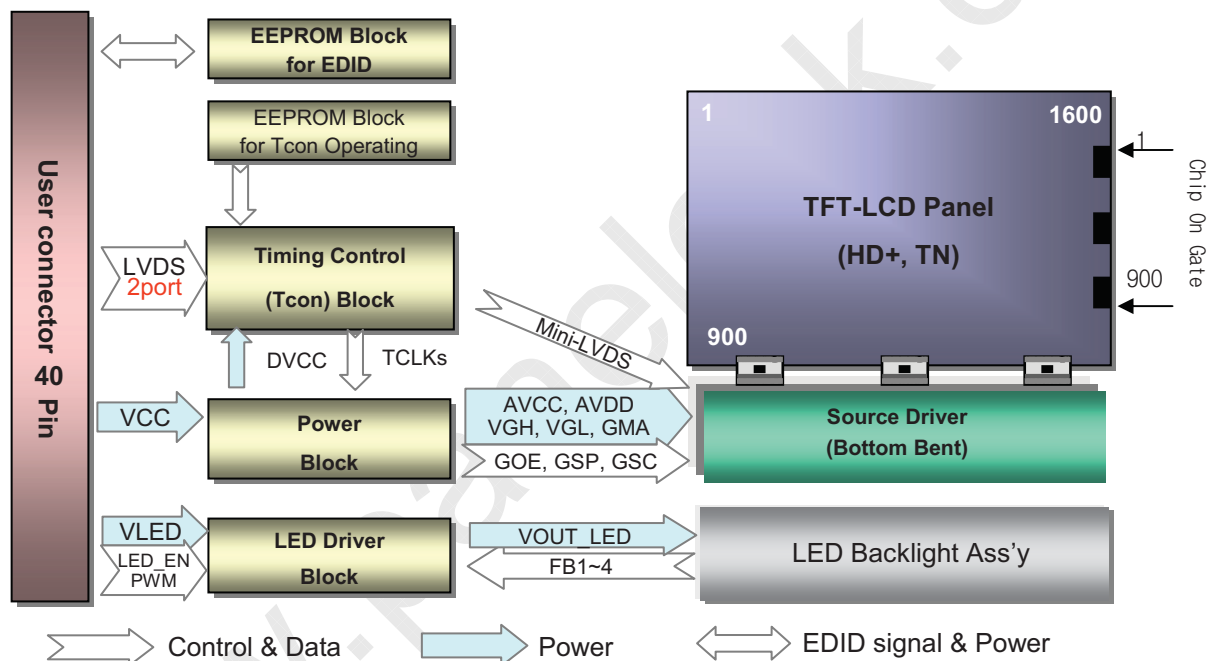

General Features

Active Screen Size	14.0 inches diagonal
Outline Dimension	320.4(H, typ) × 187.1(V, typ) × 3.4(D,max) [mm]
Pixel Pitch	0.1932mm × 0.1932 mm
Pixel Format	1600 horiz. By 900 vert. Pixels RGB strip arrangement
Color Depth	6-bit, 262,144 colors
Luminance, White	250 cd/m ² (Typ.5 point)
Power Consumption	Total 5.3 Watt (Typ.) @ mosaic., Logic input 1.2 Watt (Typ.), B/L input 4.1 Watt (Typ.)
Weight	310g (Max.)
Display Operating Mode	Transmissive mode, normally white
Surface Treatment	Anti-glare treatment of the front polarizer(3H)
RoHS Comply	Yes



LP140WD2
Liquid Crystal Display

Product Specification

2. Absolute Maximum Ratings

The following are maximum values which, if exceeded, may cause faulty operation or damage to the unit.

Table 1. ABSOLUTE MAXIMUM RATINGS

Parameter	Symbol	Values		Units	Notes
		Min	Max		
Power Input Voltage	VCC	-0.3	4.0	Vdc	at 25 ± 5°C
Operating Temperature	TOP	0	50	°C	1
Storage Temperature	HST	-20	60	°C	1
Operating Ambient Humidity	HOPE	10	90	%RH	1
Storage Humidity	HST	10	90	%RH	1

Note : 1. Temperature and relative humidity range are shown in the figure below.
Wet bulb temperature should be 39°C Max, and no condensation of water.

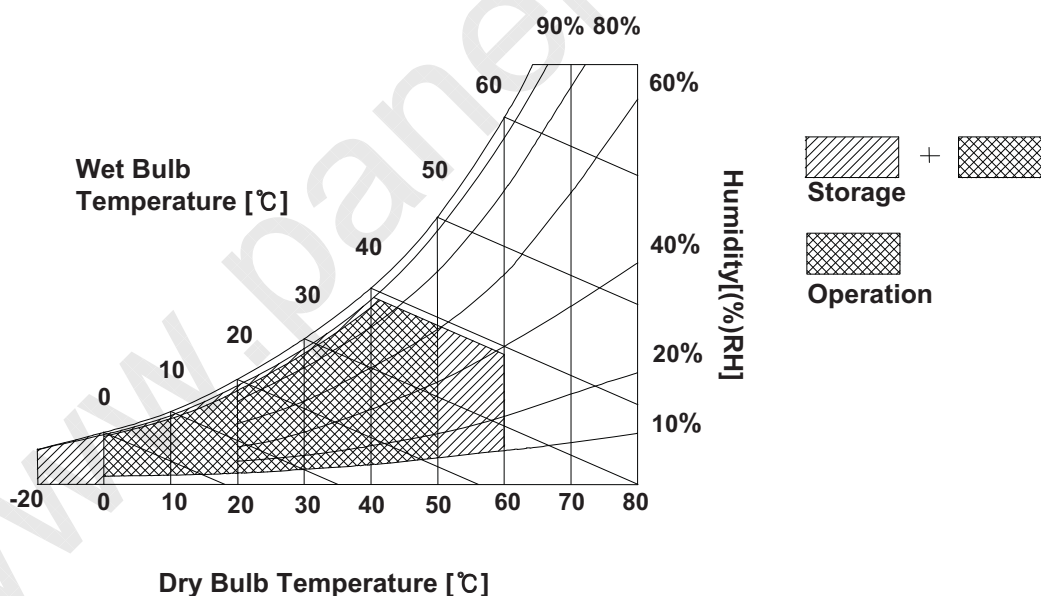



LP140WD2
Liquid Crystal Display

Product Specification

3. Electrical Specifications

3-1. Electrical Characteristics

The LP140WD2 requires two power inputs. The first logic is employed to power the LCD electronics and to drive the TFT array and liquid crystal. The second backlight is the input about LED BL with LED Driver.

Table 2. ELECTRICAL CHARACTERISTICS

Parameter	Symbol	Values			Unit	Notes
		Min	Typ	Max		
LOGIC :						
Power Supply Input Voltage	V _{CC}	3.0	3.3	3.6	V	1
Power Supply Input Current	Mosaic I _{CC}	-	360	450	mA	2
	Black I _{CC}	-	410	470	mA	
Power Consumption (Mosaic)	P _{CC}	-	1.2	1.5	W	2
Power Supply Inrush Current	I _{CC_P}	-	-	2000	mA	4
LVDS Impedance	Z _{LVDS}	90	100	110	Ω	5
BACKLIGHT : (with LED Driver)						
LED Power Input Voltage	V _{LED}	7.0	12.0	20.0	V	6
LED Power Input Current	I _{LED}	-	345	360	mA	7
LED Power Consumption	P _{LED}	-	4.1	4.3	W	7
LED Power Inrush Current	I _{LED_P}	-	-	2000	mA	8
PWM Duty Ratio		6	-	100	%	9
PWM Jitter	-	0	-	0.2	%	10
PWM Impedance	Z _{PWM}	20	40	60	kΩ	
PWM Frequency	F _{PWM}	200	-	2000	Hz	11
PWM High Level Voltage	V _{PWM_H}	3.0	-	5.3	V	
PWM Low Level Voltage	V _{PWM_L}	0	-	0.3	V	
LED_EN Impedance	Z _{PWM}	20	40	60	kΩ	
LED_EN High Voltage	V _{LED_EN_H}	3.0	-	5.3	V	
LED_EN Low Voltage	V _{LED_EN_L}	0	-	0.3	V	
Life Time		12,000	-	-	Hrs	12



LP140WD2
Liquid Crystal Display

Product Specification

Note)

1. The measuring position is the connector of LCM and the test conditions are under 25°C, $f_v = 60\text{Hz}$, Black pattern.
2. The specified I_{cc} current and power consumption are under the $V_{cc} = 3.3\text{V}$, 25°C, $f_v = 60\text{Hz}$ condition and Mosaic pattern.

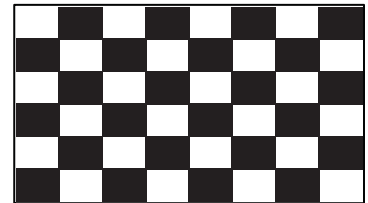

3. This Spec. is the max load condition for the cable impedance designing.
4. The below figures are the measuring V_{cc} condition and the V_{cc} control block LGD used. The V_{cc} condition is same as the minimum of T1 at Power on sequence.

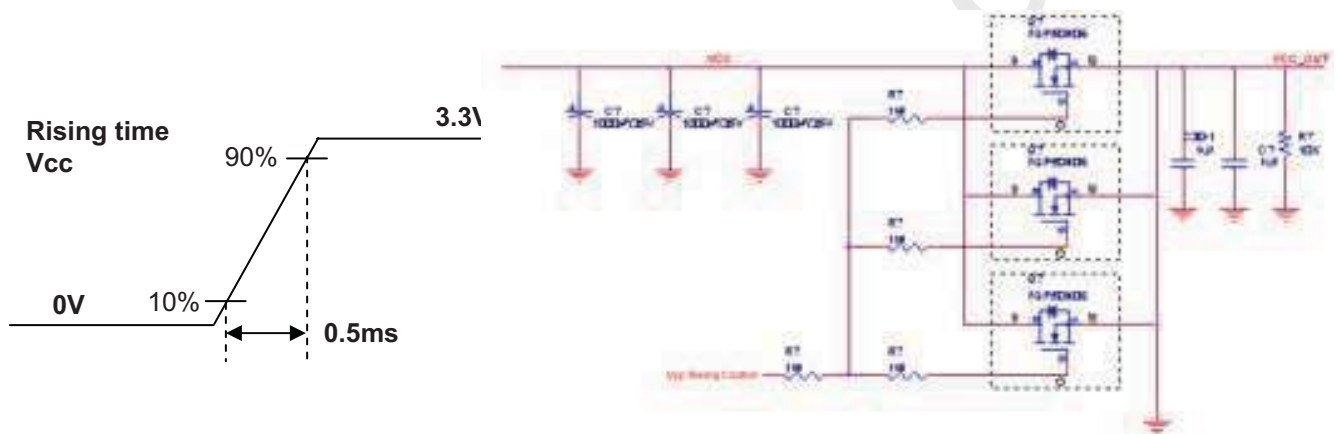

5. This impedance value is needed for proper display and measured from LVDS Tx to the mating connector.
6. The measuring position is the connector of LCM and the test conditions are under 25°C.
7. The current and power consumption with LED Driver are under the $V_{led} = 12.0\text{V}$, 25°C, Dimming of Max luminance and White pattern with the normal frame frequency operated(60Hz).
8. The below figures are the measuring V_{led} condition and the V_{led} control block LGD used. V_{LED} control block is same with V_{cc} control block.

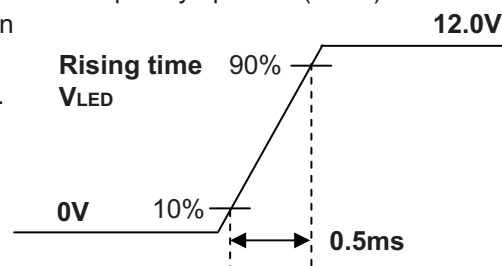

9. The operation of LED Driver below minimum dimming ratio may cause flickering or reliability issue.
10. If Jitter of PWM is bigger than maximum, it may induce flickering.
11. This Spec. is not effective at 100% dimming ratio as an exception because it has DC level equivalent to 0Hz. In spite of acceptable range as defined, the PWM Frequency should be fixed and stable for more consistent brightness control at any specific level desired.
12. The life time is determined as the time at which brightness of LCD is 50% compare to that of minimum value specified in table 7. under general user condition.



LP140WD2
Liquid Crystal Display

Product Specification

3-2. Interface Connections

This LCD employs two interface connections, a 40 pin connector used for the module electronics interface and the other connector used for the integral backlight system.

Table 3. MODULE CONNECTOR PIN CONFIGURATION (CN1)

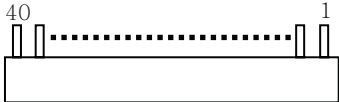
Pin	Symbol	Description	Notes
1	NC	No Connection	[Interface Chip] 1. LCD : SiW, SW0646(LCD Controller) Including LVDS Receiver. 2. System : SiW LVDSRx or equivalent * Pin to Pin compatible with LVDS
2	VCC	LCD Logic and driver power (3.3V Typ.)	
3	VCC	LCD Logic and driver power (3.3V Typ.)	
4	V EEDID	DDC Power (3.3V)	
5	NC	No Connection	
6	Cik EEDID	DDC Clock	
7	DATA EEDID	DDC Data	
8	ORX0-	Negative LVDS differential data input	[Connector] LSMtron GT05Q-40S-H10 or equivalent
9	ORX0+	Positive LVDS differential data input	
10	GND	LCM Ground	[Mating Connector] Mating of IPEX 20455-040 or equivalent
11	ORX1-	Negative LVDS differential data input	
12	ORX1+	Positive LVDS differential data input	[Connector pin arrangement] 
13	GND	LCM Ground	
14	ORX2-	Negative LVDS differential data input	[LCD Module Rear View]
15	ORX2+	Positive LVDS differential data input	
16	GND	LCM Ground	
17	ORXC-	Negative LVDS differential clock input	
18	ORXC+	Positive LVDS differential clock input	
19	GND	LCM Ground	
20	ERX0-	Negative LVDS differential data input	
21	ERX0+	Positive LVDS differential data input	
19	GND	LCM Ground	
23	ERX1-	Negative LVDS differential data input	
24	ERX1+	Positive LVDS differential data input	
19	GND	LCM Ground	
26	ERX2-	Negative LVDS differential data input	
27	ERX2+	Positive LVDS differential data input	
19	GND	LCM Ground	
29	ERXC-	Negative LVDS differential clock input	
30	ERXC+	Positive LVDS differential clock input	
31	GND	LCM Ground (LED Backlight Ground)	
32	GND	LCM Ground (LED Backlight Ground)	
33	GND	LCM Ground (LED Backlight Ground)	
34	NC	No Connection	
35	PWM	System PWM Signal input for dimming	
36	LED_EN	LED Backlight On/Off	
37	NC	No Connection	
38	VLED	LED Backlight Power (7V-21V)	
39	VLED	LED Backlight Power (7V-21V)	
40	VLED	LED Backlight Power (7V-21V)	



LP140WD2
Liquid Crystal Display

Product Specification

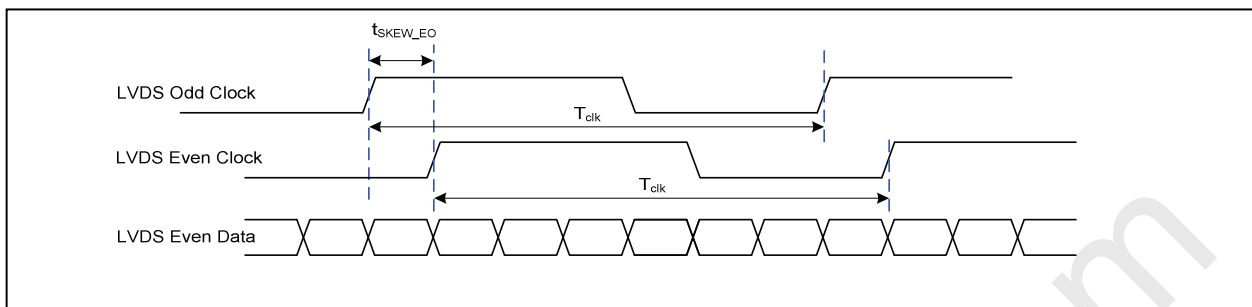

< Clock skew margin between channel >

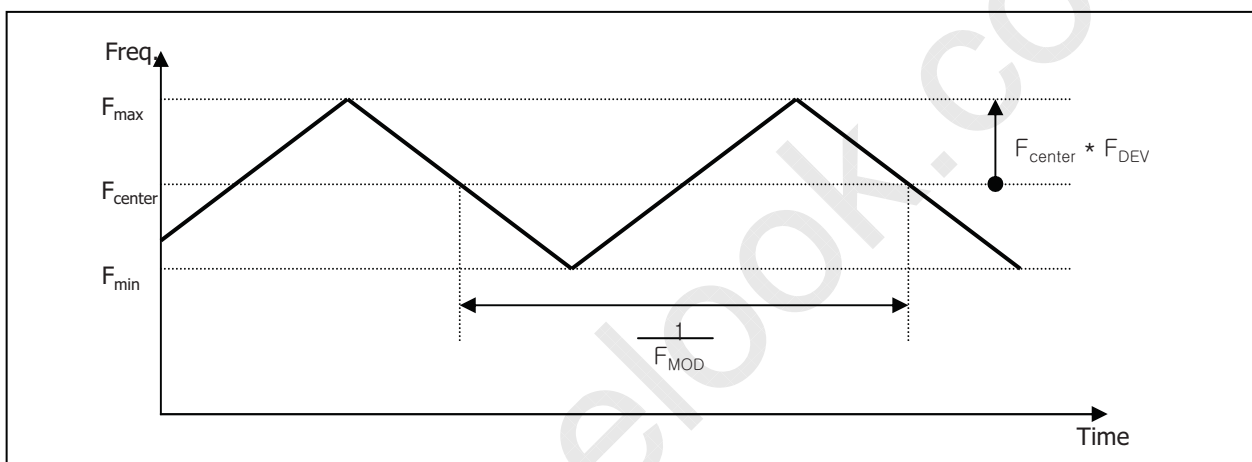

< Spread Spectrum >

3-3-3. Data Format

1) LVDS 2 Port

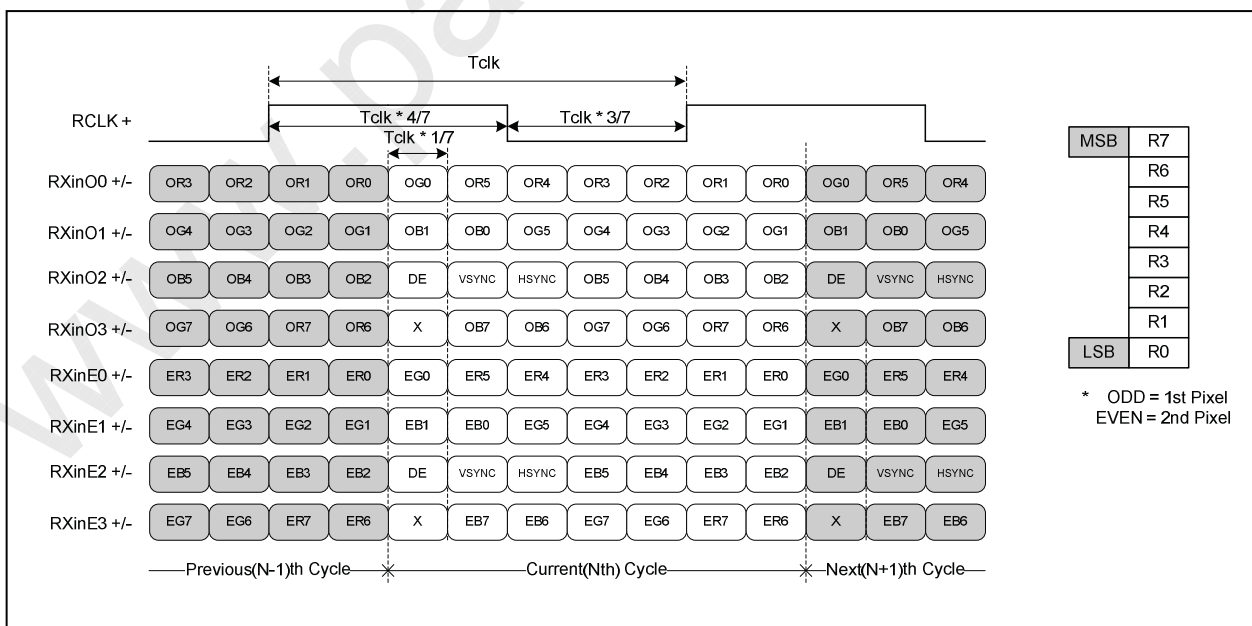

< LVDS Data Format >



LP140WD2
Liquid Crystal Display

Product Specification

3-4. Signal Timing Specifications

This is the signal timing required at the input of the User connector. All of the interface signal timing should be satisfied with the following specifications and specifications of LVDS Tx/Rx for its proper operation.

Table 4. TIMING TABLE

ITEM	Symbol	Min.	Typ.	Max.	Unit	Note	
DCLK	Frequency	f_{CLK}	-	61	-	MHz	2 Port
Hsync	Period	t_{HP}	1064	1088	1112	tCLK	2 Port
	Width	t_{WH}	48	48	48		
	Width-Active	t_{WHA}	800	800	800		
Vsync	Period	t_{VP}	936	936	936	tHP	
	Width	t_{WV}	5	5	5		
	Width-Active	t_{WVA}	900	900	900		
Data Enable	Horizontal back porch	t_{HBP}	140	160	180	tCLK	2 Port
	Horizontal front porch	t_{HFP}	76	80	84		
	Vertical back porch	t_{VBP}	28	28	28	tHP	
	Vertical front porch	t_{VFP}	3	3	3		

Appendix) All reliabilities are specified for timing specification based on refresh rate of 60 Hz. Even though actual performance in 50Hz and 40Hz for low power is displayed normally, remark and inform to user that display quality in 40 Hz and 50 Hz is out of guarantee range.

3-5. Signal Timing Waveforms

Condition : $V_{CC} = 3.3V$

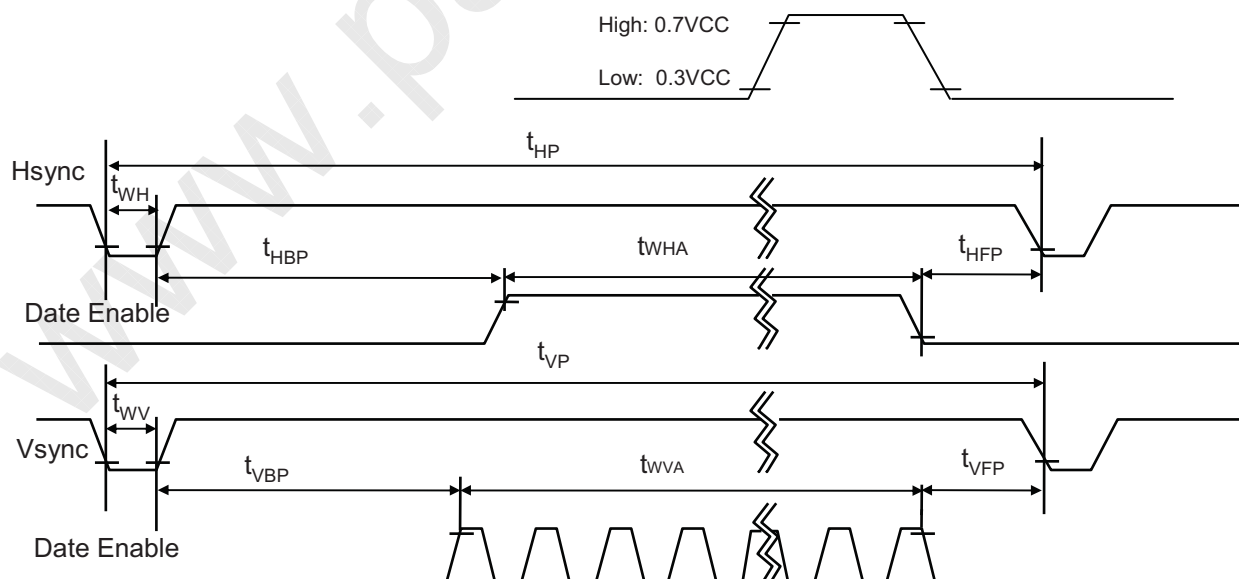



LP140WD2
Liquid Crystal Display

Product Specification

3-6. Color Input Data Reference

The brightness of each primary color (red, green and blue) is based on the 6-bit gray scale data input for the color ; the higher the binary input, the brighter the color. The table below provides a reference for color versus data input.

Table 5. COLOR DATA REFERENCE

Color		Input Color Data																	
		RED						GREEN						BLUE					
		MSB				LSB		MSB				LSB		MSB		LSB			
		R5	R4	R3	R2	R1	R0	G5	G4	G3	G2	G1	G0	B5	B4	B3	B2	B1	B0
Basic Color	Black	0	0	0	0	0	0	0	0	0	0	0	0	0	0	0	0	0	0
	Red	1	1	1	1	1	1	0	0	0	0	0	0	0	0	0	0	0	0
	Green	0	0	0	0	0	0	1	1	1	1	1	1	0	0	0	0	0	0
	Blue	0	0	0	0	0	0	0	0	0	0	0	0	1	1	1	1	1	1
	Cyan	0	0	0	0	0	0	1	1	1	1	1	1	1	1	1	1	1	1
	Magenta	1	1	1	1	1	1	0	0	0	0	0	0	1	1	1	1	1	1
	Yellow	1	1	1	1	1	1	1	1	1	1	1	1	0	0	0	0	0	0
	White	1	1	1	1	1	1	1	1	1	1	1	1	1	1	1	1	1	1
RED	RED (00)	0	0	0	0	0	0	0	0	0	0	0	0	0	0	0	0	0	0
	RED (01)	0	0	0	0	0	1	0	0	0	0	0	0	0	0	0	0	0	0
	
	RED (62)	1	1	1	1	1	0	0	0	0	0	0	0	0	0	0	0	0	0
	RED (63)	1	1	1	1	1	1	0	0	0	0	0	0	0	0	0	0	0	0
GREEN	GREEN (00)	0	0	0	0	0	0	0	0	0	0	0	0	0	0	0	0	0	0
	GREEN (01)	0	0	0	0	0	0	0	0	0	0	0	1	0	0	0	0	0	0
	
	GREEN (62)	0	0	0	0	0	0	1	1	1	1	1	0	0	0	0	0	0	0
	GREEN (63)	0	0	0	0	0	0	1	1	1	1	1	1	0	0	0	0	0	0
BLUE	BLUE (00)	0	0	0	0	0	0	0	0	0	0	0	0	0	0	0	0	0	0
	BLUE (01)	0	0	0	0	0	0	0	0	0	0	0	0	0	0	0	0	0	1
	
	BLUE (62)	0	0	0	0	0	0	0	0	0	0	0	0	1	1	1	1	1	0
	BLUE (63)	0	0	0	0	0	0	0	0	0	0	0	0	1	1	1	1	1	1



LP140WD2
Liquid Crystal Display

Product Specification

3-7. Power Sequence

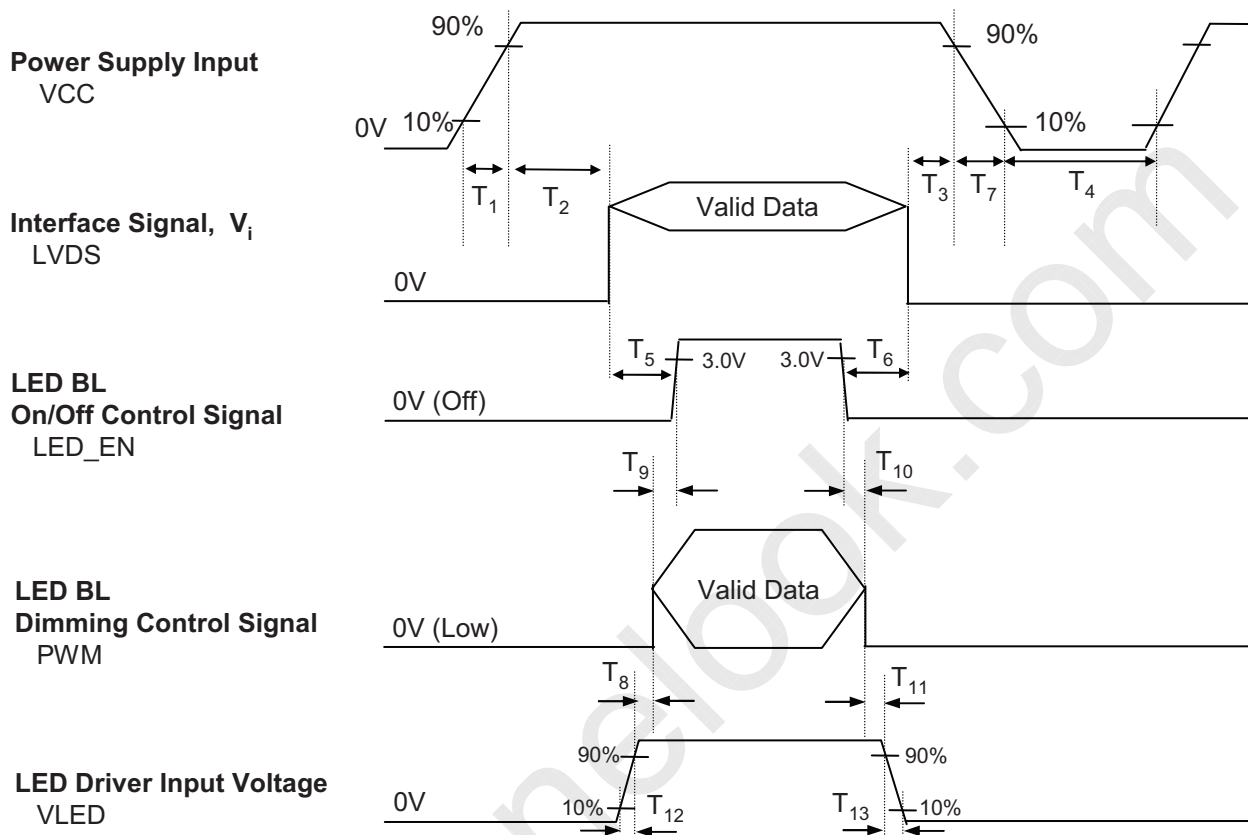

Table 6. POWER SEQUENCE TABLE

Logic Parameter	Value			Units	LED Parameter	Value			Units
	Min.	Typ.	Max.			Min.	Typ.	Max.	
T ₁	0.5	-	10	ms	T ₈	10	-	-	ms
T ₂	0	-	50	ms	T ₉	0	-	-	ms
T ₃	0	-	50	ms	T ₁₀	0	-	-	ms
T ₄	400	-	-	ms	T ₁₁	10	-	-	ms
T ₅	200	-	-	ms	T ₁₂	0.5	-	-	ms
T ₆	200	-	-	ms	T ₁₃	0	-	5000	ms
T ₇	3	-	10	ms					

Note)

1. Do not insert the mating cable when system turn on.
2. Valid Data have to meet "3-3. LVDS Signal Timing Specifications"
3. LVDS, LED_EN and PWM need to be on pull-down condition on invalid status.
4. LGD recommend the rising sequence of VLED after the Vcc and valid status of LVDS turn on.

4. Optical Specification

Optical characteristics are determined after the unit has been 'ON' and stable for approximately 20 minutes in a dark environment at 25°C. The values specified are at an approximate distance 50cm from the LCD surface at a viewing angle of Φ and Θ equal to 0°.

FIG. 1 presents additional information concerning the measurement equipment and method.

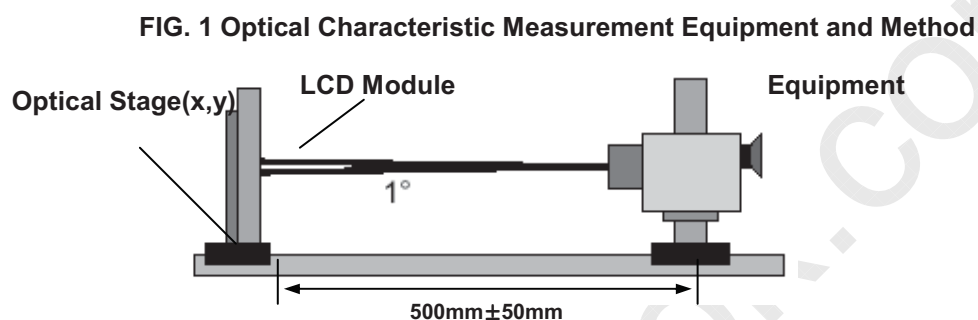

Table 7. OPTICAL CHARACTERISTICS

Ta=25°C, VCC=3.3V, fv=60Hz, fCLK= 61MHz

Parameter	Symbol	Values			Units	Notes
		Min	Typ	Max		
Contrast Ratio	CR	300	400	-		1
Surface Luminance, white	L _{WH}	210	250	-	cd/m ²	2
Luminance Variation(13P)	δ_{WHITE}	-	1.4	1.6		3
Response Time	Tr _R +Tr _D	-	16	25	ms	4
Color Coordinates						
RED	RX	0.610	0.640	0.670		
	RY	0.315	0.345	0.375		
GREEN	GX	0.305	0.335	0.365		
	GY	0.600	0.630	0.660		
BLUE	BX	0.120	0.150	0.180		
	BY	0.023	0.053	0.083		
WHITE	WX	0.283	0.313	0.343		
	WY	0.299	0.329	0.359		
Viewing Angle						
x axis, right($\Phi=0^\circ$)	Θ_r	65	70	-	degree	5
x axis, left ($\Phi=180^\circ$)	Θ_l	65	70	-	degree	
y axis, up ($\Phi=90^\circ$)	Θ_u	55	60	-	degree	
y axis, down ($\Phi=270^\circ$)	Θ_d	55	60	-	degree	
Gray Scale						6
Color Gamut	C/G	-	72	-	%	



LP140WD2
Liquid Crystal Display

Product Specification

Note)

1. Contrast Ratio(CR) is defined mathematically as

$$\text{Contrast Ratio} = \frac{\text{Surface Luminance with all white pixels}}{\text{Surface Luminance with all black pixels}}$$

2. Surface luminance is the average of 5 point across the LCD surface 50cm from the surface with all pixels displaying white. For more information see FIG 1.

$$L_{\text{WH}} = \text{Average}(L_1, L_2, \dots, L_5)$$

3. The variation in surface luminance, The panel total variation (δ_{WHITE}) is determined by measuring L_N at each test position 1 through 13 and then defined as followed numerical formula. For more information see FIG 2.

$$\delta_{\text{WHITE}} = \frac{\text{Maximum}(L_1, L_2, \dots, L_{13})}{\text{Minimum}(L_1, L_2, \dots, L_{13})}$$

4. Response time is the time required for the display to transition from white to black (rise time, Tr_R) and from black to white(Decay Time, Tr_D). For additional information see FIG 3.
5. Viewing angle is the angle at which the contrast ratio is greater than 10. The angles are determined for the horizontal or x axis and the vertical or y axis with respect to the z axis which is normal to the LCD surface. For more information see FIG 4.

6. Gray scale specification

* $f_V = 60\text{Hz}$

Gray Level	Luminance [%] (Typ)
L0	0.11
L7	0.86
L15	4.48
L23	11.2
L31	20.9
L39	34.1
L47	51.6
L55	73.1
L63	100



LP140WD2
Liquid Crystal Display

Product Specification

FIG. 2 Luminance

<Measuring point for Average Luminance & measuring point for Luminance variation>

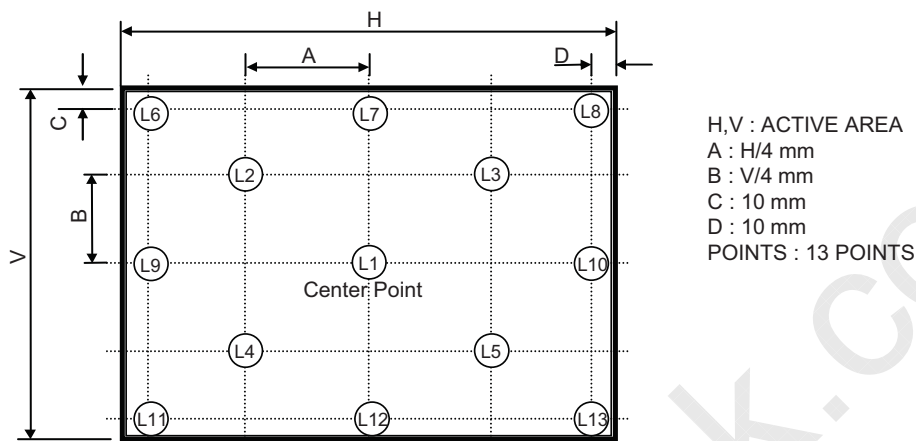

FIG. 3 Response Time

The response time is defined as the following figure and shall be measured by switching the input signal for “black” and “white”.

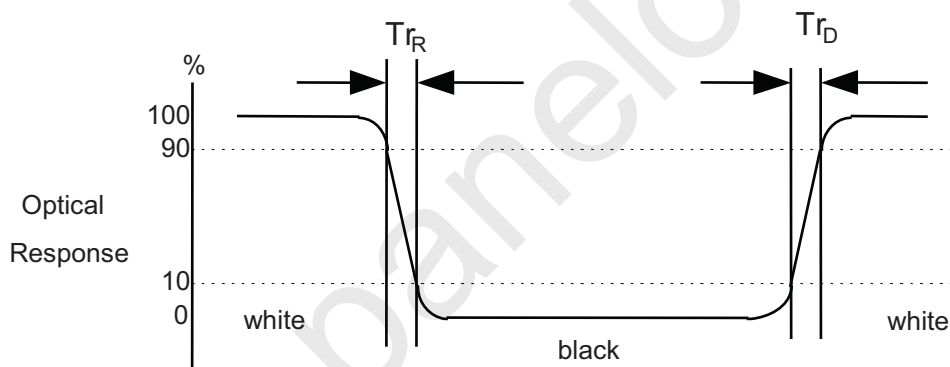
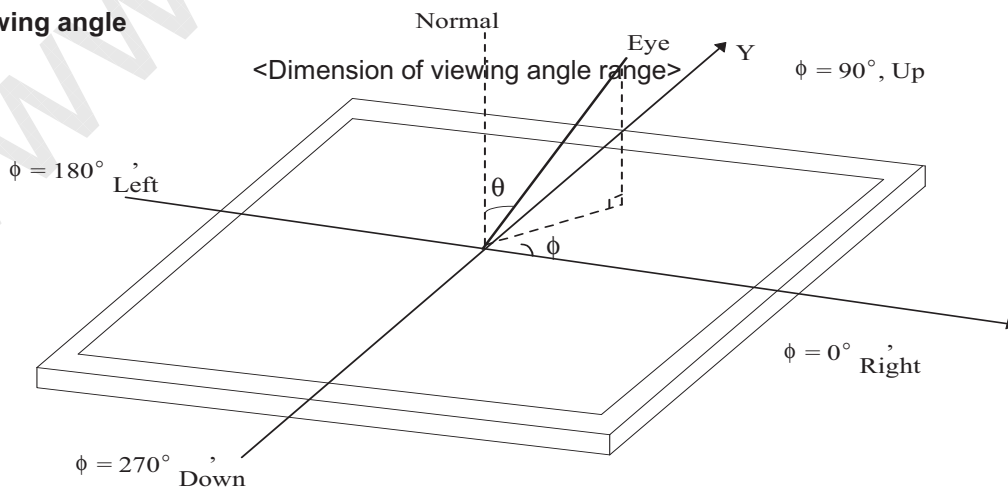

FIG. 4 Viewing angle





LP140WD2
Liquid Crystal Display

Product Specification

5. Mechanical Characteristics

The contents provide general mechanical characteristics for the model LP140WD2.
In addition the figures in the next page are detailed mechanical drawing of the LCD.

Outline Dimension	Horizontal	320.4± 0.5mm
	Vertical	187.1± 0.5mm
	Thickness	3.4mm (max)
Bezel Area (Pol. Size)	Horizontal	312.40 ± 0.5mm
	Vertical	176.95 ± 0.5mm
Active Display Area	Horizontal	309.12 mm
	Vertical	173.88 mm
Weight	310g (Max.)	
Surface Treatment	Anti glare treatment of the front polarizer(3H)	



LP140WD2
Liquid Crystal Display

Product Specification

<FRONT VIEW>

Note) Unit:[mm], General tolerance: ± 0.5mm

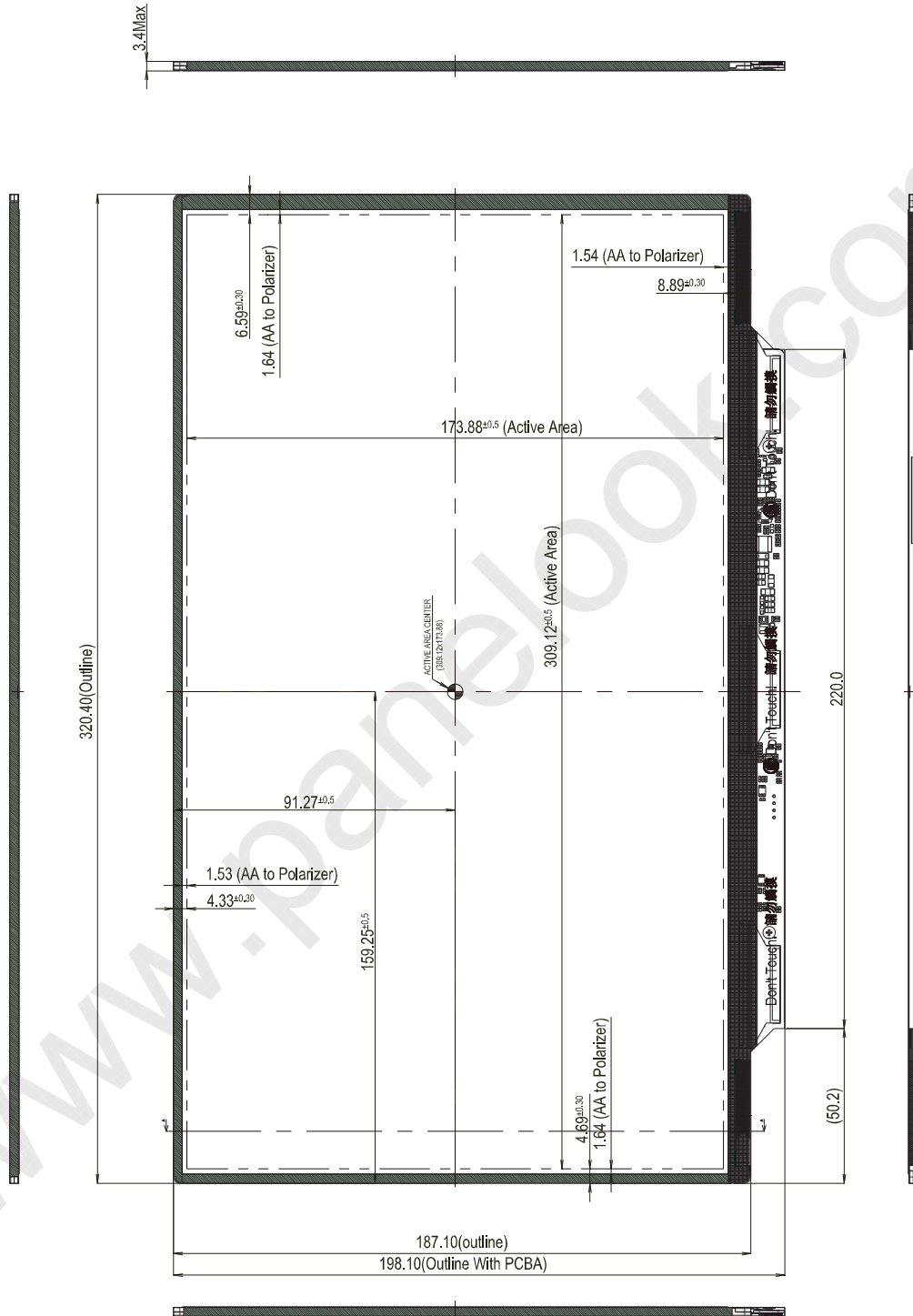



LP140WD2
Liquid Crystal Display

Product Specification

6. Reliability

Environment test condition

No.	Test Item	Conditions
1	High temperature storage test	Ta= 60°C, 240h
2	Low temperature storage test	Ta= -20°C, 240h
3	High temperature operation test	Ta= 50°C, 50%RH, 240h
4	Low temperature operation test	Ta= 0°C, 240h
5	Vibration test (non-operating)	Sine wave, 10 ~ 500 ~ 10Hz, 1.5G, 0.37oct/min 3 axis, 1hour/axis
6	Shock test (non-operating)	Half sine wave, 180G, 2ms one shock of each six faces(I.e. run 180G 2ms for all six faces)
7	Altitude operating storage / shipment	0 ~ 10,000 feet (3,048m) 24Hr 0 ~ 40,000 feet (12,192m) 24Hr

{ Result Evaluation Criteria }

There should be no change which might affect the practical display function when the display quality test is conducted under normal operating condition.



7. International Standards

7-1. Safety

- a) UL 60950-1, Second Edition, Underwriters Laboratories Inc.
Information Technology Equipment - Safety - Part 1 : General Requirements.
- b) CAN/CSA C22.2 No.60950-1-07, Second Edition, Canadian Standards Association.
Information Technology Equipment - Safety - Part 1 : General Requirements.
- c) EN 60950-1:2006 + A11:2009, European Committee for Electrotechnical Standardization (CENELEC).
Information Technology Equipment - Safety - Part 1 : General Requirements.
- d) IEC 60950-1:2005, Second Edition, The International Electrotechnical Commission (IEC).
Information Technology Equipment - Safety - Part 1 : General Requirements.

7-2. EMC

- a) ANSI C63.4 "American National Standard for Methods of Measurement of Radio-Noise Emissions from Low-Voltage Electrical and Electronic Equipment in the Range of 9 kHz to 40 GHz." American National Standards Institute (ANSI), 2003.
- b) CISPR 22 "Information technology equipment – Radio disturbance characteristics – Limit and methods of measurement." International Special Committee on Radio Interference (CISPR), 2005.
- c) CISPR 13 "Sound and television broadcast receivers and associated equipment – Radio disturbance characteristics – Limits and method of measurement." International Special Committee on Radio Interference (CISPR), 2006.

7-3. Environment

- a) RoHS, Directive 2002/95/EC of the European Parliament and of the council of 27 January 2003



LP140WD2
Liquid Crystal Display

Product Specification

8. Packing

8-1. Designation of Lot Mark

a) Lot Mark

A	B	C	D	E	F	G	H	I	J	K	L	M
---	---	---	---	---	---	---	---	---	---	---	---	---

A,B,C : SIZE(INCH)
E : MONTH

D : YEAR
F ~ M : SERIAL NO.

Note

1. YEAR

Year	2011	2012	2013	2014	2015	2016	2017	2018	2019	2020
Mark	A	B	C	D	E	F	G	H	J	K

2. MONTH

Month	Jan	Feb	Mar	Apr	May	Jun	Jul	Aug	Sep	Oct	Nov	Dec
Mark	1	2	3	4	5	6	7	8	9	A	B	C

b) Location of Lot Mark

Serial No. is printed on the label. The label is attached to the backside of the LCD module.
This is subject to change without prior notice.

8-2. Packing Form

a) Package quantity in one box : 20 pcs

b) Box Size : 478mm X 365mm X 288 mm

LP140WD2
Liquid Crystal Display

Product Specification

9. PRECAUTIONS

Please pay attention to the followings when you use this TFT LCD module.

9-1. MOUNTING PRECAUTIONS

- (1) You must mount a module using holes arranged in four corners or four sides.
- (2) You should consider the mounting structure so that uneven force (ex. Twisted stress) is not applied to the module. And the case on which a module is mounted should have sufficient strength so that external force is not transmitted directly to the module.
- (3) Please attach the surface transparent protective plate to the surface in order to protect the polarizer. Transparent protective plate should have sufficient strength in order to resist external force.
- (4) You should adopt radiation structure to satisfy the temperature specification.
- (5) Acetic acid type and chlorine type materials for the cover case are not desirable because the former generates corrosive gas of attacking the polarizer at high temperature and the latter causes circuit break by electro-chemical reaction.
- (6) Do not touch, push or rub the exposed polarizers with glass, tweezers or anything harder than HB pencil lead. And please do not rub with dust clothes with chemical treatment. Do not touch the surface of polarizer for bare hand or greasy cloth. (Some cosmetics are detrimental to the polarizer.)
- (7) When the surface becomes dusty, please wipe gently with absorbent cotton or other soft materials like chamois soaks with petroleum benzene. Normal-hexane is recommended for cleaning the adhesives used to attach front / rear polarizers. Do not use acetone, toluene and alcohol because they cause chemical damage to the polarizer.
- (8) Wipe off saliva or water drops as soon as possible. Their long time contact with polarizer causes deformations and color fading.
- (9) Do not open the case because inside circuits do not have sufficient strength.

9-2. OPERATING PRECAUTIONS

- (1) The spike noise causes the mis-operation of circuits. It should be lower than following voltage :
 $V = \pm 200\text{mV}$ (Over and under shoot voltage)
- (2) Response time depends on the temperature. (In lower temperature, it becomes longer.)
- (3) Brightness depends on the temperature. (In lower temperature, it becomes lower.)
And in lower temperature, response time (required time that brightness is stable after turned on) becomes longer.
- (4) Be careful for condensation at sudden temperature change. Condensation makes damage to polarizer or electrical contacted parts. And after fading condensation, smear or spot will occur.
- (5) When fixed patterns are displayed for a long time, remnant image is likely to occur.
- (6) Module has high frequency circuits. Sufficient suppression to the electromagnetic interference shall be done by system manufacturers. Grounding and shielding methods may be important to minimize the interference.

LP140WD2
Liquid Crystal Display

Product Specification

9-3. ELECTROSTATIC DISCHARGE CONTROL

Since a module is composed of electronic circuits, it is not strong to electrostatic discharge. Make certain that treatment persons are connected to ground through wrist band etc. And don't touch interface pin directly.

9-4. PRECAUTIONS FOR STRONG LIGHT EXPOSURE

Strong light exposure causes degradation of polarizer and color filter.

9-5. STORAGE

When storing modules as spares for a long time, the following precautions are necessary.

- (1) Store them in a dark place. Do not expose the module to sunlight or fluorescent light. Keep the temperature between 5°C and 35°C at normal humidity.
- (2) The polarizer surface should not come in contact with any other object.
It is recommended that they be stored in the container in which they were shipped.

9-6. HANDLING PRECAUTIONS FOR PROTECTION FILM

- (1) When the protection film is peeled off, static electricity is generated between the film and polarizer.
This should be peeled off slowly and carefully by people who are electrically grounded and with well ion-blown equipment or in such a condition, etc.
- (2) The protection film is attached to the polarizer with a small amount of glue. If some stress is applied to rub the protection film against the polarizer during the time you peel off the film, the glue is apt to remain on the polarizer.
Please carefully peel off the protection film without rubbing it against the polarizer.
- (3) When the module with protection film attached is stored for a long time, sometimes there remains a very small amount of glue still on the polarizer after the protection film is peeled off.
- (4) You can remove the glue easily. When the glue remains on the polarizer surface or its vestige is recognized, please wipe them off with absorbent cotton waste or other soft material like chamois soaked with normal-hexane.



LP140WD2
Liquid Crystal Display

Product Specification

APPENDIX A. Enhanced Extended Display Identification Data (EEDID™) 1/3

EDID Data for HP _ ver. 1.0

2011/8/20

	Byte (Dec)	Byte (Hex)	Field Name and Comments	Value (Hex)	Value (Bin)
Header	0	00	Header	00	00000000
	1	01	Header	FF	11111111
	2	02	Header	FF	11111111
	3	03	Header	FF	11111111
	4	04	Header	FF	11111111
	5	05	Header	FF	11111111
	6	06	Header	FF	11111111
Vendor / Product Version	7	07	Header	00	00000000
	8	08	ID Manufacture Name LGD	30	00110000
	9	09	ID Manufacture Name	E4	11100100
	10	0A	ID Product Code 0306h	06	00000110
	11	0B	(Hex. LSB first)	03	00000011
	12	0C	ID Serial No. - Optional ("00h" If not used, Number Only and LSB First)	00	00000000
	13	0D	ID Serial No. - Optional ("00h" If not used, Number Only and LSB First)	00	00000000
	14	0E	ID Serial No. - Optional ("00h" If not used, Number Only and LSB First)	00	00000000
	15	0F	ID Serial No. - Optional ("00h" If not used, Number Only and LSB First)	00	00000000
	16	10	Week of Manufacture - Optinal 00 weeks	00	00000000
Display Parameters	17	11	Year of Manufacture 2011 years	15	00010101
	18	12	EDID structure version # = 1	01	00000001
	19	13	EDID revision # = 4	04	00000100
	20	14	Video input Definition = Input is a Digital Video signal Interface , Colo Bit Depth : 6 Bits per Primary Color , Digital Video Interface Standard Supported: Digital Interface is not defined	90	10010000
	21	15	Horizontal Screen Size (Rounded cm) = 31 cm31 cm	1F	00011111
	22	16	Vertical Screen Size (Rounded cm) = 17 cm17 cm	11	00010001
	23	17	Display Transfer Characteristic (Gamma) = (gamma*100)-100 = Example:(2.2*100)-100=120 = 2.2 Gamm	78	01111000
	24	18	Feature Support [Display Power Management(DPM) : Standby Mode is not supported, Suspend Mode is not supported, Active Off = Very Low Power is not supported ,Supported Color Encoding Formats : RGB 4:4:4 ,Other Feature Support Flags : No_sRGB, Preferred Timing Mode, No_Display is continuous frequency (Multi-mode Base EDID and Extension Block).]	02	00000010
Panel Color Coordinates	25	19	Red/Green Low Bits (RxRy/GxGy)	43	01000011
	26	1A	Blue/White Low Bits (BxBy/WxWy)	45	01000101
	27	1B	Red X Rx = 0.591	97	10010111
	28	1C	Red Y Ry = 0.348	59	01011001
	29	1D	Green X Gx = 0.340	57	01010111
	30	1E	Green Y Gy = 0.558	8E	10001110
	31	1F	Blue X Bx = 0.157	28	00101000
	32	20	Blue Y By = 0.129	21	00100001
	33	21	White X Wx = 0.313	50	01010000
	34	22	White Y Wy = 0.329	54	01010100
Established Timings	35	23	Established timing 1 (Optional_00h if not used)	00	00000000
	36	24	Established timing 2 (Optional_00h if not used)	00	00000000
	37	25	Manufacturer's timings (Optional_00h if not used)	00	00000000
Standard Timing ID	38	26	Standard timing ID1 (Optional_01h if not used)	01	00000001
	39	27	Standard timing ID1 (Optional_01h if not used)	01	00000001
	40	28	Standard timing ID2 (Optional_01h if not used)	01	00000001
	41	29	Standard timing ID2 (Optional_01h if not used)	01	00000001
	42	2A	Standard timing ID3 (Optional_01h if not used)	01	00000001
	43	2B	Standard timing ID3 (Optional_01h if not used)	01	00000001
	44	2C	Standard timing ID4 (Optional_01h if not used)	01	00000001
	45	2D	Standard timing ID4 (Optional_01h if not used)	01	00000001
	46	2E	Standard timing ID5 (Optional_01h if not used)	01	00000001
	47	2F	Standard timing ID5 (Optional_01h if not used)	01	00000001
	48	30	Standard timing ID6 (Optional_01h if not used)	01	00000001
	49	31	Standard timing ID6 (Optional_01h if not used)	01	00000001

Ver. 1.0

Dec. 21, 2011

25 / 27



LP140WD2
Liquid Crystal Display

Product Specification

APPENDIX A. Enhanced Extended Display Identification Data (EEDID™) 2/3

	Byte (Dec)	Byte (Hex)	Field Name and Comments	Value (Hex)	Value (Bin)	
Timing Descriptor #1	54	36	Pixel Clock/10,000 (LSB)	122 MHz @ 59.9Hz	A8	10101000
	55	37	Pixel Clock/10,000 (MSB)		2F	00101111
	56	38	Horizontal Active (lower 8 bits)	1600 Pixels	40	01000000
	57	39	Horizontal Blanking(Thp-HA) (lower 8 bits)	576 Pixels	40	01000000
	58	3A	Horizontal Active / Horizontal Blanking(Thp-HA) (upper 4:4bits)		62	01100010
	59	3B	Vertical Active	900 Lines	84	10000100
	60	3C	Vertical Blanking (Tvp-HA) (DE Blanking typ.for DE only panels)	36 Lines	24	00100100
	61	3D	Vertical Active : Vertical Blanking (Tvp-HA) (upper 4:4bits)		30	00110000
	62	3E	Horizontal Sync. Offset (Thfp)	160 Pixels	A0	10100000
	63	3F	Horizontal Sync Pulse Width (HSPW)	96 Pixels	60	01100000
	64	40	Vertical Sync Offset(Tvfp) : Sync Width (VSPW)	3 Lines : 5 Lines	35	00110101
	65	41	Horizontal Vertical Sync Offset/Width (upper 2bits)		00	00000000
	66	42	Horizontal Image Size (mm)	310 mm	36	00110110
	67	43	Vertical Image Size (mm)	174 mm	AE	10101110
	68	44	Horizontal Image Size / Vertical Image Size		10	00010000
69	45	Horizontal Border = 0 (Zero for Notebook LCD)		00	00000000	
70	46	Vertical Border = 0 (Zero for Notebook LCD)		00	00000000	
71	47	Non-interlace, Normal display, no stereo, Digital Separate [vsync_NEG, Hsync_NEG (outside of v-sync)		19	00011001	
Timing Descriptor #2	72	48	Pixel Clock/10,000 (LSB)	81.33 MHz @ 39.9Hz	C5	11000101
	73	49	Pixel Clock/10,000 (MSB)		1F	00011111
	74	4A	Horizontal Active (lower 8 bits)	1600 Pixels	40	01000000
	75	4B	Horizontal Blanking(Thp-HA) (lower 8 bits)	576 Pixels	40	01000000
	76	4C	Horizontal Active / Horizontal Blanking(Thp-HA) (upper 4:4bits)		62	01100010
	77	4D	Vertical Active	900 Lines	84	10000100
	78	4E	Vertical Blanking (Tvp-HA) (DE Blanking typ.for DE only panels)	36 Lines	24	00100100
	79	4F	Vertical Active : Vertical Blanking (Tvp-HA) (upper 4:4bits)		30	00110000
	80	50	Horizontal Sync. Offset (Thfp)	160 Pixels	A0	10100000
	81	51	Horizontal Sync Pulse Width (HSPW)	96 Pixels	60	01100000
	82	52	Vertical Sync Offset(Tvfp) : Sync Width (VSPW)	3 Lines : 5 Lines	35	00110101
	83	53	Horizontal Vertical Sync Offset/Width (upper 2bits)		00	00000000
	84	54	Horizontal Image Size (mm)	310 mm	36	00110110
	85	55	Vertical Image Size (mm)	174 mm	AE	10101110
	86	56	Horizontal Image Size / Vertical Image Size		10	00010000
87	57	Horizontal Border = 0 (Zero for Notebook LCD)		00	00000000	
88	58	Vertical Border = 0 (Zero for Notebook LCD)		00	00000000	
89	59	Non-interlace, Normal display, no stereo, Digital Separate [vsync_NEG, Hsync_NEG (outside of v-sync)		19	00011001	
Timing Descriptor #3	90	5A	Blank for nvDPS		00	00000000
	91	5B	Blank for nvDPS		00	00000000
	92	5C	Blank for nvDPS		00	00000000
	93	5D	Blank for nvDPS		00	00000000
	94	5E	Blank for nvDPS		00	00000000
	95	5F	Blank for nvDPS		00	00000000
	96	60	Blank for nvDPS		00	00000000
	97	61	Blank for nvDPS		00	00000000
	98	62	Blank for nvDPS		00	00000000
	99	63	Blank for nvDPS		00	00000000
	100	64	Blank for nvDPS		00	00000000
	101	65	Blank for nvDPS		00	00000000
	102	66	Blank for nvDPS		00	00000000
	103	67	Blank for nvDPS		00	00000000
104	68	Blank for nvDPS		00	00000000	
105	69	Blank for nvDPS		00	00000000	
106	6A	Blank for nvDPS		00	00000000	
107	6B	Blank for nvDPS		00	00000000	



LP140WD2
Liquid Crystal Display

Product Specification

APPENDIX A. Enhanced Extended Display Identification Data (EEDID™) 3/3

	Byte (Dec)	Byte (Hex)	Field Name and Comments	Value (Hex)	Value (Bin)
Timing Descriptor #4	108	6C	Detailed Timing Descriptions #4	00	00000000
	109	6D	Flag	00	00000000
	110	6E	Reserved	00	00000000
	111	6F	For Brightness Table and Power consumption	02	00000010
	112	70	Flag	00	00000000
	113	71	PWM % [7:0] @ Step 0 4 % @ 10 nit	0A	00001010
	114	72	PWM % [7:0] @ Step 5 23 % @ 60 nit	3A	00111010
	115	73	PWM % [7:0] @ Step 10 100 % @ 250 nit	FF	11111111
	116	74	Nits [7:0] @ Step 0	0A	00001010
	117	75	Nits [7:0] @ Step 5	3C	00111100
	118	76	Nits [7:0] @ Step 10	7D	01111101
	119	77	Panel Electronic Power @ 32 x 32 Chess Pattern = 1000 mW	19	00011001
	120	78	Backlight Power @ 60 nits = 1068 mW	1B	00011011
	121	79	Backlight Power @ Step 10 = 4068 mW	33	00110011
	122	7A	Nits @ 100% PWM Duty = 250 nit	7D	01111101
	123	7B	Flag	00	00000000
124	7C	Flag	00	00000000	
125	7D	Flag	00	00000000	
Checksum	126	7E	Extension flag (# of optional 128 panel ID extension block to follow, Typ = 0)	00	00000000
	127	7F	Check Sum (The 1-byte sum of all 128 bytes in this panel ID block shall = 0)	9C	10011100