

DATE: '07.03.06

Specification of 14.1" TFT/LCD MODEL: LP141WX1 (TLB5)

Prepared	Checked	Approved	
D.G. Choi /Eng. Dept. /Engineer	S.Y. Kim /Eng. Dept. /Manager	S.C. Yun /Eng. Dept. /Senior Mgr	Y.S. Jung /QA. Dept. /Senior Mgr

NOTICE of RECEIPT We accepted this specification. OME Operations, TOSHIBA Corp.			
Purchasing Dept.	Eng.	Senr. Eng.	Senr. Mgr
PC Hardware Dept.	Eng.	Senr. Eng.	Senr. Mgr

LG.Philips LCD.,Co.Ltd

Date: 2007.03.06

- CONTENTS -

Record of Revision	-----	3
1. Scope	-----	4
2. General Specifications	-----	4
2.1. Features		
2.2. Dimensional Outline		
3. Absolute Maximum Ratings	-----	9
3.1. Absolute Ratings of Environment		
3.2. Electrical Absolute Maximum		
3.3. Mechanical ratings		
3.4. The others		
4. Optical Characteristics	-----	16
4.1 Test Conditions		
4.2 Optical Specifications		
5. Electrical Characteristics	-----	21
5.1. TFT LCD module		
5.2. Backlight Unit		
5.3. Regulation		
6. Block Diagram	-----	27
7. Input Terminal Pin Assignment	-----	28
7.1 TFT LCD module		
7.2 Backlight Unit		
7.3 LVDS Transmitter		
7.4 Timing Diagrams of LVDS for Transmission		
7.5 Input Signal, Basic Display Colors and Gray Scale of Each Colors		
8. Interface timing	-----	33
8.1 Timing Parameters		
8.2 Timing diagrams of interface signal		
8.3 Power On / Off Sequence		
9. Cosmetic Specification	-----	35
9.1 Sampling		
9.2 Conditions of Inspections		
9.3 Defect modes		
9.4 Mechanical inspection		
9.5 Visual Inspection		
9.6 Electrical inspection		
10. Packing	-----	39
11. Labels and Lamp Ass'y Exchange	-----	41
12. General Precaution	-----	53
Appendix	-----	55

Record of Revision

Date	Rev. No.	Sheet(New)	Item	Old	New	Reason
06'.11.28	0.0	All				First Edition
07' 01.02	0.1	All	Mechanical Drawing		Updated	Gamma 2.2 Reference
		7,11,48,49	Toque Value	2.0kgf	2.5kgf	
		16	Chromaticity (Green)	Min./Max. +/- 0.0 3	Min./Max. +/- 0.02	
		17,21	Gray Level, Power Consumption		Updated	
		27	Lamp P/N		Updated	
		33	Interface Timing	No margin V _{syn} c	Marginal V _{sync}	
		34	Power Sequence	T7 : 400ms	T7 : 200 ms	
		42	Caution Texture		Updated	
		43,44	Back Light Repair Kit	G33C00041110	G33C00041110001	
		55 ~ 57	EEDID	Ver 0.0	Ver 0.1	
07' 01.23	0.2	5,6,8,25,43,45, 52	Lamp-Wire Fixing Tape		Updated	
		55 ~ 57	EEDID	Ver 0.1	Ver 0.2	
07'01.25	0.3	27	Lamp P/N	Panel supplier P/N -Harrison : 6912L-0389A - Sanken: 6912L-0210A	Lamp supplier P/N(M/N) -Harrison:(Model Name) MBTM18JB222BX313.5MWLEH_C - Sanken:1085- 0	
		39	Packing Weight (20 PCS Modules included)	9.9kg	9.8kg	
07'03.06	1.0 Final CAS	7	Gap between upper polarizer and case Top	-	Addition	
		16	Chromaticity (R,G,B)	Min./Max. +/- 0.0 2	Min./Max. +/- 0.03	
		37	Dot Inspection	-	Updated	
		5,6,8,25,43,45, 46,47,50,51,52	Mechanical Drawing	-	The position of "High Voltage caution" Label is changed,	
LG.Philips LCD.,Co.Ltd			Date: 2007.03.06			

1. Scope

This specification is applicable to LCD manufacturer's 35.8cm (14.1") diagonal size TFT-LCD module "LP141WX1(TLB5)" designed for Personal Computer.

2. General Specification

2.1. Features

Item	Specifications
Display area (Active area)	303.74 (W) × 189.84(H) (mm) (14.1 " diagonal)
Driving Method	TFT active matrix
Number of Pixels	1280 (W) × 800 (H) × R,G,B (XGA) (pixels) ¹⁾
Pixel pitch	0.2373 (H) × 0.2373 (V) (mm) ¹⁾
Pixel Arrangement	RGB vertical stripes ¹⁾
Display color	262,144 (colors)
Display Mode	Transmissive type, Normally white
Viewing Direction	6 o'clock (in direction of maximum contrast)
Surface Treatment	Anti-glare treatment of the front polarizer
Interface	LVDS 1Port
Backlight	Single cold-cathode fluorescent lamp for side lighting
Dimensional Outline	320.0 (H) × 206.0(V) × 5.5(D) mm (Max.)
Bezel Opening	307.76 (W) × 193.00 (H) (mm)
Weight	435g(Max.)

Note 1)

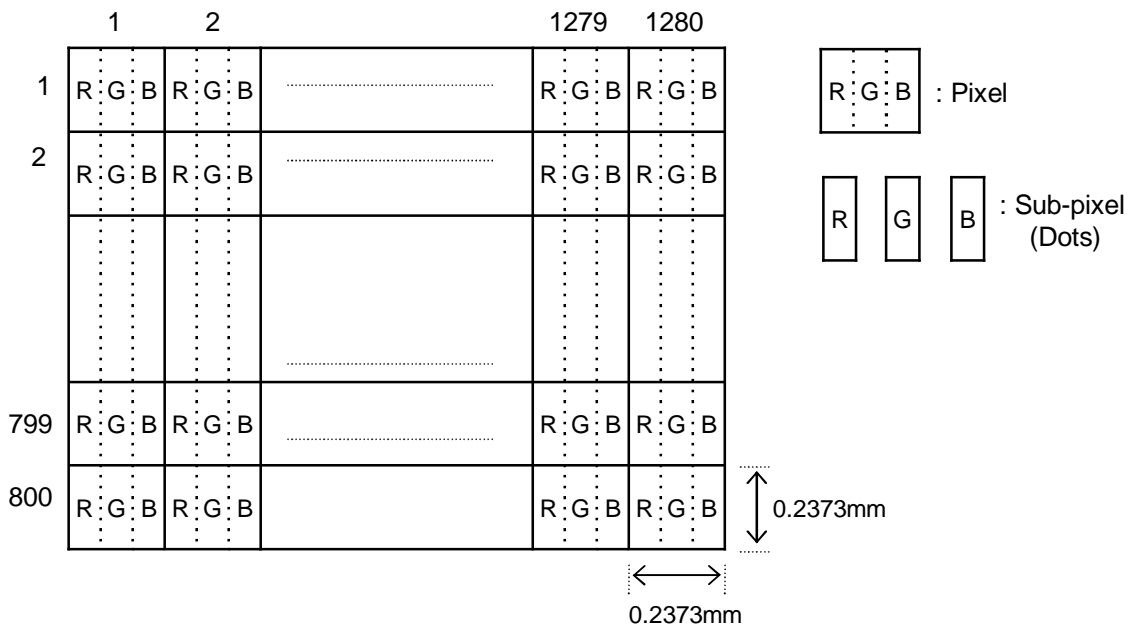

2.2. Dimensional Outline
(Front figure)

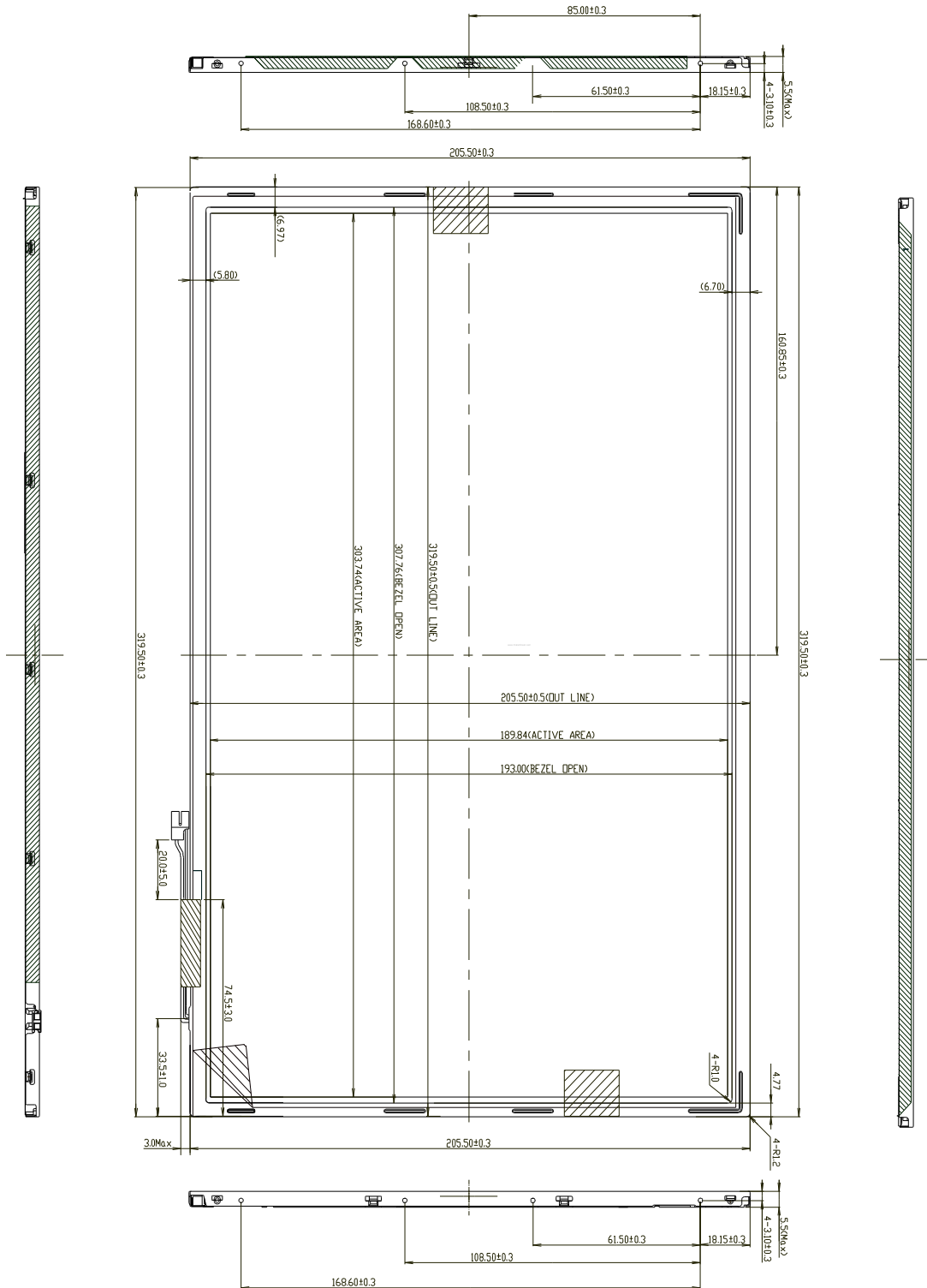

(Back figure)

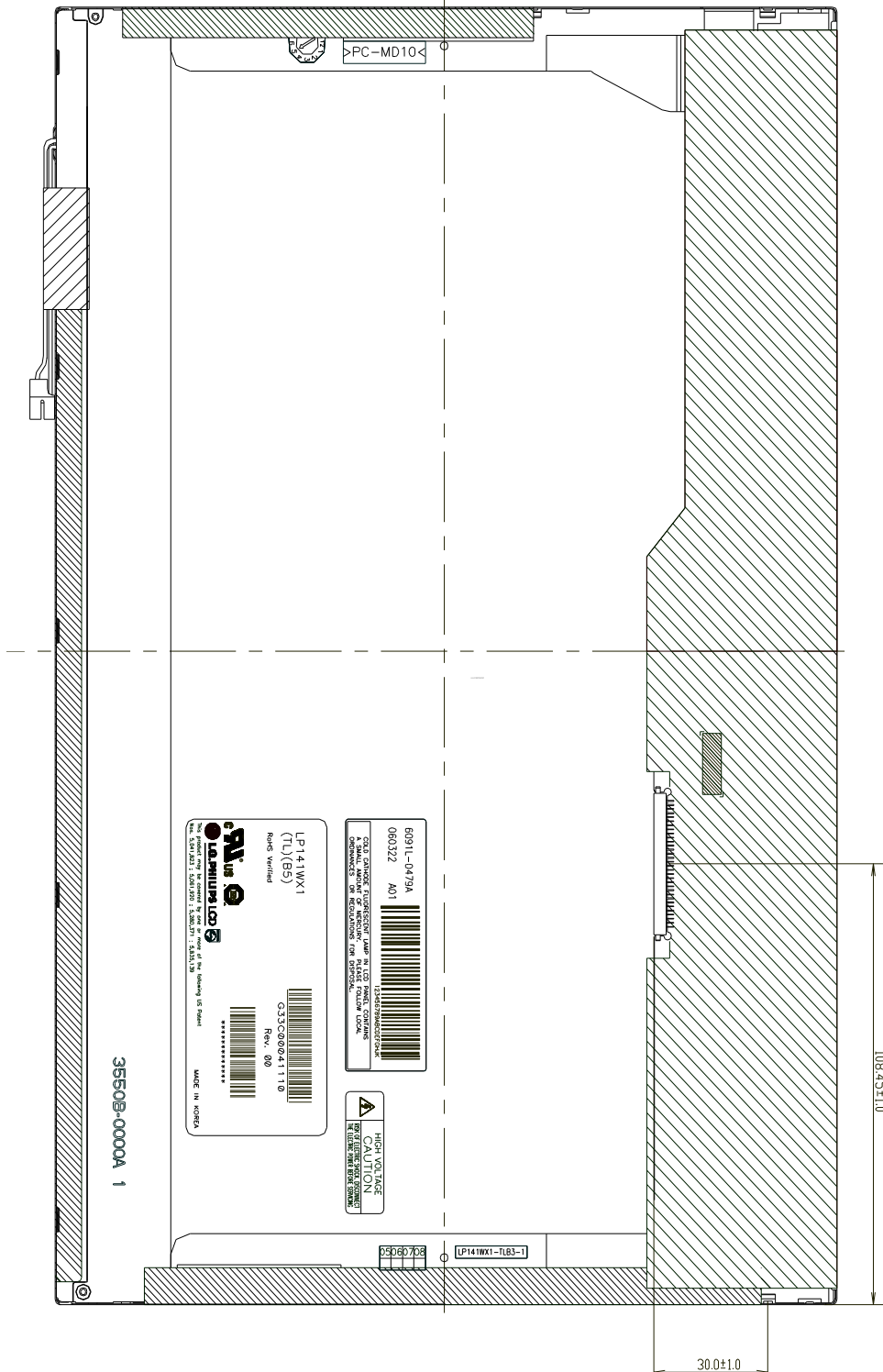

(Detail description of side mounting screw)

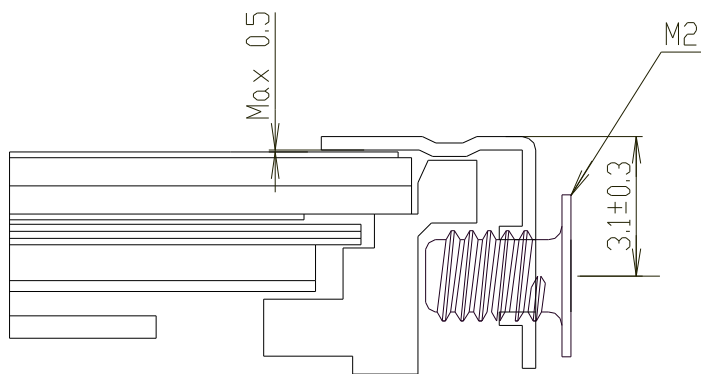

SECTION A-A

*SCREW(8ea) TORQUE : 2.5kgf.cm max

*Mounting SCREW Depth : 2.5mm max

*Gap Between Upper Pol and Case Top : 0.5mm max

(Detail description of height of LCM back side & TAB Zone)

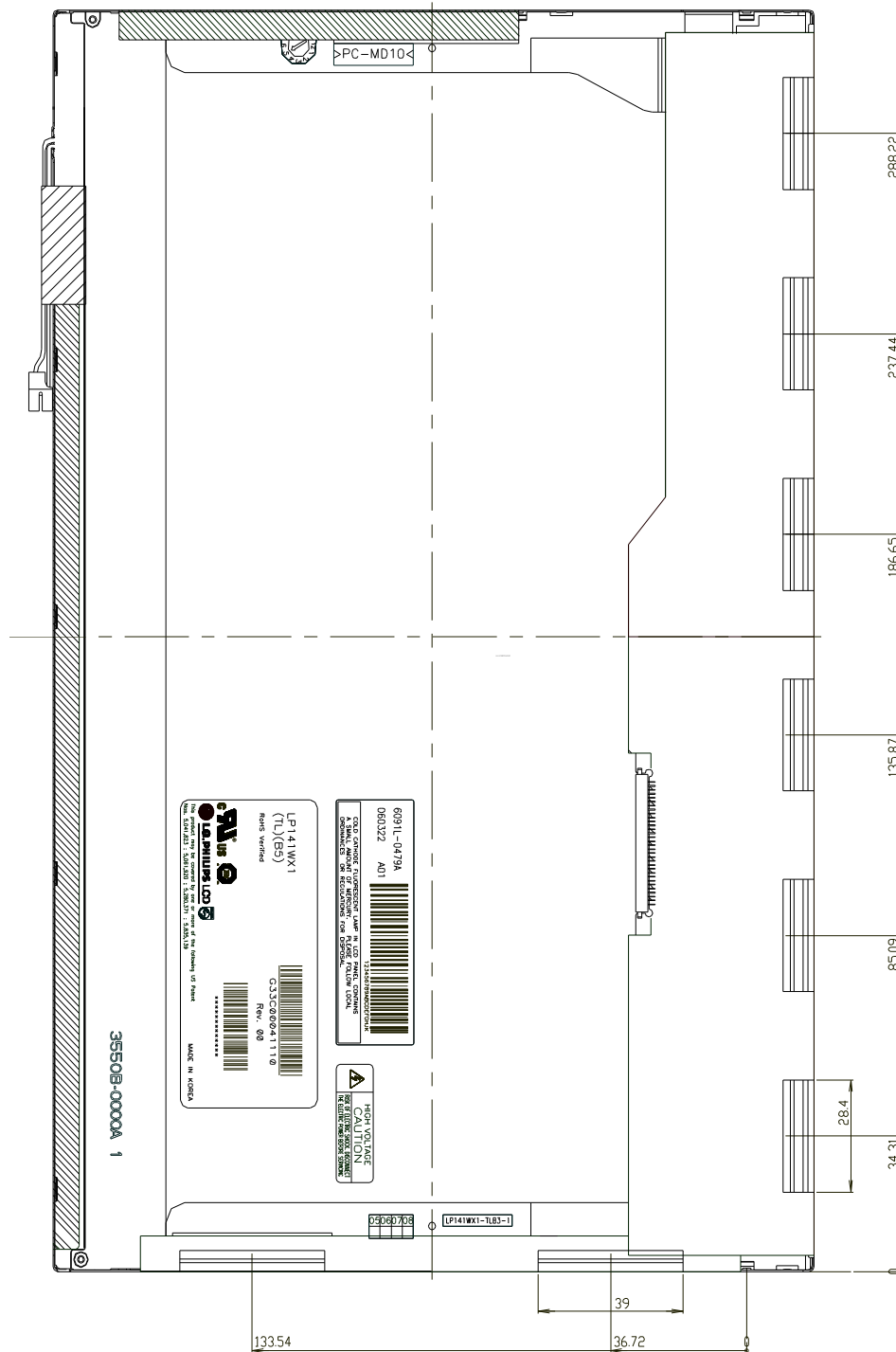

3. Absolute Maximum Ratings

3.1. Absolute Ratings of Environment

Item	Symbol	Min	Max	Unit	Note
Operating Ambient Temperature	TOP	0	+50	°C	(1)
Operating Temperature for Panel	-	0	+60	°C	(2)
Storage Temperature	TSTG	-20	+65	°C	(1)
Operating Ambient Humidity	HOPE	10	90	%RH	(1)
Storage Humidity	HSTG	10	90	%RH	(1)
Air Pressure	-	57	101.3	kPa	Operation
Air Pressure	-	12	101.3	kPa	Non-operation
Altitude	-	-	3	Km	Operation
Altitude	-	-	12	Km	Non-operation

Note 1) Temperature and relative humidity range are shown in the figure below.

Wet bulb temperature should be 39°C Max, and no condensation of water.

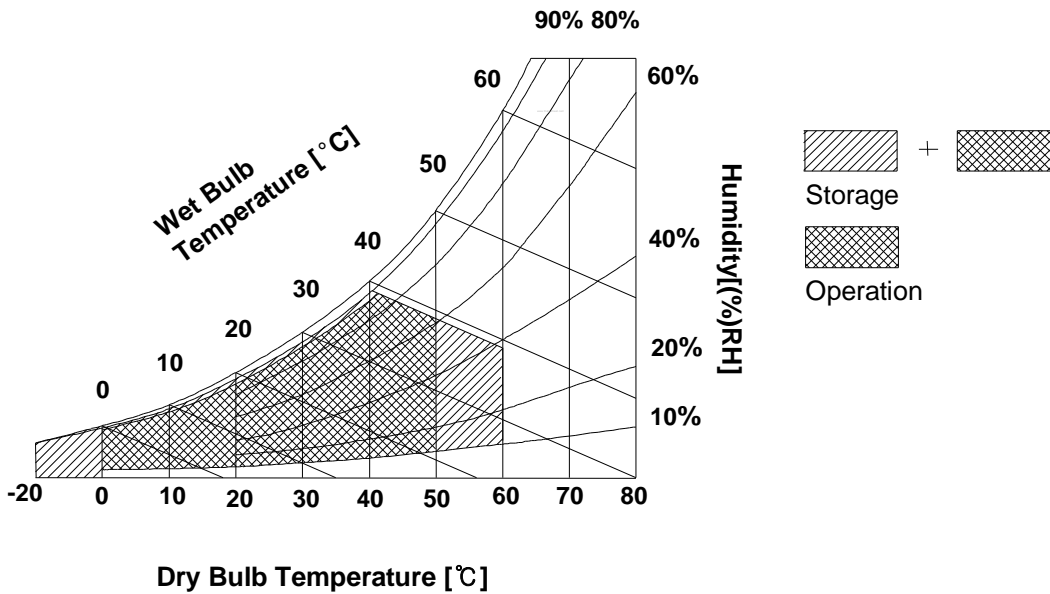

Note 2) The surface temperature caused by self heat radiation of cell itself is specified on this item.

3.2. Electrical Absolute Maximum

(1) TFT LCD Module

Item	Symbol	Min	Max	Unit	Note
Power Supply Voltage	V _{DD}	-0.3	+4.0	V	at 25 ± 5°C
Logic Input Voltage	V _{IN}	-0.3	V _{DD} +0.3	V	LVDS interface

(2) Back Light Unit

Item	Symbol	Min	Max	Unit	Note
Lamp Voltage	V _L	-	5000	V _{RMS}	Broken lamp Max Voltage
Lamp Current	I _L	2.0	7.0	mA _{RMS}	
Lamp Frequency	F _L	50	80	KHz	

3.3. Mechanical Ratings

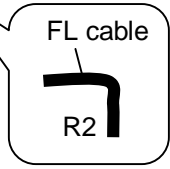
Test Item	Test Conditions		Note
Mechanical Vibration	Frequency Range 5 - 500 Hz, 14.7m/s ² 1.5G) constant, 0.5Hrs each axis (X, Y, Z direction).		Non Operation
	Frequency Range 5 - 500 Hz, 4.9m/s ² (0.5G) constant, 0.5Hrs each axis (X, Y, Z direction).		Operation
Mechanical Shock LCD fix condition -> See Note (2)	* 240G, Pulse width 2 ms, Sine Wave, ±X, ±Y, ±Z direction. 70G, Pulse width 11ms, Sine Wave ±X, ±Y, ±Z direction. * Note) Normal function is only checking points.		Non Operation
	98 m/s ² (10G), Pulse width 11 ms, Sine Wave, ±X, ±Y, ±Z direction.		Operation
Pressure Resistance -> See Note (1)	No Destruction with the force 196 N (20 kgf, 16 mm in diameter) to the display surface at the vertical direction.		Non Operation Fig 1-1 Fig 1-2 Fig 1-3
	No Destruction with the force 294.2 N (30 kgf, 30 mm in diameter) to the back of the display surface at the vertical direction. Only the breakage of below items will not happen after test. (Glass.Lamp & Circuit parts)		
Strength of FL Cable	Strength of Rotation force	Cable : No disconnection of cable to the 5 trial of 360 degree rotation. See a bended state of cable.	Non Operation 
	Lead Pull Test	Connector : No disconnection of cable to 10 trial of 180 degree rotation. See a bended state of cable. Soldering portion 29.4N(3.0kgf) 10mins *1.08mm Wire applied Connector : 12.9N (1.32kgf) 1 sec *1.08mm Wire applied	
Connector tension test	Input connector : With 50 times of connector trial there must be no damage to the shape and functionally. Back light connector : With 50 times of connector trial there must be no damage to the shape and functionally.		Non Operation
Assured torque value at side-mount part	M2 : Max 2.5 kgf cm		Non Operation
Re-screwed test	15 times under Max. torque		Non Operation
Tapping test	Tapping area : All bezel(Metal cover) side, LCD: Full-screen gray (L32). "Ripple (Pooling)" can not be seen in Active Area Tapping Force: Max 3kgf		Operation

Definitions of failure for judgment shall be as follows:

- (1) Function of the module should be maintained.
- (2) Current consumption should be smaller than the specified value.
- (3) Appearance and display quality should not have distinguished degradation.
- (4) Luminance should be larger than the minimum value specified in optical specification.

Note 1)

(1) The compression condition of front side

(a) Compression point : 12 points (refer to Fig 1-1)

(b) Compression condition: 20kgf, 3 sec, Tool diameter: 16 mm in diameter (refer to Fig 1-3)

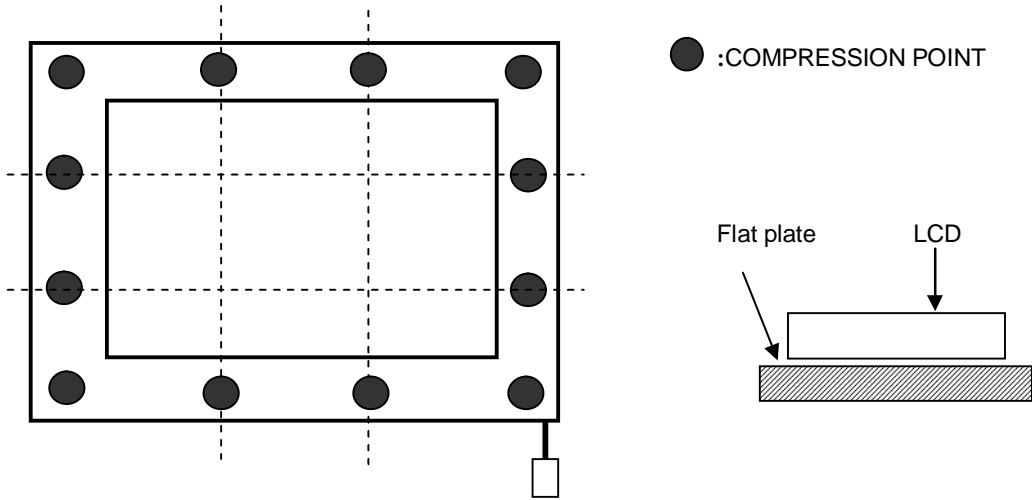

[Fig 1-1]

(2) The compression condition of rear side

(a) Compression point : 21 points (refer to Fig 1-2)

(b) Compression condition : 30kgf, 3 sec, Tool radius: 30 mm in diameter (refer to Fig 1-3)

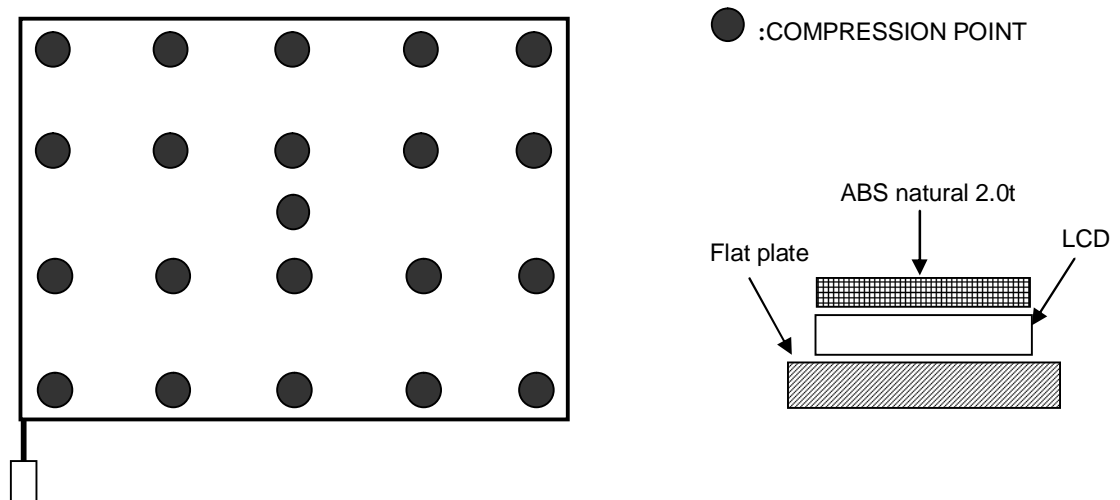

[Fig 1-2]

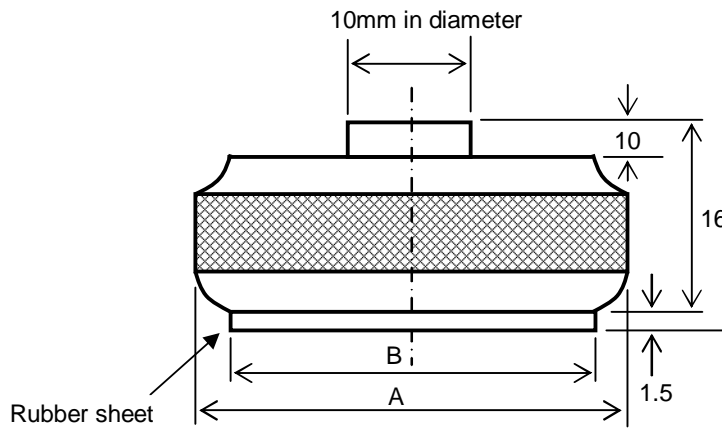

[Fig 1-3]

(3) Dimension of the compression jig

- (a) compression jig for front side
 - A = 16 mm in diameter
 - B = 16 mm in diameter
- (b) compression jig for rear side
 - A = 30 mm in diameter
 - B = 28 mm in diameter

Note 2) LCD fixing condition for z direction.

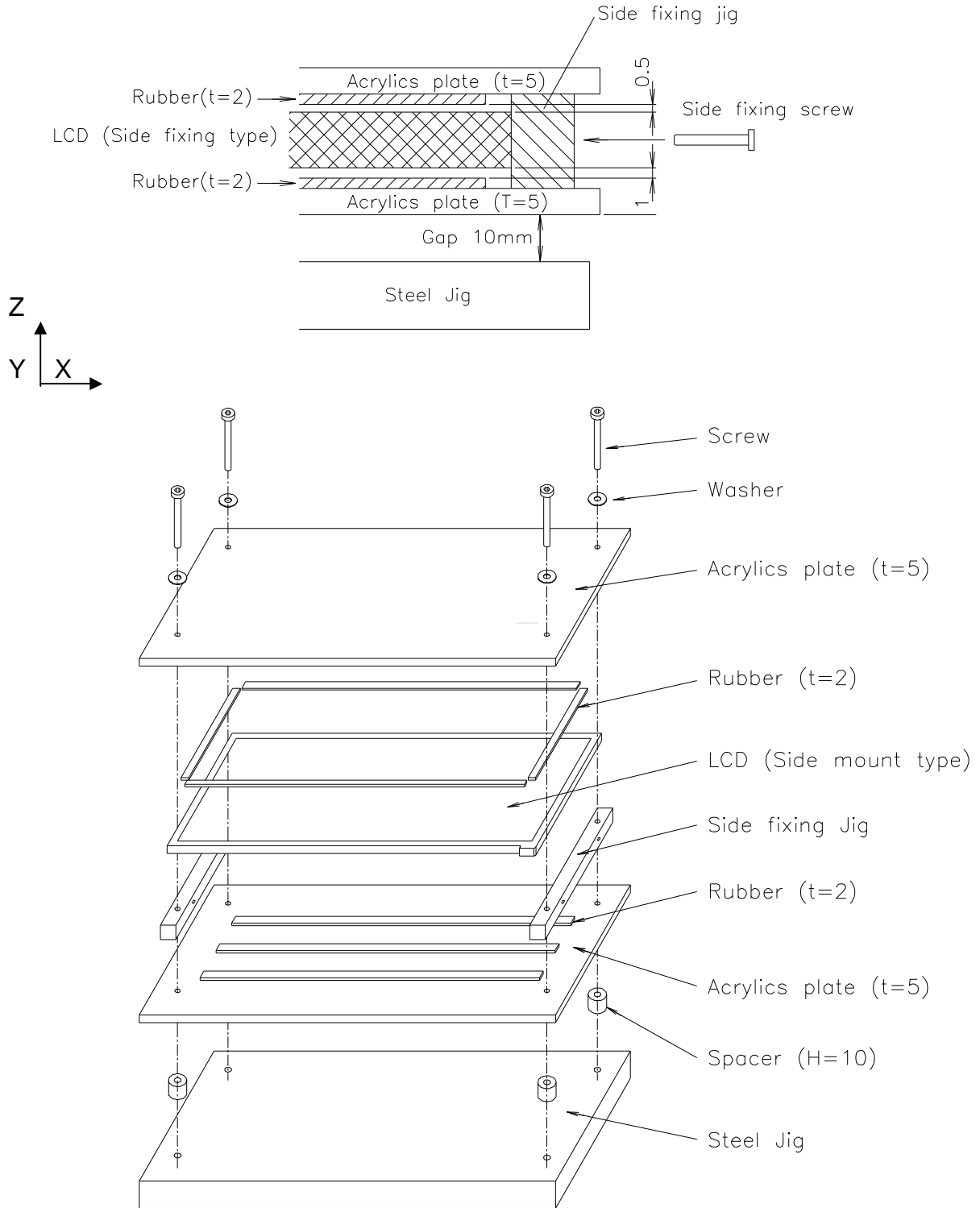

3.4. The Others

(1) Static electricity pressure resistance

Item	Testing conditions	Operation	Non Operation
Contact discharge	150pF, 330 ohm	± 8KV	± 10 kV
Air discharge	150pF, 330 ohm	± 15KV	± 20 KV

(2) Sound noise

There should be no uncomfortable noise.

Being used under whatever surrounds, when power on/off, the panel should not generate uncomfortable noise. And regarding specified values are negotiated if it is needed.

(3) Open / Short

No smoke, no fiery at any open/ short test

(4) MTBF : 50,000 Hr (except for backlight lamp)

4. Optical Characteristics

4.1. Test Conditions

Ambient Temperature : T_a 25±5°C
 Ambient Humidity : H_a 65±20%RH
 Supply Voltage : V_{DD} 3.3V
 Input Signal : According to typical value in "Electrical Characteristics"
 FL Input Current : $I_L = 6.0mA_{RMS}$
 FL Driving Frequency : $f_{LF} = (60±5 \text{ kHz})$
 FL Inverter : FIF1311-06A (PRONTEK Rev1.0)

The measuring method is shown in following 4.2. The items are measured under stable conditions. The optical characteristics should be measured in a dark room (Screen illuminance < 2 lx) or equivalent state with the methods shown in Note (6).

4.2. Optical Specifications

Item	Symbol	Conditions	Min.	Typ.	Max.	Unit	Note	
Contrast Ratio (Center 1 Point)	CR		300	400	-	-	(2), (6)	
Response Time	$T_r + T_f$		-	16	25	ms	(3)	
Average luminance	Y_L	$\theta=0^\circ, \phi=0^\circ$	140	170	-	cd/m ²	* $I_{FL}=6.0mA_{RMS}$ $F_L=60±5kHz$ Gray Scale Level = L63 (White)	
Cross Modulation	D_{SHA}		-	-	2.0	%	(5)	
Luminance Uniformity Chromaticity	Red	R_x	0.554	0.584	0.614	-	(1), (6) PR650 Only for Color Coordinate	
		R_y	0.317	0.347	0.377			
	Green	G_x	0.294	0.324	0.354			
		G_y	0.512	0.542	0.572			
	Blue	B_x	0.128	0.158	0.188			
		B_y	0.115	0.145	0.175			
White	W_x	0.283	0.313	0.343				
	W_y	0.299	0.329	0.359				
Viewing Angle	Hor.	θ_L	CR>=10	$\phi = 180^\circ$	40	45	-	deg. (Color Coordinate of the R,G,B is based on LPL's equipment, and Color Coordinate of the W is based on Toshiba's equipment)
		θ_R		$\phi = 0^\circ$	40	45	-	
	Ver.	θ_{up}	$\phi = 90^\circ$	15	20	-		
		θ_{Low}	$\phi = -90^\circ$	35	40	-		
	Hor.	θ_L	CR>=5	$\phi = 180^\circ$	45	50	-	
		θ_R		$\phi = 0^\circ$	45	50	-	
Ver.	θ_{up}	$\phi = 90^\circ$	20	25	-			
	θ_{Low}	$\phi = -90^\circ$	40	45	-			
13 Points White Variation	δW	$\theta=0^\circ, \phi=0^\circ$	-	1.4	1.6		(7)	
13 Points CR Variation	δC_R	Viewing	-	-	2.0		(7), A	
White Variation	dL	normal angle	-	-	2.0		(8)	

Attach the Lamp current – Luminance characteristics. The range of lamp current is shown in 3.2 (2)

A. Present CR Variation(13Points) Spec is based on PR-880 Equipment and can be changed by the measuring equipment.

Item	Gray level	Conditions	Min.	Typ.	Max.	Unit	Note
Normalized luminance at each gray level	63	$\theta=0^\circ, \phi=0^\circ$ Viewing normal angle	100	100	100	%	(1), (6) (Center 1 Point)
	55		58.0	75.7	89.0		
	47		35.0	53.0	68.5		
	39		20.5	34.9	50.0		
	31		12.0	21.5	33.5		
	23		5.50	12.8	21.0		
	15		1.50	6.30	12.5		
	7		0.40	1.90	6.00		
	0		0.00	0.23	0.50		

At normal viewing direction, during displaying the L0-L63 gray scale bar, luminance intensity inversion can not be seen.

Note 1) Definition of viewing angle θ and ϕ

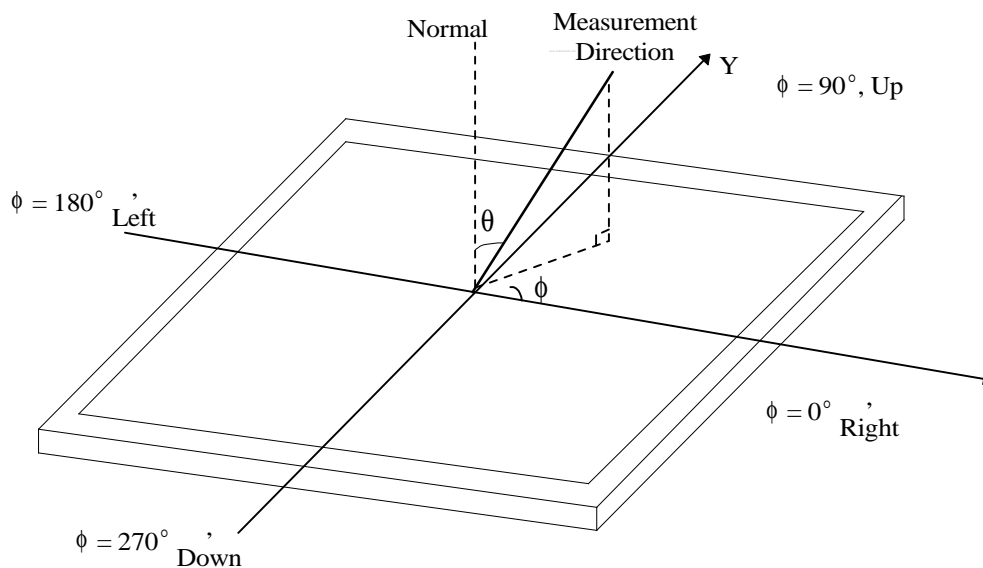

Note 2) LCD fixing condition for z direction.

The contrast ratio can be calculated by the following expression.

$$\text{Contrast Ratio (CR)} = L63 / L0$$

L63 : Luminance on the white raster (gray scale level L63)

L 0 : Luminance on the black raster (gray scale level L0)

Note 3) Definition of response time

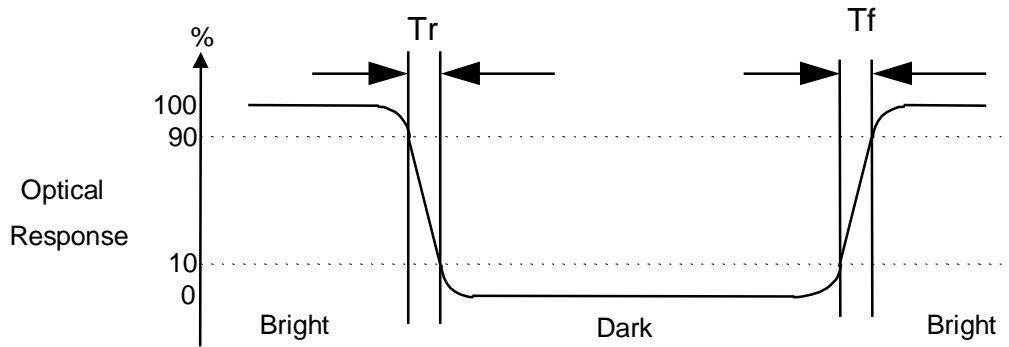

Note 4) Definition of surface luminance of white

Measure the luminance of white at Center point. Surface luminance of white Y_L

Note 5) Definition of Cross Modulation (D_{SHA})

$$D_{SHA} = |Y_B - Y_A| / Y_A \times 100 (\%)$$

Where:

Y_A = Luminance of measured location without darkest gray pattern (cd/m^2)

Y_B = Luminance of measured location with darkest gray pattern (cd/m^2)

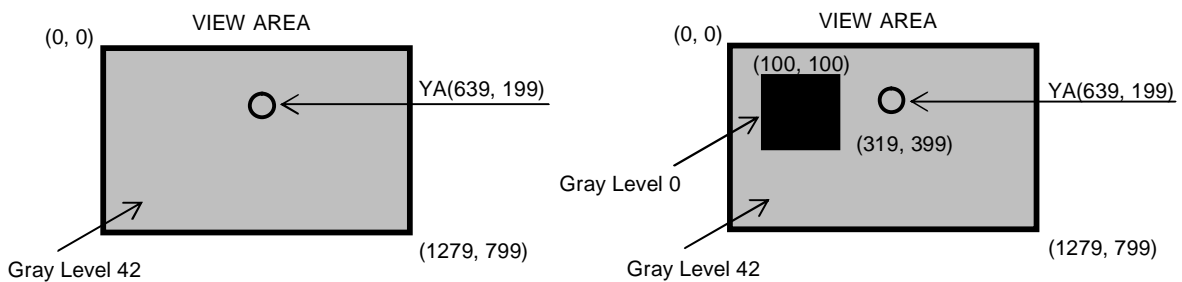

Note 6) Measuring setup

The measurement suppose to be executed after stabilized the panel at given temperature during 30 Min. The measurement shall be executed 30 minutes after lighting at rating. The luminance of white should be typical luminance (Typical Condition IL=6.0mA). In order to stable the luminance, LCD s hall not be got winds.

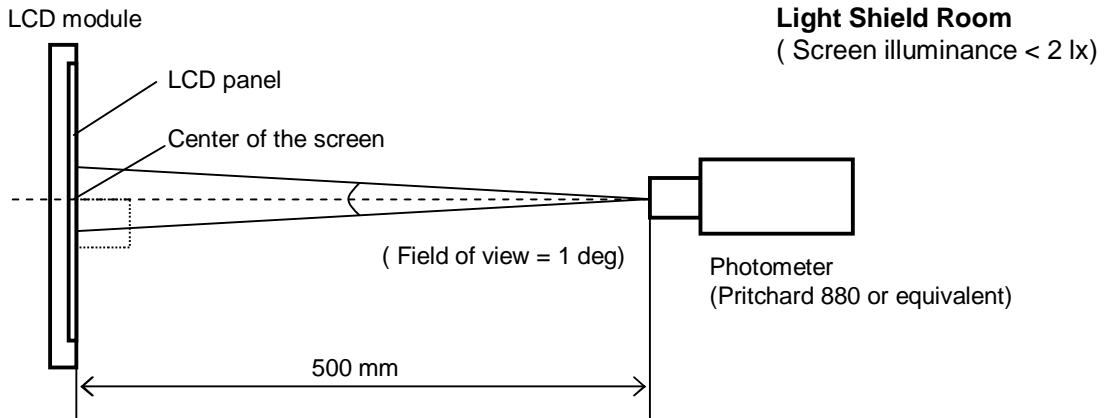

Note 7) Definition of 13 points white variation δW , CR variation δC_R

δW = Maximum luminance of 13 points / Minimum luminance of 13 points

δC_R = Maximum CR 13 points / Minimum CR of 13 points

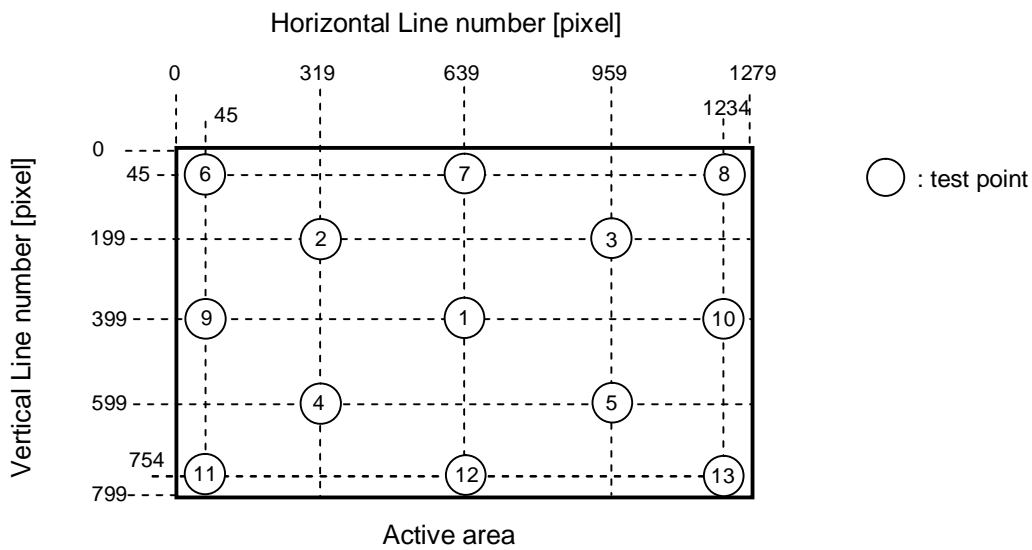

Note 8) Definition of White Variation dL : measure the luminance of white at 13 × 11 points.

$$dL = [| L(x,y) - L(x+l, y+j) | / (L(x,y) \times D(x+l, y+j))] \times 100 \text{ (%/mm)}$$

where $2 \leq x \leq 15, 2 \leq y \leq 11, l = \pm 1, j = \pm 1$

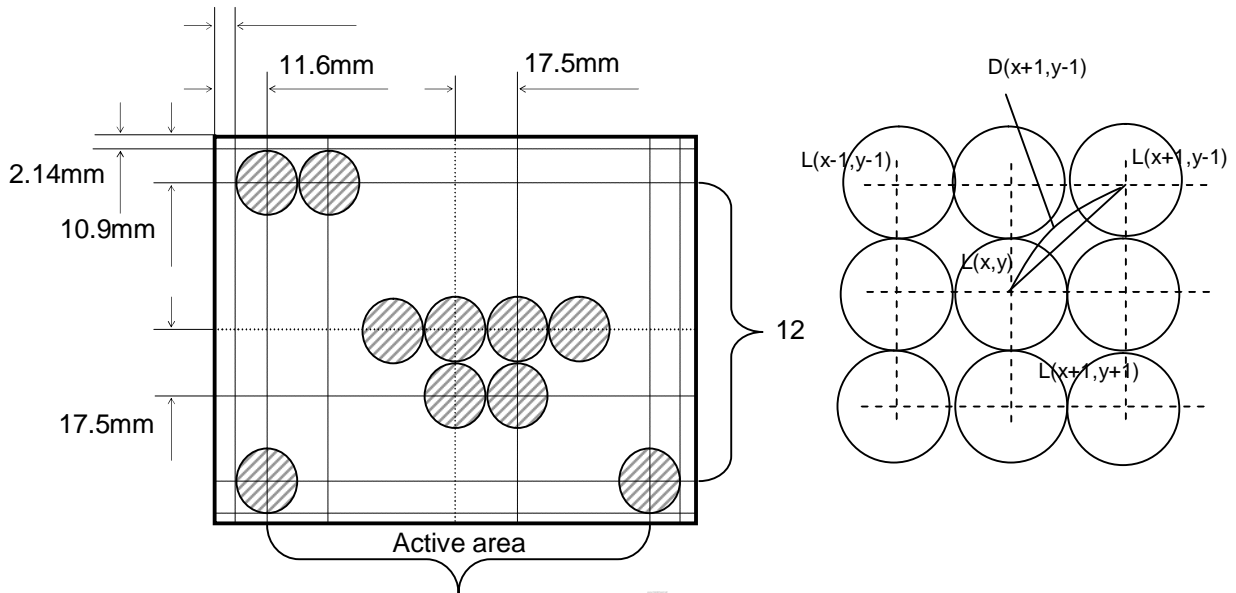

Measuring Spot 16
(Field of View : 2deg. Measuring Distance : 500 mm)

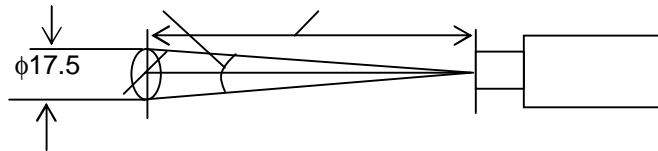

5. Electrical Characteristics

5.1. TFT LCD module

Item	Symbol	Min.	Typ.	Max.	Unit	Note
Power Supply Voltage	V_{DD}	3.0	3.3	3.6	V	
Differential Input Threshold Voltage	High	V_{th}	-	+100	mV	
	Low	V_{tl}	-100	-	mV	
Rush Current	I_{RUSH}	-	-	2.0	A	(5)
Power Supply Current	White(L63)	265	310	355	mA	(3), (4) (a)
	Mosaic	305	360	415		(3), (4) (b)
	Max. Pattern	340	400	460		(3), (4) (c)

Note 1) The module should be always operated within these ranges. The "Typ." shows the recommendable value.

Note 2) Recommended LVDS transmitter : THC63LVDF823A made by THINE or equivalent, Pin to Pin compatible with TI LVDS.

LVDS receiver included in this module is KE5M6U2654 (LCD Controller 1chip)

Note 3) Typical condition as follows. : $f_v = 60\text{Hz}$, $f_{CLK} = 71.0\text{ MHz}$, $V_{DD} = 3.3\text{V}$, DC current.

Note 4) Power dissipation check pattern.

(a) White pattern

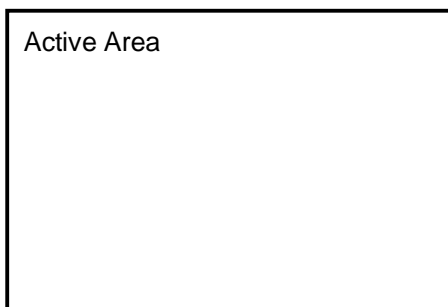

(b) Mosaic pattern

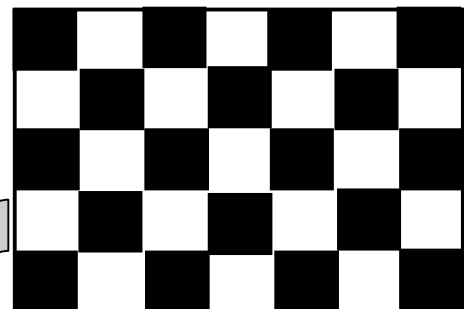

(C) Max. pattern

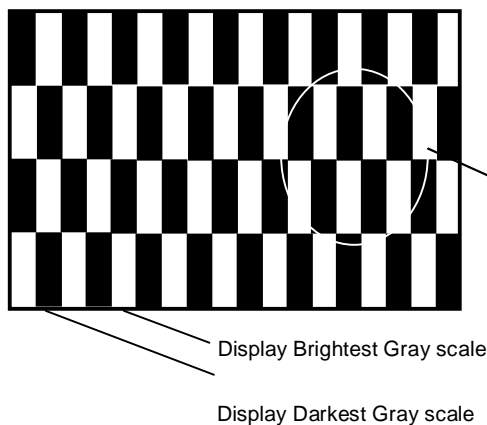

Display Brightest Gray scale
Display Darkest Gray scale

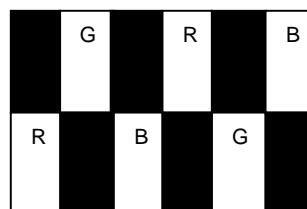
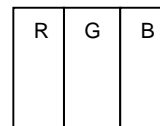

Note 5) Measuring condition of rush current.

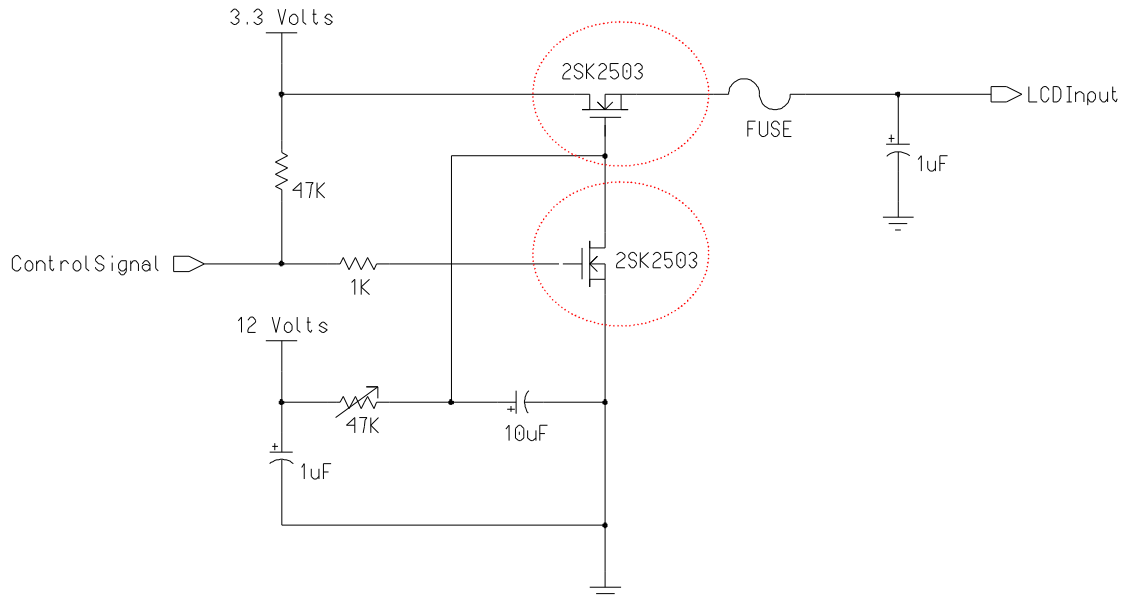

V_{DD} rising time is 470us

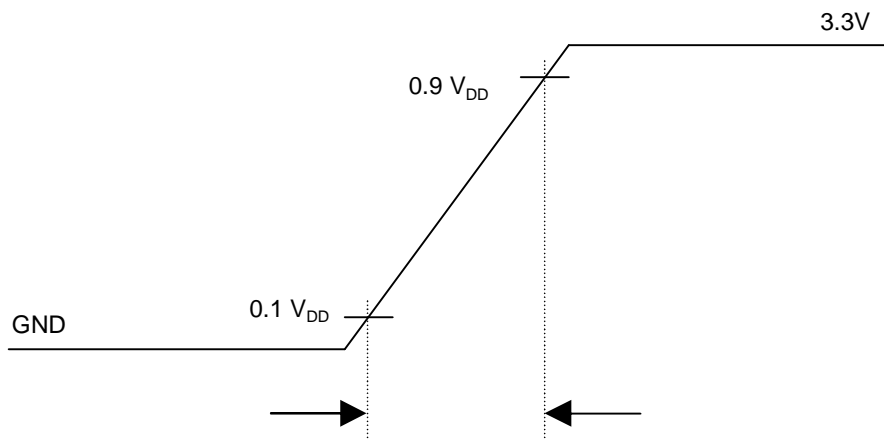

5.2. Backlight Unit

Item	Symbol	Min.	Typ.	Max.	Unit	Note
Lamp Current	I_L	2.0	6.0	6.5	mA_{RMS}	(1)
Lamp Voltage	V_L	655	675	880	V_{RMS}	
Power Consumption	P_L	-	4.1	4.5	W	(2)
Frequency	f_{FL}	50	65	80	kHz	
Operating Life Time	Hr	15,000	-	-	Hour	(3)
Ignition Voltage at 0°C	V_{IV}	-	-	1415	V_{RMS}	(5)
		-	-	-		(4)
Ignition Voltage at 25°C	V_{IV}	-	-	1180	V_{RMS}	(5)
		-	-	-		(4)
Creepage Distance	-	5.0			mm	
Mercury Qt'y of CCFL	-	1.5	-	3.0	mg	

Note 1) Lamp current is measured with a high frequency current as shown below.

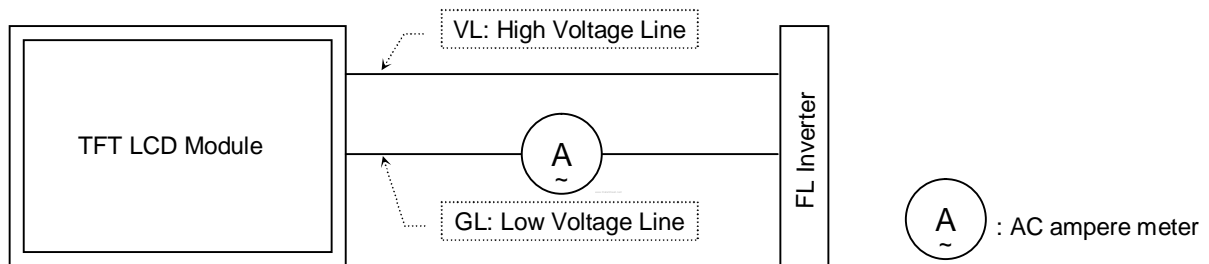

Note 2) Refer to $I_L \times V_L$ to calculate.

Note 3) Life time of Lamp can be defined as the time in which it continues to operate under the condition $T = 25^\circ C \pm 2^\circ C$ and $I_L = 6.0 \text{ mA}$ until one of the following events occurs.

1. When the brightness becomes 50% or lower than it's original.
2. When the Effective ignition length becomes 80% or lower than it's original value.

(Effective ignition length is defined as an area that has less than 70% brightness compared to the brightness in the center point.)

Note 4) The discharge shall be connected uniformly. Slide up method shall be used for voltage application. Above voltage is applied voltage to both ends of the lamp as the starting voltage. (Above value is not out put voltage of inverter.)

Note 5) The lamp shall be lighted stably. Slide up method shall be used for voltage application. Above voltage is applied voltage to both ends of the lamp as the established starting voltage. (Above value is not out put voltage of inverter)

*** Requirements for a system inverter design, which is intended to have a better display performance, a better power efficiency and a more reliable lamp, are following.

It shall help increase the lamp lifetime and reduce leakage current.

a. The asymmetry rate of the inverter waveform should be less than 10%.

b. The distortion rate of the waveform should be within $\sqrt{2} \pm 10\%$.

* Inverter output waveform had better be more similar to ideal sine wave.

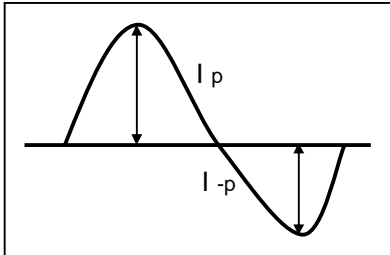

* Asymmetry rate:

$$\frac{|I_p - I_{-p}|}{I_{rms}} * 100\%$$

* Distortion rate

$$I_p \text{ (or } I_{-p}) / I_{rms}$$

Note 6) Detail description of creepage distance

[Section 'A']

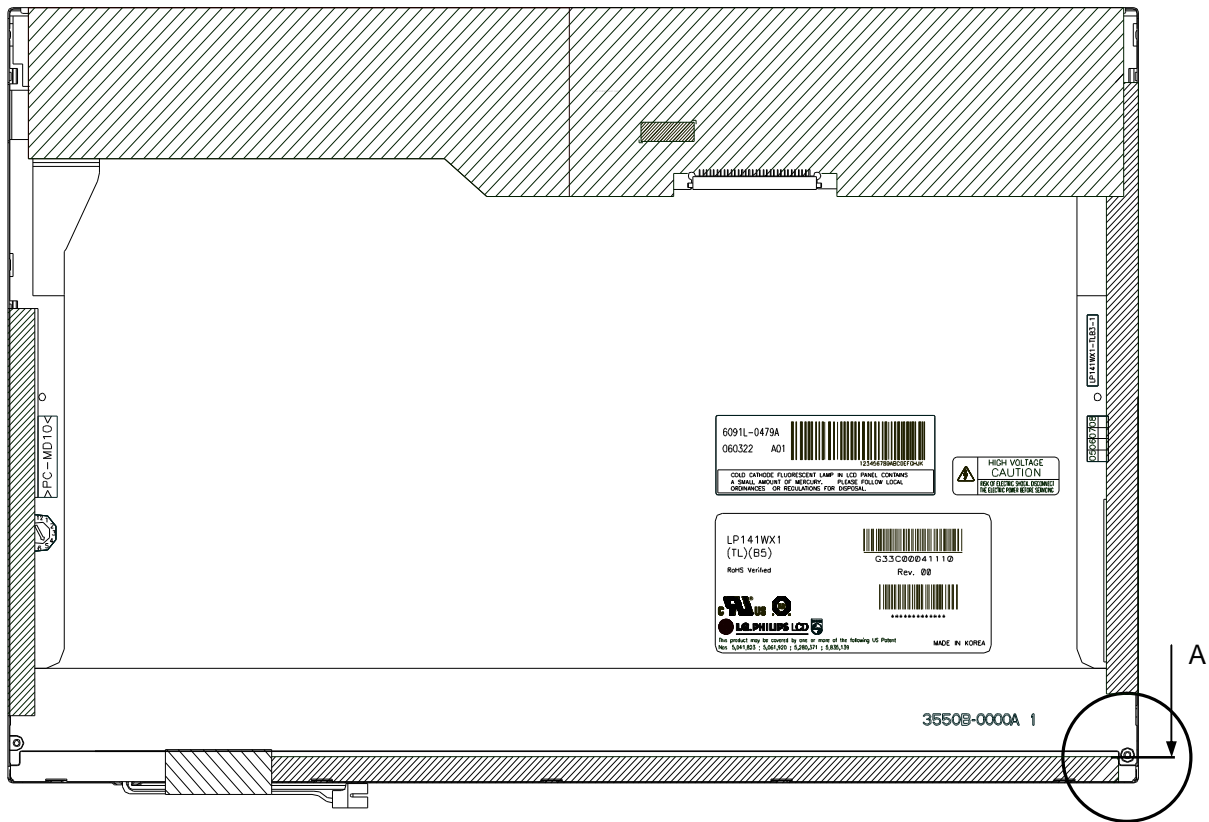
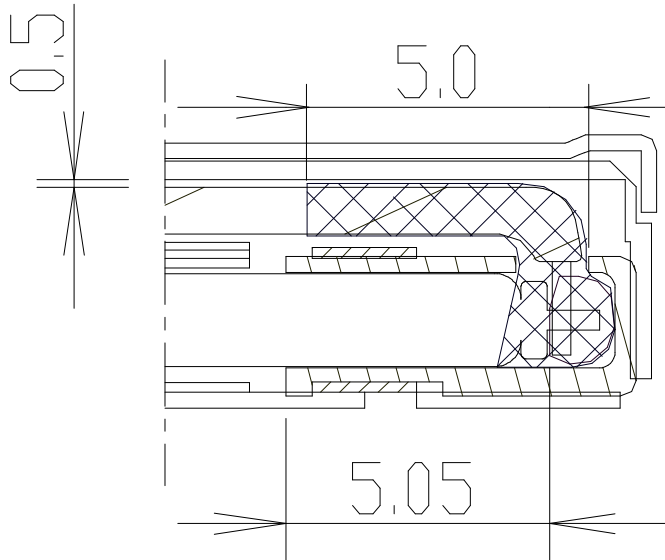

5.3. Regulation

The set (which LCD module is assembled into) should conform to the regulations below.

(1) EMI Regulations.

CISPR

FCC

VCCI

(2) Safety Regulations (Only LCD)

IEC 60950-1

UL 60950-1

(3) Material list concerning

	Item	Silk	Product	Rating	Maker
EMI Filter	ASIC (Data Output)	-	-	-	
	ASIC (Clock Output)	-	-	-	
	Power V _{DD} (3.3V)	-	-	-	
DC/DC	Control IC for Power supply	US1	LM3310	-	National Semiconductor
	Switching Diode	D2,D3,D4	BAV99	SOT-23(3pin)	DIODES
	Schottky Barrier Diode	D1	BAT750	SOT-23(3pin)	DIODES
	Inductor	L1	PLN6012	10 uH ± 20% (Inductance) 0.27Ω ± 20% (DC Resistance) 0.8A Max (Rated Current)	TDK

6. Block Diagram

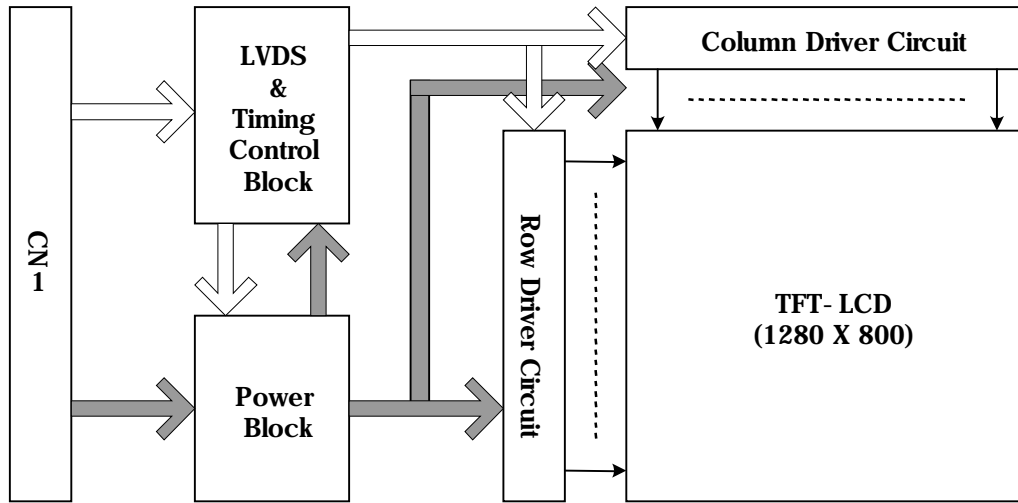

 :Control & Data
  :Power

Lamp wire color (Harison) : White(H) & Black(L)
 Lamp wire color (Sanken) : Pink(H) & Black(L)
 Lamp(Harison) P/No : MBTM18JB222BX313.5MWLEH_C
 Lamp(Sanken) P/No : 1085-0

7. Input Terminal Pin Assignment

7.1. TFT LCD module

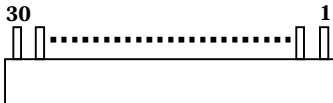
Pin	Symbol	Description	Notes
1	GND	Ground	<p>[LVDS Receiver] Thine, KE5M6U2654</p> <p>[Connector] GT101-30S-HR11 or Compatible</p> <p>[Connector pin arrangement] LCD rear view</p> 
2	VCC	Power Supply, 3.3V Typ.	
3	VCC	Power Supply, 3.3V Typ.	
4	V EEDID	DDC 3.3V power	
5	NC	Reserved for supplier test point	
6	Clk EEDID	DDC Clock	
7	DATA EEDID	DDC Data	
8	R _{IN} 0-	Negative LVDS differential data input	
9	R _{IN} 0+	Positive LVDS differential data input	
10	GND	Ground	
11	R _{IN} 1-	Negative LVDS differential data input	
12	R _{IN} 1+	Positive LVDS differential data input	
13	GND	Ground	
14	R _{IN} 2-	Negative LVDS differential data input	
15	R _{IN} 2+	Positive LVDS differential data input	
16	GND	Ground	
17	CLKIN-	Negative LVDS differential clock input	
18	CLKIN+	Positive LVDS differential clock input	
19	GND	Ground	
20	NC	No Connect	
21	NC	No Connect	
22	GND	Ground	
23	NC	No Connect	
24	NC	No Connect	
25	GND	Ground	
26	NC	No Connect	
27	NC	No Connect	
28	GND	Ground	
29	NC	No Connect	
30	NC	No Connect	

7.2. Backlight Unit

Using Connector : BHTR-02VS (Maker : JST)

(Contact Pin of VL : SBHT-002T-P0.5 (Maker :JST))

(Contact Pin of GL : SBHT-002T-P0.5 (Maker :JST))

Pin	Symbol	Cable Color		Function
		Harison	Sanken	
1	VL	White	Pink	High Voltage
2	GL	Black	Black	Low Voltage

7.3. LVDS Transmitter

LVDS Transmitter : THC63LVDF823A (made by THINE) or compatible.

Pin #	Pin Name	Require Signals	Pin #	Pin Name	Require Signals
1	D4	R4	48	D3	R3
2	Vcc	Vcc	47	D2	R2
3	D5	R5	46	GND	GND
4	D6	G0	45	D1	R1
5	DND	GND	44	D0	R0
6	D7	G1	43	NC	NC
7	D8	G2	42	LVDS GND	LVDS GND
8	Vcc	Vcc	41	Y0M	A0M
9	D9	G3	40	Y0P	A0P
10	D10	G4	39	Y1M	A1M
11	GND	GND	38	Y1P	A1P
12	D11	G5	37	LVDS Vcc	LVDS Vcc
13	D12	B0	36	LVDS GND	LVDS GND
14	NC	NC	35	Y2M	A2M
15	D13	B1	34	Y2P	A2P
16	D14	B2	33	CLKOUTM	CLKM
17	GND	GND	32	CLKOUTP	CLKP
18	D15	B3	31	LVDS GND	LVDS GND
19	D16	B4	30	PLL GND	PLL GND
20	D17	B5	29	PLL Vcc	PLL Vcc
21	Vcc	Vcc	28	PLL GND	PLL GND
22	D18	HSYNC	27	SHDN	SHDN
23	D19	VSYNC	26	CLKIN	Dclk
24	GND	GND	25	D20	DE(Data Enable)

7.4. Timing Diagrams of LVDS Transmission

Switching Characteristic

VCC = 3.0 ~ 3.6V, Ta = -10 ~ +70°C

Transmitter

Symbol	Parameter	Min.	Typ.	Max.	Unit
tTCIT	CLK IN Transition Time	-	-	5	ns
tTCP	CLK IN Period	14.7	T	32.4	ns
tTCH	CLK IN High Time	0.4T	0.5T	0.6T	ns
tTCL	CLK IN Low Time	0.4T	0.5T	0.6T	ns
tTCD	CLK IN to TCLK +/- Delay	-	14.2	-	ns
tTS	TTL Data Setup to CLK IN	3.0	-	-	ns
tTH	TTL Data Hold from CLK IN	1.5	-	-	ns
tLVT	LVDS Transition Time	0.26	0.7	1.5	ns
tTOP1	Output Data Position 0 (T= 15.38ns)	-0.2	0	0.2	ns
tTOP0	Output Data Position 1 (T= 15.38ns)	T/7 - 0.2	T/7	T/7 + 0.2	ns
tTOP2	Output Data Position 2 (T= 15.38ns)	2T/7 - 0.2	2T/7	2T/7 + 0.2	ns
tTOP3	Output Data Position 3 (T= 15.38ns)	3T/7 - 0.2	3T/7	3T/7 + 0.2	ns
tTOP4	Output Data Position 4 (T= 15.38ns)	4T/7 - 0.2	4T/7	4T/7 + 0.2	ns
tTOP5	Output Data Position 5 (T= 15.38ns)	5T/7 - 0.2	5T/7	5T/7 + 0.2	ns
tTOP6	Output Data Position 6 (T= 15.38ns)	6T/7 - 0.2	6T/7	6T/7 + 0.2	ns
tTPLL	Phase Lock Loop Set	-	-	10	ns

AC Timing Diagrams
Transmitter Device

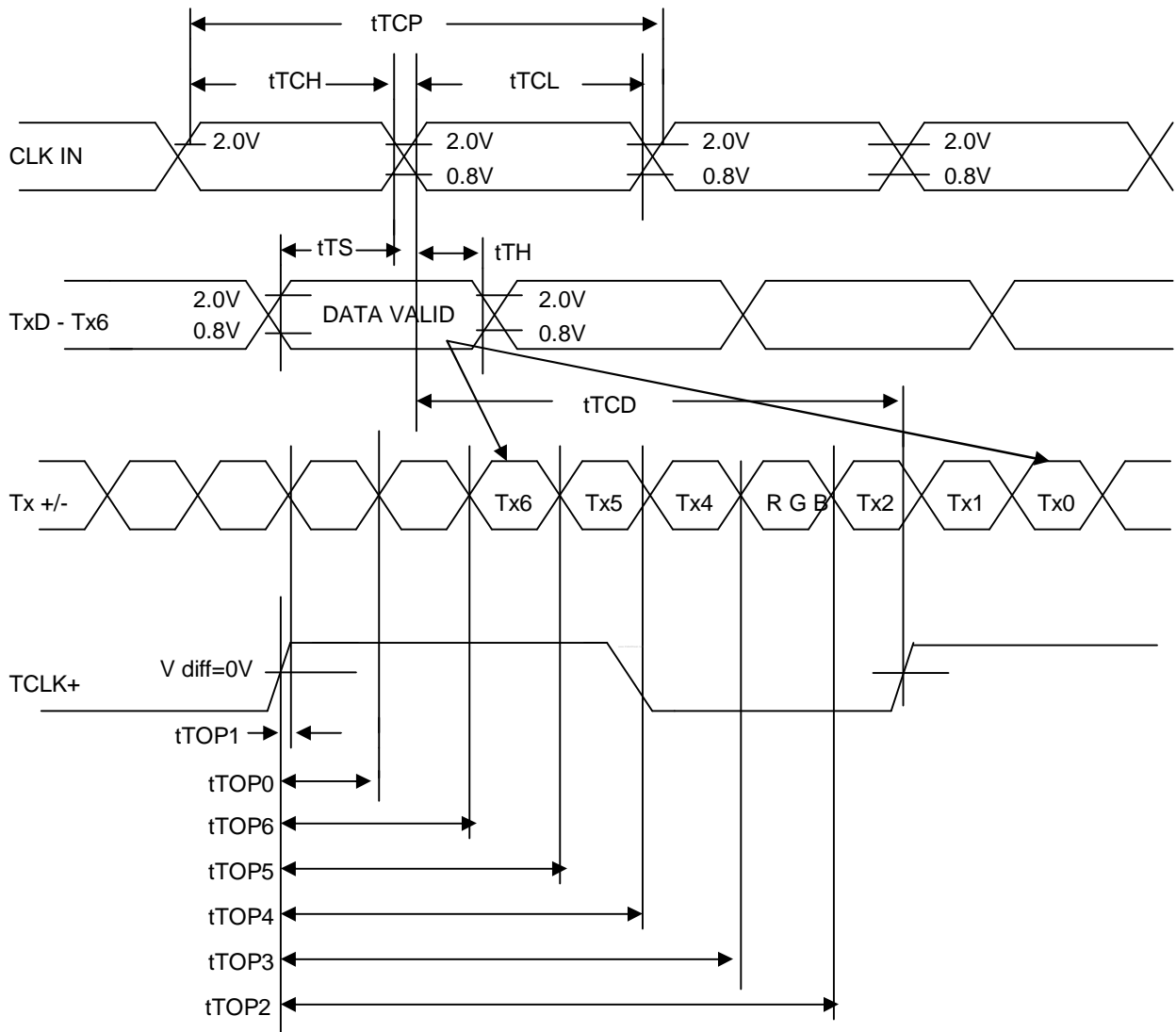

7.5. Input Signal, Basic Display Colors and Gray Scale of each Color

Color		Input Color Data																	
		RED						GREEN						BLUE					
		MSB			LSB			MSB			LSB			MSB			LSB		
		R5	R4	R3	R2	R1	R0	G5	G4	G3	G2	G1	G0	B5	B4	B3	B2	B1	B0
Basic Color	Black	0	0	0	0	0	0	0	0	0	0	0	0	0	0	0	0	0	0
	Red	1	1	1	1	1	1	0	0	0	0	0	0	0	0	0	0	0	0
	Green	0	0	0	0	0	0	1	1	1	1	1	1	0	0	0	0	0	0
	Blue	0	0	0	0	0	0	0	0	0	0	0	0	1	1	1	1	1	1
	Cyan	0	0	0	0	0	0	1	1	1	1	1	1	1	1	1	1	1	1
	Magenta	1	1	1	1	1	1	0	0	0	0	0	0	1	1	1	1	1	1
	Yellow	1	1	1	1	1	1	1	1	1	1	1	1	0	0	0	0	0	0
	White	1	1	1	1	1	1	1	1	1	1	1	1	1	1	1	1	1	1
RED	Black	0	0	0	0	0	0	0	0	0	0	0	0	0	0	0	0	0	0
	RED(Dark)	0	0	0	0	0	1	0	0	0	0	0	0	0	0	0	0	0	0
					
	RED(Bright)	1	1	1	1	1	0	0	0	0	0	0	0	0	0	0	0	0	0
	RED	1	1	1	1	1	1	0	0	0	0	0	0	0	0	0	0	0	0
GREEN	Black	0	0	0	0	0	0	0	0	0	0	0	0	0	0	0	0	0	0
	GREEN(Dark)	0	0	0	0	0	0	0	0	0	0	0	1	0	0	0	0	0	0
					
	GREEN (Bright)	0	0	0	0	0	0	1	1	1	1	1	0	0	0	0	0	0	0
	GREEN	0	0	0	0	0	0	1	1	1	1	1	1	0	0	0	0	0	0
BLUE	Black	0	0	0	0	0	0	0	0	0	0	0	0	0	0	0	0	0	0
	BLUE(Dark)	0	0	0	0	0	0	0	0	0	0	0	0	0	0	0	0	0	1
					
	BLUE(Bright)	0	0	0	0	0	0	0	0	0	0	0	0	1	1	1	1	1	0
	BLUE	0	0	0	0	0	0	0	0	0	0	0	0	1	1	1	1	1	1

Note 1) 0: Low level voltage, 1: High level voltage

8. Interface Timing

8.1. Timing Parameters

This is the signal timing required at the input of the LVDS Transmitter. All of the interface signal timing should be satisfied with the following specifications for its proper operation.

Item	Symbol	Min.	Typ.	Max.	Unit	Note
DCLK	Frequency	fCLK	66.3	71.0	75.0	MHz
Hsync	Period	tHP	1368	1440	1488	tCLK
	Width	tWH	16	32	48	
Vsync	Period	tVP	808	823	840	tHP
	Width	tWV	2	6	8	
Data Enable	Horizontal back porch	tHBP	58	80	98	tCLK
	Horizontal front porch	tHFP	14	48	62	
	Vertical back porch	tVBP	5	14	26	tHP
	Vertical front porch	tVFP	1	3	6	

8.2. Timing Diagrams of LVDS Transmission

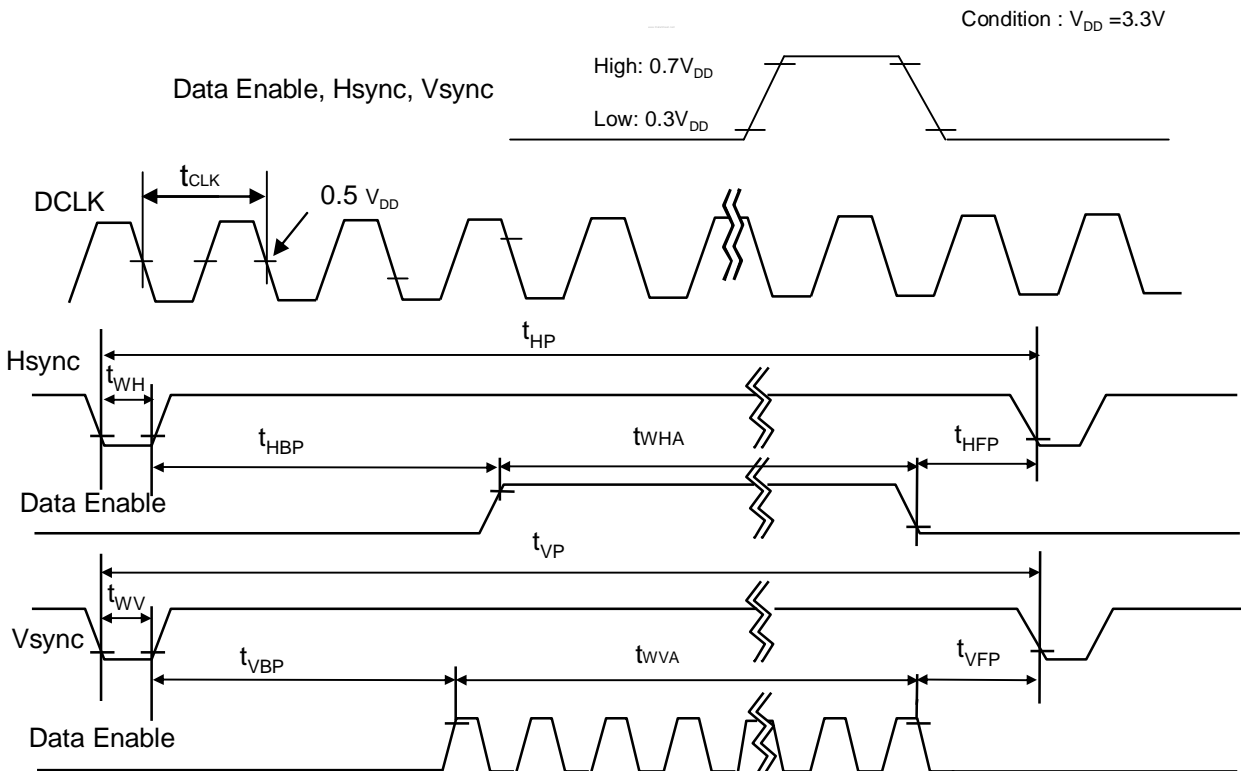

8.3. Power On/Off Sequence

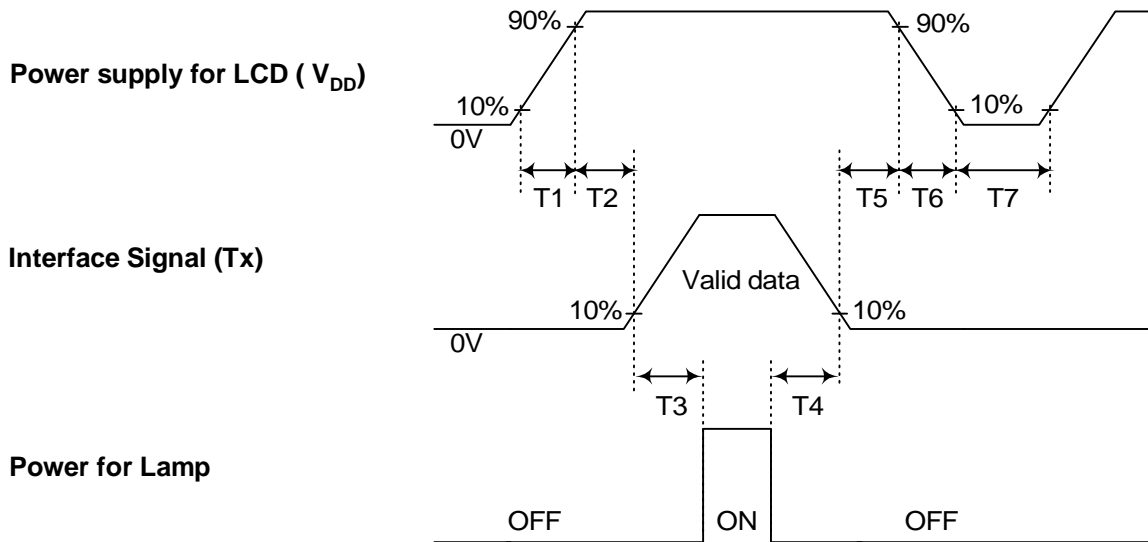

Parameter	Min.	Typ.	Max.	Unit
T_1	0	-	10	(ms)
T_2	0	-	50	(ms)
T_3	200	-	-	(ms)
T_4	200	-	-	(ms)
T_5	0	-	50	(ms)
T_6	0	-	10	(ms)
T_7	200	-	-	(ms)

Note 1) Please avoid floating state of interface signal at invalid period.

Note 2) When the interface signal is invalid, be sure to pull down the power supply for LCD V_{CC} to 0V.

Note 3) Lamp power must be turn on after power supply for LCD and interface signal are valid.

9. Cosmetic Specification

9.1. Sampling

A.Q.L (Acceptable Quality Level): MIL-STD, 105E Level II,
Major: 0.65 , Minor: 1.5

9.2. Conditions of Inspections

- (1) Ambient Temperature : 25±5°C
- (2) Ambient Humidity : 65±20%RH
- (3) Illumination : 200 – 500 Lux (nominal 350 Lux) under the fluorescent lamp
- (4) Viewing Distance: Approximately 30cm by the eyes of the inspector from the module
- (5) Viewing angle : The surface of the module and the inspector's line shall be at 90 ± 45 degrees.
- (6) Display pattern: Pure Red, Green, Blue, Black, White, Gray level 0 - 63

9.3. Defect modes

Defect Mode	Description
Dark / Bright spots	Points on the display which appear dark / bright and remain unchanged in size
Dark / Bright lines	Lines on the display which appear dark / bright and remain unchanged in size
Polarizer scratch	When the unit is lit a light , line is seen across a darker background; line does not vary in size
Polarizer dent	When the unit is lit a light, light (white) spots appear against a darker background, and do not vary in size
Bright / dark dot	A sub-pixel (R,G,B dot) stuck off / on
Rubbing line	Diagonal lines that appear gray with the display patterns dark and vary in size
Dim line	When the unit lights, lines in the minor (Vertical) or major (Horizontal) axis appear dim
Cross line	When the unit lights, lines in the both minor and major axis do not appear
Interference	Interference can not be seen with any bright plane display at any viewing angle
Flicker	When displaying sub-pixel checker (gray level and darkest gray), flicker can not be seen
Ripple (Pooling)	Tapping Test, Tapping area : All bezel(Metal cover) side, LCD: Full-screen gray (L32) "Ripple (Pooling)" can not be seen in Active Area

9.4. Mechanical Inspection

- (1) Light leakage: No light leakage between metal chassis (bezel) and glass
- (2) No sharp edge
- (3) The mounting holes: No Changed (Side fixed type)
- (4) PCB Appearance: No pattern peeling snapping / No electrically short
If there are repair portions, the repair portions on PCB is covered by epoxy resin
- (5) Soldering: No cold solder joint, lead move when pulled
- (6) Bezel, Frame, Connectors: No distinct stain, rust or scratch, no pin bending

9.5. Visual Inspection

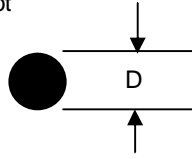
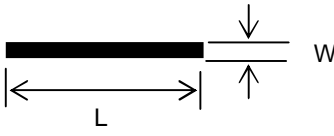
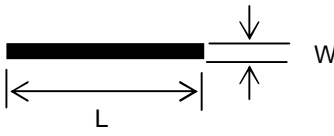
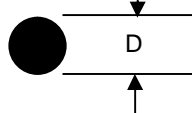
Defect type	Count (mm)	Reject (mm)
Dark / bright spot 	$0.2 < D \leq 0.5$ $N \leq 3$	$D > 0.5$
Dark / Bright lines 	$0.05 < W \leq 0.07$ $0.3 < L \leq 3.0$ $N \leq 3$	$W > 0.07$ $L > 3.0$
Polarizer scratch 	$0.01 < W \leq 0.1$ $0.3 < L \leq 0.5$ $N \leq 3$	$W > 0.1$ $L > 0.5$
Polarizer dent / bubble 	$0.2 \leq D \leq 0.5$ $N \leq 3$	$D > 0.5$
Maximum allowable number of defects	$N \leq 7$	$N > 7$
Rubbing defect	Not allowed	
Dim line	Not allowed	

[D : diameter, W : width, L : length, N : count]

Note 1) Inspection area should be within bezel opening.

Note 2) Dusts which are bigger not less than 0.10mm ($0.1 \leq W$) shall be judged by "Average Diameter".

Note 3) Scratches which are bigger not less than 0.05mm ($0.05 \leq W$) shall be judged by "Average Diameter".

Average Diameter $D = (a+b)/2$ (mm)

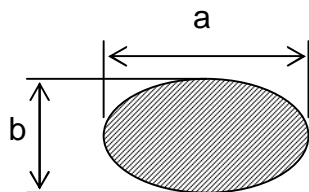

9.6. Electrical Inspection

(1) Dot defect

Defect type		Count	Reject
Bright dots	Random	$N \leq 2$ (Green ≤ 1)	$N > 3$ (Green > 2)
	Two adjacent	Not allowed	
	Three or more adjacent	Not allowed	
Dark dots	Random	$N \leq 3$	$N > 4$
	Two adjacent	$N \leq 1$	$N > 2$
	Three or more adjacent	Not allowed	
Maximum allowable number of dot defect		$N \leq 6$	$N > 7$
Maximum distance between defects	Bright - to - bright dot	$L \leq 15\text{mm}$	$L > 16\text{mm}$
	Dark - to - dark dot	$L \leq 10\text{mm}$	$L > 11\text{mm}$

- 1) Inspection patterns for dot defect are Pure Red, Green, Blue, Black, and White.
- 2) Adjacent two dots will be counted as two dots.
- 3) The distribution of dot defects should be below. Average value of dot defect s should be less than 1.

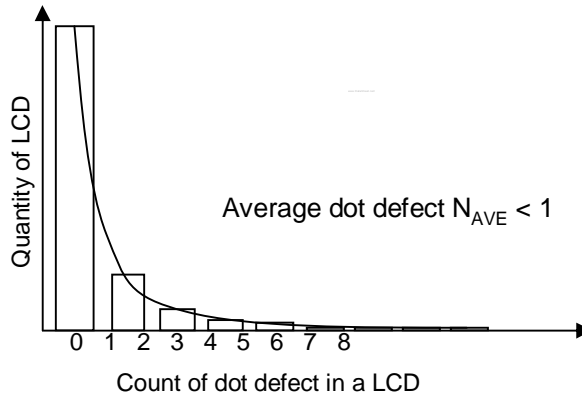

Required distribution of dot defect

4) The definition of 2 adjacent dots.

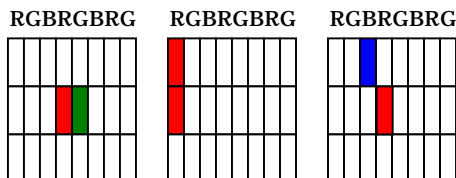

(2) Light leakage

Light leakage can not be seen between metal chassis (bezel) and glass when displaying black plane.

(3) Image sticking

Image sticking pattern shall not be to persist longer than 1second after displaying following pattern 8 hours in the room temperature condition.

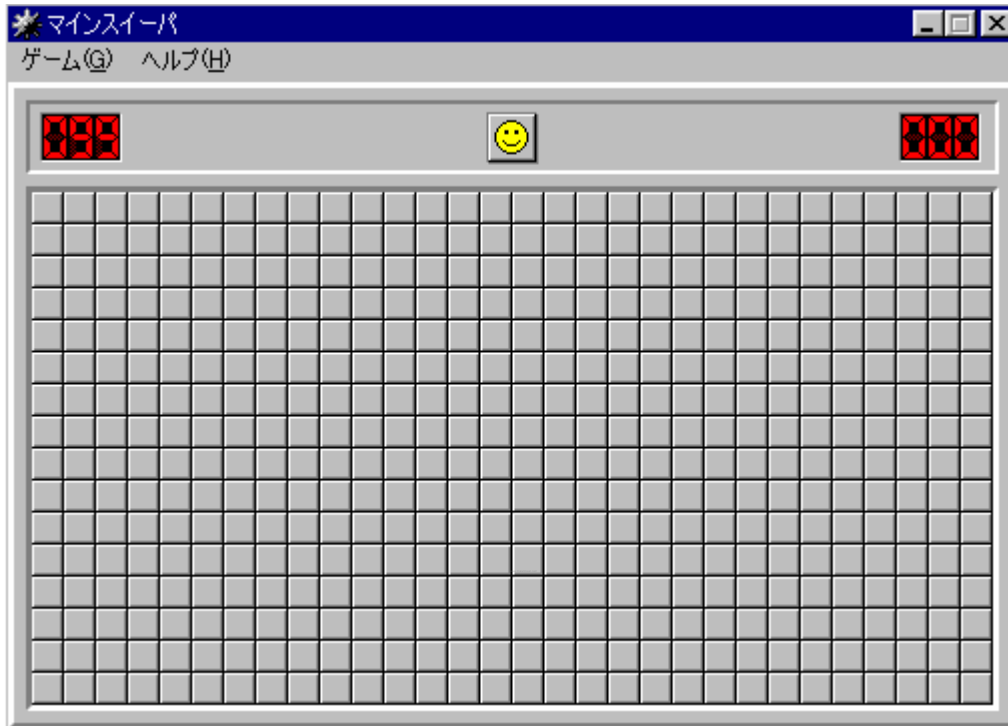

(4) Glue/stain/dirt

Glue, non-removable stain and dirt which are visible in the inspection area are not acceptable.

10. Packing

10.1. Carton

(1) Packing Form

Corrugated cardboard box and EPS

(2) Packing Method

Packing Material : EPS

Packing Weight: : 1,1kg

Packing Weight, 20 PCS modules included : 9.8kg

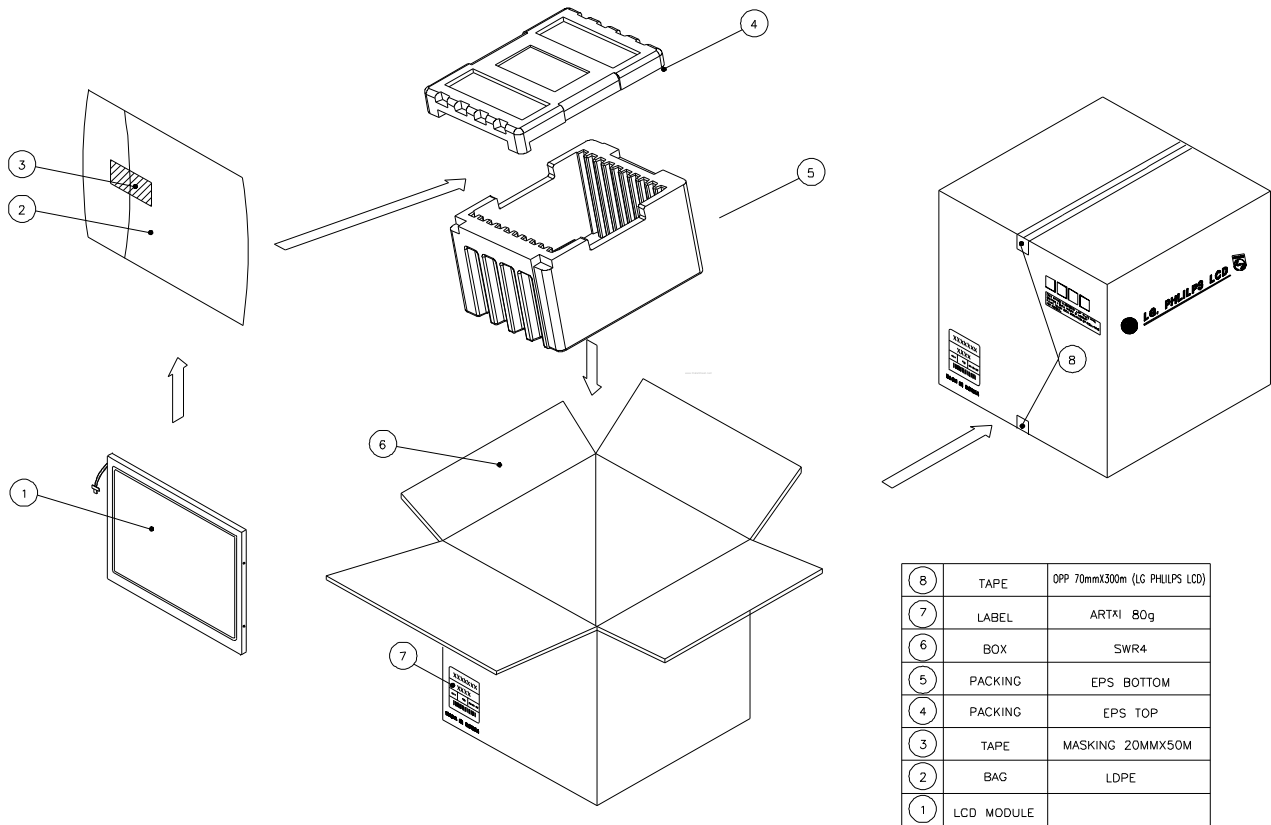

Item	Conditions
Packing Vibration	Frequency Range : 5 - 50 Hz, Degree of acceleration 1G(9.8m/s ²). Sweep rate 3 minutes Top & Bottom 60 minutes, Right & Left 15 minutes, Back & Forth 15 minutes
Packing Drop Test	1 Angle, 3 Edge, 6 Face, 76 cm

(4) Package Label

Package label should be at least shown the following information.

- a) TOSHIBA code name(G33C00041110) which will be numbered by Toshiba
- b) Revision number which be numbered by LCD maker
- c) Quantity
- d) LCD maker
- e) Model number which be numbered by LCD maker
- f) Production Year / Month

(5) Location of Package label : 2 points (Side)

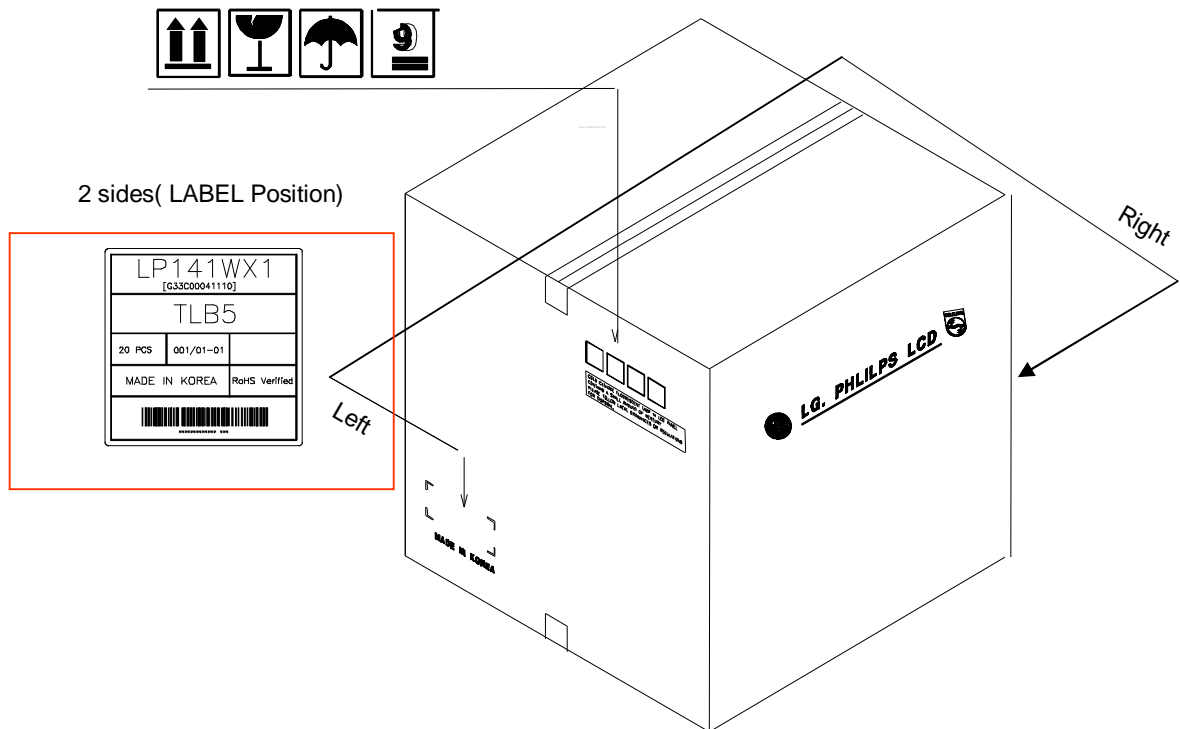

11. Labels and Lamp Ass'y Exchange

11.1. LCD code Label on LCD

LCD code label should be at least shown the following information.

- (1) TOSHIBA code name (G33C00041110) which will be numbered by Toshiba & Bar code
(Bar code : CODE-39 High-density)
- (2) LGPL Serial number CODE (numbered by LCD maker , less than equal 13 digits)

A	B	C	D	E	F	G	H	I	J	K	L	M
---	---	---	---	---	---	---	---	---	---	---	---	---

A,B,C : SIZE(INCH)
E : MONTH

D : YEAR
F ~ M : SERIAL NO.

Note

1. YEAR

Year	2001	2002	2003	2004	2005	2006	2007	2008	2009	2010
Mark	1	2	3	4	5	6	7	8	9	0

2. MONTH

Month	Jan	Feb	Mar	Apr	May	Jun	Jul	Aug	Sep	Oct	Nov	Dec
Mark	1	2	3	4	5	6	7	8	9	A	B	C

Serial NO. Is printed on the label. The label is attached to the backside of the LCD module.
This is subject to change without prior notice.

Example >

LABEL : 78mm X 37mm

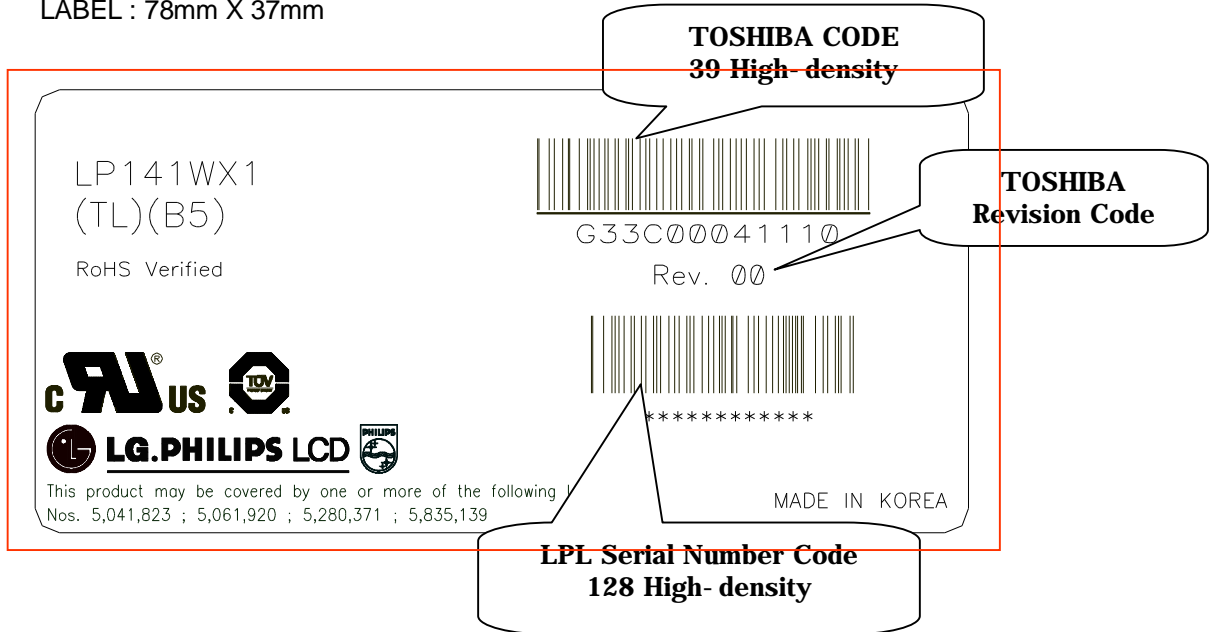

The revision code is inserted in the label by Toshiba request. If the contents of the specification need to be change under mass-production, the code can be revised after Toshiba's approval. Although there is not items in the contents of the specification, Toshiba can requests LPL to change the revision code.

11.2. Caution Texture on LCD

[Disposal of CCFL]

FLUORESCENT LAMP IN LCD PANEL CONTAINS A SMALL AMOUNT OF MERCURY. PLEASE FOLLOW LOCAL ORDINANCES OR REGULATIONS FOR DISPOSAL.

[High Voltage]

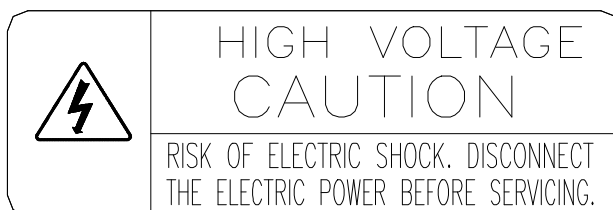

11.3. Label Locations on LCD

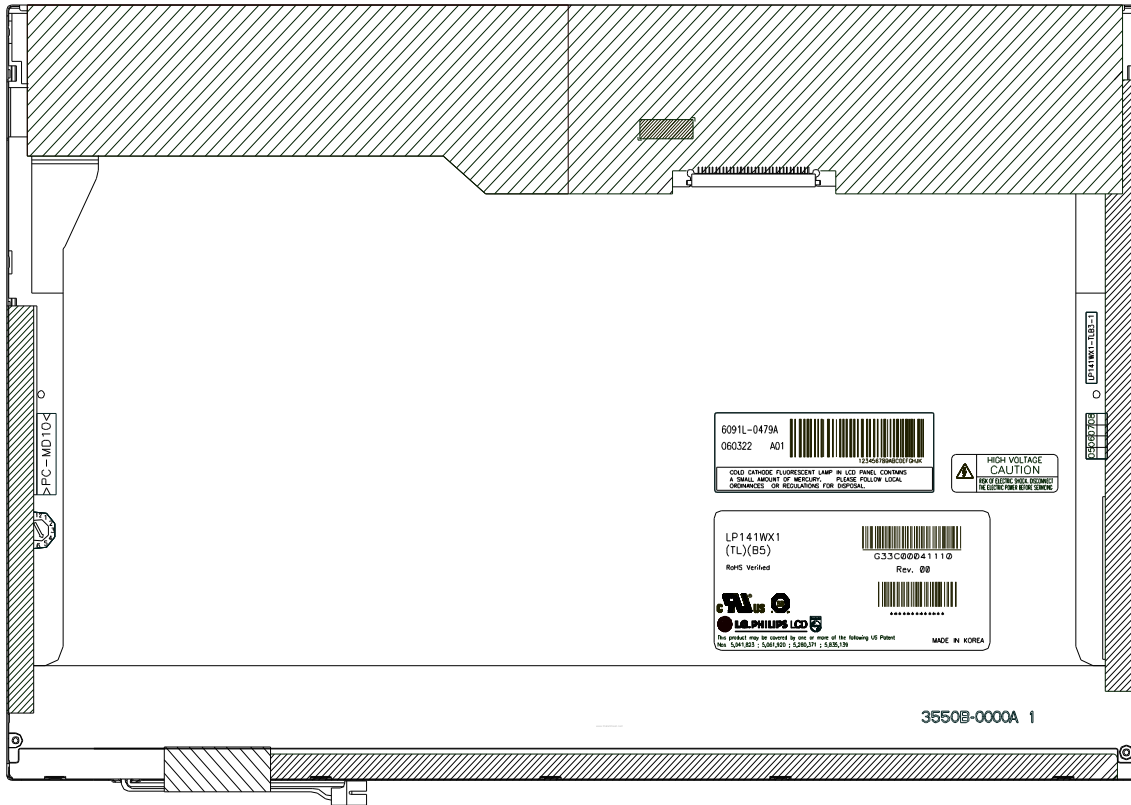

11.4. Others

(1) Backlight repair parts kit : (G33C00041110001)

No.	Part	Product Code	Maker	Qt'y	Note
1	Cover Ass'y Bottom(L)	3550B-0214A	Hee Sung	1	
2	Cover Shield(S)	3550S-0352B	Jae Hyun	1	
3	Cover Shield(G)	3550S-0412A	Geo Rim	1	
4	Tape Adhesive	7250L-0050S	Jae Hyun	1	
5	Tape Adhesive	7250L-0080B	Jae Hyun	1	
6	Tape Adhesive	7250L-0077A	Jae Hyun	1	
7	Tape Adhesive	7250L-0076P	Hee Sung	2	
8	Tape Adhesive	7250L-0076N	Hee Sung	2	

(2) Package specification of Backlight repair parts kit
 a) Individual packing

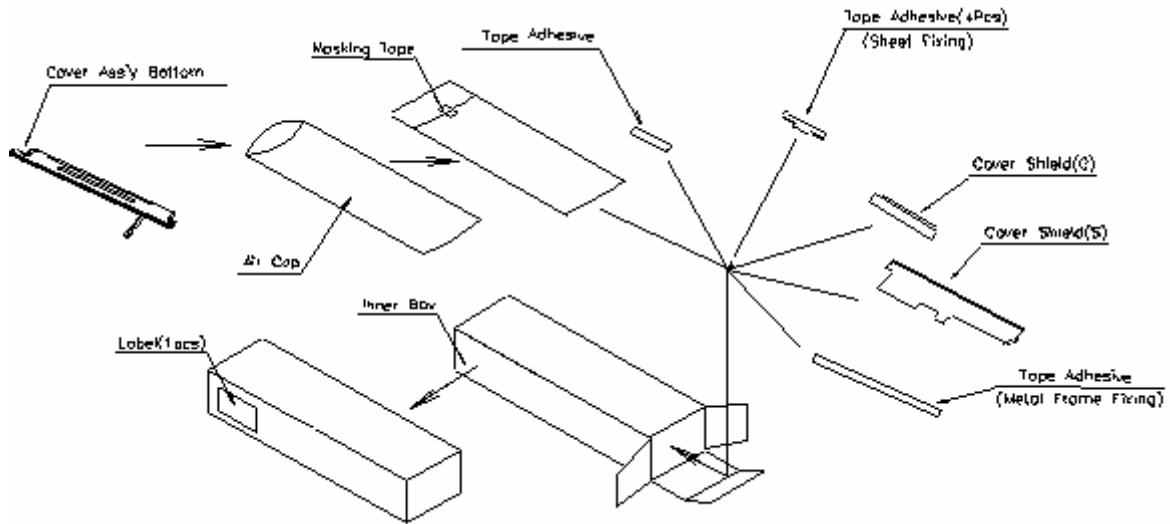

b) Master carton Packing method

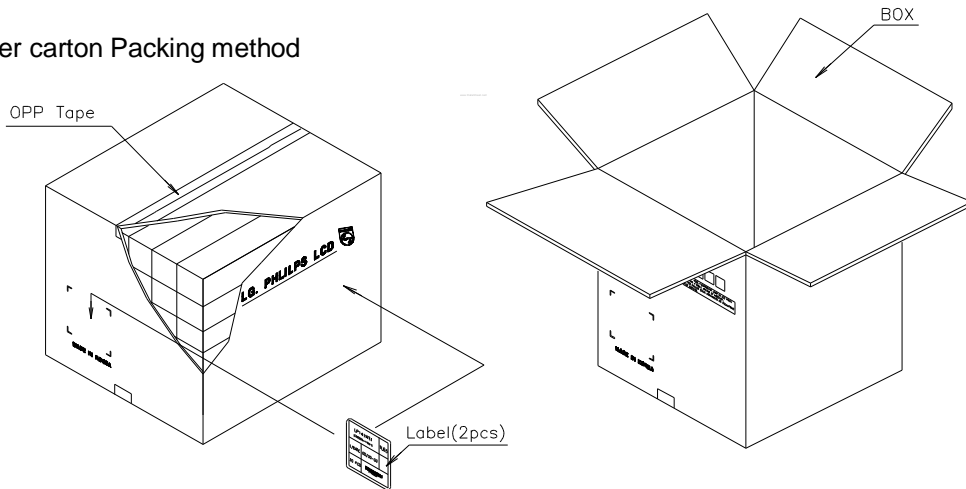

c) Label

[6(V) x 5(H) = 30 Boxes Inner]



11.5. Instruction of changing the Lamp parts - Lamp Ass'y Exchange process

11.5.1. Disassembly of outside tape / Cover shield

- (1) ① Disassembly of Tape Adhesive used for Top case fixing
 Caution: Pressure or stress should not be given on Top case during this process
- (2) ② Disassembly of Cover shield(G)
 Caution: Pressure or stress should not be given on Gate COF.
- (3) ③ Disassembly of Cover shield(S)
 Caution: Pressure or stress should not be given on Source PCB.
 Usage of gloves with anti-electric discharge coating is recommended.
 To eliminate possible damage on circuits occurred by ESD.

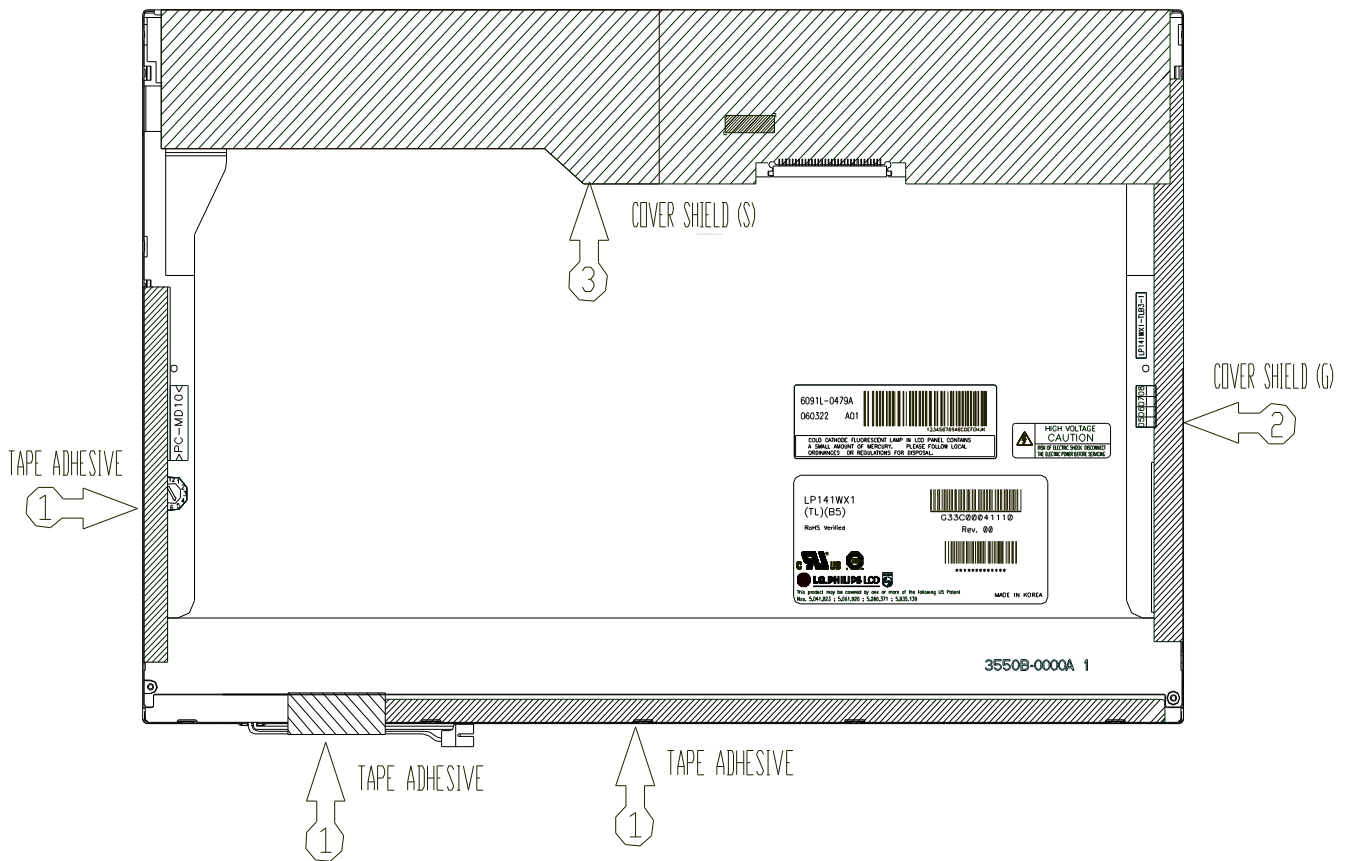

11.5.2. Disassembly of Top Case

(1) ① Disassembly of Top Case

Caution: Pressure or stress should not be given on PCB and COF.

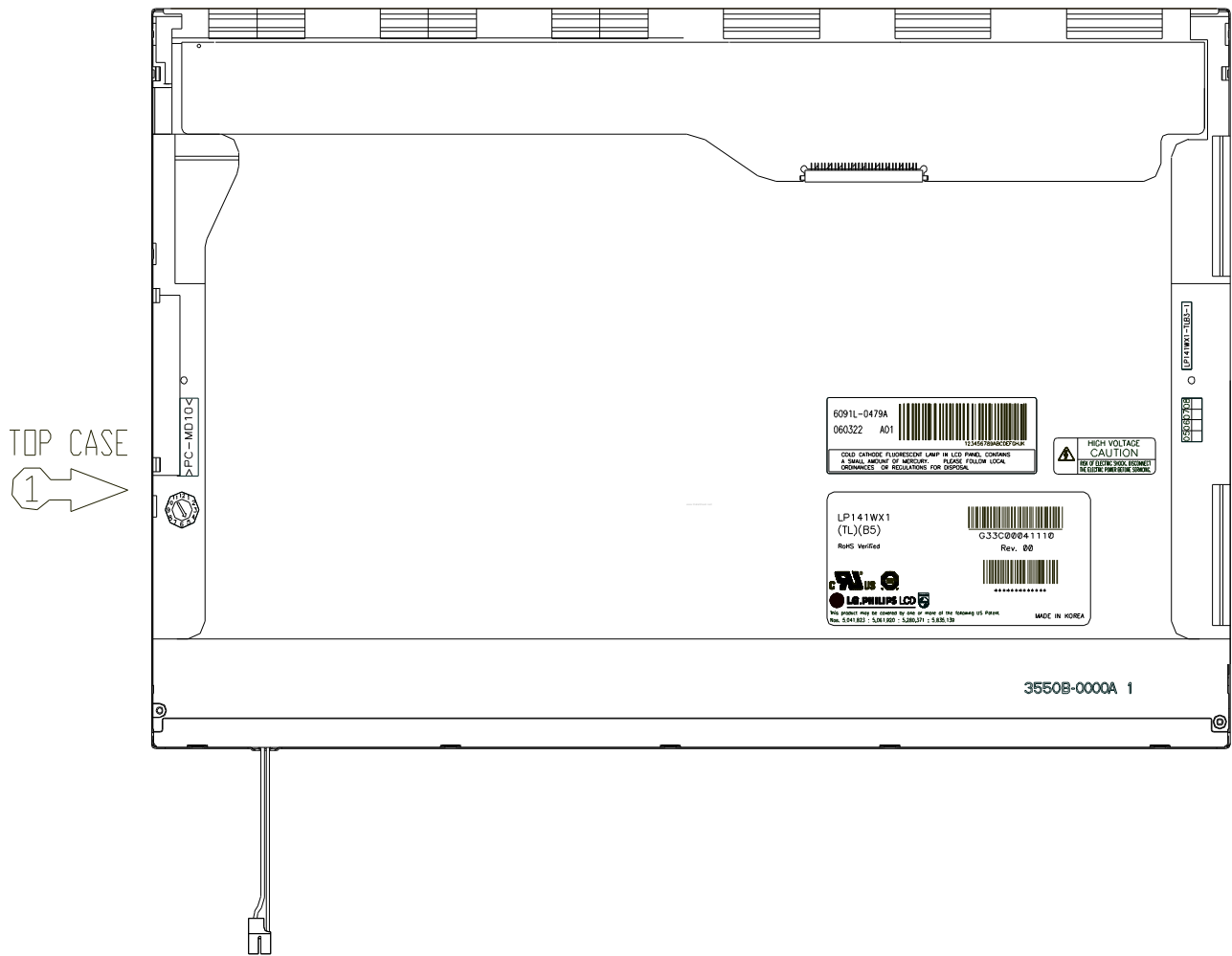

11.5.3. Disassembly of Source PCB

- (1) ① Disassembly of Source PCB.

Caution: Pressure or stress should not be given on PCB and COF

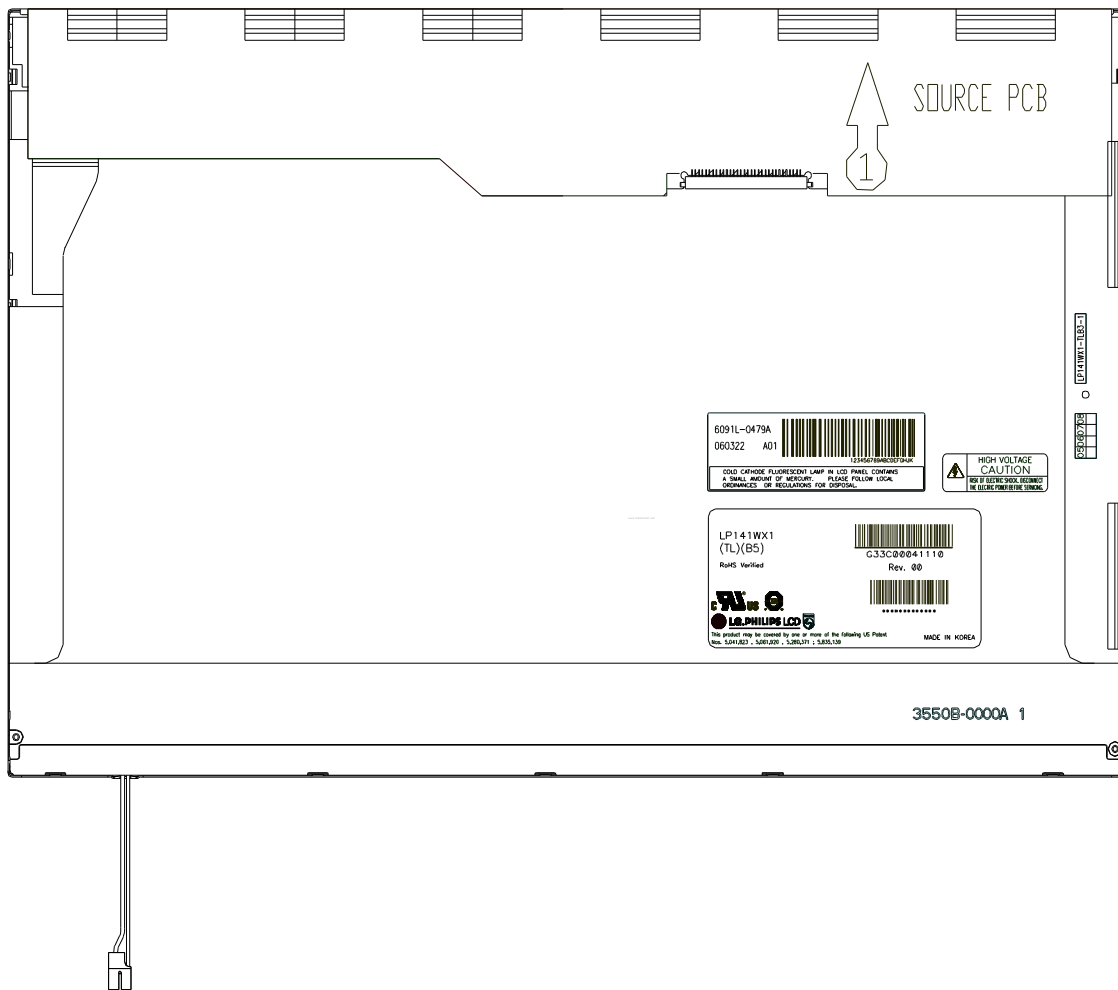

11.5.4. Disassembly of Board Ass'y, Tape Adhesive, Sheets, Light guide,Cover Ass'y Bottom(L)

- (1) ① Disassembly of Board Ass'y.

Caution: This process should be made in Clean room with no scratch nor particle on Polarizer and B/L Ass'y.

- (2) ② Disassembly of Tape Adhesive used for Sheets fixing (4Point).

- (3) ③ Disassembly of Sheets, Light guide.

Caution: No penetration of foreign body is indispensable with no scratch on the surface of each Sheets.

- (4) ④ Disassembly of Screw(2Point) and Cover Ass'y Bottom(L)

Caution: Maximum value of torque with Screw should be below 2.5kgf cm.

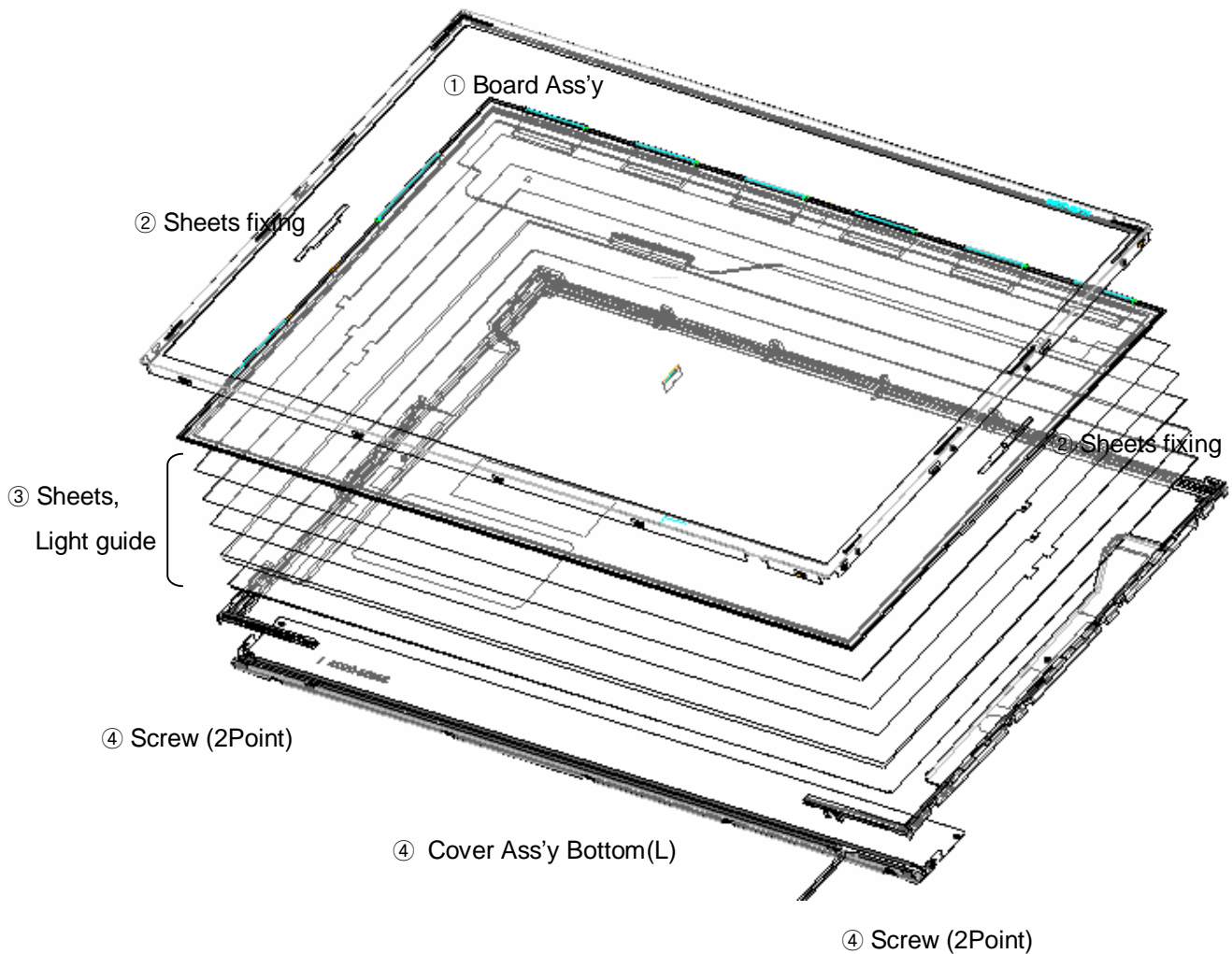

11.5.5. Assembly of Cover Ass'y Bottom(L), Sheets, Light guide, Tape Adhesive and Board Ass'y.

- (1) ① Detach a release paper from Double Tape at the Cover Ass'y Bottom(L)
- (2) ② Assembly of Cover Ass'y Bottom(L) and Screw(2Point).
Caution: Maximum value of torque with Screw should be below 2.5kgf.cm
- (3) ③ Assembly of Light Guide and Sheets
Caution: No penetration of foreign body is indispensable with no scratch on the surface of each Sheet and Light guide.
- (4) ④ Assembly of Tape adhesive used for Sheets fixing(4Point)
- (5) ⑤ Assembly of Board Ass'y.
Caution: Pressure or stress should not be given on PCB and COF.

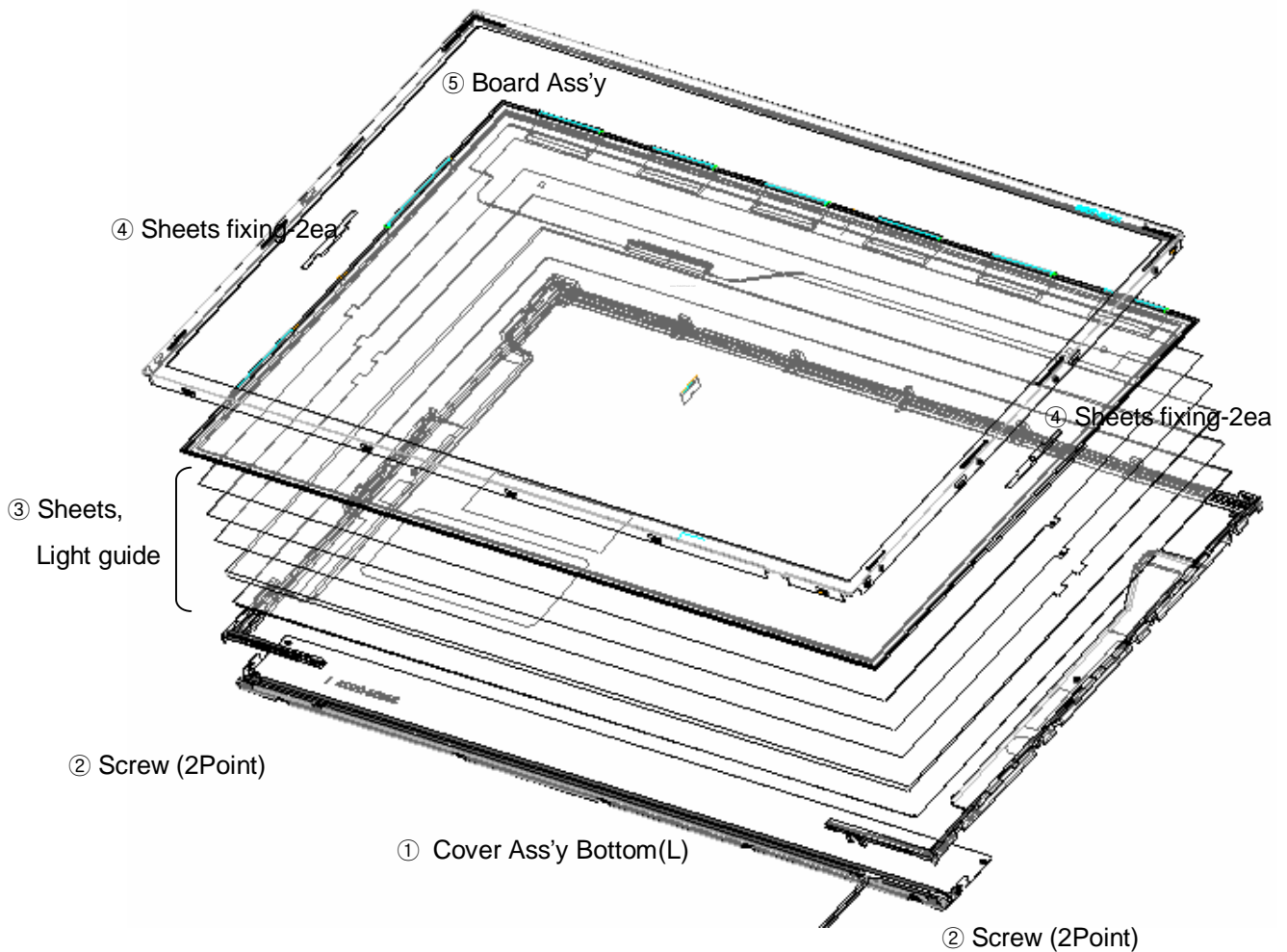

11.5.6. Assembly of Source PCB

- (1) ① Assembly of Source PCB.

Caution: Stress should not be given on COF

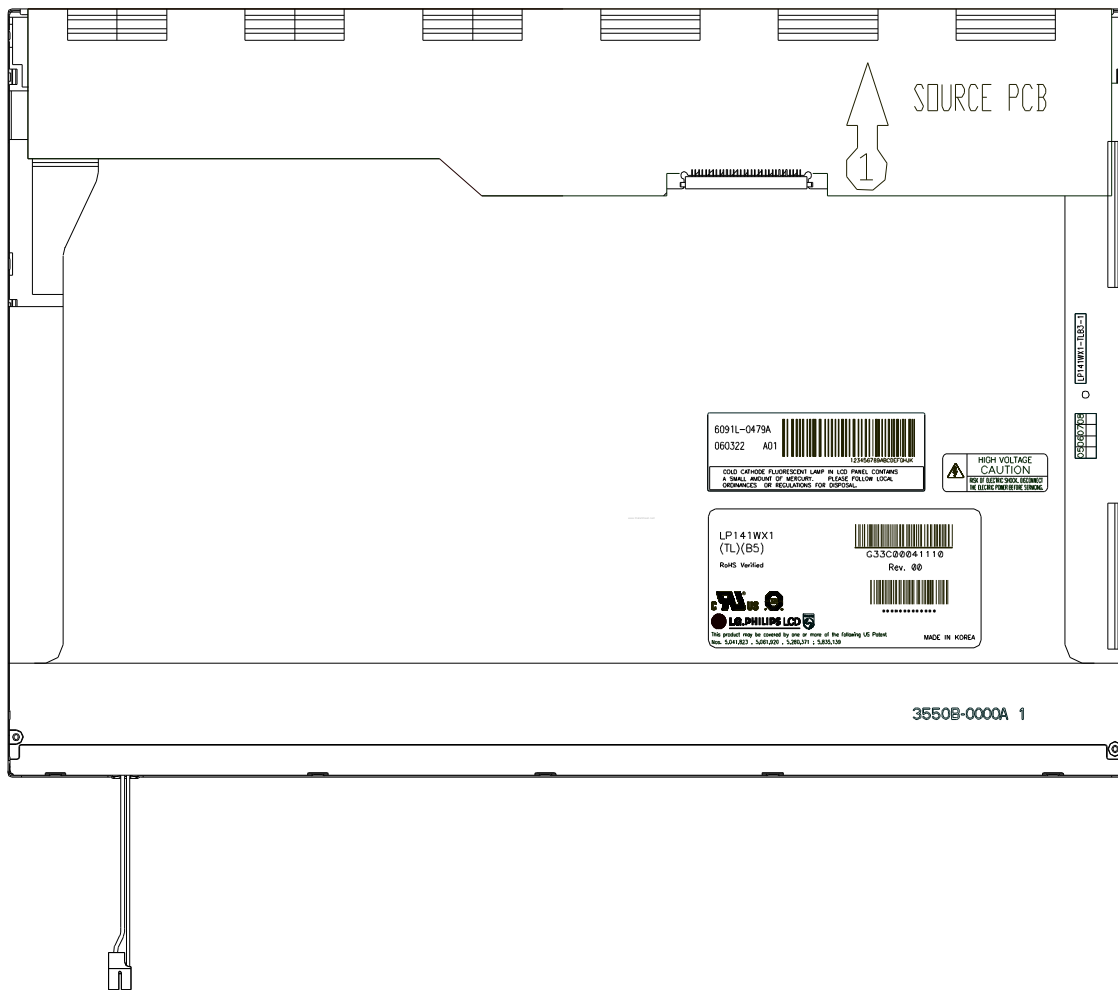

11.5.7. Assembly of Top Case

- (1) ① Assembly of Top Case.

Caution: Pressure should not be given on PCB and COF.

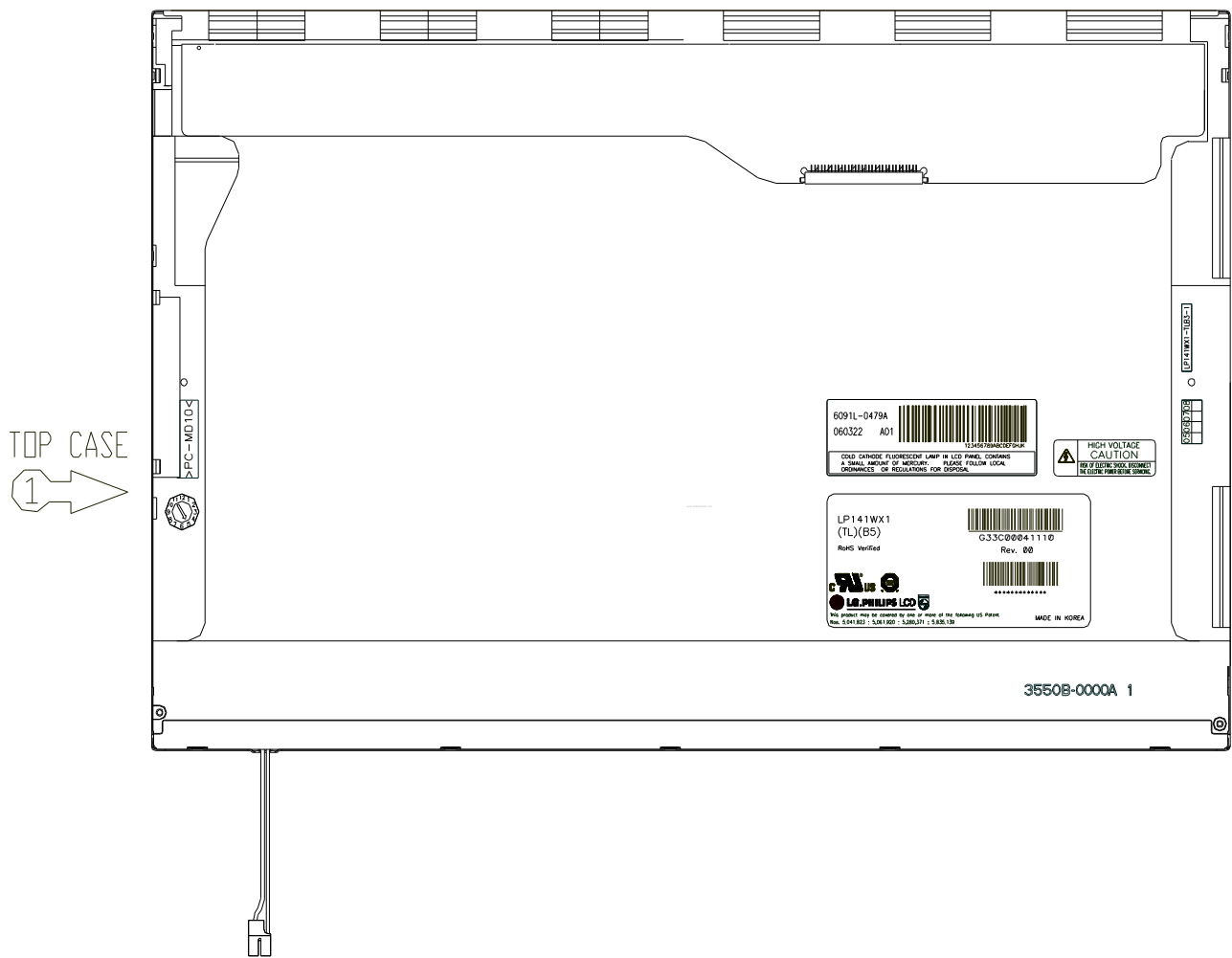

11.5.8. Assembly of outside Tape and Cover shield

(1) ① Assembly of Cover shield(S)

Caution: Pressure or stress should not be given on Source PCB.

Usage of gloves with anti-electric discharge coating is recommended

To eliminate possible damage on circuits occurred by ESC.

(2) ② Assembly of Cover shield(G)

Caution: Pressure or stress should not be given on Gate COF.

(3) ③ Assembly of Tape Adhesive used for Top case fixing

Caution: Pressure or stress should not be given on Top case during this process

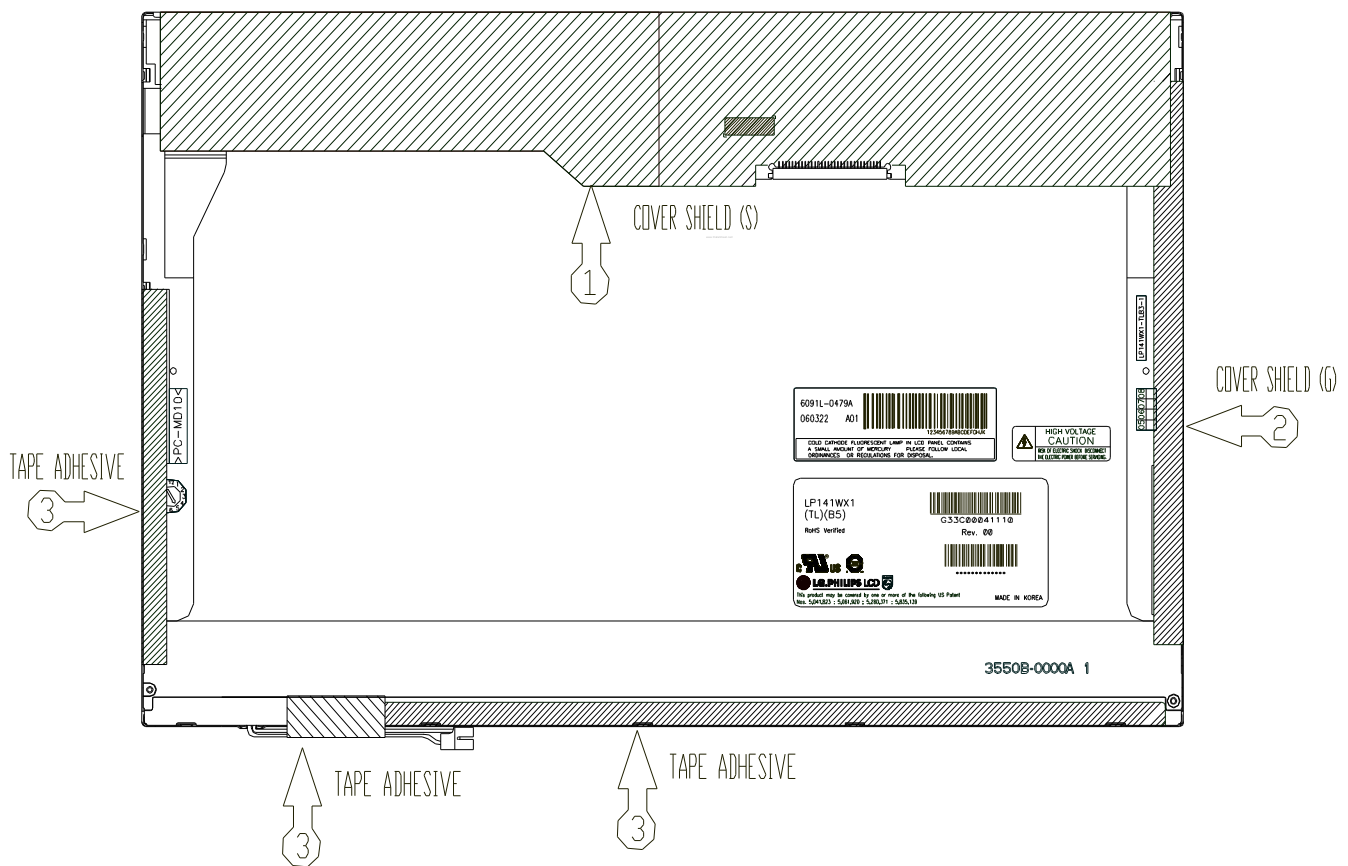

12. General Precaution

Please pay attention to the followings when you use this TFT LCD module.

12.1. Mounting Precautions

- (1) You must mount a module using holes arranged in four corners or four sides.
- (2) You should consider the mounting structure so that uneven force (ex. twisted stress) is not applied to the module. And the case on which a module is mounted should have sufficient strength so that external force is not transmitted directly to the module.
- (3) Please attach a transparent protective plate to the surface in order to protect the polarizer. Transparent protective plate should have sufficient strength in order to resist external force.
- (4) You should adopt radiation structure to satisfy the temperature specification.
- (5) Acetic acid type and chlorine type materials for the cover case aren't desirable because the former generates corrosive gas of attacking the polarizer at high temperature and the latter causes circuit break by electro-chemical reaction.
- (6) Do not touch, push or rub the exposed polarizer with glass, tweezers or anything harder than HB pencil lead. And please do not rub with dust clothes with chemical treatment. Do not touch the surface of polarizer for bare hand or greasy cloth. (Some cosmetics are detrimental to the polarizer.)
- (7) When the surface becomes dusty, please wipe gently with absorbent cotton or other soft materials like chamois soaked with petroleum benzene. Normal-hexane is recommended for cleaning the adhesives used to attach front / rear polarizers. Do not use acetone, toluene and alcohol because they cause chemical damage to the polarizer.
- (8) Wipe off saliva or water drops as soon as possible. Their long time contact with polarizer causes deformations and color fading.
- (9) Do not open the case because inside circuits do not have sufficient strength.

12.2. Operating Precautions

- (1) The spike noise causes the mis-operation of circuits. It should be lower than following voltage
: $V = \pm 200\text{mV}$ (Over and under shoot voltage).
- (2) Response time depends on the temperature. (In lower temperature, it becomes longer.)
- (3) Brightness depends on the temperature. (In lower temperature, it becomes lower.) And in lower temperature, response time (required time that brightness is stable after turned on) becomes longer.
- (4) Be careful for condensation at sudden temperature change. Condensation makes damage to polarizer or electrical contacted parts. And after fading condensation, smear or spot will occur.
- (5) When fixed patterns are displayed for a long time, remnant image is likely to occur.
- (6) A module has high frequency circuit. If you need to shield the electromagnetic noise, please co-work. When a Back-light unit is operating, it sounds. If you need to shield the noise, please co-work.

12.3. Electrostatic Discharge Control

Since a module is composed of electronic circuits, it is not strong to electrostatic discharge. Make certain that treatment persons are connected to ground through wrist band etc . And don't touch interface pin directly.

12.4. Precautions for Strong Light Exposure

Strong light exposure causes degradation of polarizer and color filter.

12.5. Storage

When storing modules as spares for a long time, the following precautions are necessary.

- (1) Store them in a dark place. Do not expose the module to sunlight or fluorescent light. Keep the temperature between 5°C and 35°C at normal humidity.
- (2) The polarizer surface should not come in contact with any other object. It is recommended that they be stored in the container in which they were shipped.

12.6. Handling Precautions for Protection Film

- (1) When the protection film is peeled off, static electricity is generated between the film and polarizer. This should be peeled off slowly and carefully by people who are electrically grounded and with well ion-blown equipment or in such a condition, etc.
- (2) The protection film is attached to the polarizer with a small amount of glue. If some stress is applied to rub the protection film against the polarizer during the time you peel off the film, the glue is apt to remain on the polarizer. Please carefully peel off the protection film without rubbing it against the polarizer.
- (3) When the module with protection film attached is stored for a long time, sometimes there remains a very small amount of glue still on the polarizer after the protection film is peeled off.
- (4) You can remove the glue easily. When the glue remains on the polarizer surface or its vestige is recognized, please wipe them off with absorbent cotton waste or other soft material like chamois soaked with normal-hexane.

APPENDIX A. Enhanced Extended Display Identification Data (EEDID™) 1/3

LP141WX1 - TLB5 E- EDID DATA (ver0.2)

2007.01.23

Byte# (decimal)	Byte# (HEX)	Field Name and Comments	Value (HEX)	Value (binary)		
0	00	Header	0 0	0000 0000	Header	
1	01	Header	F F	1111 1111		
2	02	Header	F F	1111 1111		
3	03	Header	F F	1111 1111		
4	04	Header	F F	1111 1111		
5	05	Header	F F	1111 1111		
6	06	Header	F F	1111 1111		
7	07	Header	0 0	0000 0000		
8	08	EISA manufacturer code(3 Character ID) = LPL	3 2	0011 0010	Vender/ Product ID	
9	09	Compressed ASCII	0 C	0000 1100		
10	0A	Panel Supplier Reserved - Product code	0 0	0000 0000		
11	0B	(Hex, LSB first)	A 9	1010 1001		
12	0C	LCD Module Serial No. = 0 (If not used)	0 0	0000 0000		
13	0D	LCD Module Serial No. = 0 (If not used)	0 0	0000 0000		
14	0E	LCD Module Serial No. = 0 (If not used)	0 0	0000 0000		
15	0F	LCD Module Serial No. = 0 (If not used)	0 0	0000 0000		
16	10	Week of Manufacture = 00	0 0	0000 0000	EDID Version/ Revision	
17	11	Year of Manufacture = 2007	1 1	0001 0001		
18	12	EDID Structure version # = 1	0 1	0000 0001		
19	13	EDID Revision # = 3	0 3	0000 0011		
20	14	Video input definition = Digital I/p,non TMDS CRGB	8 0	1000 0000		Display Parameter
21	15	Max H image size(cm) = 30.374cm (30)	1 E	0001 1110		
22	16	Max V image size(cm) = 18.984cm (19)	1 3	0001 0011		
23	17	Display gamma = 2.2	7 8	0111 1000		
24	18	Feature support(DPMS) = Active off, RGB Color	0 A	0000 1010	Color Characteristic	
25	19	Red/Green low Bits	B 3	1011 0011		
26	1A	Blue/White Low Bits	8 5	1000 0101		
27	1B	Red X Rx = 0.584	9 5	1001 0101		
28	1C	Red Y Ry = 0.347	5 8	0101 1000		
29	1D	Green X Gx = 0.324	5 3	0101 0011		
30	1E	Green Y Gy = 0.542	8 A	1000 1010		
31	1F	Blue X Bx = 0.158	2 8	0010 1000		
32	20	Blue Y By = 0.145	2 5	0010 0101	Established Timings	
33	21	White X Wx = 0.313	5 0	0101 0000		
34	22	White Y Wy = 0.329	5 4	0101 0100		
35	23	Established Timing I	0 0	0000 0000		
36	24	Established Timing II	0 0	0000 0000		
37	25	Manufacturer's Timings	0 0	0000 0000		
38	26	Standard Timing Identification 1 was not used	0 1	0000 0001		Standard Timing ID
39	27	Standard Timing Identification 1 was not used	0 1	0000 0001		
40	28	Standard Timing Identification 2 was not used	0 1	0000 0001		
41	29	Standard Timing Identification 2 was not used	0 1	0000 0001		
42	2A	Standard Timing Identification 3 was not used	0 1	0000 0001		
43	2B	Standard Timing Identification 3 was not used	0 1	0000 0001		
44	2C	Standard Timing Identification 4 was not used	0 1	0000 0001		
45	2D	Standard Timing Identification 4 was not used	0 1	0000 0001		
46	2E	Standard Timing Identification 5 was not used	0 1	0000 0001		
47	2F	Standard Timing Identification 5 was not used	0 1	0000 0001		
48	30	Standard Timing Identification 6 was not used	0 1	0000 0001		
49	31	Standard Timing Identification 6 was not used	0 1	0000 0001		
50	32	Standard Timing Identification 7 was not used	0 1	0000 0001		
51	33	Standard Timing Identification 7 was not used	0 1	0000 0001		
52	34	Standard Timing Identification 8 was not used	0 1	0000 0001		
53	35	Standard Timing Identification 8 was not used	0 1	0000 0001		

APPENDIX A. Enhanced Extended Display Identification Data (EEDID™) 2/3

Byte# (decimal)	Byte# (HEX)	Field Name and Comments	Value (HEX)	Value (binary)		
54	36	1280 X 800 @ 60Hz mode : pixel clock = 71.00MHz	B C	1011 1100	Timing Descriptor #1	
55	37	(Stored LSB first)	1 B	0001 1011		
56	38	Horizontal Active = 1280 pixels	0 0	0000 0000		
57	39	Horizontal Blanking = 160 pixels	A 0	1010 0000		
58	3A	Horizontal Active : Horizontal Blanking = 1280 : 160	5 0	0101 0000		
59	3B	Vertical Active = 800 lines	2 0	0010 0000		
60	3C	Vertical Blanking = 23 lines	1 7	0001 0111		
61	3D	Vertical Active : Vertical Blanking = 800 : 16 => 800 : 23	3 0	0011 0000		
62	3E	Horizontal Sync. Offset = 48 pixels	3 0	0011 0000		
63	3F	Horizontal Sync Pulse Width = 32 pixels	2 0	0010 0000		
64	40	Vertical Sync Offset = 3 lines, Sync Width = 6 lines	3 6	0011 0110		
65	41	Horizontal Vertical Sync Offset/Width upper 2bits = 0	0 0	0000 0000		
66	42	Horizontal Image Size = 303.74mm (304)	3 0	0011 0000		
67	43	Vertical Image Size = 189.84mm (190)	B E	1011 1110		
68	44	Horizontal & Vertical Image Size	1 0	0001 0000		
69	45	Horizontal Border = 0	0 0	0000 0000		
70	46	Vertical Border = 0	0 0	0000 0000		
71	47	Non- interlaced, Normal display, no stereo, Digital separate sync, H/V pol negatives	1 8	0001 1000		
72	48	Detailed Timing Descriptor #2	0 0	0000 0000		Detailed Timing Description #2
73	49		0 0	0000 0000		
74	4A		0 0	0000 0000		
75	4B	Monitor name	F C	1111 1100		
76	4C	Flag	0 0	0000 0000		
77	4D	1st character of name("L")	4 C	0100 1100		
78	4E	2nd character of name("P")	5 0	0101 0000		
79	4F	3rd character of name("1")	3 1	0011 0001		
80	50	4th character of name("4")	3 4	0011 0100		
81	51	4th character of name("1")	3 1	0011 0001		
82	52	5th character of name("W")	5 7	0101 0111		
83	53	6th character of name("X")	5 8	0101 1000		
84	55	7th character of name("1")	3 1	0011 0001		
85	55	8th character of name("-")	2 D	0010 1101		
86	56	9th character of name("T")	5 4	0101 0100		
87	57	10th character of name("L")	4 C	0100 1100		
88	58	11th character of name("B")	4 2	0100 0010		
89	59	12th character of name("5")	3 5	0011 0101		
90	5A	Detailed Timing Descriptor #3	0 0	0000 0000	Detailed Timing Description #3	
91	5B		0 0	0000 0000		
92	5C		0 0	0000 0000		
93	5D	Monitor range limits, binary coded	F D	1111 1101		
94	5E		0 0	0000 0000		
95	5F	Vertical Frequency Min : 55.94Hz	3 8	0011 1000		
96	60	Vertical Frequency Max : 63.28Hz	3 F	0011 1111		
97	61	Horizontal Frequency Min : 46.04KHz	2 E	0010 1110		
98	62	Horizontal Frequency Max : 52.08KHz	3 4	0011 0100		
99	63	Pixel Clock Max : 75MHz	0 7	0000 0111		
100	64	Secondary GTF	0 0	0000 0000		
101	65		0 0	0000 0000		
102	66		0 0	0000 0000		
103	67		0 0	0000 0000		
104	68		0 0	0000 0000		
105	69		0 0	0000 0000		
106	6A		0 0	0000 0000		
107	6B		0 0	0000 0000		

APPENDIX A. Enhanced Extended Display Identification Data (EEDID™) 3/3

Byte# (decimal)	Byte# (HEX)	Field Name and Comments	Value (HEX)	Value (binary)	
108	6C	Detailed Timing Descriptor #4	0 0	0000 0000	Detailed Timing Description #4
109	6D		0 0	0000 0000	
110	6E		0 0	0000 0000	
111	6F		F E	1111 1110	
112	70		0 0	0000 0000	
113	71	1st character of name("L")	4 C	0100 1100	
114	72	2nd character of name("P")	5 0	0101 0000	
115	73	3rd character of name("1")	3 1	0011 0001	
116	74	4th character of name("4")	3 4	0011 0100	
117	75	4th character of name("1")	3 1	0011 0001	
118	76	5th character of name("W")	5 7	0101 0111	
119	77	6th character of name("X")	5 8	0101 1000	
120	78	7th character of name("1")	3 1	0011 0001	
121	79	8th character of name("-")	2 D	0010 1101	
122	7A	9th character of name("T")	5 4	0101 0100	
123	7B	10th character of name("L")	4 C	0100 1100	
124	7C	11th character of name("B")	4 2	0100 0010	
125	7D	12th character of name("5")	3 5	0011 0101	
126	7E	Extension flag = 00	0 0	0000 0000	Extension Flag
127	7F	Checksum	8 7	1000 0111	Checksum