

Product Specification

# SPECIFICATION FOR APPROVAL

- ( ● ) Preliminary Specification  
(   ) Final Specification

Title	14.1" WXGA TFT LCD
-------	--------------------

Customer	Lenovo
MODEL	

SUPPLIER	LG.Philips LCD Co., Ltd.
*MODEL	LP141WX3
Suffix	TLA5

\*When you obtain standard approval,  
please use the above model name without suffix

SIGNATURE	DATE
/	_____
/	_____
/	_____

Please return 1 copy for your confirmation with your signature and comments.

SIGNATURE	DATE
S. C. Yun / G.Manager	_____
<b>REVIEWED BY</b>	
K. T. Moon / Manager	_____
<b>PREPARED BY</b>	
D. G. Choi / Engineer	_____

**Products Engineering Dept.  
LG. Philips LCD Co., Ltd**

Product Specification

Contents

No	ITEM	Page
	COVER	1
	CONTENTS	2
	RECORD OF REVISIONS	3
1	GENERAL DESCRIPTION	4
2	ABSOLUTE MAXIMUM RATINGS	5
3	ELECTRICAL SPECIFICATIONS	
3-1	ELECTRICAL CHARACTERISTICS	6
3-2	INTERFACE CONNECTIONS	7
3-3	SIGNAL TIMING SPECIFICATIONS	9
3-4	SIGNAL TIMING WAVEFORMS	9
3-5	COLOR INPUT DATA REFERENCE	10
3-6	POWER SEQUENCE	11
4	OPTICAL SPECIFICATIONS	12
5	MECHANICAL CHARACTERISTICS	16
6	RELIABILITY	20
7	INTERNATIONAL STANDARDS	
7-1	SAFETY	21
7-2	EMC	21
8	PACKING	
8-1	DESIGNATION OF LOT MARK	22
8-2	PACKING FORM	22
8-3	Label Description	23
9	PRECAUTIONS	24
A	APPENDIX. Enhanced Extended Display Identification Data	26



Product Specification

### 1. General Description

The LP141WX3 is a Color Active Matrix Liquid Crystal Display with an integral Cold Cathode Fluorescent Lamp (CCFL) backlight system. The matrix employs a-Si Thin Film Transistor as the active element. It is a transmissive type display operating in the normally white mode. This TFT-LCD has 14.1 inches diagonally measured active display area with WXGA resolution(800 vertical by 1280 horizontal pixel array). Each pixel is divided into Red, Green and Blue sub-pixels or dots which are arranged in vertical stripes. Gray scale or the brightness of the sub-pixel color is determined with a 6-bit gray scale signal for each dot, thus, presenting a palette of more than 262,144 colors.

The LP141WX3 has been designed to apply the interface method that enables low power, high speed, low EMI.

The LP141WX3 is intended to support applications where thin thickness, low power are critical factors and graphic displays are important. In combination with the vertical arrangement of the sub-pixels, the LP141WX3 characteristics provide an excellent flat display for office automation products such as Notebook PC.

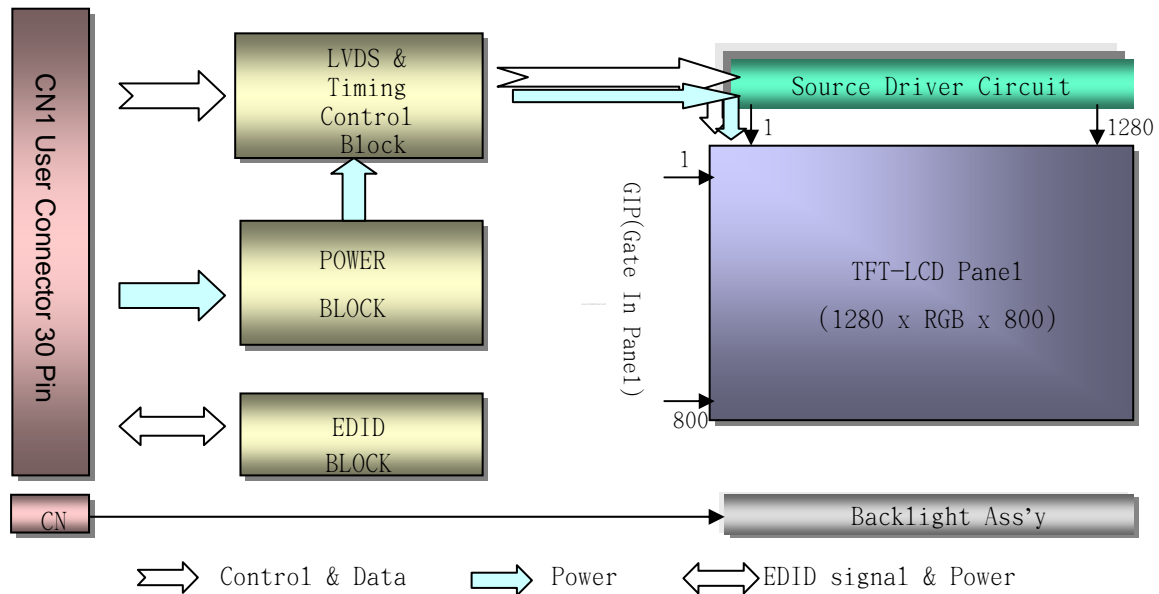

### General Features

Active Screen Size	14.1 inches diagonal
Outline Dimension	320.0(H) × 206.0(V) × 5.5(D) [mm] (Max.)
Pixel Pitch	0.2373 mm × 0.2373 mm
Pixel Format	1280 horiz. By 800 vert. Pixels RGB strip arrangement
Color Depth	6-bit, 262,144 colors
Luminance, White	185 cd/m <sup>2</sup> (Typ.5 point)
Power Consumption (Window Desk Top Pattern)	Total 5.2 Watt(Typ.) @ LCM circuit 1.2Watt(Typ.), B/L input 4.0Watt(Typ.)
Weight	400g(Max.), 390g(Typ.)
Display Operating Mode	Transmissive mode, normally white
Surface Treatment	Haze44% (ARC150T)
RoHS Comply	Yes

Product Specification

## 2. Absolute Maximum Ratings

The following are maximum values which, if exceeded, may cause faulty operation or damage to the unit.

**Table 1. ABSOLUTE MAXIMUM RATINGS**

Parameter	Symbol	Values		Units	Notes
		Min	Max		
Power Input Voltage	VCC	-0.3	4.0	Vdc	at 25 ± 5°C
Operating Temperature	TOP	0	50	°C	1
Storage Temperature	HST	-20	60	°C	1
Operating Ambient Humidity	HOP	10	90	%RH	1
Storage Humidity	HST	10	90	%RH	1

Note : 1. Temperature and relative humidity range are shown in the figure below.  
 Wet bulb temperature should be 39°C Max, and no condensation of water.

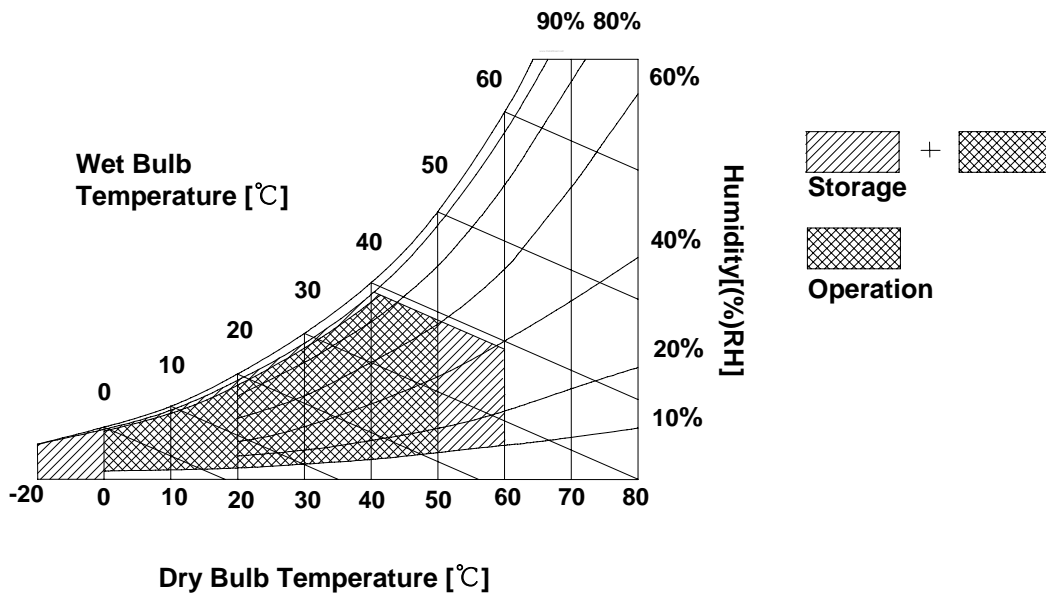

Product Specification

### 3. Electrical Specifications

#### 3-1. Electrical Characteristics

The LP141WX3 requires two power inputs. One is employed to power the LCD electronics and to drive the TFT array and liquid crystal. The second input which powers the CCFL, is typically generated by an inverter. The inverter is an external unit to the LCD.

**Table 2. ELECTRICAL CHARACTERISTICS**

Parameter	Symbol	Values			Unit	Notes
		Min	Typ	Max		
<b>MODULE :</b>						
Power Supply Input Voltage	VCC	3.0	3.3	3.6	V <sub>DC</sub>	
Power Supply Input Current (window Desk Top Pattern)	I <sub>CC</sub>	-	400 (355)	460 (405)	mA	1
Power Consumption (window Desk Top Pattern)	P <sub>C</sub>	-	1.32 (1.17)	1.52 (1.34)	Watt	1
Differential Impedance	Z <sub>m</sub>	90	100	110	Ohm	2
<b>LAMP :</b>						
Operating Voltage	V <sub>BL</sub>	645(6.5mA)	660(6.0mA)	880(2.0mA)	V <sub>RMS</sub>	
Operating Current	I <sub>BL</sub>	2.0	6.0	6.5	mA <sub>RMS</sub>	3
Power Consumption	P <sub>BL</sub>	-	4.00	4.30		
Operating Frequency	f <sub>BL</sub>	45	60	80	kHz	
Discharge Stabilization Time	T <sub>s</sub>	-	-	3	Min	4
Life Time		15,000	-	-	Hrs	5
Established Starting Voltage at 25°C at 0°C	V <sub>s</sub>			1180 1400	V <sub>RMS</sub> V <sub>RMS</sub>	

Note)

- The specified current and power consumption are under the Vcc = 3.3V , 25°C, fv = 60Hz condition whereas full black pattern(Window Desk Top Pattern) is displayed and fv is the frame frequency.
- This impedance value is needed to proper display and measured form LVDS Tx to the mating connector.
- The typical operating current is for the typical surface luminance (L<sub>WH</sub>) in optical characteristics.
- Define the brightness of the lamp after being lighted for 5 minutes as 100%, Ts is the time required for the brightness of the center of the lamp to be not less than 95%.
- The life time is determined as the time at which brightness of lamp is 50% compare to that of initial value at the typical lamp current.
- The output of the inverter must have symmetrical(negative and positive) voltage waveform and symmetrical current waveform.(Asymmetrical ratio is less than 10%) Please do not use the inverter which has asymmetrical voltage and asymmetrical current and spike wave.  
Lamp frequency may produce interface with horizontal synchronous frequency and as a result this may cause beat on the display. Therefore lamp frequency shall be as away possible from the horizontal synchronous frequency and from its harmonics in order to prevent interference.
- It is defined the brightness of the lamp after being lighted for 5 minutes as 100%.  
T<sub>s</sub> is the time required for the brightness of the center of the lamp to be not less than 95%.
- The lamp power consumption shown above does not include loss of external inverter.  
The applied lamp current is a typical one.

Product Specification

Note)

9. Requirements for a system inverter design, which is intended to have a better display performance, a better power efficiency and a more reliable lamp, are following.

It shall help increase the lamp lifetime and reduce leakage current.

- a. The asymmetry rate of the inverter waveform should be less than 10%.
- b. The distortion rate of the waveform should be within  $\sqrt{2} \pm 10\%$ .

\* Inverter output waveform had better be more similar to ideal sine wave.

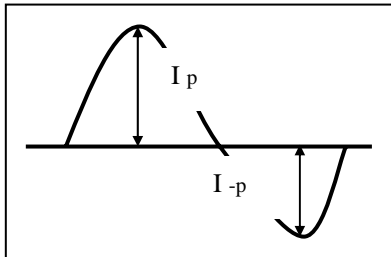

\* Asymmetry rate:

$$|I_p - I_{-p}| / I_{rms} * 100\%$$

\* Distortion rate

$$I_p \text{ (or } I_{-p}) / I_{rms}$$

※ Do not attach a conducting tape to lamp connecting wire.

If the lamp wire attach to a conducting tape, TFT-LCD Module has a low luminance and the inverter has abnormal action. Because leakage current is occurred between lamp wire and conducting tape.

Product Specification

### 3-2. Interface Connections

This LCD employs two interface connections, a 30 pin connector is used for the module electronics interface and the other connector is used for the integral backlight system.

The electronics interface connector is a model GT101-30S-HR11 manufactured by LGC.

**Table 3. MODULE CONNECTOR PIN CONFIGURATION (CN1)**

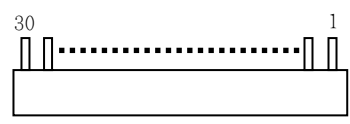
Pin	Symbol	Description	Notes
1	GND	Ground	<p>1. Interface chips 1.1 LCD : THINE , KE5M5U2654 (LCD Controller) including LVDS Receiver (LVDSRX_SPI_UMOD ) 1.2 System : it must include international standard LVDS Transmitter. * Pin to Pin compatible with LVDS</p> <p>2. Connector 2.1 LCD : GT101-30S-HR11, LGC 2.2 Mating : FI-X30M or equivalent. 2.3 Connector pin arrangement</p>  <p>[LCD Module Rear View]</p>
2	VCC	Power Supply, 3.3V Typ.	
3	VCC	Power Supply, 3.3V Typ.	
4	V EEDID	DDC 3.3V power	
5	NC	Reserved for supplier test point	
6	CLK EEDID	DDC Clock	
7	DATA EEDID	DDC Data	
8	R <sub>IN</sub> 0-	Negative LVDS differential data input	
9	R <sub>IN</sub> 0+	Positive LVDS differential data input	
10	GND	Ground	
11	R <sub>IN</sub> 1-	Negative LVDS differential data input	
12	R <sub>IN</sub> 1+	Positive LVDS differential data input	
13	GND	Ground	
14	R <sub>IN</sub> 2-	Negative LVDS differential data input	
15	R <sub>IN</sub> 2+	Positive LVDS differential data input	
16	GND	Ground	
17	CLKIN-	Negative LVDS differential clock input	
18	CLKIN+	Positive LVDS differential clock input	
19	GND	Ground	
20	NC	No Connect	
21	NC	No Connect	
22	GND	Ground	
23	NC	No Connect	
24	NC	No Connect	
25	GND	Ground	
26	NC	No Connect	
27	NC	No Connect	
28	GND	Ground	
29	NC	No Connect	
30	NC	No Connect	

The backlight interface connector is a model BHSR-02VS-1, manufactured by JST  
The mating connector part number is SM02B-BHSS-1 or equivalent.

**Table 5. BACKLIGHT CONNECTOR PIN CONFIGURATION (J3)**

Pin	Symbol	Description	Notes
1	HV	Power supply for lamp (High voltage side)	1
2	LV	Power supply for lamp (Low voltage side)	1

Notes : 1. The high voltage side terminal is colored Pink and the low voltage side terminal is White.



### 3-3. Signal Timing Specifications

This is the signal timing required at the input of the User connector. All of the interface signal timing should be satisfied with the following specifications and specifications of LVDS Tx/Rx for its proper operation.

**Table 6. TIMING TABLE**

ITEM	Symbol	Min	Typ	Max	Unit	Note	
DCLK	Frequency	$f_{CLK}$	65.5	69.3	75.8	MHz	1
Hsync	Period	$T_{hp}$	1352	1405	1488	tCLK	
	Width	$t_{WH}$	16	32	48		
	Width-Active	$t_{WHA}$	1280	1280	1280		
Vsync	Period	$t_{VP}$	808	822	849	tHP	
	Width	$t_{WV}$	2	6	8		
	Width-Active	$t_{WVA}$	800	800	800		
Data Enable	Horizontal back porch	$t_{HBP}$	40	45	104	tCLK	
	Horizontal front porch	$t_{HFP}$	16	48	56		
	Vertical back porch	$t_{VBP}$	5	13	35	tHP	
	Vertical front porch	$t_{VFP}$	1	3	6		

Note)

- In this documentation, all reliabilities are specified for timing specification based on refresh rate of 60Hz. However, LP141WX3 has a good actual performance even at lower refresh rate( eg. 40Hz or 50Hz) for power saving mode, whereas LP141WX3 is secured only for function under lower refresh rate. 60Hz at Normal mode, 50Hz ,40 Hz at Power save mode. Don't care Flicker level (power save mode).

### 3-4. Signal Timing Waveforms

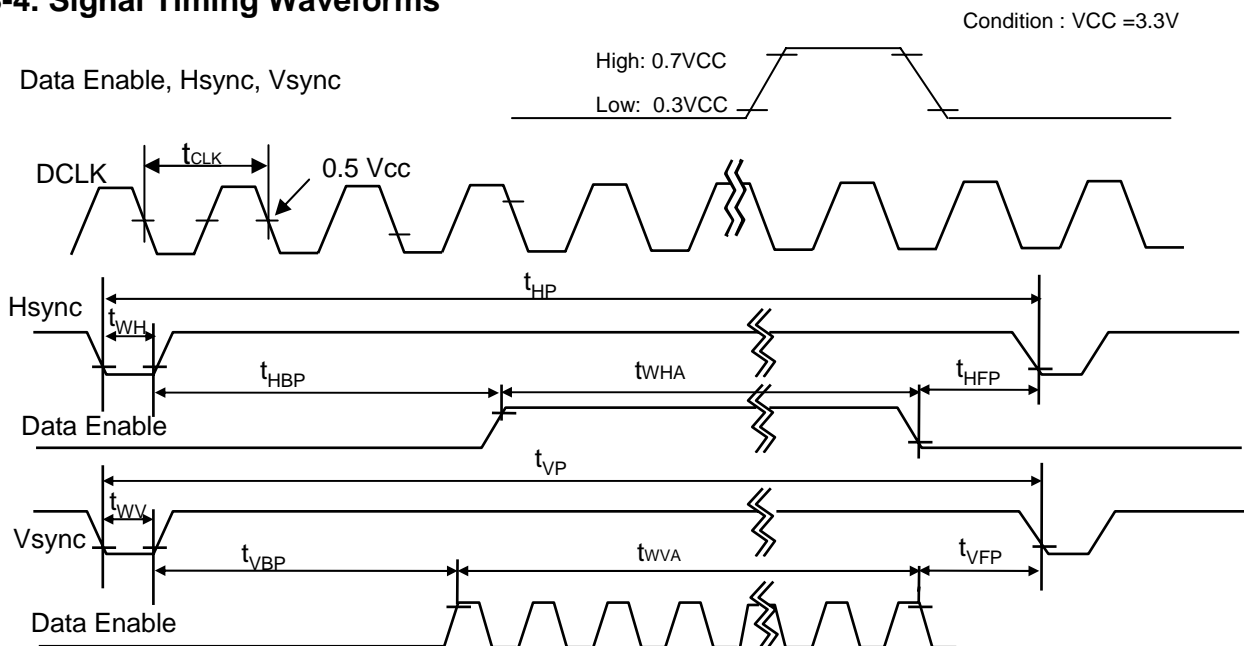

Product Specification

### 3-5. Color Input Data Reference

The brightness of each primary color (red, green and blue) is based on the 6-bit gray scale data input for the color ; the higher the binary input, the brighter the color. The table below provides a reference for color versus data input.

**Table 7. COLOR DATA REFERENCE**

Color		Input Color Data																	
		RED						GREEN						BLUE					
		MSB				LSB		MSB				LSB		MSB		LSB			
		R 5	R 4	R 3	R 2	R 1	R 0	G 5	G 4	G 3	G 2	G 1	G 0	B 5	B 4	B 3	B 2	B 1	B 0
Basic Color	Black	0	0	0	0	0	0	0	0	0	0	0	0	0	0	0	0	0	0
	Red	1	1	1	1	1	1	0	0	0	0	0	0	0	0	0	0	0	0
	Green	0	0	0	0	0	0	1	1	1	1	1	1	0	0	0	0	0	0
	Blue	0	0	0	0	0	0	0	0	0	0	0	0	1	1	1	1	1	1
	Cyan	0	0	0	0	0	0	1	1	1	1	1	1	1	1	1	1	1	1
	Magenta	1	1	1	1	1	1	0	0	0	0	0	0	1	1	1	1	1	1
	Yellow	1	1	1	1	1	1	1	1	1	1	1	1	0	0	0	0	0	0
	White	1	1	1	1	1	1	1	1	1	1	1	1	1	1	1	1	1	1
RED	RED (00)	0	0	0	0	0	0	0	0	0	0	0	0	0	0	0	0	0	0
	RED (01)	0	0	0	0	0	1	0	0	0	0	0	0	0	0	0	0	0	0
	...																		
	RED (62)	1	1	1	1	1	0	0	0	0	0	0	0	0	0	0	0	0	0
	RED (63)	1	1	1	1	1	1	0	0	0	0	0	0	0	0	0	0	0	0
GREEN	GREEN (00)	0	0	0	0	0	0	0	0	0	0	0	0	0	0	0	0	0	0
	GREEN (01)	0	0	0	0	0	0	0	0	0	0	0	1	0	0	0	0	0	0
	...																		
	GREEN (62)	0	0	0	0	0	0	1	1	1	1	1	0	0	0	0	0	0	0
	GREEN (63)	0	0	0	0	0	0	1	1	1	1	1	1	0	0	0	0	0	0
BLUE	BLUE (00)	0	0	0	0	0	0	0	0	0	0	0	0	0	0	0	0	0	0
	BLUE (01)	0	0	0	0	0	0	0	0	0	0	0	0	0	0	0	0	0	1
	...																		
	BLUE (62)	0	0	0	0	0	0	0	0	0	0	0	0	1	1	1	1	1	0
	BLUE (63)	0	0	0	0	0	0	0	0	0	0	0	0	1	1	1	1	1	1

### 3-6. Power Sequence

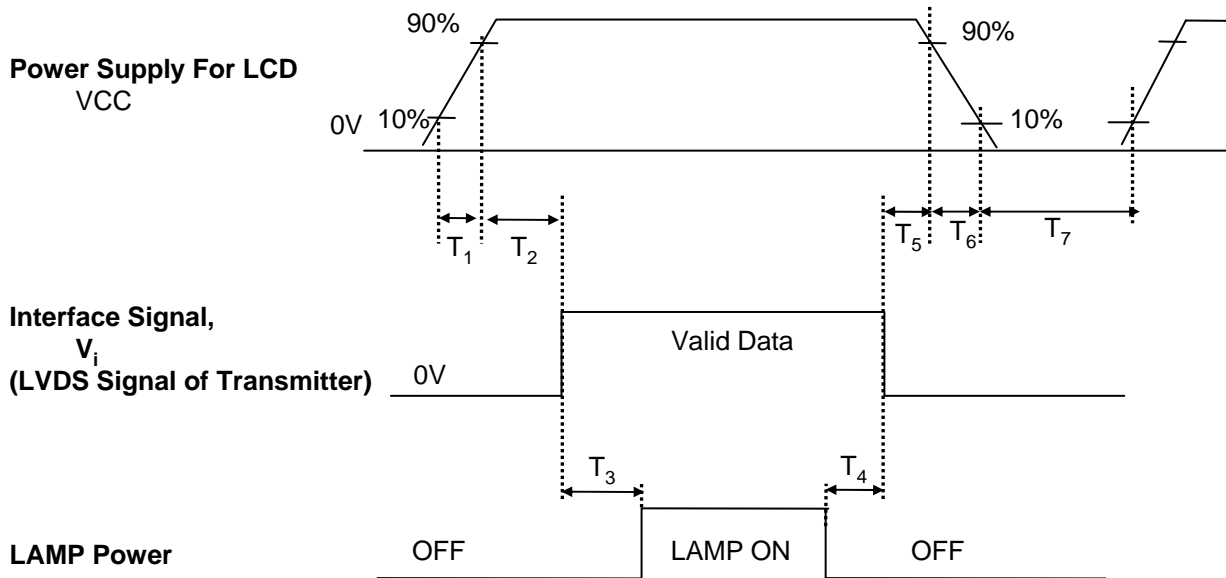

**Table 8. POWER SEQUENCE TABLE**

Parameter	Value			Units
	Min.	Typ.	Max.	
$T_1$	-	-	10	(ms)
$T_2$	0	-	50	(ms)
$T_3$	200	-	-	(ms)
$T_4$	0	-	-	(ms)
$T_5$	0	-	50	(ms)
$T_6$	0	-	10	(ms)
$T_7$	150	-	-	(ms)

Note)

1. Please avoid floating state of interface signal at invalid period.
2. When the interface signal is invalid, be sure to pull down the power supply for LCD VCC to 0V.
3. Lamp power must be turn on after power supply for LCD and interface signal are valid.

Product Specification

4. Optical Specification

Optical characteristics are determined after the unit has been 'ON' and stable for approximately 30 minutes in a dark environment at 25°C. The values specified are at an approximate distance 50cm from the LCD surface at a viewing angle of  $\Phi$  and  $\Theta$  equal to 0°.

FIG. 1 presents additional information concerning the measurement equipment and method.

FIG. 1 Optical Characteristic Measurement Equipment and Method

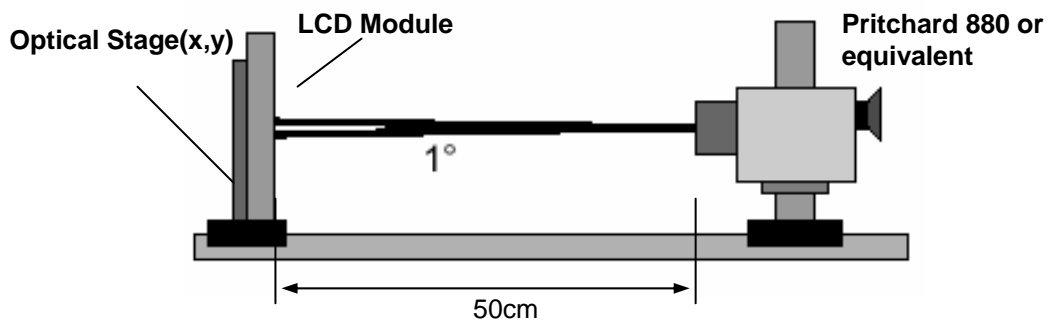

Table 9. OPTICAL CHARACTERISTICS

Ta=25°C, VCC=3.3V, fv=60Hz, fCLK= 69.3MHz, IBL= 6.0mA

Parameter	Symbol	Values			Units	Notes
		Min	Typ	MAx		
Contrast Ratio	CR	-	300	-		1
Surface Luminance, white	L <sub>WH</sub>	155	185	-	cd/m <sup>2</sup>	2
Luminance Variation(5P)		75%	-			3
Luminance Variation(13P)	$\delta_{\text{WHITE}}$	60%				4
Response Time						
Rise Time	T <sub>R</sub>	-	5.5	9	ms	
Delay Time	T <sub>D</sub>	-	10.5	16	ms	
Color Coordinates						
RED	RX	0.554	0.584	0.614		
	RY	0.317	0.347	0.377		
GREEN	GX	0.294	0.324	0.354		
	GY	0.512	0.542	0.572		
BLUE	BX	0.128	0.158	0.188		
	BY	0.115	0.145	0.175		
WHITE	WX	0.285	0.313	0.341		+/- 0.028
	WY	0.309	0.329	0.349		+/- 0.020
Viewing Angle						5
x axis, right( $\Phi=0^\circ$ )	$\Theta_r$	40	45	-	degree	
x axis, left ( $\Phi=180^\circ$ )	$\Theta_l$	40	45	-	degree	
y axis, up ( $\Phi=90^\circ$ )	$\Theta_u$	15	20	-	degree	
y axis, down ( $\Phi=270^\circ$ )	$\Theta_d$	35	40	-	degree	
Gray Scale						6

Product Specification

Note)

1. Contrast Ratio(CR) is defined mathematically as

$$\text{Contrast Ratio} = \frac{\text{Surface Luminance with all white pixels}}{\text{Surface Luminance with all black pixels}}$$

2. Surface luminance is the average of 5 point across the LCD surface 50cm from the surface with all pixels displaying white. For more information see FIG 1.

$$L_{WH} = \text{Average}(L_1, L_2, \dots L_5)$$

3. The variation in surface luminance , The panel total variation ( $\delta_{WHITE}$ ) is determined by measuring  $L_N$  at each test position 1 through 13 and then defined as followed numerical formula.  
For more information see FIG 2.

$$\delta_{WHITE} = \frac{\text{Minimum}(L_1, L_2, \dots L_{13})}{\text{Maximum}(L_1, L_2, \dots L_{13})}$$

4. Response time is the time required for the display to transition from white to black (rise time,  $Tr_R$ ) and from black to white(Decay Time,  $Tr_D$ ). For additional information see FIG 3.

5. Viewing angle is the angle at which the contrast ratio is greater than 10. The angles are determined for the horizontal or x axis and the vertical or y axis with respect to the z axis which is normal to the LCD surface. For more information see FIG 4.

6. Gray scale specification

\*  $f_V = 60\text{Hz}$

Gray Level	Luminance [%] (Typ)
L0	0.21
L7	1.99
L15	6.16
L23	11.96
L31	19.2
L39	33.1
L47	53.2
L55	77.4
L63	100

Product Specification

**FIG. 2 Luminance**

<measuring point for surface luminance & measuring point for luminance variation>

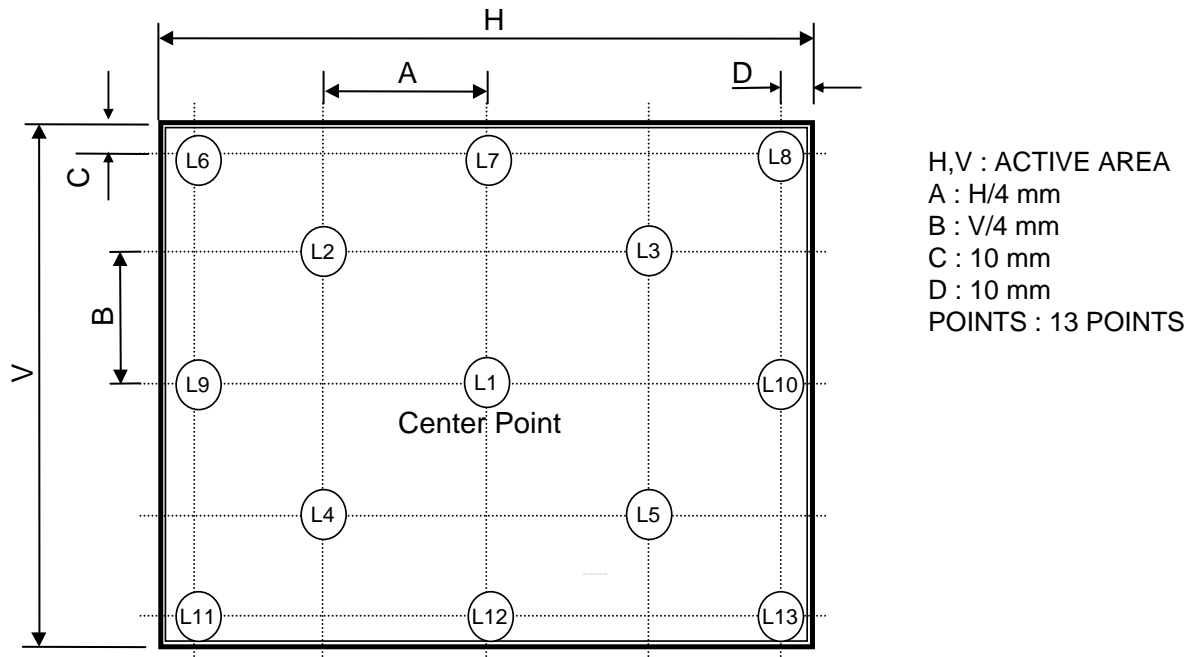

**FIG. 3 Response Time**

The response time is defined as the following figure and shall be measured by switching the input signal for “black” and “white”.

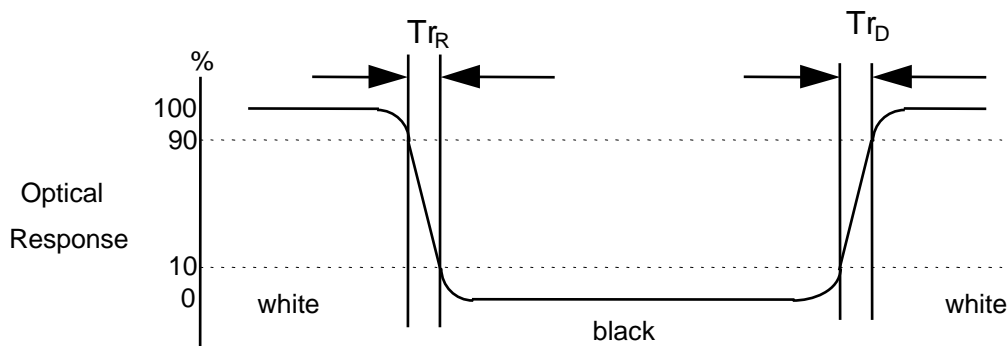
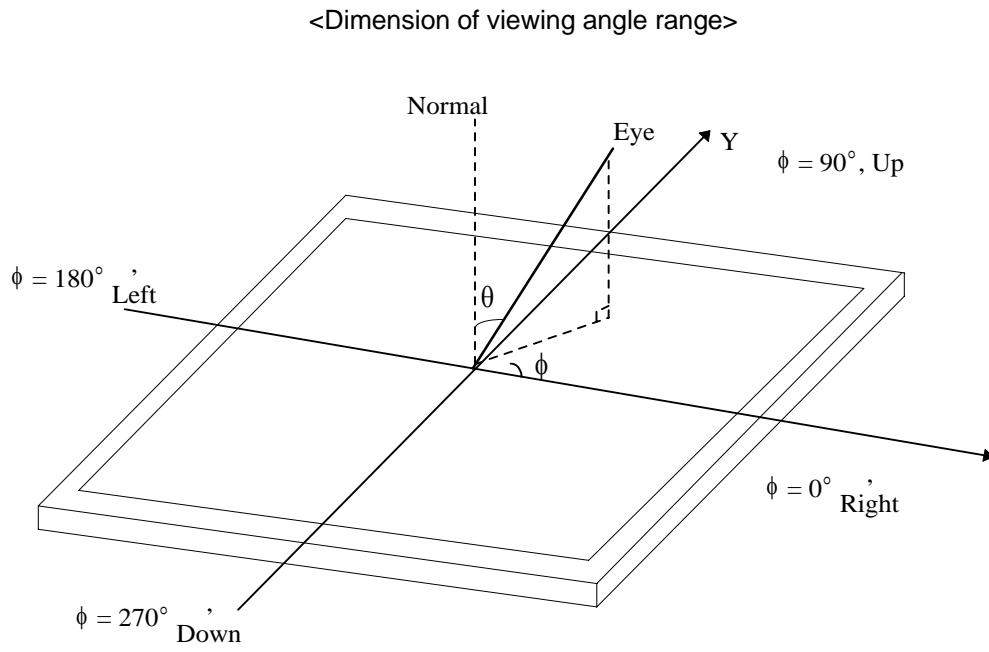

FIG. 4 Viewing angle



Product Specification

### 5. Mechanical Characteristics

The contents provide general mechanical characteristics for the model LP141WX3. In addition the figures in the next page are detailed mechanical drawing of the LCD.

Outline Dimension	Horizontal	319.5 ± 0.5mm
	Vertical	205.5 ± 0.5mm
	Depth	5.5mm (Max.)
Bezel Area	Horizontal	306.76 ± 0.5mm
	Vertical	194.60 ± 0.5mm
Active Display Area	Horizontal	303.74 mm
	Vertical	189.84 mm
Weight	390g (Typ.) 400g (Max.)	
Surface Treatment	Haze 44% (ARC150T)	



Product Specification

<FRONT VIEW>

Note) Unit:[mm], General tolerance:  $\pm 0.5$ mm

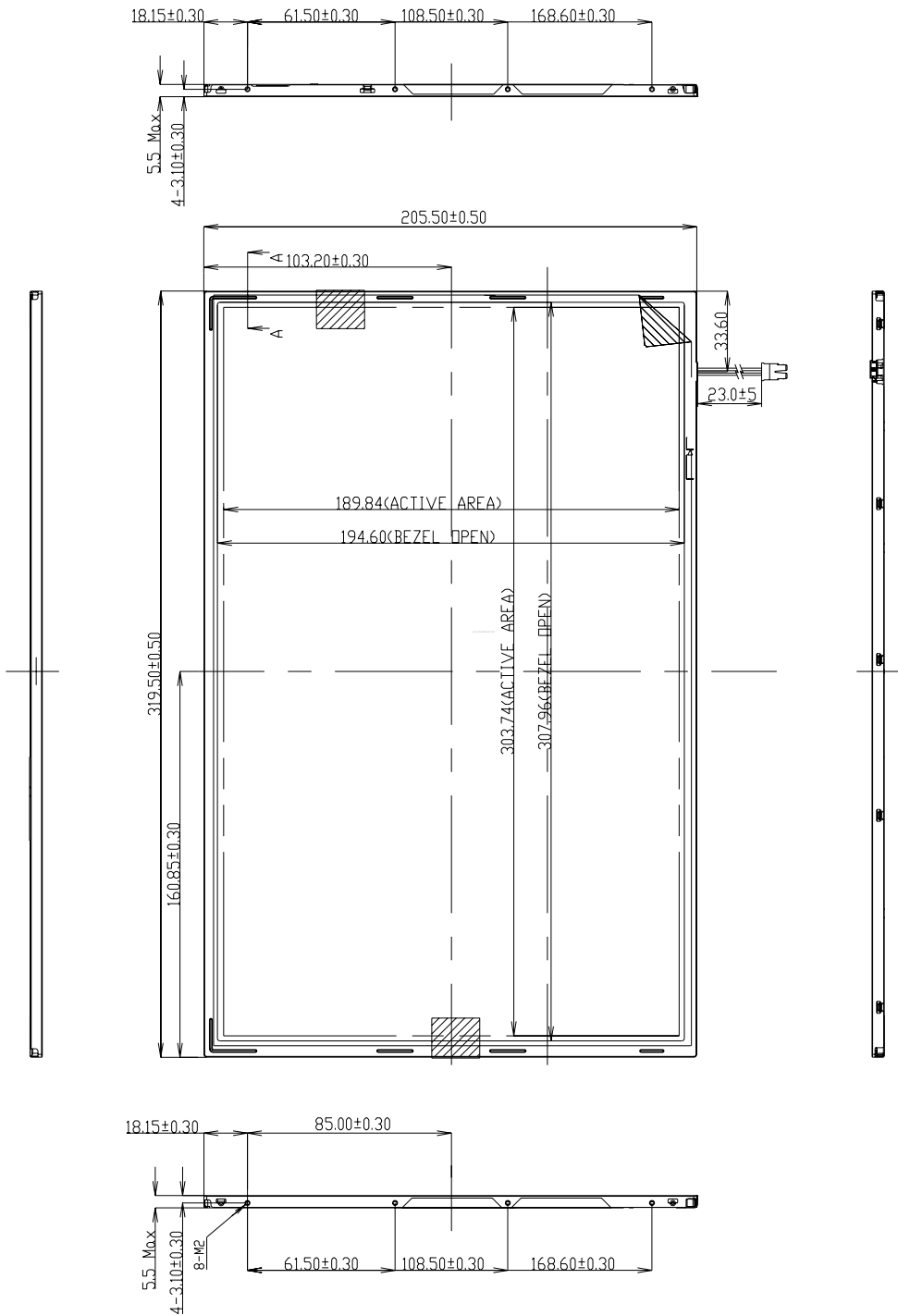

Lamp wire Length : 23.0±5 mm

Product Specification

<REAR VIEW>

Note) Unit:[mm], General tolerance:  $\pm 0.5\text{mm}$

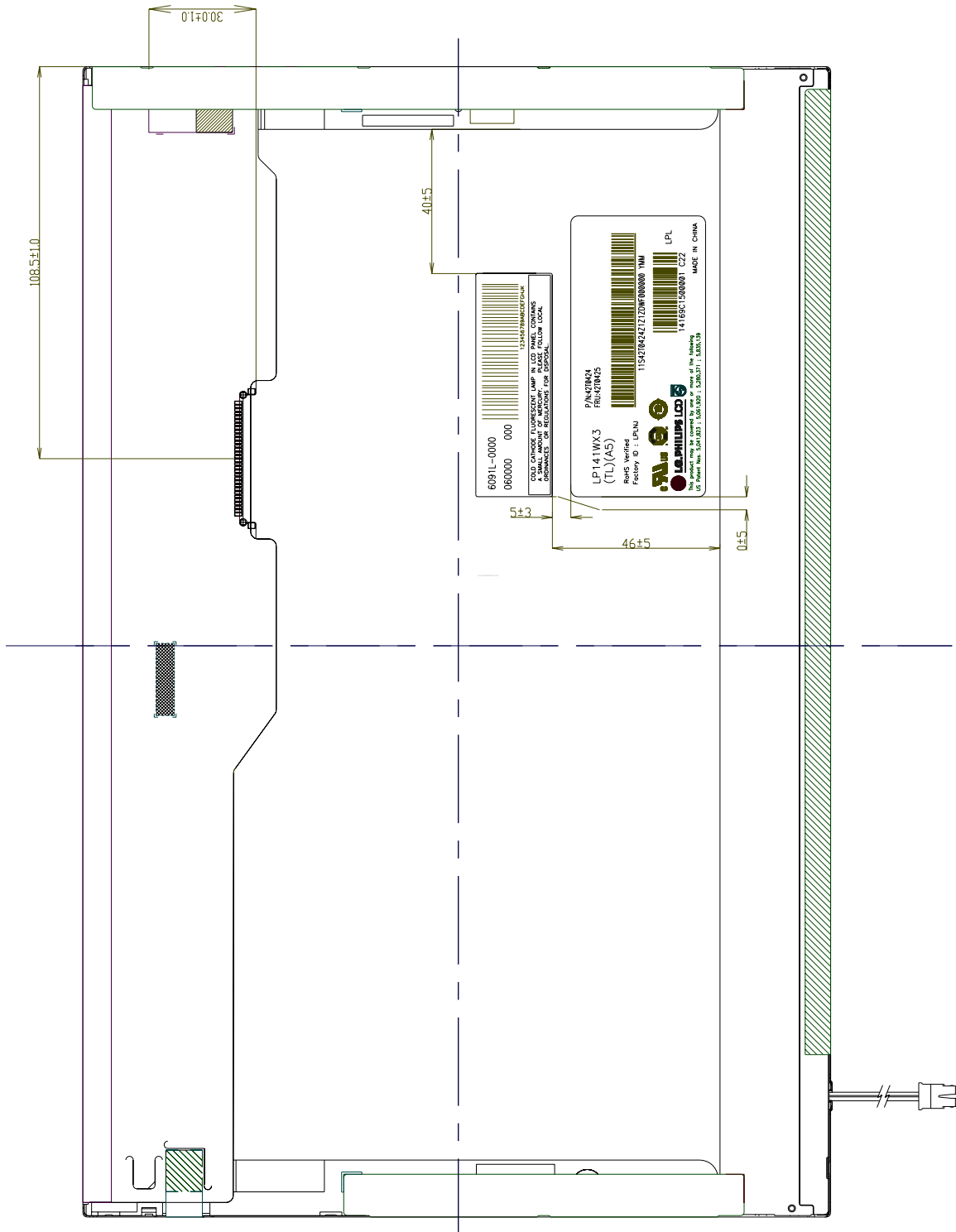

Product Specification

[ DETAIL DESCRIPTION OF SIDE MOUNTING SCREW ]

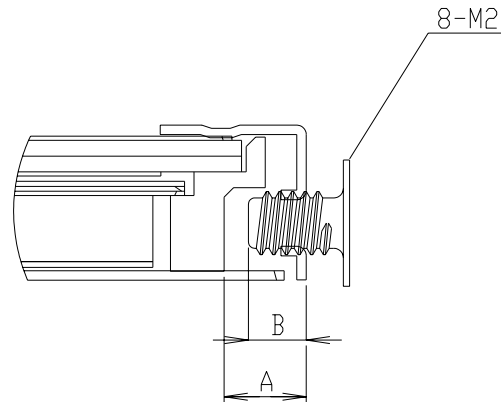

SECTION A-A  
SCALE 5/1

- \*Screw(8ea) Torque : 2kgf.cm max
- \*Screw Hole Depth(A) : 2.5mm min
- \*Screw Length(B) : Max 2.5mm, Min 2.0mm

Note) Unit:[mm], General tolerance:  $\pm 0.5$ mm

Product Specification

## 6. Reliability

Environment test condition

No.	Test Item	Conditions
1	High temperature storage test	Ta= 60°C, 240h
2	Low temperature storage test	Ta= -20°C, 240h
3	High temperature operation test	Ta= 50°C, 50%RH, 240h
4	Low temperature operation test	Ta= 0°C, 240h
5	Vibration test (non-operating)	Sine wave, 10 ~ 500 ~ 10Hz, 1.5G, 0.37oct/min 3 axis, 1hour/axis
6	Shock test (non-operating)	Half sine wave, 180G, 2ms one shock of each six faces
7	Altitude operating storage / shipment	0 ~ 10,000 feet (3,048m) 24Hr 0 ~ 40,000 feet (12,192m) 24Hr

{ Result Evaluation Criteria }

There should be no change which might affect the practical display function when the display quality test is conducted under normal operating condition.

## 7. International Standards

### 7-1. Safety

- a) UL 60950, Third Edition, Underwriters Laboratories, Inc., Dated Dec. 11, 2000.  
Standard for Safety of Information Technology Equipment, Including Electrical Business Equipment.
- b) CAN/CSA C22.2, No. 60950, Third Edition, Canadian Standards Association, Dec. 1, 2000.  
Standard for Safety of Information Technology Equipment, Including Electrical Business Equipment.
- c) EN 60950 : 2000, Third Edition  
IEC 60950 : 1999, Third Edition  
European Committee for Electrotechnical Standardization(CENELEC)  
EUROPEAN STANDARD for Safety of Information Technology Equipment Including Electrical Business Equipment.

### 7-2. EMC

- a) ANSI C63.4 "Methods of Measurement of Radio-Noise Emissions from Low-Voltage Electrical and Electrical Equipment in the Range of 9kHz to 40GHz. "American National Standards Institute(ANSI), 1992
- b) C.I.S.P.R "Limits and Methods of Measurement of Radio Interface Characteristics of Information Technology Equipment." International Special Committee on Radio Interference.
- c) EN 55022 "Limits and Methods of Measurement of Radio Interface Characteristics of Information Technology Equipment." European Committee for Electrotechnical Standardization.(CENELEC), 1998 ( Including A1: 2000 )

Product Specification

## 8. Packing

### 8-1. Designation of Lot Mark

a) Lot Mark

A	B	C	D	E	F	G	H	I	J	K	L	M
---	---	---	---	---	---	---	---	---	---	---	---	---

A,B,C : SIZE(INCH)  
E : MONTH

D : YEAR  
F ~ M : SERIAL NO.

Note

1. YEAR

Year	2001	2002	2003	2004	2005	2006	2007	2008	2009	2010
Mark	1	2	3	4	5	6	7	8	9	0

2. MONTH

Month	Jan	Feb	Mar	Apr	May	Jun	Jul	Aug	Sep	Oct	Nov	Dec
Mark	1	2	3	4	5	6	7	8	9	A	B	C

b) Location of Lot Mark

Serial No. is printed on the label. The label is attached to the backside of the LCD module.  
This is subject to change without prior notice.

### 8-2. Packing Form

a) Package quantity in one box : 20 pcs

b) Box Size : 430 X 334 X 287

Product Specification

8-3. Label Description

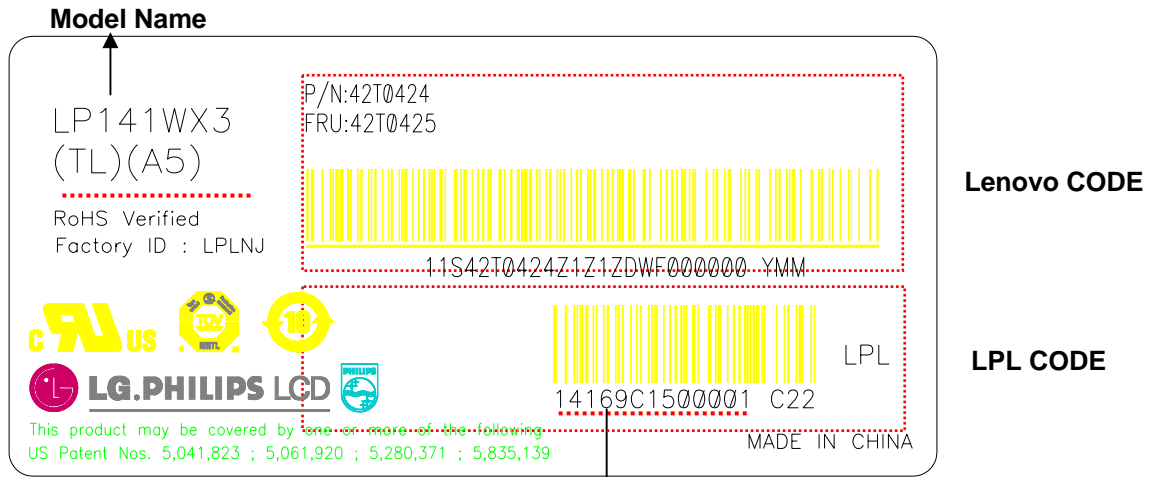

**LPL Code**

**Lot Mark**

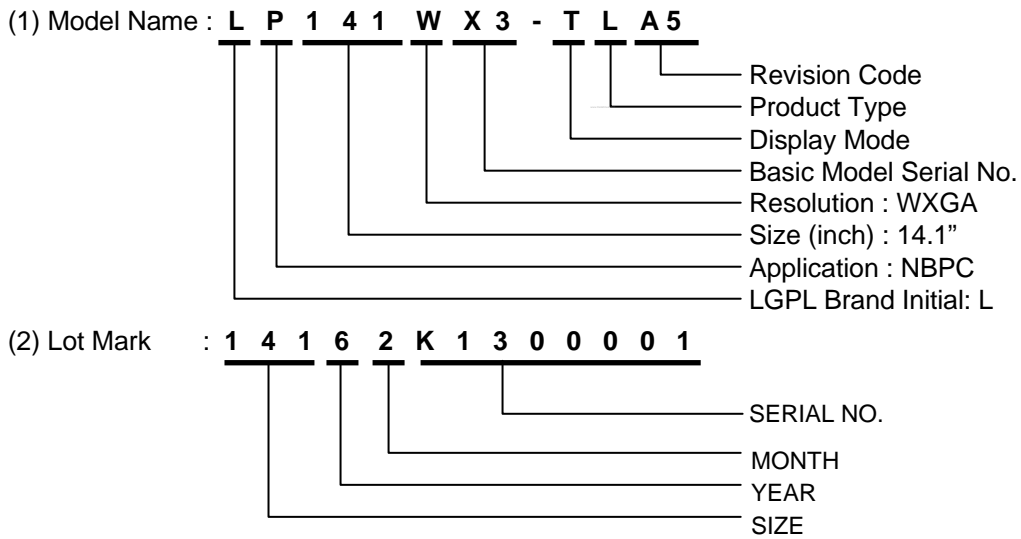

**Lenovo Code**

- 1)P/N : 42T0424
- 2)FRU : 42T0425

## 9. PRECAUTIONS

Please pay attention to the followings when you use this TFT LCD module.

### 9-1. MOUNTING PRECAUTIONS

- (1) You must mount a module using holes arranged in four corners or four sides.
- (2) You should consider the mounting structure so that uneven force (ex. Twisted stress) is not applied to the module. And the case on which a module is mounted should have sufficient strength so that external force is not transmitted directly to the module.
- (3) Please attach the surface transparent protective plate to the surface in order to protect the polarizer. Transparent protective plate should have sufficient strength in order to resist external force.
- (4) You should adopt radiation structure to satisfy the temperature specification.
- (5) Acetic acid type and chlorine type materials for the cover case are not desirable because the former generates corrosive gas of attacking the polarizer at high temperature and the latter causes circuit break by electro-chemical reaction.
- (6) Do not touch, push or rub the exposed polarizers with glass, tweezers or anything harder than HB pencil lead. And please do not rub with dust clothes with chemical treatment. Do not touch the surface of polarizer for bare hand or greasy cloth. (Some cosmetics are detrimental to the polarizer.)
- (7) When the surface becomes dusty, please wipe gently with absorbent cotton or other soft materials like chamois soaks with petroleum benzene. Normal-hexane is recommended for cleaning the adhesives used to attach front / rear polarizers. Do not use acetone, toluene and alcohol because they cause chemical damage to the polarizer.
- (8) Wipe off saliva or water drops as soon as possible. Their long time contact with polarizer causes deformations and color fading.
- (9) Do not open the case because inside circuits do not have sufficient strength.

### 9-2. OPERATING PRECAUTIONS

- (1) The spike noise causes the mis-operation of circuits. It should be lower than following voltage :  
 $V = \pm 200\text{mV}$  (Over and under shoot voltage)
- (2) Response time depends on the temperature. (In lower temperature, it becomes longer.)
- (3) Brightness depends on the temperature. (In lower temperature, it becomes lower.)  
And in lower temperature, response time (required time that brightness is stable after turned on) becomes longer.
- (4) Be careful for condensation at sudden temperature change. Condensation makes damage to polarizer or electrical contacted parts. And after fading condensation, smear or spot will occur.
- (5) When fixed patterns are displayed for a long time, remnant image is likely to occur.
- (6) Module has high frequency circuits. Sufficient suppression to the electromagnetic interference shall be done by system manufacturers. Grounding and shielding methods may be important to minimize the interference.



### 9-3. ELECTROSTATIC DISCHARGE CONTROL

Since a module is composed of electronic circuits, it is not strong to electrostatic discharge. Make certain that treatment persons are connected to ground through wrist band etc. And don't touch interface pin directly.

### 9-4. PRECAUTIONS FOR STRONG LIGHT EXPOSURE

Strong light exposure causes degradation of polarizer and color filter.

### 9-5. STORAGE

When storing modules as spares for a long time, the following precautions are necessary.

- (1) Store them in a dark place. Do not expose the module to sunlight or fluorescent light. Keep the temperature between 5°C and 35°C at normal humidity.
- (2) The polarizer surface should not come in contact with any other object.  
It is recommended that they be stored in the container in which they were shipped.

### 9-6. HANDLING PRECAUTIONS FOR PROTECTION FILM

- (1) When the protection film is peeled off, static electricity is generated between the film and polarizer. This should be peeled off slowly and carefully by people who are electrically grounded and with well ion-blown equipment or in such a condition, etc.
- (2) The protection film is attached to the polarizer with a small amount of glue. If some stress is applied to rub the protection film against the polarizer during the time you peel off the film, the glue is apt to remain on the polarizer.  
Please carefully peel off the protection film without rubbing it against the polarizer.
- (3) When the module with protection film attached is stored for a long time, sometimes there remains a very small amount of glue still on the polarizer after the protection film is peeled off.
- (4) You can remove the glue easily. When the glue remains on the polarizer surface or its vestige is recognized, please wipe them off with absorbent cotton waste or other soft material like chamois soaked with normal-hexane.

Product Specification

LP141WX3-TLA5 EDID Ver. 0.0

2007.06.20

Byte# (decimal)	Byte# (HEX)	Field Name and Comments	Value (HEX)	Value (binary)	Note
0	00	Header	0 0	0000 0000	<b>Header</b>
1	01	Header	F F	1111 1111	
2	02	Header	F F	1111 1111	
3	03	Header	F F	1111 1111	
4	04	Header	F F	1111 1111	
5	05	Header	F F	1111 1111	
6	06	Header	F F	1111 1111	
7	07	Header	0 0	0000 0000	
8	08	ID system Manufacturer Name = LEN	3 0	0011 0000	<b>Vender/ Product ID</b>
9	09	EISA manufacturer code(Compressed ACS II)	A E	1010 1110	
10	0A	ID System - Product code = 3140	3 1	0011 0001	
11	0B	Panel Supplier Reserved - Product code	4 0	0100 0000	
12	0C	LCD Module Serial No. - Preferred but Optional ("0" If not used) = 00	0 0	0000 0000	
13	0D	LCD Module Serial No. - Preferred but Optional ("0" If not used) = 00	0 0	0000 0000	
14	0E	LCD Module Serial No. - Preferred but Optional ("0" If not used) = 00	0 0	0000 0000	
15	0F	LCD Module Serial No. - Preferred but Optional ("0" If not used) = 00	0 0	0000 0000	
16	10	Week of Manufacture = 0 weeks	0 0	0000 0000	<b>EDID Version/ Revision</b>
17	11	Year of Manufacture = 2007 year	1 1	0001 0001	
18	12	EDID Structure version(EDID V1.3) # = 1.3 Version	0 1	0000 0001	
19	13	EDID Revision	0 3	0000 0011	<b>Display Parameter</b>
20	14	Video input Definition (Digital signal)	8 0	1000 0000	
21	15	Max H image size(Rounded cm) = 30 cm	1 E	0001 1110	
22	16	Max V image size(Rounded cm) = 19 cm	1 3	0001 0011	
23	17	Display gamma = (gamma*100)-100 = 2.2	7 8	0111 1000	
24	18	Feature Support (Standby, Suspend, Active Off/Very Low Power, RGB Color display, Timing #1)	E A	1110 1010	<b>Color Characteristic</b>
25	19	Red/Green Low Bits (RxRy/GxGy)	B 3	1011 0011	
26	1A	Blue/White Low Bits (BxBy/WxWy)	8 5	1000 0101	
27	1B	Red X Rx = 0.584	9 5	1001 0101	
28	1C	Red Y Ry = 0.347	5 8	0101 1000	
29	1D	Green X Gx = 0.324	5 3	0101 0011	
30	1E	Green Y Gy = 0.542	8 A	1000 1010	
31	1F	Blue X Bx = 0.158	2 8	0010 1000	
32	20	Blue Y By = 0.145	2 5	0010 0101	<b>Established Timings</b>
33	21	White X Wx = 0.313	5 0	0101 0000	
34	22	White Y Wy = 0.329	5 4	0101 0100	
35	23	Established Timing I = 00h(If not used)	0 0	0000 0000	<b>Standard Timing ID</b>
36	24	Established Timing II = 00h(If not used)	0 0	0000 0000	
37	25	Manufacturer's Timings = 00h(If not used)	0 0	0000 0000	
38	26	Standard Timing Identification ID1 (01h if not used)	0 1	0000 0001	<b>Standard Timing ID</b>
39	27	Standard Timing Identification ID1 (01h if not used)	0 1	0000 0001	
40	28	Standard Timing Identification ID2 (01h if not used)	0 1	0000 0001	
41	29	Standard Timing Identification ID2 (01h if not used)	0 1	0000 0001	
42	2A	Standard Timing Identification ID3 (01h if not used)	0 1	0000 0001	
43	2B	Standard Timing Identification ID3 (01h if not used)	0 1	0000 0001	
44	2C	Standard Timing Identification ID4 (01h if not used)	0 1	0000 0001	
45	2D	Standard Timing Identification ID4 (01h if not used)	0 1	0000 0001	
46	2E	Standard Timing Identification ID5 (01h if not used)	0 1	0000 0001	
47	2F	Standard Timing Identification ID5 (01h if not used)	0 1	0000 0001	
48	30	Standard Timing Identification ID6 (01h if not used)	0 1	0000 0001	
49	31	Standard Timing Identification ID6 (01h if not used)	0 1	0000 0001	
50	32	Standard Timing Identification ID7 (01h if not used)	0 1	0000 0001	
51	33	Standard Timing Identification ID7 (01h if not used)	0 1	0000 0001	
52	34	Standard Timing Identification ID8 (01h if not used)	0 1	0000 0001	
53	35	Standard Timing Identification ID8 (01h if not used)	0 1	0000 0001	

## Product Specification

Byte# (decimal)	Byte# (HEX)	Field Name and Comments	Value (HEX)	Value (binary)	
54	36	Pixel Clock/10,000 (LSB) 69.3 MHz @ 60 Hz	1 2	0001 0010	<b>Timing Descriptor #1</b>
55	37	Pixel Clock/10,000 (MSB)	1 B	0001 1011	
56	38	Horizontal Active 1280 pixels	0 0	0000 0000	
57	39	Horizontal Blanking(Thbp) 125 pixels	7 D	0111 1101	
58	3A	Horizontal Active / Horizontal Blanking(Thbp)	5 0	0101 0000	
59	3B	Vertical Active 800 lines	2 0	0010 0000	
60	3C	Vertical Blanking (Tvbp) 22 lines	1 6	0001 0110	
61	3D	Vertical Active : Vertical Blanking (Tvbp)	3 0	0011 0000	
62	3E	Horizontal Sync. Offset (Thfp) 48 pixels	3 0	0011 0000	
63	3F	Horizontal Sync Pulse Width 32 pixels	2 0	0010 0000	
64	40	Vertical Sync Offset(Tvbp) : Sync Width 3 lines : 6 lines	3 6	0011 0110	
65	41	Horizontal Vertical Sync Offset/Width upper 2bits	0 0	0000 0000	
66	42	Horizontal Image Size 304 mm	3 0	0011 0000	
67	43	Vertical Image Size 190 mm	B E	1011 1110	
68	44	Horizontal Image Size / Vertical Image Size	1 0	0001 0000	
69	45	Horizontal Border = 0 (Zero for Notebook LCD)	0 0	0000 0000	
70	46	Vertical Border = 0 (Zero for Notebook LCD)	0 0	0000 0000	
71	47	Non-interlaced, Normal, no stereo, separate sync, H/V pol negatives, DE only note : LSB is set to '1' if panel is DE-timing only. H/V can be ignored.	1 8	0001 1000	
72	48	Pixel Clock/10,000 (LSB) 57.75 MHz @ 50 Hz	8 F	1000 1111	<b>Timing Description #2</b>
73	49	Pixel Clock/10,000 (MSB)	1 6	0001 0110	
74	4A	Horizontal Active 1280 pixels	0 0	0000 0000	
75	4B	Horizontal Blanking(Thbp) 125 pixels	7 D	0111 1101	
76	4C	Horizontal Active / Horizontal Blanking(Thbp)	5 0	0101 0000	
77	4D	Vertical Active 800 lines	2 0	0010 0000	
78	4E	Vertical Blanking (Tvbp) 22 lines	1 6	0001 0110	
79	4F	Vertical Active : Vertical Blanking (Tvbp)	3 0	0011 0000	
80	50	Horizontal Sync. Offset (Thfp) 48 pixels	3 0	0011 0000	
81	51	Horizontal Sync Pulse Width 32 pixels	2 0	0010 0000	
82	52	Vertical Sync Offset(Tvbp) : Sync Width 3 lines : 6 lines	3 6	0011 0110	
83	53	Horizontal Vertical Sync Offset/Width upper 2bits	0 0	0000 0000	
84	54	Horizontal Image Size 304 mm	3 0	0011 0000	
85	55	Vertical Image Size 190 mm	B E	1011 1110	
86	56	Horizontal Image Size / Vertical Image Size	1 0	0001 0000	
87	57	Horizontal Border = 0 (Zero for Notebook LCD)	0 0	0000 0000	
88	58	Vertical Border = 0 (Zero for Notebook LCD)	0 0	0000 0000	
89	59	Non-interlaced, Normal, no stereo, separate sync, H/V pol negatives, DE only note : LSB is set to '1' if panel is DE-timing only. H/V can be ignored.	1 8	0001 1000	
90	5A	Flag	0 0	0000 0000	<b>Timing Description #3</b>
91	5B	Flag	0 0	0000 0000	
92	5C	Flag	0 0	0000 0000	
93	5D	Data Type Tag (Descriptor Defined by manufacturer )	0 F	0000 1111	
94	5E	Flag	0 0	0000 0000	
95	5F	(Horizontal active pixel /8)-31 129	8 1	1000 0001	
96	60	Image Aspect Ratio(15:9) 16 : 10	0 A	0000 1010	
97	61	Low Refresh Rate #1(50Hz) 50 Hz	3 2	0011 0010	
98	62	(Horizontal active pixel /8)-31 129	8 1	1000 0001	
99	63	Image Aspect Ratio(16:10) 16 : 10	0 A	0000 1010	
100	64	Low Refresh Rate #2(40Hz) 40 Hz	2 8	0010 1000	
101	65	Brightness(1/10nit) 185 nit	1 2	0001 0010	
102	66	Feature flag(TN mode)	0 1	0000 0001	
103	67	Reserved 00h	0 0	0000 0000	
104	68	EISA manufacturer code(3 Character ID) LPL	3 2	0011 0010	
105	69	Compressed ASCII	0 C	0000 1100	
106	6A	Panel Supplier Reserved - Product code 010E	0 1	0000 0001	
107	6B	(Hex, LSB first)	0 E	0000 1110	

Product Specification

Byte# (decimal)	Byte# (HEX)	Field Name and Comments	Value (HEX)	Value (binary)	
108	6C	Flag	0 0	0000 0000	<b>Timing Description #4</b>
109	6D	Flag	0 0	0000 0000	
110	6E	Flag	0 0	0000 0000	
111	6F	Data Type Tag (ASCII String )	F E	1111 1110	
112	70	Flag	0 0	0000 0000	
113	71	Panel supplier P/N #1 = L	4 C	0100 1100	
114	72	Panel supplier P/N #2 = P	5 0	0101 0000	
115	73	Panel supplier P/N #3 = 1	3 1	0011 0001	
116	74	Panel supplier P/N #4 = 4	3 4	0011 0100	
117	75	Panel supplier P/N #5 = 1	3 1	0011 0001	
118	76	Panel supplier P/N #6 = W	5 7	0101 0111	
119	77	Panel supplier P/N #7 = X	5 8	0101 1000	
120	78	Panel supplier P/N #8 = 3	3 3	0011 0011	
121	79	Panel supplier P/N #9 = -	2 D	0010 1101	
122	7A	Panel supplier P/N #10 = T	5 4	0101 0100	
123	7B	Panel supplier P/N #11 = L	4 C	0100 1100	
124	7C	Panel supplier P/N #12 = A	4 1	0100 0001	
125	7D	Panel supplier P/N #13 = 5	3 5	0011 0101	
126	7E	Extension flag = 00	0 0	0000 0000	<b>Extension Flag</b>
127	7F	Checksum	<b>E 8</b>	1110 1000	<b>Checksum</b>