

# SPECIFICATION FOR APPROVAL

- ( ) Preliminary Specification  
( ) Final Specification

Title	15.0" SXGA+ TFT LCD
-------	---------------------

BUYER	
MODEL	

SUPPLIER	LG.Philips LCD Co., Ltd.
*MODEL	LP150E06
Suffix	A3K2

\*When you obtain standard approval,  
—please use the above model name without suffix

SIGNATURE	DATE
/	_____
/	_____
/	_____

Please return 1 copy for your confirmation with your signature and comments.

APPROVED BY	Signature
J. H. Lee / S.Manager	
REVIEWED BY K. K. Jang / Manager	
PREPARED BY N.J. Sung / Engineer	

**Product Engineering Dept.  
LG. Philips LCD Co., Ltd**

## Product Specification

Contents

No	ITEM	Page
	COVER	1,2
	CONTENTS	3
	RECORD OF REVISIONS	4
1	GENERAL DESCRIPTION	5
2	ABSOLUTE MAXIMUM RATINGS	6
3	ELECTRICAL SPECIFICATIONS	7
3-1	ELECTRICAL CHARACTERISTICS	6
3-2	INTERFACE CONNECTIONS	9
3-3	SIGNAL TIMING SPECIFICATIONS	10
3-4	SIGNAL TIMING WAVEFORMS	10
3-5	COLOR INPUT DATA REFERENCE	11
3-6	POWER SEQUENCE	12
4	OPTICAL SPECIFICATIONS	13
5	MECHANICAL CHARACTERISTICS	17
6	RELIABILITY	21
7	INTERNATIONAL STANDARDS	22
7-1	SAFETY	22
7-2	EMC	22
8	PACKING	23
8-1	DESIGNATION OF LOT MARK	23
8-2	PACKING FORM	23
9	PRECAUTIONS	24
9-1	MOUNTING PRECAUTIONS	24
9-2	OPERATING PRECAUTIONS	24
9-3	ELECTROSTATIC DISCHARGE CONTROL	25
9-4	PRECAUTIONS FOR STRONG LIGHT EXPOSURE	25
9-5	STORAGE	25
9-6	HANDLING PRECAUTIONS FOR PROTECTION FILM	25
A	APPENDIX. Enhanced Extended Display Identification Data	26



Product Specification

### 1. General Description

The LP150E06 is a Color Active Matrix Liquid Crystal Display with an integral Cold Cathode Fluorescent Lamp(CCFL) backlight system. The matrix employs a-Si Thin Film Transistor as the active element. It is a transmissive type display operating in the normally white mode. This TFT-LCD has 15.0 inches diagonally measured active display area with SXGA+ resolution(1050 vertical by 1400 horizontal pixel array) Each pixel is divided into Red, Green and Blue sub-pixels or dots which are arranged in vertical stripes. Gray scale or the brightness of the sub-pixel color is determined with a 6-bit gray scale signal for each dot, thus, presenting a palette of more than 262,144 colors.

The LP150E06 has been designed to apply the interface method that enables low power, high speed, low EMI.

The LP150E06 is intended to support applications where thin thickness, low power are critical factors and graphic display are important. In combination with the vertical arrangement of the sub-pixels, the LP150E06 characteristics provide an excellent flat display for office automation products such as Notebook PC.

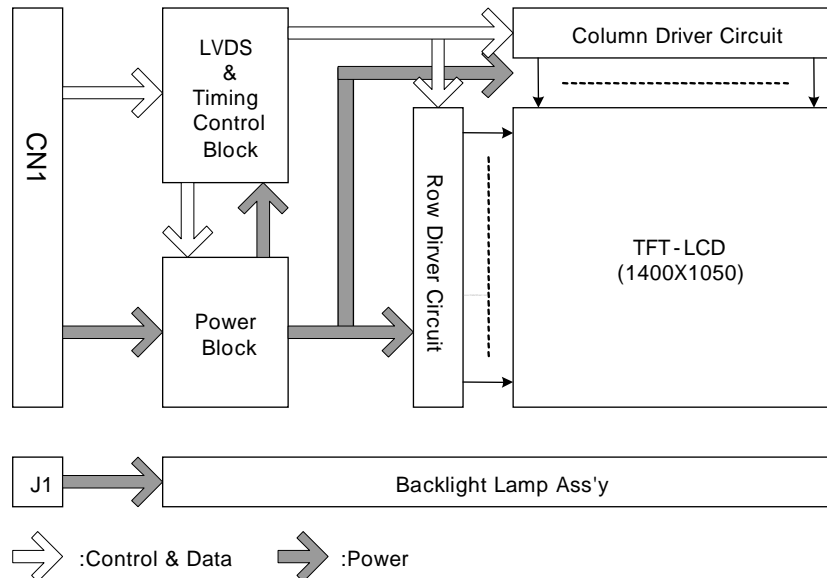

### General Features

Active Screen Size	15.0 inches(38.1cm) diagonal
Outline Dimension	317.2(H) x 241.4(V), 5.7(D) mm(Typ.)
Pixel Pitch	0.2175 mm x 0.2175 mm
Pixel Format	1400 horiz. By 1050 vert. Pixels RGB strip arrangement
Color Depth	6-bit, 262,144 colors
Luminance, White	185 cd/m <sup>2</sup> (Typ.), 5p average
Power Consumption	Total 4.8 W (Typ.) ( 1.3W Logic / 3.5W Backlight )
Weight	520g(Typ.), 535g(Max.)
Display Operating Mode	Transmissive mode, normally white
Surface Treatment	Hard coating(3H) Anti-glare treatment of the front polarizer

Product Specification

2. Absolute Maximum Ratings

The following are maximum values which, if exceeded, may cause faulty operation or damage to the unit.

Table 1. ABSOLUTE MAXIMUM RATINGS

Parameter	Symbol	Values		Units	Notes
		Min	Max		
Power Input Voltage-ON	VCC	2.7	4.0	Vdc	at 25 ± 5°C
Power Input Voltage-OFF	GND	-0.3	0.3	Vdc	at 25 ± 5°C
Operating Temperature	TOP	0	50	°C	1
Storage Temperature	TST	-20	60	°C	1
Operating Ambient Humidity	HOP	10	90	%RH	1
Storage Humidity	HST	10	90	%RH	1
Electrostatic Durability (ESD)	VESD	± 8.0		kV	2

Note : 1. Temperature and relative humidity range are shown in the figure below.

Wet bulb temperature should be 39°C Max, and no condensation of water.

2. Condition 1) Non-operation, 150pF-330 , 25 , 40~60%RH
- 2) I/F Connector pins are subjected.
- 3) The surface of Metal bezel and LCD are subjected except interface connector.(LCD side)
- 4) Discharge interval time 1sec, 10 times each place

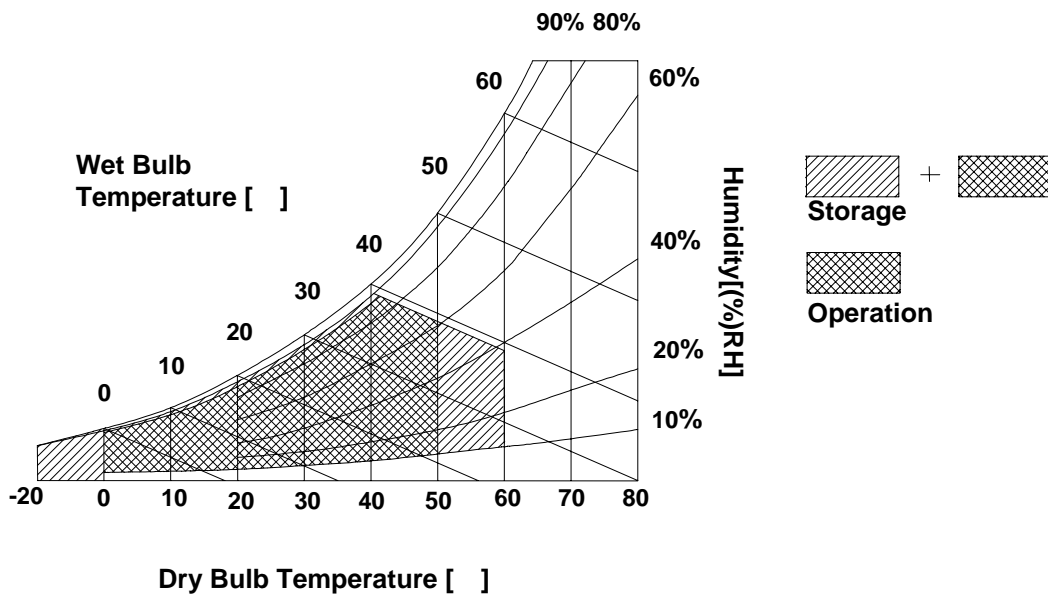

Product Specification

### 3. Electrical Specifications

#### 3-1. Electrical Characteristics

The LP150E06 requires two power inputs. One is employed to power the LCD electronics and to drive the TFT array and liquid crystal. The second input which powers the CCFL, is typically generated by an inverter. The inverter is an external unit to the LCD.

**Table 2. ELECTRICAL CHARACTERISTICS**

Parameter	Symbol	Values			Unit	Notes
		Min	Typ	Max		
<b>MODULE :</b>						
Power Supply Input Voltage	VCC	3.0	3.3	3.6	Vdc	
Power Supply Input Current	I <sub>CC</sub>	-	385	443	mA	1
Power Consumption	Pc	-	1.30	1.60	Watt	1
Differential Impedance	Zm	90	100	110	ohm	2
<b>LAMP :</b>						
Operating Voltage	V <sub>BL</sub>	660	705	870	V <sub>RMS</sub>	3
Operating Current	I <sub>BL</sub>	2.0	5.0	6.3	mA <sub>RMS</sub>	
Established Starting Voltage	V <sub>s</sub>					4
at 25 °C		-	-	1165	V <sub>RMS</sub>	
at 0 °C		-	-	1400	V <sub>RMS</sub>	
Operating Frequency	f <sub>BL</sub>	50	65	80	kHz	5
Discharge Stabilization Time	T <sub>s</sub>	-	-	3	Min	6
Power Consumption	P <sub>BL</sub>	-	3.50	4.00	Watt	7
Life Time		10,000	-	-	Hrs	8

Note : The design of the inverter must have specifications for the lamp in LCD Assembly.

The performance of the Lamp in LCM, for example life time or brightness, is extremely influenced by the characteristics of the DC-AC inverter. So all the parameters of an inverter should be carefully designed so as not to produce too much leakage current from high-voltage output of the inverter. When you design or order the inverter, please make sure unwanted lighting caused by the mismatch of the lamp and the inverter(no lighting, flicker, etc) never occurs. When you confirm it, the LCD – Assembly should be operated in the same condition as installed in you instrument.

1. The specified current and power consumption are under the VCC=3.3V, 25°C, f<sub>v</sub>=60Hz condition whereas Mosaic pattern is displayed and f<sub>v</sub> is the frame frequency.
2. This impedance value is needed to proper display and measured from LVDS T<sub>x</sub> to the mating connector.
3. The variance of the voltage is ± 10%.
- 4. FOS, and reliability test condition is at 6.0mA**
5. The voltage above V<sub>s</sub> should be applied to the lamps for more than 1 second for start-up. Otherwise, the lamps may not be turned on. The used lamp current is the lamp typical current.

Product Specification

6. The output of the inverter must have symmetrical(negative and positive) voltage waveform and symmetrical current waveform.(Unsymmetrical ratio is less than 10%) Please do not use the inverter which has unsymmetrical voltage and unsymmetrical current and spike wave.  
Lamp frequency may produce interface with horizontal synchronous frequency and as a result this may cause beat on the display. Therefore lamp frequency shall be as away possible from the horizontal synchronous frequency and from its harmonics in order to prevent interference.
7. Let's define the brightness of the lamp after being lighted for 5 minutes as 100%.  
 $T_s$  is the time required for the brightness of the center of the lamp to be not less than 95%.
8. The lamp power consumption shown above does not include loss of external inverter.  
The used lamp current is the lamp typical current.
9. The life is determined as the time at which brightness of the lamp is 50% compared to that of initial value at the maximum lamp current( $6.0m^{A_{RMS}}$ ) on condition of continuous operating at  $25 \pm 2^{\circ}C$
10. Requirements for a system inverter design, which is intended to have a better display performance, a better power efficiency and a more reliable lamp, are following.  
It shall help increase the lamp lifetime and reduce leakage current.
  - a. The asymmetry rate of the inverter waveform should be less than 10%.
  - b. The distortion rate of the waveform should be within  $\sqrt{2} \pm 10\%$ .

\* Inverter output waveform had better be more similar to ideal sine wave.

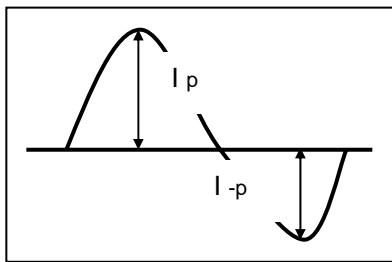

\* Asymmetry rate:

$$|I_p - I_{-p}| / I_{rms} * 100\%$$

\* Distortion rate

$$I_p \text{ (or } I_{-p}) / I_{rms}$$

Do not attach a conducting tape to lamp connecting wire.

If the lamp wire attach to a conducting tape, TFT-LCD Module has a low luminance and the inverter has abnormal action. Because leakage current is occurred between lamp wire and conducting tape.

Product Specification

### 3-2. Interface Connections

The interface connections are compatible with **ISP (Industry Standard Panels) 15.0" Mounting and Top Level Interface Requirements (Version2, June,2000)** defined by **SPWG (Standard Panels Working Group)**. This LCD employs two interface connections, a 30 pin connector is used for the module electronics and the other connector is used for the integral backlight system.

The electronics interface connector is a model GT101-30S-HR11 manufactured by LG Cable. The pin configuration for the connector is shown in the table below.

**Table 3. MODULE CONNECTOR PIN CONFIGURATION (CN1)**

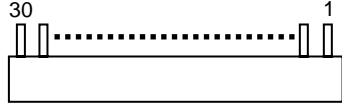
Pin	Symbol	Description	Notes
1	VSS	Ground	[LVDS Transmitter] Thine, THC63LVDF823A or equivalent  [LVDS Receiver] Thine, THC63LVDF824A  [Connector] LCD : GT101-30S-HR11, LG Cable * <b>JAE FI-XB30Sx-HFxx or JAE FI-XB30S-HF or equivalent.</b> Matching : JAE FI-X30M or equivalent  [Connector pin arrangement]  LCD rear view
2	VCC	Power Supply, 3.3V Typ.	
3	VCC	Power Supply, 3.3V Typ.	
4	VEDID	DDC 3.3V power	
5	NC	No Connection	
6	CLKEDID	DDC Clock	
7	DATAEDID	DDC Data	
8	Odd_R <sub>IN</sub> 0-	-LVDS differential data (odd pixels R0-R5, G0)	
9	Odd_R <sub>IN</sub> 0+	+LVDS differential data (odd pixels R0-R5, G0)	
10	VSS	Ground	
11	Odd_R <sub>IN</sub> 1-	-LVDS differential data (odd pixels G1-G5, B0-B1)	
12	Odd_R <sub>IN</sub> 1+	+LVDS differential data (odd pixels G1-G5, B0-B1)	
13	VSS	Ground	
14	Odd_R <sub>IN</sub> 2-	-LVDS differential data (odd pixels B2-B5, HS, VS, DE)	
15	Odd_R <sub>IN</sub> 2+	+LVDS differential data (odd pixels B2-B5, HS, VS, DE)	
16	VSS	Ground	
17	Odd_Clk <sub>IN</sub> -	-LVDS differential clock (odd pixels)	
18	Odd_Clk <sub>IN</sub> +	+LVDS differential clock(odd pixels)	
19	VSS	Ground	
20	Even_R <sub>IN</sub> 0-	-LVDS differential data (even pixels R0-R5, G0)	
21	Even_R <sub>IN</sub> 0+	+LVDS differential data (even pixels R0-R5, G0)	
22	VSS	Ground	
23	Even_R <sub>IN</sub> 1-	-LVDS differential data (even pixels G1-G5, B0-B1)	
24	Even_R <sub>IN</sub> 1+	+LVDS differential data (even pixels G1-G5, B0-B1)	
25	VSS	Ground	
26	Even_R <sub>IN</sub> 2-	-LVDS differential data (even pixels B2-B5, HS, VS, DE)	
27	Even_R <sub>IN</sub> 2+	+LVDS differential data (even pixels B2-B5, HS, VS, DE)	
28	VSS	Ground	
29	Even_Clk <sub>IN</sub> -	-LVDS differential clock (even pixels)	
30	Even_Clk <sub>IN</sub> +	+LVDS differential clock (even pixels)	

Note: All GND(ground) pins should be connected together and to GND which should also be connected to the LCD's metal frame. All VCC (power input) pins should be connected together.

The backlight interface connector is a model BHSR-02VS-1, manufactured by JST or Compatible.

The mating connector part number is SM02B-BHSS-1 or equivalent.

**Table 4. BACKLIGHT CONNECTOR PIN CONFIGURATION (J1)**

Pin	Symbol	Description	Notes
1	HV	Power supply for lamp (High voltage side)	1
2	LV	Power supply for lamp (Low voltage side)	1

Notes : 1. The high voltage side terminal is colored pink and the low voltage side terminal is yellow



### 3-3. Signal Timing Specifications

This is the signal timing required at the input of the User connector. All of the interface signal timing should be satisfied with the following specifications and specifications of LVDS Tx/Rx for its proper operation.

**Table 5. TIMING TABLE**

ITEM	Symbol	Min	Typ	Max	Unit	Note
DCLK	Frequency	fCLK	53.5	54	54.5	MHz
Hsync	Period	tHP	732	800	848	tCLK
	Width	tWH	8	-	-	
Vsync	Period	tVP	1060	1125	1150	tHP
	Width	tWV	2	-	-	
Data Enable	Horizontal back porch	tHBP	8	-	-	tCLK
	Horizontal front porch	tHFP	8	-	-	
	Vertical back porch	tVBP	3	-	-	tHP
	Vertical front porch	tVFP	2	-	-	

DCLK : Dual Port Operating

### 3-4. Signal Timing Waveforms

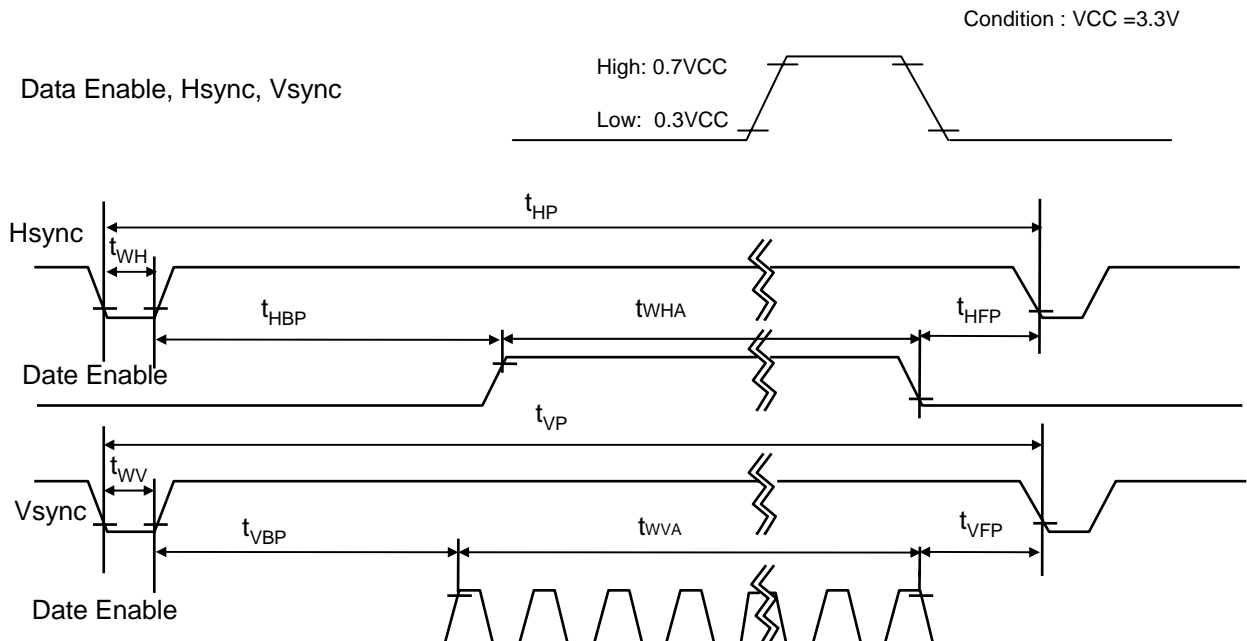

Product Specification

### 3-5. Color Input Data Reference

The brightness of each primary color (red, green and blue) is based on the 6-bit gray scale data input for the color ; the higher the binary input, the brighter the color. The table below provides a reference for color versus data input.

**Table 6. COLOR DATA REFERENCE**

Color		Input Color Data																	
		RED						GREEN						BLUE					
		MSB				LSB		MSB				LSB		MSB		LSB			
		R 5	R 4	R 3	R 2	R 1	R 0	G 5	G 4	G 3	G 2	G 1	G 0	B 5	B 4	B 3	B 2	B 1	B 0
Basic Color	Black	0	0	0	0	0	0	0	0	0	0	0	0	0	0	0	0	0	0
	Red	1	1	1	1	1	1	0	0	0	0	0	0	0	0	0	0	0	0
	Green	0	0	0	0	0	0	1	1	1	1	1	1	0	0	0	0	0	0
	Blue	0	0	0	0	0	0	0	0	0	0	0	0	1	1	1	1	1	1
	Cyan	0	0	0	0	0	0	1	1	1	1	1	1	1	1	1	1	1	1
	Magenta	1	1	1	1	1	1	0	0	0	0	0	0	1	1	1	1	1	1
	Yellow	1	1	1	1	1	1	1	1	1	1	1	1	0	0	0	0	0	0
	White	1	1	1	1	1	1	1	1	1	1	1	1	1	1	1	1	1	1
RED	RED (00)	0	0	0	0	0	0	0	0	0	0	0	0	0	0	0	0	0	0
	RED (01)	0	0	0	0	0	1	0	0	0	0	0	0	0	0	0	0	0	0
	...	...						...						...					
	RED (62)	1	1	1	1	1	0	0	0	0	0	0	0	0	0	0	0	0	0
	RED (63)	1	1	1	1	1	1	0	0	0	0	0	0	0	0	0	0	0	0
GREEN	GREEN (00)	0	0	0	0	0	0	0	0	0	0	0	0	0	0	0	0	0	0
	GREEN (01)	0	0	0	0	0	0	0	0	0	0	0	1	0	0	0	0	0	0
	...	...						...						...					
	GREEN (62)	0	0	0	0	0	0	1	1	1	1	1	0	0	0	0	0	0	0
	GREEN (63)	0	0	0	0	0	0	1	1	1	1	1	1	0	0	0	0	0	0
BLUE	BLUE (00)	0	0	0	0	0	0	0	0	0	0	0	0	0	0	0	0	0	0
	BLUE (01)	0	0	0	0	0	0	0	0	0	0	0	0	0	0	0	0	0	1
	...	...						...						...					
	BLUE (62)	0	0	0	0	0	0	0	0	0	0	0	0	1	1	1	1	1	0
	BLUE (63)	0	0	0	0	0	0	0	0	0	0	0	0	1	1	1	1	1	1

Product Specification

### 3-6. Power Sequence

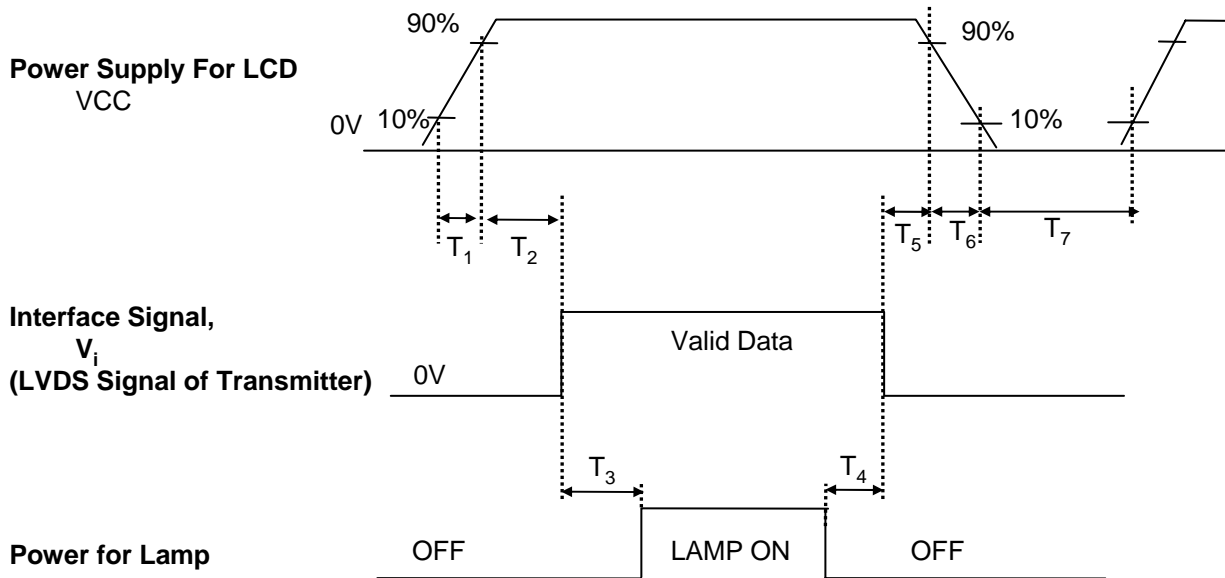

**Table 7. POWER SEQUENCE TABLE**

Parameter	Value			Units
	Min.	Typ.	Max.	
T <sub>1</sub>	-	-	10	(ms)
T <sub>2</sub>	0	-	50	(ms)
T <sub>3</sub>	200	-	-	(ms)
T <sub>4</sub>	200	-	-	(ms)
T <sub>5</sub>	0	-	50	(ms)
T <sub>6</sub>	0	-	100	(ms)
T <sub>7</sub>	400	-	-	(ms)

- Notes :
1. Please avoid floating state of interface signal at invalid period.
  2. When the interface signal is invalid, be sure to pull down the power supply for LCD VCC to 0V.
  3. Lamp power must be turn on after power supply for LCD and interface signal are valid.

Product Specification

4. Optical Specification

Optical characteristics are determined after the unit has been 'ON' and stable for approximately 30 minutes in a dark environment at 25°C. The values specified are at an approximate distance 50cm from the LCD surface at a viewing angle of  $\Phi$  and  $\Theta$  equal to 0°.

FIG. 1 presents additional information concerning the measurement equipment and method.

FIG. 1 Optical Characteristic Measurement Equipment and Method

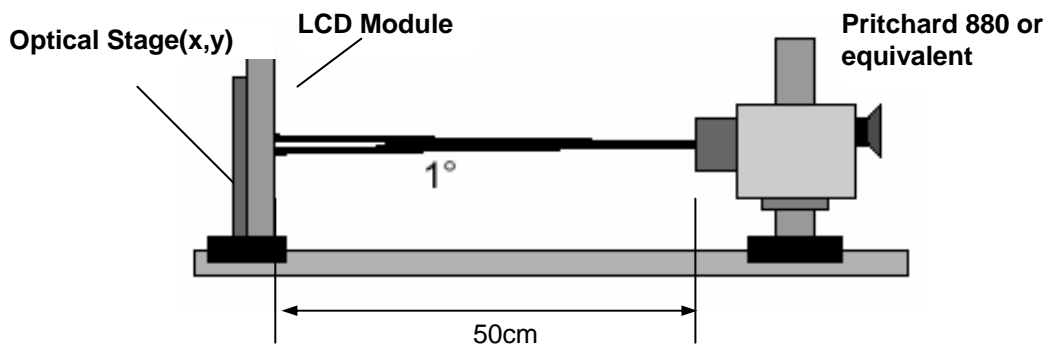

Table 8. OPTICAL CHARACTERISTICS

Ta=25°C, VCC=3.3V, fv=60Hz  
Dclk= 54MHz, IBL= 6.0mA

Parameter	Symbol	Values			Units	Notes
		Min	Typ	MAx		
Contrast Ratio	CR	150	300	-		1
Surface Luminance, white (5P, Ave)	L <sub>WH</sub>	150	185	-	cd/m <sup>2</sup>	2
Luminance Variation	$\delta_{\text{WHITE}}$	-	-	1.85		3
Response Time						4
Rise Time	T <sub>R</sub>	-	10	20	ms	
Decay Time	T <sub>D</sub>	-	20	30	ms	
Color Coordinates						PR650 or equivalent
RED	RX	0.560	0.590	0.620		
GREEN	GX	0.290	0.320	0.350		
BLUE	BX	0.125	0.155	0.185		
WHITE	WX	0.283	0.313	0.343		
	WY	0.299	0.329	0.359		
Viewing Angle						5
x axis, right( $\Phi=0^\circ$ )	$\Theta_r$	55	60	-	degree	
x axis, left ( $\Phi=180^\circ$ )	$\Theta_l$	55	60	-	degree	
y axis, up ( $\Phi=90^\circ$ )	$\Theta_u$	40	45	-	degree	
y axis, down ( $\Phi=270^\circ$ )	$\Theta_d$	40	45	-	degree	
Gray Scale						6

Product Specification

Notes 1. Contrast Ratio(CR) is defined mathematically as :

$$\text{Contrast Ratio} = \frac{\text{Surface Luminance with all white pixels}}{\text{Surface Luminance with all black pixels}}$$

2. Surface luminance is the average of 5 points across the LCD surface 50cm from the surface with all pixels displaying white. For more information see FIG 1., When  $I_{BL}=6.0\text{mA}$ .

3. The variation in surface luminance , The Panel total variation ( $\delta_{\text{WHITE}}$ ) is determined by measuring  $L_{ON}$  at each test position 1 through 13, and then dividing the maximum  $L_{ON}$  of 13 points luminance by minimum  $L_{ON}$  of 13 points luminance. For more information see FIG 2.

$$\delta_{\text{WHITE}} = \text{Maximum}(L_1, L_2, \dots L_{13}) / \text{Minimum}(L_1, L_2, \dots L_{13})$$

4. Response time is the time required for the display to transition from white to black(RiseTime,  $Tr_R$ ) and from black to white(Decay Time,  $Tr_D$ ). For additional information see FIG 3.

5. Viewing angle is the angle at which the contrast ratio is greater than 10. The angles are determined for the horizontal or x axis and the vertical or y axis with respect to the z axis which is normal to the LCD surface. For more information see FIG 4.

6. Gray scale specification

\*  $f_V=60\text{Hz}$

Gray Level	Luminance [%] (Typ)
L0	0.33
L7	0.83
L15	3.93
L23	9.50
L31	19.0
L39	31.0
L47	48.0
L55	75.0
L63	100.0

Product Specification

**FIG. 2 Luminance**

<measuring point for surface luminance & measuring point for luminance variation>

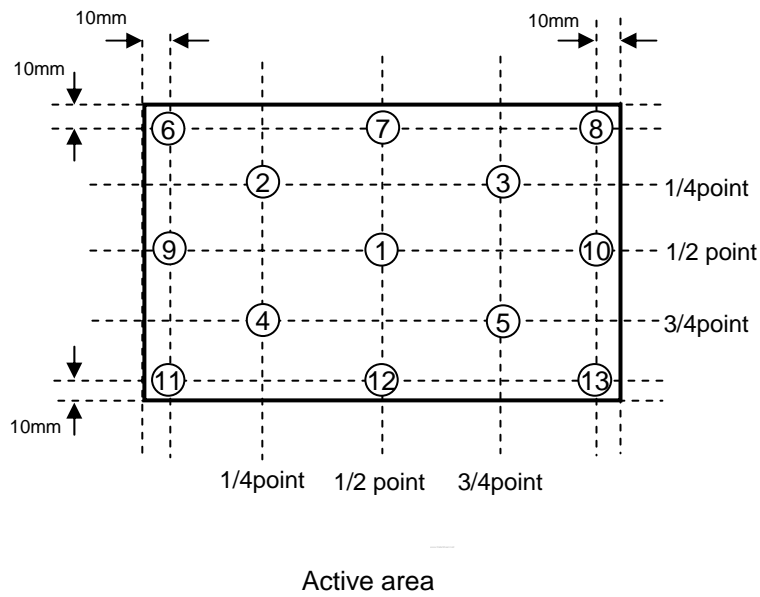

**FIG. 3 Response Time**

The response time is defined as the following figure and shall be measured by switching the input signal for "black" and "white".

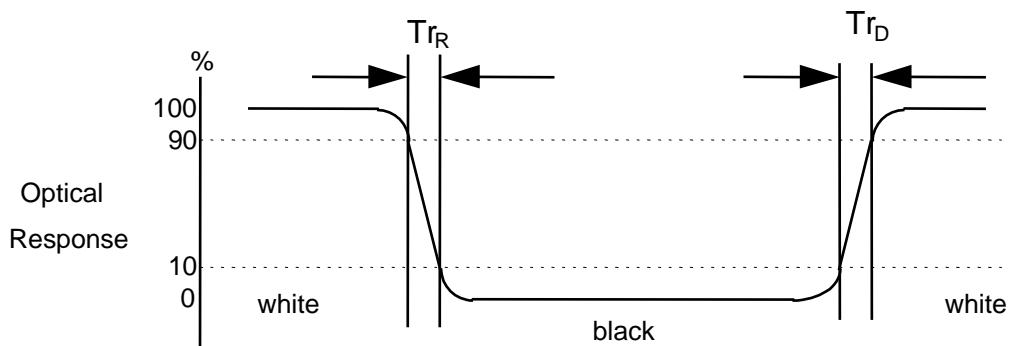

Product Specification

**FIG. 4 Viewing angle**

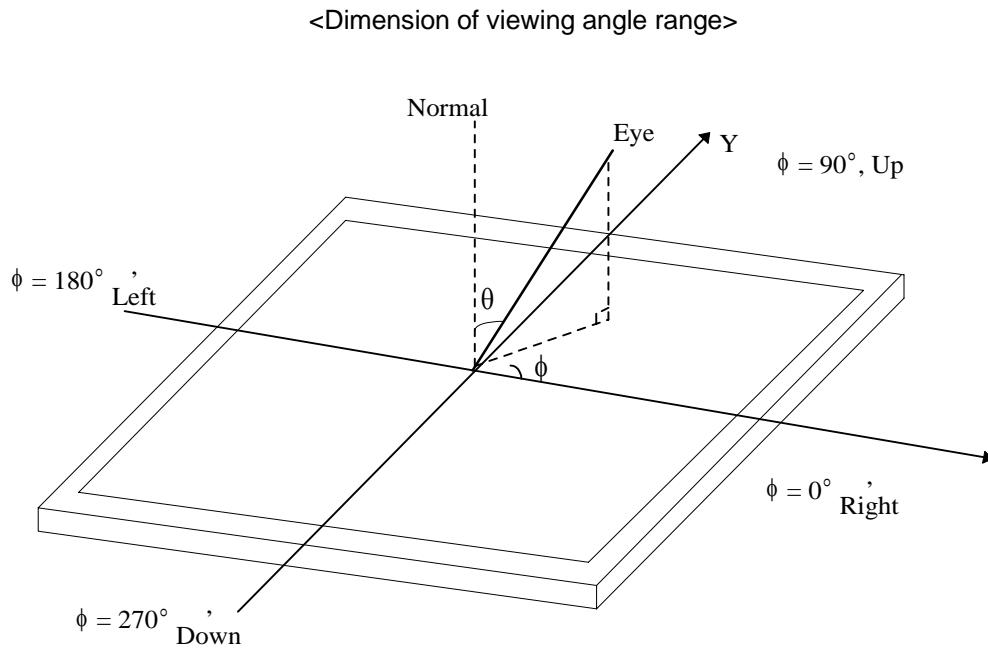

## Product Specification

## 5. Mechanical Characteristics

The contents provide general mechanical characteristics for the model LP150E06. In addition the figures in the next page are detailed mechanical drawing of the LCD.

Outline Dimension	Horizontal	317.2 ± 0.5mm
	Vertical	241.4 ± 0.5mm
	Depth	5.7 mm(Typ.) 6.0mm(Max.)
Bezel Area	Horizontal	307.5 ± 0.5mm
	Vertical	231.4 ± 0.5mm
Active Display Area	Horizontal	304.500 mm
	Vertical	228.375 mm
Weight	520g(Typ.), 535g(Max.)	
Surface Treatment	Hard coating(3H) Anti-glare treatment of the front polarizer (Haze 25%)	



**Product Specification**

<FRONT VIEW>

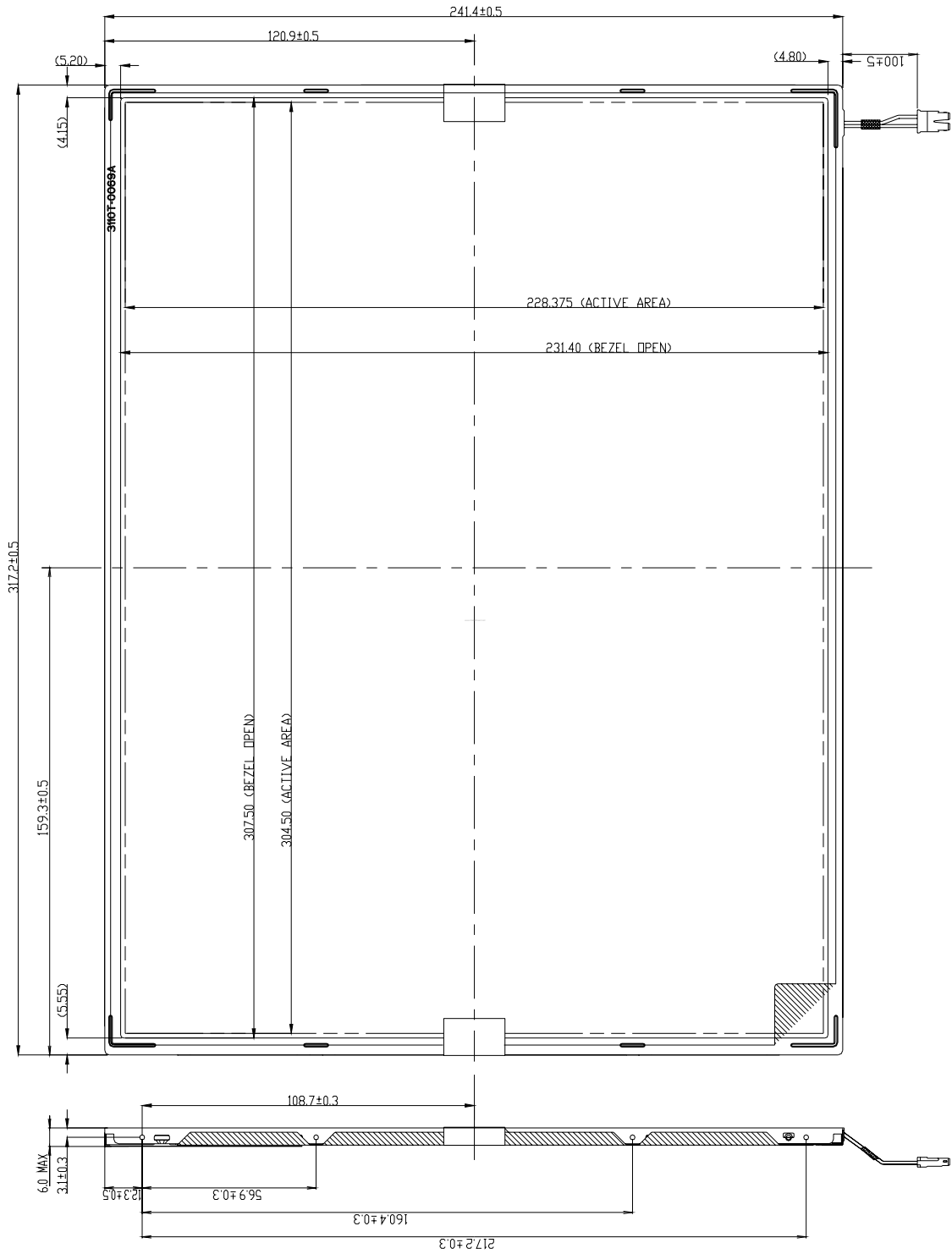

**Product Specification**

<REAR VIEW>

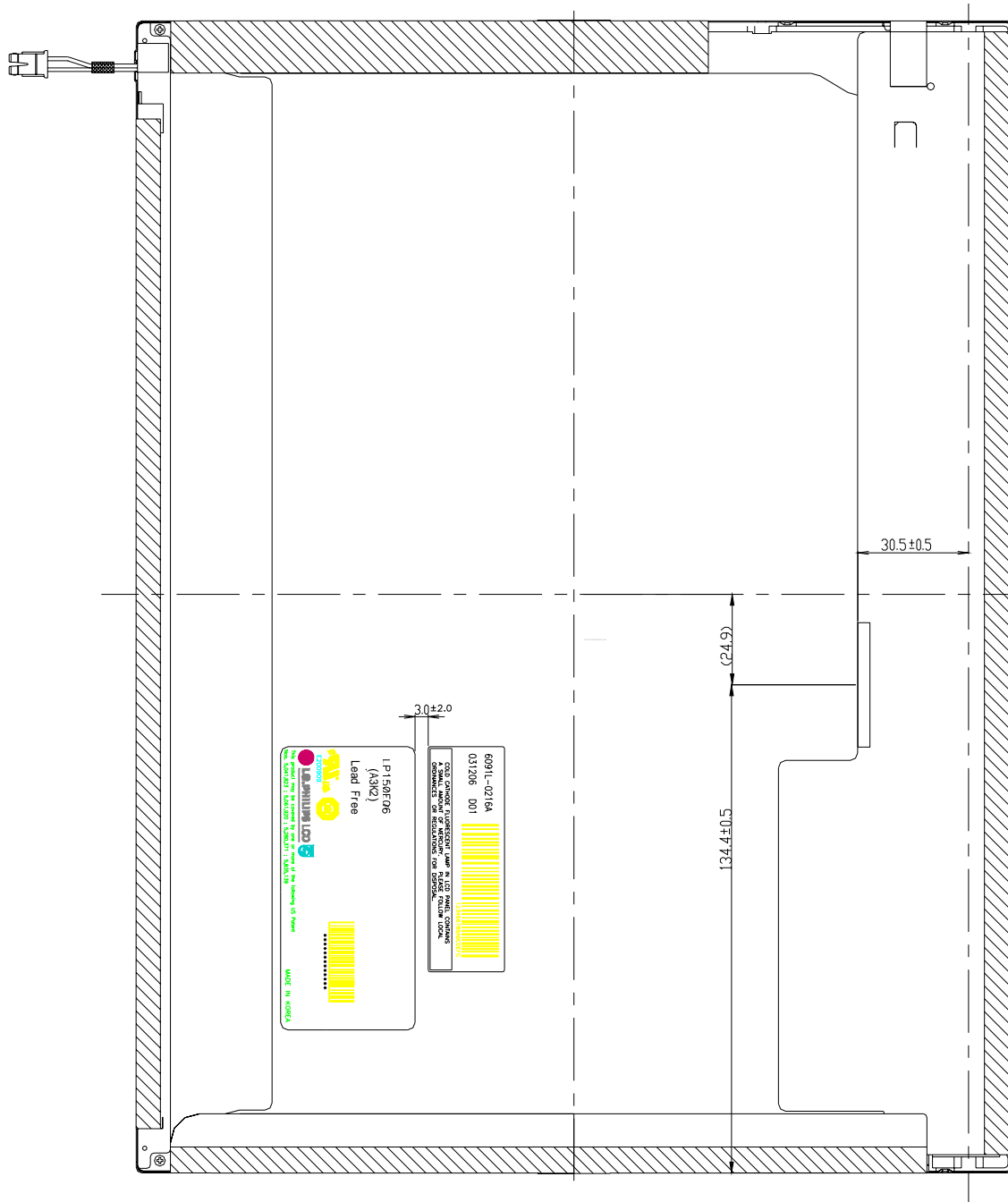

Product Specification

[ DETAIL DESCRIPTION OF SIDE MOUNTING SCREW ]

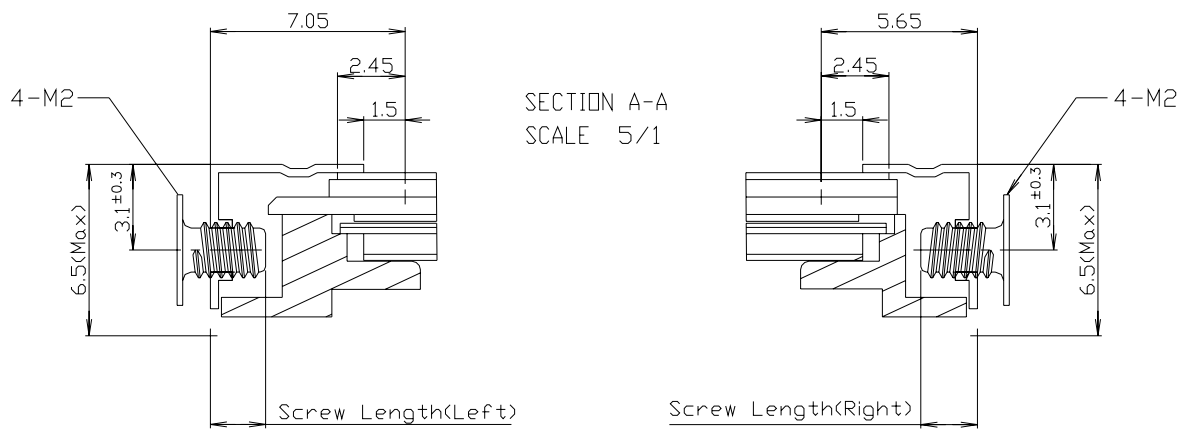

- \* Screw Length : Left and Right (Max : 2.5, Min : 2.0)
- \* Screw Torque : Max 2.0kgf cm

Notes : 1. Screw plated through the method of non-electrolytic nickel plating is preferred to reduce possibility that results in vertical and/or horizontal line defect due to the conductive particles from screw surface.

## Product Specification

## 6. Reliability

Environment test condition

No.	Test Item	Conditions
1	High temperature storage test	Ta= 60°C, 240h
2	Low temperature storage test	Ta= -20°C, 240h
3	High temperature operation test	Ta= 50°C, 50%RH, 240h
4	Low temperature operation test	Ta= 0°C, 240h
5	Vibration test (non-operating)	Sine wave, 10 ~ 500 ~ 10Hz, 1.5G, 0.37oct/min 3 axis, 1hour/axis
6	Shock test (non-operating)	Half sine wave, 180G, 2ms one shock of each six faces(I.e. run 180G 2ms for all six faces)
7	Altitude operating storage / shipment	0 ~ 10,000 feet (3,048m) 24Hr 0 ~ 40,000 feet (12,192m) 24Hr

{ Result Evaluation Criteria }

There should be no change which might affect the practical display function when the display quality test is conducted under normal operating condition. —

## 7. International Standards

### 7-1. Safety

- a) UL 60950, Third Edition, Underwriters Laboratories, Inc., Dated Dec. 11, 2000.  
Standard for Safety of Information Technology Equipment, Including Electrical Business Equipment.
- b) CAN/CSA C22.2, No. 60950, Third Edition, Canadian Standards Association, Dec. 1, 2000.  
Standard for Safety of Information Technology Equipment, Including Electrical Business Equipment.
- c) EN 60950 : 2000, Third Edition  
IEC 60950 : 1999, Third Edition  
European Committee for Electro-technical Standardization(CENELEC)  
EUROPEAN STANDARD for Safety of Information Technology Equipment Including Electrical Business Equipment.

### 7-2. EMC

- a) ANSI C63.4 "Methods of Measurement of Radio-Noise Emissions from Low-Voltage Electrical and Electrical Equipment in the Range of 9kHz to 40GHz." American National Standards Institute(ANSI), 1992
- b) C.I.S.P.R "Limits and Methods of Measurement of Radio Interface Characteristics of Information Technology Equipment." International Special Committee on Radio Interference.
- c) EN 55022 "Limits and Methods of Measurement of Radio Interface Characteristics of Information Technology Equipment." European Committee for Electro-technical Standardization.(CENELEC), 1998 ( Including A1: 2000 )

## 8. Packing

### 8-1. Designation of Lot Mark

a) Lot Mark

A	B	C	D	E	F	G	H	I	J	K	L	M
---	---	---	---	---	---	---	---	---	---	---	---	---

A,B,C : Inch

D : Year

E : Month

F : Panel Code

G : Factory Code

H : Assembly Code

I,J,K,L,M : Serial No

Note

1. Year

Year	97	98	99	2000	2001	2002	2003	2004	2005	2006	2007
Mark	7	8	9	0	1	2	3	4	5	6	7

2. Month

Month	Jan	Feb	Mar	Apr	May	Jun	Jul	Aug	Sep	Oct	Nov	Dec
Mark	1	2	3	4	5	6	7	8	9	A	B	C

3. Panel Code

Panel Code	P1 Factory	P2 Factory	P3 Factory	P4 Factory	P5 Factory	Hydis Panel
Mark	1	2	3	4	5	H

4. Factory Code

Factory Code	LPL Gumi	LPL Nanjing	Heesung
Mark	K	C	D

5. Serial No

Serial No.	1 ~ 99,999	100,000 ~
Mark	00001 ~ 99999	A0001 ~ A9999, - - - - , Z9999

b) Location of Lot Mark

Serial NO. is printed on the label. The label is attached to the backside of the LCD module.  
This is subject to change without prior notice.

### 8-2. Packing Form

a) Package quantity in one box : 10 pcs

b) Box Size :372mm × 317mm × 308mm

## 9. PRECAUTIONS

Please pay attention to the followings when you use this TFT LCD module.

### 9-1. MOUNTING PRECAUTIONS

- (1) You must mount a module using holes arranged in four corners or four sides.
- (2) You should consider the mounting structure so that uneven force (ex. Twisted stress) is not applied to the module. And the case on which a module is mounted should have sufficient strength so that external force is not transmitted directly to the module.
- (3) Please attach the surface transparent protective plate to the surface in order to protect the polarizer. Transparent protective plate should have sufficient strength in order to resist external force.
- (4) You should adopt radiation structure to satisfy the temperature specification.
- (5) Acetic acid type and chlorine type materials for the cover case are not desirable because the former generates corrosive gas of attacking the polarizer at high temperature and the latter causes circuit break by electro-chemical reaction.
- (6) Do not touch, push or rub the exposed polarizers with glass, tweezers or anything harder than HB pencil lead. And please do not rub with dust clothes with chemical treatment. Do not touch the surface of polarizer for bare hand or greasy cloth.(Some cosmetics are detrimental to the polarizer.)
- (7) When the surface becomes dusty, please wipe gently with absorbent cotton or other soft materials like chamois soaks with petroleum benzene. Normal-hexane is recommended for cleaning the adhesives used to attach front / rear polarizers. Do not use acetone, toluene and alcohol because they cause chemical damage to the polarizer.
- (8) Wipe off saliva or water drops as soon as possible. Their long time contact with polarizer causes deformations and color fading.
- (9) Do not open the case because inside circuits do not have sufficient strength.

### 9-2. OPERATING PRECAUTIONS

- (1) The spike noise causes the mis-operation of circuits. It should be lower than following voltage :  
 $V = \pm 200\text{mV}$ (Over and under shoot voltage)
- (2) Response time depends on the temperature.(In lower temperature, it becomes longer.)
- (3) Brightness depends on the temperature. (In lower temperature, it becomes lower.)  
And in lower temperature, response time(required time that brightness is stable after turned on) becomes longer.
- (4) Be careful for condensation at sudden temperature change. Condensation makes damage to polarizer or electrical contacted parts. And after fading condensation, smear or spot will occur.
- (5) When fixed patterns are displayed for a long time, remnant image is likely to occur.
- (6) Module has high frequency circuits. Sufficient suppression to the electromagnetic interference shall be done by system manufacturers. Grounding and shielding methods may be important to minimized the interference.

### 9-3. ELECTROSTATIC DISCHARGE CONTROL

Since a module is composed of electronic circuits, it is not strong to electrostatic discharge. Make certain that treatment persons are connected to ground through wrist band etc. And don't touch interface pin directly.

### 9-4. PRECAUTIONS FOR STRONG LIGHT EXPOSURE

Strong light exposure causes degradation of polarizer and color filter.

### 9-5. STORAGE

When storing modules as spares for a long time, the following precautions are necessary.

- (1) Store them in a dark place. Do not expose the module to sunlight or fluorescent light. Keep the temperature between 5°C and 35°C at normal humidity.
- (2) The polarizer surface should not come in contact with any other object.  
It is recommended that they be stored in the container in which they were shipped.

### 9-6. HANDLING PRECAUTIONS FOR PROTECTION FILM

- (1) The protection film is attached to the bezel with a small masking tape.  
When the protection film is peeled off, static electricity is generated between the film and polarizer. This should be peeled off slowly and carefully by people who are electrically grounded and with well ion-blown equipment or in such a condition, etc.
- (2) When the module with protection film attached is stored for a long time, sometimes there remains a very small amount of glue still on the bezel after the protection film is peeled off.
- (3) You can remove the glue easily. When the glue remains on the bezel surface or its vestige is recognized, please wipe them off with absorbent cotton waste or other soft material like chamois soaked with normal-hexane.



Product Specification

**APPENDIX [A] - Enhanced Extended Display Identification Data (EEDID™)**

Byte# (decimal)	Byte# (HEX)	Field Name and Comments	Value (HEX)	Value (binary)	
0	00	Header	0 0	00000000	Header
1	01		F F	11111111	
2	02		F F	11111111	
3	03		F F	11111111	
4	04		F F	11111111	
5	05		F F	11111111	
6	06		F F	11111111	
7	07		0 0	00000000	Vender/ Product ID
8	08	EISA manufacturer code = LGP	3 0	00110000	
9	09		F 0	11110000	
10	0A	Product code	5 3	01010011	
11	0B	(Hex, LSB first)	1 1	00010001	
12	0C	ID (32-bit) serial number = don't care	0 0	00000000	
13	0D		0 0	00000000	
14	0E		0 0	00000000	EDID Version/ Revision
15	0F		0 0	00000000	
16	10	Week of manufacture = don't care	0 0	00000000	
17	11	Year of manufacture = don't care	0 0	00000000	
18	12	EDID Structure version # = 1	0 1	00000001	
19	13	EDID Revision # = 2	0 2	00000010	
20	14	Video input definition = Digital I/p,non TMDS CRGB	8 0	10000000	
21	15	Max H image size(cm)= 30.45cm(30)	1 E	00011110	
22	16	Max V image size(cm)= 22.8375cm(23)	1 7	00010111	
23	17	Display gamma = 2.2	7 8	01111000	
24	18	Feature support(DPMS) = Active off, RGB Color	0 A	00001010	Color Characteristic
25	19	Red/Green low Bits	3 C	00111100	
26	1A	Blue/White Low Bits	8 0	10000000	
27	1B	Red X Rx = 0.590	9 7	10010111	
28	1C	Red Y Ry = 0.343	5 7	01010111	
29	1D	Green X Gx = 0.320	5 1	01010001	
30	1E	Green Y Gy = 0.540	8 A	10001010	
31	1F	Blue X Bx = 0.155	2 7	00100111	
32	20	Blue Y By = 0.133	2 2	00100010	
33	21	White X Wx = 0.313	5 0	01010000	Established Timings
34	22	White Y Wy = 0.329	5 4	01010100	
35	23	Established Timing I	0 0	00000000	
36	24	Established Timing II	0 0	00000000	
37	25	Manufacturer's Timings	0 0	00000000	
38	26	Standard Timing Identification 1 was not used	0 1	00000001	
39	27	Standard Timing Identification 1 was not used	0 1	00000001	
40	28	Standard Timing Identification 2 was not used	0 1	00000001	
41	29	Standard Timing Identification 2 was not used	0 1	00000001	
42	2A	Standard Timing Identification 3 was not used	0 1	00000001	
43	2B	Standard Timing Identification 3 was not used	0 1	00000001	
44	2C	Standard Timing Identification 4 was not used	0 1	00000001	
45	2D	Standard Timing Identification 4 was not used	0 1	00000001	
46	2E	Standard Timing Identification 5 was not used	0 1	00000001	
47	2F	Standard Timing Identification 5 was not used	0 1	00000001	
48	30	Standard Timing Identification 6 was not used	0 1	00000001	
49	31	Standard Timing Identification 6 was not used	0 1	00000001	
50	32	Standard Timing Identification 7 was not used	0 1	00000001	
51	33	Standard Timing Identification 7 was not used	0 1	00000001	
52	34	Standard Timing Identification 8 was not used	0 1	00000001	
53	35	Standard Timing Identification 8 was not used	0 1	00000001	

Product Specification

Byte# (decimal)	Byte# (HEX)	Field Name and Comments	Value (HEX)	Value (binary)	
54	36	Detailed Timing Descriptor #1	3 0	00110000	<b>Detailed Timing Description #1</b>
55	37	1400 x1050@60Hz mode : pixel clock = 109MHz	2 A	00101010	
56	38	Horizontal Active = 1400 pixels	7 8	01111000	
57	39	Horizontal Blanking = 288 pixels	2 0	00100000	
58	3A	Horizontal Active : Horizontal Blanking	5 1	01010001	
59	3B	Vertical Active = 1050 lines	1 A	00011010	
60	3C	Vertical Blanking = 16 lines	1 0	00010000	
61	3D	Vertical Active : Vertical Blanking	4 0	01000000	
62	3E	Horizontal Sync. Offset = 32 pixels	2 0	00100000	
63	3F	Horizontal Sync Pulse Width = 112 pixels	7 0	01110000	
64	40	Vertical Sync Offset = 2 lines, Sync Width = 4 lines	2 4	00100100	
65	41	Horizontal Vertical Sync Offset/Width upper 2bits	0 0	00000000	
66	42	Horizontal Image Size = 304.5mm (305)	3 1	00110001	
67	43	Vertical Image Size = 228.375mm (228)	E 4	11100100	
68	44	Horizontal & Vertical Image Size	1 0	00010000	
69	45	Horizontal Border = 0	0 0	00000000	
70	46	Vertical Border = 0	0 0	00000000	
71	47	Non -interlaced, Normal display, no stereo, Digital separate sync, H/V pol negatives	1 8	00011000	
72	48	Detailed Timing Descriptor #2	0 0	00000000	<b>Detailed Timing Description #2</b>
73	49		0 0	00000000	
74	4A		0 0	00000000	
75	4B		0 0	00000000	
76	4C		0 0	00000000	
77	4D		0 0	00000000	
78	4E		0 0	00000000	
79	4F		0 0	00000000	
80	50		0 0	00000000	
81	51		0 0	00000000	
82	52		0 0	00000000	
83	53		0 0	00000000	
84	55		0 0	00000000	
85	55		0 0	00000000	
86	56		0 0	00000000	
87	57		0 0	00000000	
88	58		0 0	00000000	
89	59		0 0	00000000	
90	5A	Detailed Timing Descriptor #3	0 0	00000000	<b>Detailed Timing Description #3</b>
91	5B		0 0	00000000	
92	5C	ASCII Data String Tag (Supplier Name)	0 0	00000000	
93	5D		F E	11111110	
94	5E		0 0	00000000	
95	5F	L	4 C	01001100	
96	60	G	4 7	01000111	
97	61	P	5 0	01010000	
98	62	h	6 8	01101000	
99	63	i	6 9	01101001	
100	64	i	6 C	01101100	
101	65	i	6 9	01101001	
102	66	p	7 0	01110000	
103	67	s	7 3	01110011	
104	68	L	4 C	01001100	
105	69	C	4 3	01000011	
106	6A	D	4 4	01000100	
107	6B	LF (Line Feed)	0 A	00001010	
108	6C	Detailed Timing Descriptor #4	0 0	00000000	<b>Detailed Timing Description #4</b>
109	6D		0 0	00000000	
110	6E	ASCII Data String Tag (Supplier S/N)	0 0	00000000	
111	6F		F E	11111110	
112	70		0 0	00000000	
113	71	L	4 C	01001100	
114	72	P	5 0	01010000	
115	73	1	3 1	00110001	
116	74	5	3 5	00110101	
117	75	0	3 0	00110000	
118	76	E	4 5	01000101	
119	77	0	3 0	00110000	
120	78	6	3 6	00110110	
121	79	-	2 D	00101101	
122	7A	A	4 1	01000001	
123	7B	3	3 3	00110011	
124	7C	K	4 B	01001011	
125	7D	2	3 2	00110010	
126	7E	Extension flag = 00	0 0	00000000	<b>Extension Flag</b>
127	7F	Checksum	E 8	11101000	<b>Checksum</b>