

**Product Specification**

# SPECIFICATION FOR APPROVAL

- ( ) Preliminary Specification  
 (◆) Final Specification

<b>Title</b>	<b>15.0" XGA TFT LCD</b>
--------------	--------------------------

BUYER	General
MODEL	

SUPPLIER	LG.Philips LCD CO., Ltd.
*MODEL	LP150X09
SUFFIX	A5K1

\*When you obtain standard approval,  
 please use the above model name without suffix

SIGNATURE	DATE
_____/_____  	_____  
_____/_____  	_____  
_____/_____  	_____  

Please return 1 copy for your confirmation with your signature and comments.

APPROVED BY	DATE
J. H. Lee /S.Manager _____	_____  
REVIEWED BY G. J. Han / Manager S. M. Lee / Manager _____	_____  
PREPARED BY J. H. Park / Engineer J.H. Kim / Engineer _____	_____  

Product Engineering Dept.  
 LG. Philips LCD Co., Ltd

**Product Specification**
**Contents**

<b>NO.</b>	<b>ITEM</b>	<b>Page</b>
-	COVER	1
-	CONTENTS	2
-	RECORD OF REVISIONS	3
1	GENERAL DESCRIPTION	4
2	ABSOLUTE MAXIMUM RATINGS	5
3	ELECTRICAL SPECIFICATIONS	6
3-1	ELECTRICAL CHARACTERISTICS	6
3-2	INTERFACE CONNECTIONS	8
3-3	SIGNAL TIMING SPECIFICATIONS	9
3-4	SIGNAL TIMING WAVEFORMS	9
3-5	COLOR INPUT DATA REFERENCE	10
3-6	POWER SEQUENCE	11
4	OPTICAL SPECIFICATIONS	12
5	MECHANICAL CHARACTERISTICS	16
6	RELIABILITY	20
7	INTERNATIONAL STANDARDS	21
7-1	SAFETY	21
7-2	EMC	21
8	PACKING	22
8-1	DESIGNATION OF LOT MARK	22
8-2	PACKING FORM	22
8-3	LABEL DESCRIPTION	23
9	PRECAUTIONS	24
9-1	MOUNTING PRECAUTIONS	24
9-2	OPERATING PRECAUTIONS	24
9-3	ELECTROSTATIC DISCHARGE CONTROL	25
9-4	PRECAUTIONS FOR STRONG LIGHT EXPOSURE	25
9-5	STORAGE	25
9-6	HANDLING PRECAUTIONS FOR PROTECTION FILM	25



**Product Specification**

**1. General Description**

The LP150X09 is a Color Active Matrix Liquid Crystal Display with an integral Cold Cathode Fluorescent Lamp(CCFL) backlight system. The matrix employs a-Si Thin Film Transistor as the active element. It is a transmissive type display operating in the normally white mode. This TFT-LCD has a 15.0 inch diagonally measured active display area with XGA resolution(768 vertical by 1024 horizontal pixel array). Each pixel is divided into Red, Green and Blue sub-pixels or dots which are arranged in vertical stripes. Gray scale or the brightness of the sub-pixel color is determined with a 6-bit gray scale signal for each dot, thus, presenting a palette of more than 262,144 colors.

The LP150X09 has been designed to apply the interface method that enables low power, high speed, low EMI. Flat Link must be used as a LVDS(Low Voltage Differential Signaling) chip.

The LP150X09 is intended to support applications where thin thickness, low power are critical factors and graphic displays are important. In combination with the vertical arrangement of the sub-pixels, the LP150X09 characteristics provide an excellent flat display for office automation products such as Notebook PC.

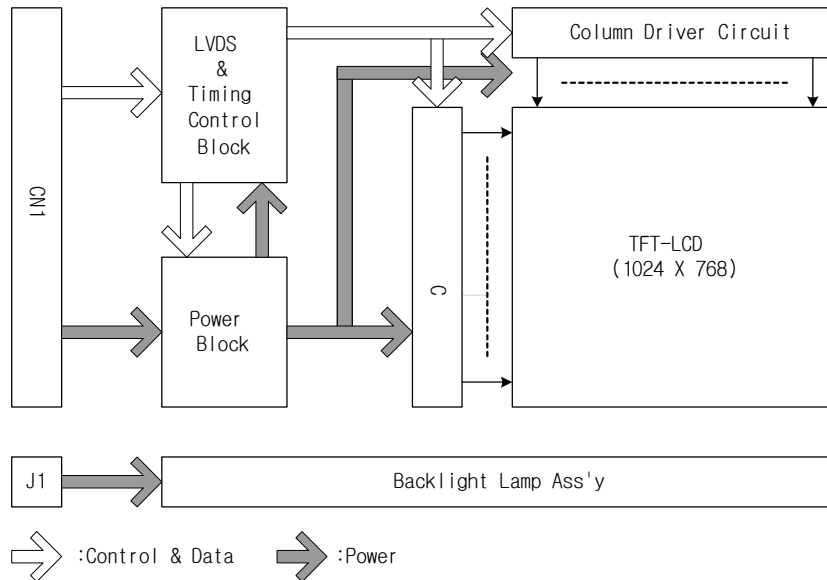

**General Features**

Active screen size	15.0 inch(38.1cm) diagonal
Outline Dimension	317.3(H) x 241.5(V) x 5.7(D) mm(Typ)
Pixel Pitch	0.297(H) x 0.297(V) mm
Pixel format	1024 horiz. By 768 vert. Pixels RGB stripes arrangement
Color depth	6-bit, 262,144 colors
Luminance, white	200 cd/m <sup>2</sup> (Typ.) Center 1Point
Power Consumption	4.91 W (Windows Typ)
Weight	500g(Typ.)
Display operating mode	Transmissive mode, normally white
Surface treatments	Anti-glare & hard coating 2H, Anti-Reflection

**Product Specification**

## 2. Absolute Maximum Ratings

The following are maximum values which, if exceeded, may cause faulty operation or damage to the unit.

**Table 1. ABSOLUTE MAXIMUM RATINGS**

Parameter	symbol	Values		Units	Notes
		Min.	Max.		
Power Input Voltage	$V_{CC}$	-0.3	4.0	Vdc	At $25 \pm 5^{\circ}\text{C}$
Operating Temperature	$T_{OP}$	0	50	$^{\circ}\text{C}$	1
Storage Temperature	$T_{ST}$	-20	60	$^{\circ}\text{C}$	1
Operating Ambient Humidity	$H_{OP}$	10	90	%RH	1
Storage Humidity	$H_{ST}$	10	90	%RH	1

Note : 1. Temperature and relative humidity range are shown in the figure below.  
Wet bulb temperature should be  $39^{\circ}\text{C}$  Max, and no condensation of water.

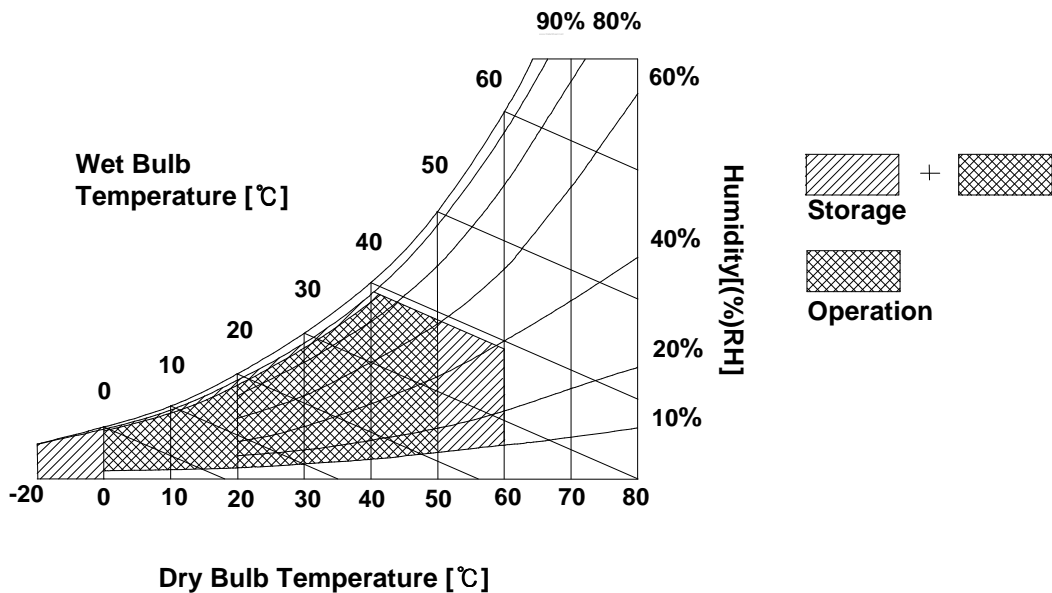

**Product Specification**

### 3. Electrical Specifications

#### 3-1. Electrical Characteristics

The LP150X09 requires two power inputs. One is employed to power the LCD electronics and to drive the TFT array and liquid crystal. The second input which powers the CCFL, is typically generated by an inverter. The inverter is an external unit to the LCD.

Parameter	Symbol	Values			Unit	Notes
		Min	Typ	Max		
<b>MODULE :</b>						
Power Supply Input Voltage	VCC	3.0	3.3	3.6	Vdc	
Power Supply Input Current	I <sub>CC</sub>	-	245	285	mA	1
Window		-	275	315		
Full Black 2 by 2 sub pixel		-	300	345		
Power Consumption	P <sub>c</sub>	-	0.81	0.94	Watt	1
Differential Impedance	Z <sub>m</sub>	90	100	110	ohm	2
<b>LAMP :</b>						
Operating Voltage	V <sub>BL</sub>	660(6.5mA)	680(6.0mA)	860(2.3mA)	V <sub>RMS</sub>	3
Operating Current	I <sub>BL</sub>	2.3	6.0	6.5	mA <sub>RMS</sub>	
Established Starting Voltage	V <sub>s</sub>					4
				1230	V <sub>RMS</sub>	
at 25 °C		-	-			
at 0 °C		-	-	1400	V <sub>RMS</sub>	
Operating Frequency	f <sub>BL</sub>	40	60	80	kHz	5
Discharge Stabilization Time	T <sub>s</sub>	-	-	3	Min	6
Power Consumption	P <sub>BL</sub>	-	4.1	4.5	Watt	7
Life Time		10,000	-	-	Hrs	8

Notes : **The design of the inverter must have specification for the lamp in LCD Assembly.**

The performance of the Lamp in LCM, for example life time or brightness, is extremely influenced by the characteristics of the DC-AC inverter. So all the parameters of an inverter should be carefully designed so as not to produce too much leakage current from high-voltage output of the inverter.

When you design or order the inverter, please make sure unwanted lighting caused by the mismatch of the lamp and the inverter(no lighting, flicker, etc) never occurs. When you confirm it, the LCD Assembly should be operated in the same condition as installed in your instrument.

1. The specified current and power consumption are under the VCC=3.3V, 25°C, f<sub>v</sub>=60Hz condition whereas Window pattern is displayed and f<sub>v</sub> is the frame frequency.
2. This impedance value is needed to proper display and measured from LVDS T<sub>x</sub> to the mating connector.
3. The variance of the voltage is ± 10%.
4. The voltage above V<sub>s</sub> should be applied to the lamps for more than 1 second for start-up. Otherwise, the lamps may not be turned on. The used lamp current is the lamp typical current.

**Product Specification**

5. The output of the inverter must have symmetrical(negative and positive) voltage waveform and symmetrical current waveform.(Unsymmetrical ratio is less than 10%) Please do not use the inverter which has unsymmetrical voltage and unsymmetrical current and spike wave.  
Lamp frequency may produce interference with horizontal synchronous frequency and as a result this may cause beat on the display. Therefore lamp frequency shall be as away possible from the horizontal synchronous frequency and from its harmonics in order to prevent interference.
  6. Let's define the brightness of the lamp after being lighted for 5 minutes as 100%.  
 $T_s$  is the time required for the brightness of the center of the lamp to be not less than 95%.
  7. The lamp power consumption shown above does not include loss of external inverter.  
The used lamp current is the typical lamp current ( $6.0mA_{RMS}$ ).
  8. The life time is determined as the time at which brightness of the lamp is 50% compared to that of initial value at the typical lamp current on condition of continuous operating at  $25 \pm 2^\circ C$ .
- \* Requirements for a system inverter design, which is intended to have a better display performance, a better power efficiency and a more reliable lamp, are following. It shall help increase the lamp lifetime and reduce leakage current.
- a. The asymmetry rate of the inverter waveform should be less than 10%.
  - b. The distortion rate of the waveform should be within  $\sqrt{2} \pm 10\%$ .
- \* Inverter output waveform had better be more similar to ideal sine wave.

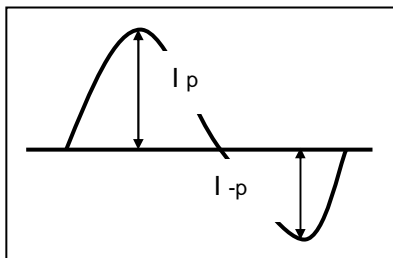

\* Asymmetry rate:

$$\frac{|I_p - I_{-p}|}{I_{rms}} * 100\%$$

\* Distortion rate

$$I_p \text{ (or } I_{-p}) / I_{rms}$$

- \* Do not attach a conducting tape to lamp connecting wire.  
If the lamp wire attach to a conducting tape, TFT-LCD Module has a low luminance and the inverter has abnormal action. Because leakage current is occurred between lamp wire and conducting tape.

**Product Specification**
**3-2. Interface Connections**

Interface chip must be used FlatLink, part No. SN75LVDS84(Transmitter made by Texas Instrument Inc or equivalence).

This LCD employs two interface connections, a 30 pin connector is used for the module electronics interface and the other connector is used for the integral backlight system.

The electronics interface connector is a model FI-XB30SR-HF11 manufactured by JAE

The pin configuration for the connector is shown in the table 3.

**Table 3. MODULE CONNECTOR PIN CONFIGURATION(LVDS)**

Pin	Symbol	Description	Notes
1	GND	Ground	1. LVDS Interfacing 1.1 System : SN75LVDS84(TI) or equivalent *Pin to Pin compatible with Thine LVDS  1.2 LCD : THC63LVD64A(THINE)  2. Connector 2.1 LCD : JAE FI-XB30SR-HF11 2.2 Mating : JAE FI-X30M or equivalent 2.3 Connector pin arrangement   <b>[ LCD Module Rear View ]</b>
2	Vcc	Power(3.3V)	
3	Vcc	Power(3.3V)	
4	V_EDID	No Connection	
5	NC	Test Pin for supplier	
6	CLK_EDID	No Connection	
7	DATA_EDID	No Connection	
8	A1M	Differential Signal	
9	A1P	Differential Signal	
10	GND	Ground	
11	A2M	Differential Signal	
12	A2P	Differential Signal	
13	GND	Ground	
14	A3M	Differential Signal	
15	A3P	Differential Signal	
16	GND	Ground	
17	CLKM	Differential Signal	
18	CLKP	Differential Signal	
19	GND	Ground	
20	NC	No Connection	
21	NC	No Connection	
22	GND	Ground	
23	NC	No Connection	
24	NC	No Connection	
25	GND	Ground	
26	NC	No Connection	
27	NC	No Connection	
28	GND	Ground	
29	NC	No Connection	
30	NC	No Connection	

The backlight interface connector is a model BHSR-02VS-1, manufactured by JST. The mating connector part number is SM02B-BHS-1 or equivalent.

The pin configuration for the connector is shown in the table below.

**Table 4. BACKLIGHT CONNECTOR PIN CONFIGURATION**

Pin	Symbol	Description	Notes
1	HV	Power supply for lamp (High voltage side)	1
2	LV	Power supply for lamp (Low voltage side)	1

Notes : 1. The high voltage side terminal is colored pink. The low voltage side terminal is white



**Product Specification**

### 3-3. Signal Timing Specifications

This is the signal timing required at the input of the User connector. All of the interface signal timing should be satisfied with the following specifications and specifications of LVDS Tx/Rx for it's proper operation.

**Table 5. Timing Table**

	ITEM	SYMBOL	MIN	TYP	MAX	UNIT	NOTES
Dclk	Frequency	-	40	65	68	MHz	
Hsync	Period	$t_{HP}$	1206	1344	1364	$t_{CLK}$	
	Width	$t_{WH}$	8	136	-		
Vsync	Period	$t_{VP}$	780	806	830	$t_{HP}$	
	Frequency	$f_V$	40	60	60	Hz	Don't care Flicker level at 40 Hz
	Width	$t_{WV}$	1	6	-	$t_{HP}$	
DE (Data Enable)	Horizontal Valid	$t_{HV}$	1024	1024	1024	$t_{CLK}$	
	Horizontal Back Porch	$t_{HBP}$	10	160	-		
	Horizontal Front Porch	$t_{HFP}$	10	24	-		
	Vertical Valid	$t_{VV}$	768	768	768	$t_{HP}$	
	Vertical Back Porch	$t_{VBP}$	7	29	-		
	Vertical Front Porch	$t_{VFP}$	1	3	-		

### 3-4. Signal Timing Waveforms

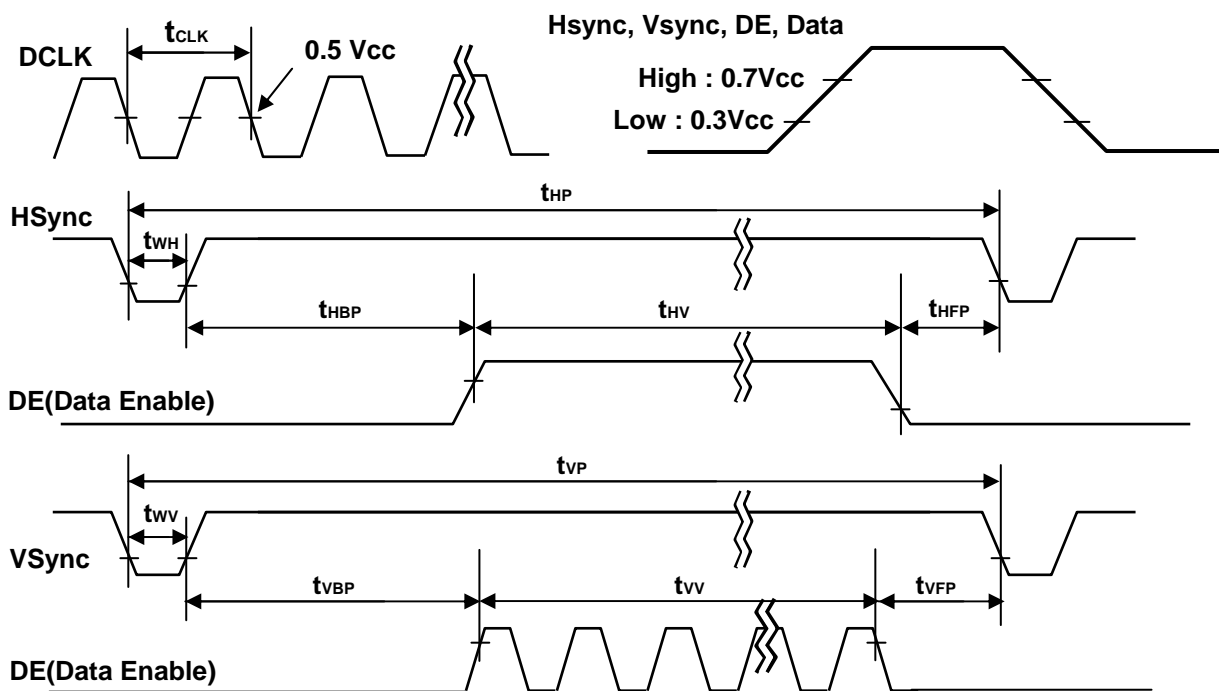

**Product Specification**
**3-5. Color Input Data Reference**

The brightness of each primary color(red,green and blue) is based on the 6-bit gray scale data input for the color ; the higher the binary input, the brighter the color. The table below provides a reference for color versus data input.

**Table 6. COLOR DATA REFERENCE**

Color		Input Color Data																	
		Red						Green						Blue					
		MSB		LSB				MSB		LSB				MSB		LSB			
		R5	R4	R3	R2	R1	R0	G5	G4	G3	G2	G1	G0	B5	B4	B3	B2	B1	B0
Basic Colors	Black	0	0	0	0	0	0	0	0	0	0	0	0	0	0	0	0	0	0
	Red(63)	1	1	1	1	1	1	0	0	0	0	0	0	0	0	0	0	0	0
	Green(63)	0	0	0	0	0	0	1	1	1	1	1	1	0	0	0	0	0	0
	Blue(63)	0	0	0	0	0	0	0	0	0	0	0	0	1	1	1	1	1	1
	Cyan	0	0	0	0	0	0	1	1	1	1	1	1	1	1	1	1	1	1
	Magenta	1	1	1	1	1	1	0	0	0	0	0	0	1	1	1	1	1	1
	Yellow	1	1	1	1	1	1	1	1	1	1	1	1	0	0	0	0	0	0
	White	1	1	1	1	1	1	1	1	1	1	1	1	1	1	1	1	1	1
Red	Red(00) Dark	0	0	0	0	0	0	0	0	0	0	0	0	0	0	0	0	0	0
	Red(01)	0	0	0	0	0	1	0	0	0	0	0	0	0	0	0	0	0	0
	Red(02)	0	0	0	0	1	0	0	0	0	0	0	0	0	0	0	0	0	0
	:	:	:	:	:	:	:	:	:	:	:	:	:	:	:	:	:	:	:
	Red(61)	1	1	1	1	0	1	0	0	0	0	0	0	0	0	0	0	0	0
	Red(62)	1	1	1	1	1	0	0	0	0	0	0	0	0	0	0	0	0	0
	Red(63) Bright	1	1	1	1	1	1	0	0	0	0	0	0	0	0	0	0	0	0
Green	Green(00)Dark	0	0	0	0	0	0	0	0	0	0	0	0	0	0	0	0	0	0
	Green(01)	0	0	0	0	0	0	0	0	0	0	0	1	0	0	0	0	0	0
	Green(02)	0	0	0	0	0	0	0	0	0	0	1	0	0	0	0	0	0	0
	:	:	:	:	:	:	:	:	:	:	:	:	:	:	:	:	:	:	:
	Green(61)	0	0	0	0	0	0	1	1	1	1	0	1	0	0	0	0	0	0
	Green(62)	0	0	0	0	0	0	1	1	1	1	1	0	0	0	0	0	0	0
	Green(63)Bright	0	0	0	0	0	0	1	1	1	1	1	1	0	0	0	0	0	0
Blue	Blue(00) Dark	0	0	0	0	0	0	0	0	0	0	0	0	0	0	0	0	0	0
	Blue(01)	0	0	0	0	0	0	0	0	0	0	0	0	0	0	0	0	0	1
	Blue(02)	0	0	0	0	0	0	0	0	0	0	0	0	0	0	0	0	1	0
	:	:	:	:	:	:	:	:	:	:	:	:	:	:	:	:	:	:	:
	Blue(61)	0	0	0	0	0	0	0	0	0	0	0	0	1	1	1	1	0	1
	Blue(62)	0	0	0	0	0	0	0	0	0	0	0	0	1	1	1	1	1	0
	Blue(63) Bright	0	0	0	0	0	0	0	0	0	0	0	0	1	1	1	1	1	1

**Product Specification**

**3-6. Power Sequence**

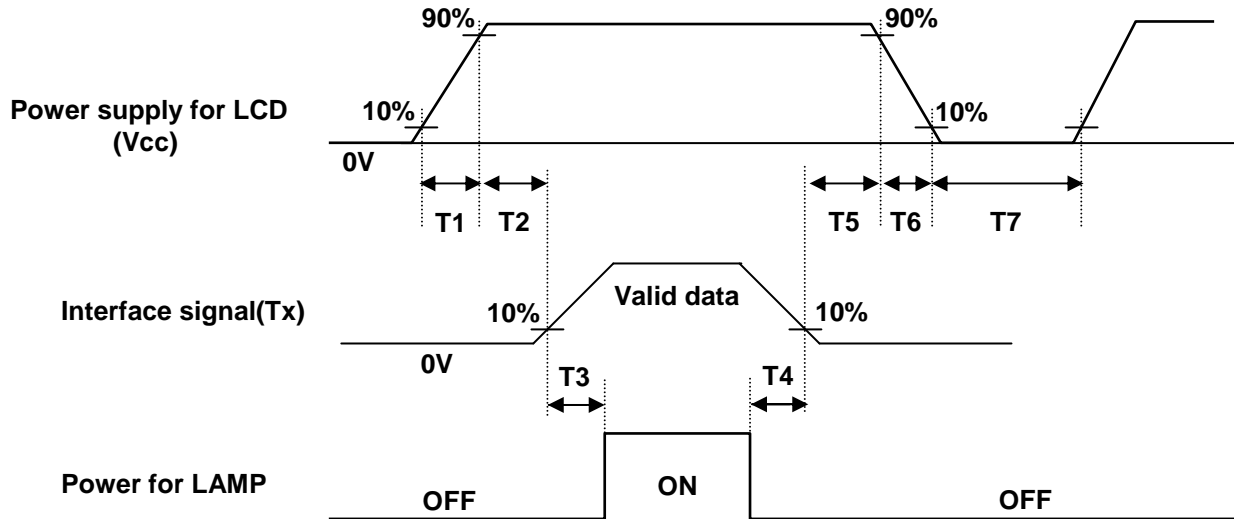

**Table 7. POWER SEQUENCE TABLE**

Parameter	Values			Units
	Min.	Typ.	Max.	
T 1	0	—	10	(ms)
T 2	0	—	50	(ms)
T 3	200	—	—	(ms)
T 4	0	—	—	(ms)
T 5	0	—	50	(ms)
T 6	0	—	300	(ms)
T 7	100	—	—	(ms)

- Notes :
1. Please avoid floating state of interface signal at invalid period.
  2. When the interface signal is invalid, be sure to pull down the power supply for LCD  $V_{CC}$  to 0V.
  3. Lamp power must be turn on after power supply for LCD and interface signals are valid.

**Product Specification**

**4. Optical Specification**

Optical characteristics are determined after the unit has been 'ON' and stable for approximately 30 minutes in a dark environment at 25°C. The values specified are at an approximate distance 50cm from the LCD surface at a viewing angle of  $\Phi$  and  $\Theta$  equal to 0°.

FIG. 1 presents additional information concerning the measurement equipment and method.

**FIG. 1 Optical Characteristic Measurement Equipment and Method**

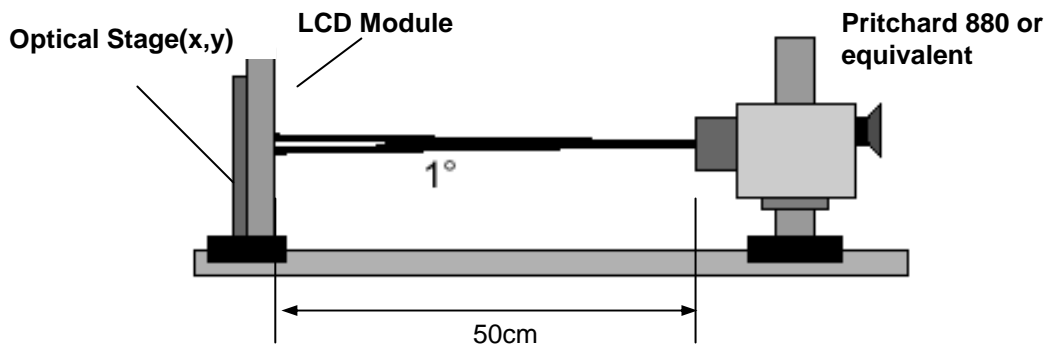

**Table 8. OPTICAL CHARACTERISTICS** (Ta=25 °C, V<sub>CC</sub>=3.3V, f<sub>V</sub>=60Hz Dclk=65MHz, I<sub>BL</sub>=6.0mAms)

Parameter	Symbol	Values			Units	Notes
		Min.	Typ.	Max.		
Contrast Ratio	CR	150	200	-		1
Surface Luminance, white	L <sub>WH</sub>	170	200	-	cd/m <sup>2</sup>	2
Luminance Variation	$\delta_{\text{WHITE}}$	77 55	-	-	5points 13points	3
Response Time						4
Rise Time	T <sub>R</sub>	-	10	20	ms	
Decay Time	T <sub>D</sub>	-	20	30	ms	
CIE Color Coordinates						
Red	XR	0.558	0.588	0.618		
	YR	0.314	0.344	0.374		
Green	XG	0.290	0.320	0.350		
	YG	0.508	0.538	0.568		
Blue	XB	0.130	0.160	0.190		
	YB	0.116	0.146	0.176		
White	XW	0.285	0.313	0.341		
	YW	0.309	0.329	0.349		
Viewing Angle						
x axis, right( $\phi=0^\circ$ )	$\theta_r$	40	45	-	degree	5
x axis, left ( $\phi=180^\circ$ )	$\theta_l$	40	45	-	degree	
y axis, up ( $\phi=90^\circ$ )	$\theta_u$	10	15	-	degree	
y axis, down ( $\phi=270^\circ$ )	$\theta_d$	30	35	-	degree	
Gray Scale	-	-	-	-		6

\* Measured Inverter : 6632Z-1301A(LG Electronics)

**Product Specification**

Notes : 1. Contrast Ratio(CR) is defined mathematically as :

$$\text{Contrast Ratio} = \frac{\text{Surface Luminance with all white pixels}}{\text{Surface Luminance with all black pixels}}$$

2. Surface luminance is the **center point** across the LCD surface 50cm from the surface with all pixels displaying white under the condition of  $I_{BL}=6.0\text{mA}$ . For more information see FIG 1.
3. The variation in surface luminance , **The Panel total variation ( $\delta_{\text{WHITE}}$ )** is determined by measuring  $L_N$  at each test position 1 through 13, and then dividing the minimum  $L_N$  of 13 points luminance by maximum  $L_N$  of 13 points luminance. For more information see FIG 2.  

$$\delta_{\text{WHITE}} = \frac{\text{Minimum}(L_{N1}, L_{N2}, \dots, L_{N13})}{\text{Maximum}(L_{N1}, L_{N2}, \dots, L_{N13})} * 100$$
4. Response time is the time required for the display to transition from white to black(Rise Time,  $Tr_R$ ) and from black to white(Decay Time,  $Tr_D$ ). For additional information see FIG 3.
5. Viewing angle is the angle at which the contrast ratio is greater than 10. The angles are determined for the horizontal or x axis and the vertical or y axis with respect to the z axis which is normal to the LCD surface. For more information see FIG 4.
6. Gray scale specification

\*  $f_V=60\text{Hz}$

Gray Level	Luminance(%) (Typ.)
L0	0.24
L7	0.76
L15	3.37
L23	9.60
L31	21.4
L39	37.0
L47	56.8
L55	79.2
L63	100

Product Specification

FIG. 2 Luminance & Luminance variation

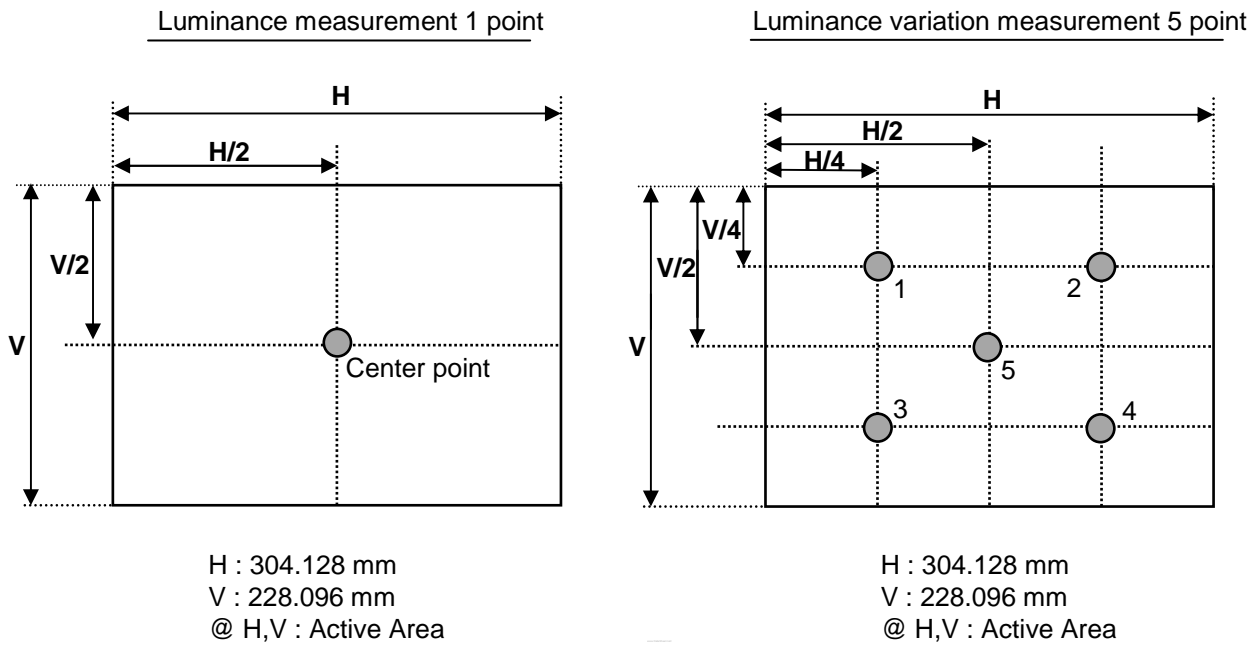

Luminance variation measurement 13 point

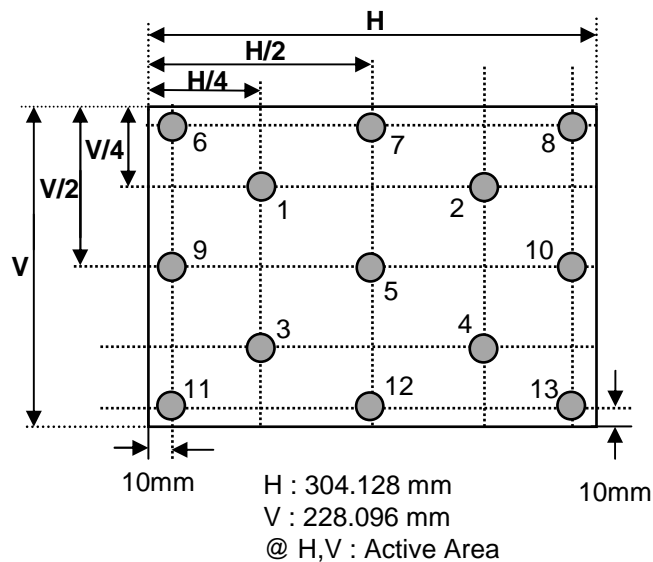

Notes) The Adjacent point must be opposite horizontally or vertically.



**Product Specification**

**5. Mechanical Characteristics**

The contents provide general mechanical characteristics for the model LP150X09. In addition the figures in the next page are detailed mechanical drawing of the LCD.

This panel conforms to SPWG Style-B except for the thickness and cable length.

Outside dimensions	Horizontal	317.3 ± 0.5mm
	Vertical	241.5 ± 0.5mm
	Depth	5.7 ± 0.3mm
Bezel area	Horizontal	307.5 ± 0.5mm
	Vertical	231.4 ± 0.5mm
Active display area	Horizontal	304.128mm
	Vertical	228.096mm
Weight	500g(Typ.) 515g(Max)	
Surface Treatment	Anti-glare & hard coating 2H, Anti-Reflection	





Product Specification

<FRONT VIEW>

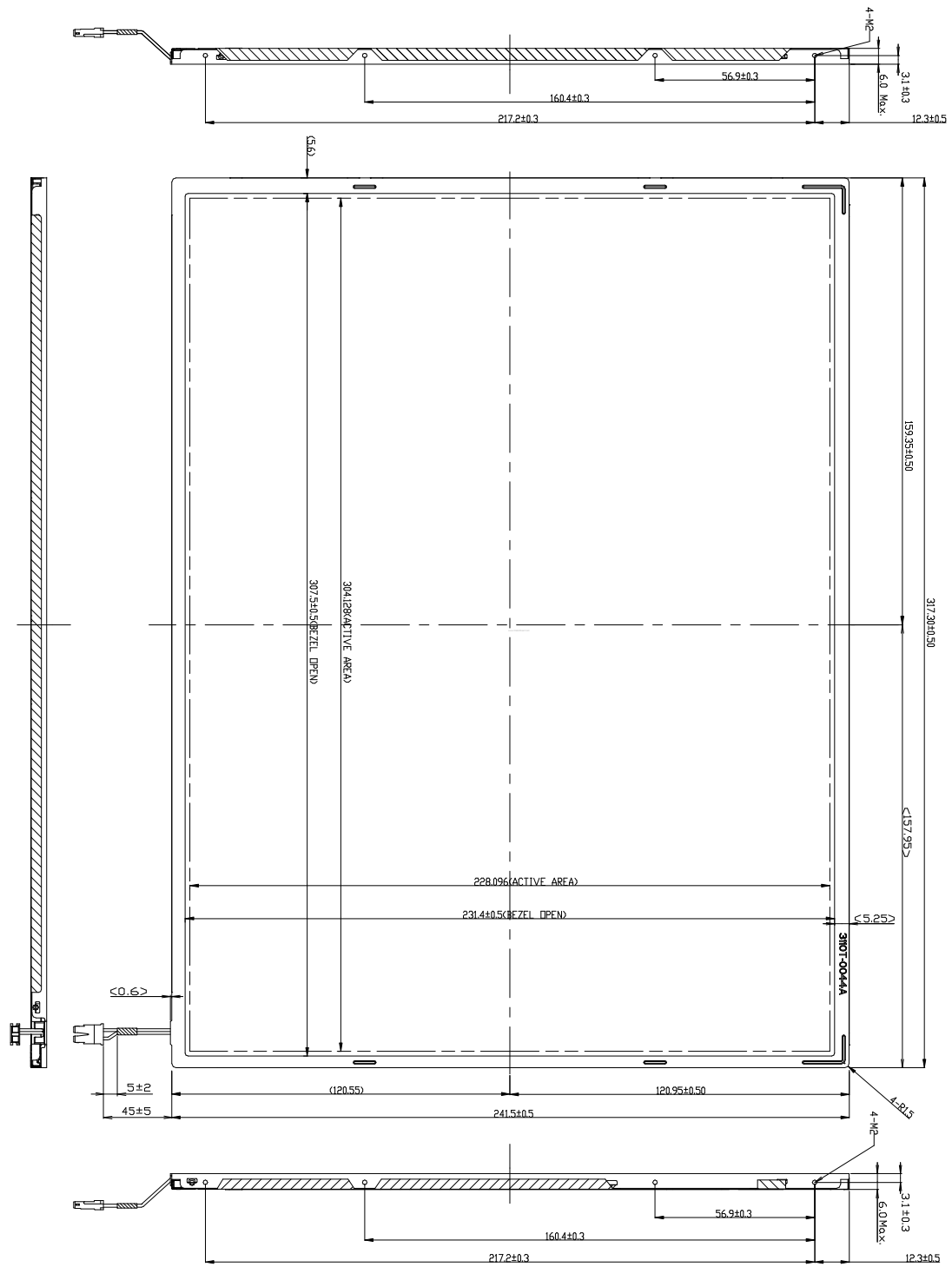



Product Specification

<DETAIL DESCRIPTION OF SIDE MOUNTING SCREW>

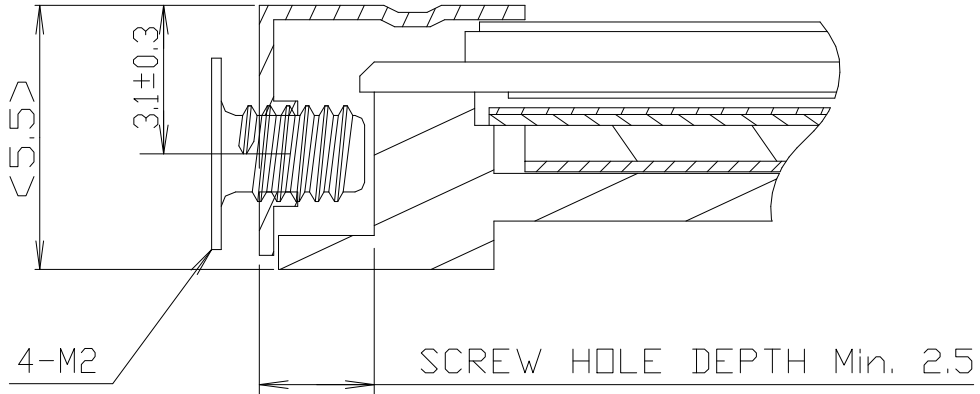

SCREW TORQUE : 2.3~2.5kgf·cm

SECTION "A"-"A"  
SCALE 5/1

Notes : 1. Screw plated through the method of non-electrolytic nickel plating is preferred to reduce possibility that results in vertical and/or horizontal line defect due to the conductive particles from screw surface.

**Product Specification****6. Reliability**

Environment test condition

No.	Test Item	Conditions
1	High temperature storage test	Ta= 60°C 240h
2	Low temperature storage test	Ta= -20°C 240h
3	High temperature operation test	Ta= 50°C 50%RH 240h
4	Low temperature operation test	Ta= 0°C 240h
5	Vibration test (non-operating)	Sine wave, 10 ~ 500 ~ 10Hz, 1.5G, 0.37oct/min 3 axis, 1hour/axis
6	Shock test (non-operating)	Half sine wave, 100G, 6ms one shock of each six faces(I.e. run 100G 6ms for all six faces)
7	Altitude operating storage / shipment	0 ~ 10,000 feet (3,048m) 24Hr 0 ~ 40,000 feet (12,192m) 24Hr

{ Result Evaluation Criteria }

There should be no change which might affect the practical display function when the display quality test is conducted under normal operating condition.

- ON/OFF Cycle

: The display module will be capable of being operated over 24,000 ON/OFF cycles (Lamp power & Vcc ON/OFF)

- Mean time Between Failure

: The LCD Panel and interface board assembly (excluding the CCFL) have a mean time between failures of 30,000 hours with a confidence level 90%.

**Product Specification****7. International Standards****7-1. Safety**

- a) UL 60950, Third Edition, Underwriters Laboratories, Inc., Dated Dec. 11, 2000.  
Standard for Safety of Information Technology Equipment, Including Electrical Business Equipment.
- b) CAN/CSA C22.2, No. 60950, Third Edition, Canadian Standards Association, Dec. 1, 2000.  
Standard for Safety of Information Technology Equipment, Including Electrical Business Equipment.
- c) EN 60950 : 2000, Third Edition  
IEC 60950 : 1999, Third Edition  
European Committee for Electrotechnical Standardization(CENELEC)  
EUROPEAN STANDARD for Safety of Information Technology Equipment Including Electrical Business Equipment.

**7-2. EMC**

- a) ANSI C63.4 "Methods of Measurement of Radio-Noise Emissions from Low-Voltage Electrical and Electrical Equipment in the Range of 9kHz to 40GHz. "American National Standards Institute(ANSI), 1992
- b) C.I.S.P.R "Limits and Methods of Measurement of Radio Interface Characteristics of Information Technology Equipment." International Special Committee on Radio Interference.
- c) EN 55022 "Limits and Methods of Measurement of Radio Interface Characteristics of Information Technology Equipment." European Committee for Electrotechnical Standardization.(CENELEC), 1998 ( Including A1: 2000 )

**Product Specification**

**8. Packing**

**8-1. Designation of Lot Mark**

a) Lot Mark

A	B	C	D	E	F	G	H	I	J	K	L	M
---	---	---	---	---	---	---	---	---	---	---	---	---

A,B,C : SIZE(INCH)

E : MONTH

G : ASSEMBLY CODE

D : YEAR

F : FACTORY CODE

H ~ M : SERIAL NO.

Note

1. YEAR

Year	2001	2002	2003	2004	2005	2006	2007	2008	2009	2010
Mark	1	2	3	4	5	6	7	8	9	0

2. MONTH

Month	Jan	Feb	Mar	Apr	May	Jun	Jul	Aug	Sep	Oct	Nov	Dec
Mark	1	2	3	4	5	6	7	8	9	A	B	C

3. FACTORY CODE

Factory Code	LPL Gumi	LPL Nanjing	HEESUNG
Mark	K	C	D

4. SERIAL NO.

Mark	100001~199999, 200001~299999, 300001~399999, ....., A00001~A99999, ....., Z00001~Z99999
------	---

b) Location of Lot Mark

Serial No. is printed on the label. The label is attached to the backside of the LCD module.  
This is subject to change without prior notice.

**8-2. Packing Form**

a) Package quantity in one box : 12 pcs

b) Box size : 376mm X 321mm X 317mm.

**Product Specification**

**8-3. Label Description**

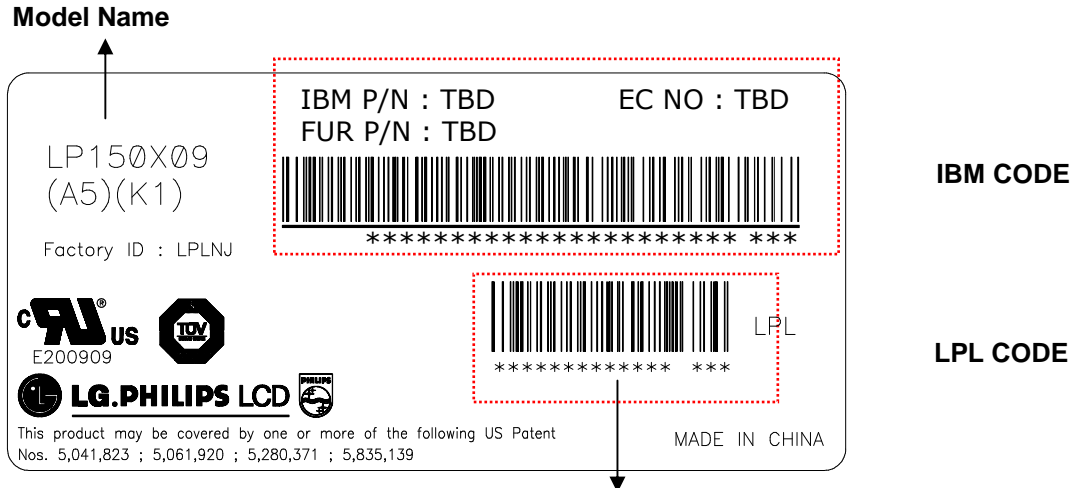

**LPL Code**

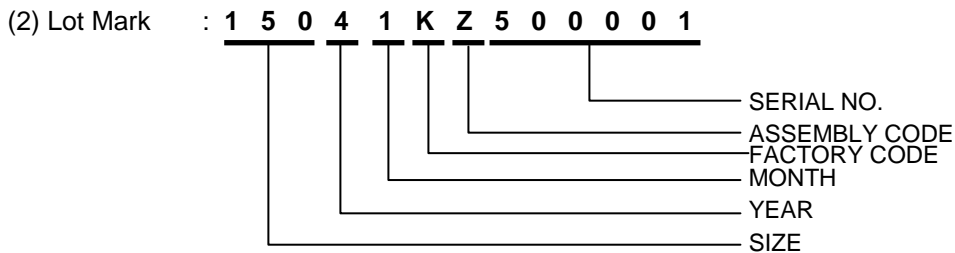
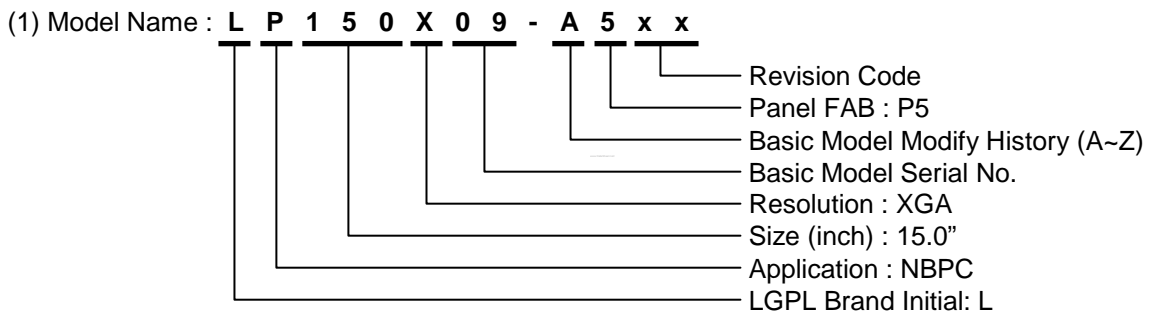

**IBM Code**

- 1)IBM P/N :TBD
- 2)EC NO :TBD
- 3)FRU P/N :TBD
- 4)Header Code :TBD

**Product Specification****9. PRECAUTIONS**

Please pay attention to the following when you use this TFT LCD module.

**9-1. MOUNTING PRECAUTIONS**

- (1) You must mount a module using holes arranged in four corners.
- (2) You should consider the mounting structure so that uneven force(ex. Twisted stress) is not applied to the module.  
And the case on which a module is mounted should have sufficient strength so that external force is not transmitted directly to the module.
- (3) Please attach the surface transparent protective plate to the surface in order to protect the polarizer. Transparent protective plate should have sufficient strength in order to resist external force.
- (4) You should adopt radiation structure to satisfy the temperature specification.
- (5) Acetic acid type and chlorine type materials for the cover case are not desirable because the former generates corrosive gas of attacking the polarizer at high temperature and the latter causes circuit break by electro-chemical reaction.
- (6) Do not touch, push or rub the exposed polarizers with glass, tweezers or anything harder than HB pencil lead. And please do not rub with dust clothes with chemical treatment.  
Do not touch the surface of polarizer for bare hand or greasy cloth.(Some cosmetics are detrimental to the polarizer.)
- (7) When the surface becomes dusty, please wipe gently with absorbent cotton or other soft materials like chamois soaks with petroleum benzene. Normal-hexane is recommended for cleaning the adhesives used to attach front / rear polarizers. Do not use acetone, toluene and alcohol because they cause chemical damage to the polarizer.
- (8) Wipe off saliva or water drops as soon as possible. Their long time contact with polarizer causes deformations and color fading.
- (9) Do not open the case because inside circuits do not have sufficient strength.

**9-2. OPERATING PRECAUTIONS**

- (1) The spike noise causes the mis-operation of circuits. It should be lower than following voltage :  
 $V = \pm 200\text{mV}$ (Over and under shoot voltage)
- (2) Response time depends on the temperature.(In lower temperature, it becomes longer.)
- (3) Brightness depends on the temperature. (In lower temperature, it becomes lower.)  
And in lower temperature, response time(required time that brightness is stable after turned on) becomes longer.
- (4) Be careful for condensation at sudden temperature change. Condensation makes damage to polarizer or electrical contacted parts. And after fading condensation, smear or spot will occur.
- (5) When fixed patterns are displayed for a long time, remnant image is likely to occur.
- (6) Module has high frequency circuits. Sufficient suppression to the electromagnetic interference shall be done by system manufacturers. Grounding and shielding methods may be important to minimized the interference.





## Product Specification

### 9-3. ELECTROSTATIC DISCHARGE CONTROL

Since a module is composed of electronic circuits, it is not strong to electrostatic discharge. Make certain that treatment persons are connected to ground through wrist band etc. And don't touch interface pin directly.

### 9-4. PRECAUTIONS FOR STRONG LIGHT EXPOSURE

Strong light exposure causes degradation of polarizer and color filter.

### 9-5. STORAGE

When storing modules as spares for a long time, the following precautions are necessary.

- (1) Store them in a dark place. Do not expose the module to sunlight or fluorescent light. Keep the temperature between 5°C and 35°C at normal humidity.
- (2) The polarizer surface should not come in contact with any other object.  
It is recommended that they be stored in the container in which they were shipped.

### 9-6. HANDLING PRECAUTIONS FOR PROTECTION FILM

- (1) When the protection film is peeled off, static electricity is generated between the film and polarizer. This should be peeled off slowly and carefully by people who are electrically grounded and with well ion-blown equipment or in such a condition, etc.
- (2) The protection film is attached to the polarizer with a small amount of glue. If some stress is applied to rub the protection film against the polarizer during the time you peel off the film, the glue is apt to remain on the polarizer.  
Please carefully peel off the protection film without rubbing it against the polarizer.
- (3) When the module with protection film attached is stored for a long time, sometimes there remains a very small amount of glue still on the polarizer after the protection film is peeled off.
- (4) You can remove the glue easily. When the glue remains on the polarizer surface or its vestige is recognized, please wipe them off with absorbent cotton waste or other soft material like chamois soaked with normal-hexane.