

Product Specification

SPECIFICATION FOR APPROVAL

- () Preliminary Specification
(V) Final Specification

Title	15.0" XGA TFT LCD
-------	-------------------

BUYER	DELL
MODEL	P2

SUPPLIER	LG.Philips LCD Co., Ltd.
*MODEL	LP150X09
Suffix	B3

*When you obtain standard approval,
please use the above model name without suffix

SIGNATURE	DATE
/	_____
/	_____
/	_____

Please return 1 copy for your confirmation with your signature and comments.

SIGNATURE	DATE
S.H. Kang / G.Manager	_____
REVIEWED BY	_____
J.H.Lee / Manager	_____
D.J.You / Manager	_____
PREPARED BY	_____
Y.G. Hong / Engineer	_____
C.Park / Engineer	_____

**Products Engineering Dept.
LG. Philips LCD Co., Ltd**

Product Specification

Contents

No	ITEM	Page
	COVER	1
	CONTENTS	2
	RECORD OF REVISIONS	3
1	GENERAL DESCRIPTION	4
2	ABSOLUTE MAXIMUM RATINGS	5
3	ELECTRICAL SPECIFICATIONS	
3-1	ELECTRICAL CHARACTERISTICS	6
3-2	INTERFACE CONNECTIONS	7
3-3	SIGNAL TIMING SPECIFICATIONS	9
3-4	SIGNAL TIMING WAVEFORMS	9
3-5	COLOR INPUT DATA REFERNECE	10
3-6	POWER SEQUENCE	11
4	OPTICAL SFECIFICATIONS	12
5	MECHANICAL CHARACTERISTICS	16
6	RELIABILITY	20
7	INTERNATIONAL STANDARDS	
7-1	SAFETY	21
7-2	EMC	21
8	PACKING	
8-1	DESIGNATION OF LOT MARK	22
8-2	PACKING FORM	22
9	PRECAUTIONS	23
A	APPENDIX. Enhanced Extended Display Identification Data	25

Product Specification

1. General Description

The LP150X09 is a Color Active Matrix Liquid Crystal Display with an integral Cold Cathode Fluorescent Lamp (CCFL) backlight system. The matrix employs a-Si Thin Film Transistor as the active element. It is a transmissive type display operating in the normally white mode. This TFT-LCD has 15.0 inches diagonally measured active display area with XGA resolution(768 vertical by 1024 horizontal pixel array). Each pixel is divided into Red, Green and Blue sub-pixels or dots which are arranged in vertical stripes. Gray scale or the brightness of the sub-pixel color is determined with a 6-bit gray scale signal for each dot, thus, presenting a palette of more than 262,144 colors.

The LP150X09 has been designed to apply the interface method that enables low power, high speed, low EMI.

The LP150X09 is intended to support applications where thin thickness, low power are critical factors and graphic displays are important. In combination with the vertical arrangement of the sub-pixels, the LP150X09 characteristics provide an excellent flat display for office automation products such as Notebook PC.

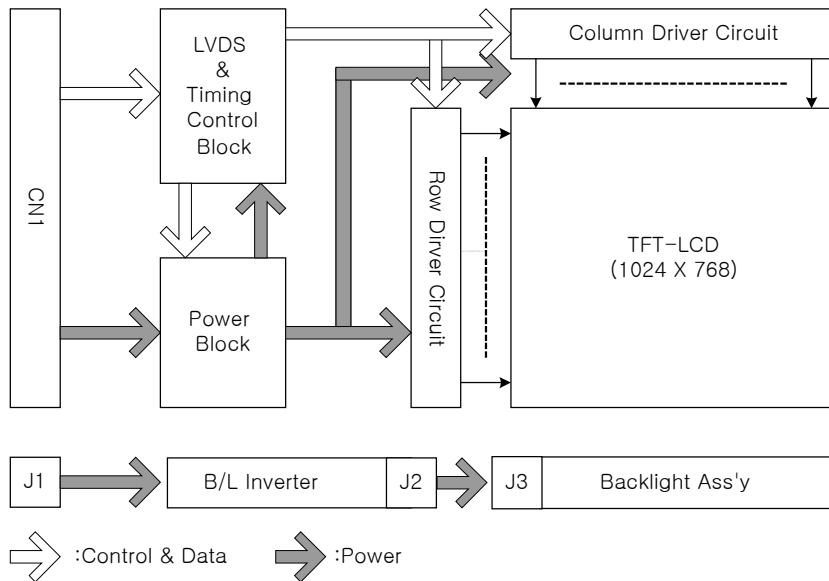

General Features

Active Screen Size	15.0 inches(38.1cm) diagonal
Outline Dimension	317.3(H) × 241.5(V) × 5.7(D) mm (Typ.)
Pixel Pitch	0.297 mm × 0.297 mm
Pixel Format	1024 horiz. By 768 vert. Pixels RGB strip arrangement
Color Depth	6-bit, 262,144 colors
Luminance, White	220 cd/m ² (Typ.), 5p average
Power Consumption	Total 6.22 Watt(Typ.)
Weight	575 g(Max.) with inverter and bracket
Display Operating Mode	Transmissive mode, normally white
Surface Treatment	Hard coating(3H) Anti-glare treatment of the front polarizer

Product Specification

2. Absolute Maximum Ratings

The following are maximum values which, if exceeded, may cause faulty operation or damage to the unit.

Table 1. ABSOLUTE MAXIMUM RATINGS

Parameter	Symbol	Values		Units	Notes
		Min	Max		
Power Input Voltage	VCC	-0.3	4.0	Vdc	at 25 ± 5°C
Operating Temperature	TOP	0	50	°C	1
Storage Temperature	HST	-20	60	°C	1
Operating Ambient Humidity	HOP	10	90	%RH	1
Storage Humidity	HST	10	90	%RH	1

Note : 1. Temperature and relative humidity range are shown in the figure below.
 Wet bulb temperature should be 39°C Max, and no condensation of water.

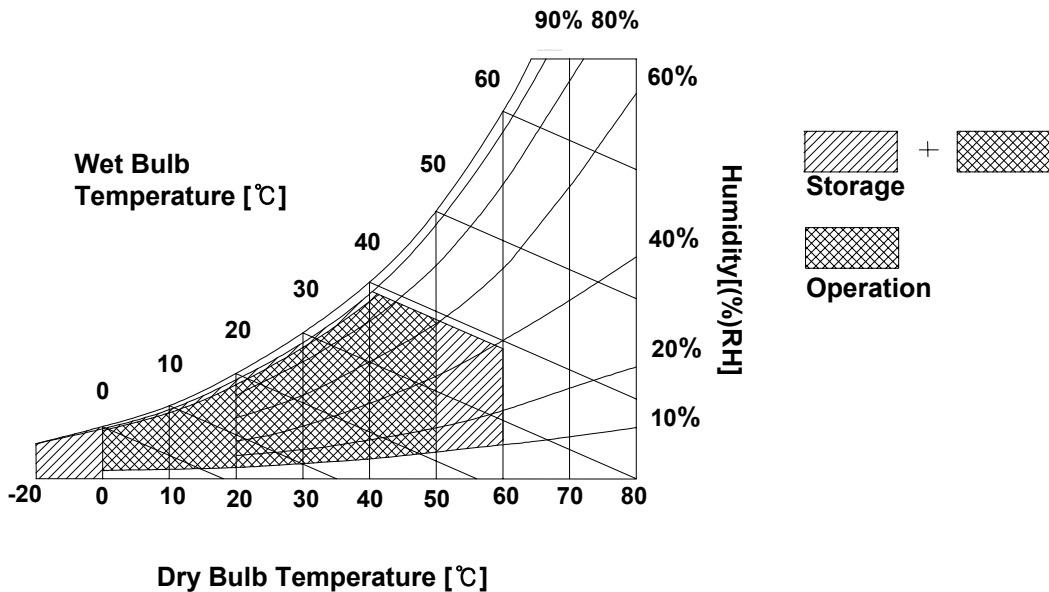

Product Specification

3. Electrical Specifications

3-1. Electrical Characteristics

The LP150X09 requires two power inputs. One is employed to power the LCD electronics and to drive the TFT array and liquid crystal. The second input which powers the CCFL, is typically generated by an inverter. The inverter is an external unit to the LCD.

Table 2. ELECTRICAL CHARACTERISTICS

Parameter	Symbol	Values			Unit	Notes
		Min	Typ	Max		
MODULE :						
Power Supply Input Voltage	VCC	3.0	3.3	3.6	V _{DC}	
Power Supply Input Current	I _{CC}	-	260	300	mA	1
Power Consumption	P _c	-	0.86	1.0	Watt	1
Differential Impedance	Z _m	90	100	110	Ohm	2
LAMP :						
Operating Voltage	V _{BL}	660(6.5mA)	705(5mA)	895(2.0mA)	V _{RMS}	
Operating Current	I _{BL}	2.0	5.0	6.5	mA _{RMS}	3
Operating Frequency	f _{BL}	50	65	80	kHz	
Discharge Stabilization Time	T _s	-	-	3	Min	4
Life Time		10,000	-	-	Hrs	5
INVERTER :						
Input Voltage	V _{IN}	7.5	14.4	21.0	V _{DC}	
Input Current	I _{IN}	-	372	-	mA	6
Input Power Consumption	P _{IN}	-	5.36	-	W	6
Backlight On/Off Control	FPVEE_High	2.0	-	5.25	V _{DC}	
	FPVEE_Low	-0.3	-	0.8	V _{DC}	
Backlight Adjust (I _{BL} Control)		FF	-	00	Hex	
Output Voltage	V _{OUT}	580	680	780	V _{RMS}	7
Output Current (Aging 30minutes)	I _{OUT_FF}	2	-	-	mA _{RMS}	
	I _{OUT_00}	6.0	6.3	6.6	mA _{RMS}	7
Operating Frequency	Freq.	45	-	65	KHz	7
Output Power Consumption	P _{OUT}	3.65	4.28	4.91	W	6
Open Lamp Voltage	V _{OPEN}	1400	-	1800	V _{RMS}	8
Efficiency	η	75	-	-	%	9
Striking Time	T _s	0.6	-	1.4	sec	8

Note)

1. The specified current and power consumption are under the Vcc = 3.3V , 25 °C , fv = 60Hz condition whereas **Mosaic Pattern** is displayed and fv is the frame frequency.
2. This impedance value is needed to proper display and measured form LVDS Tx to the mating connector.
3. The typical operating current is for the typical surface luminance (L_{WH}) in optical characteristics.

Product Specification

Note)

4. Define the brightness of the lamp after being lighted for 5 minutes as 100%, T_s is the time required for the brightness of the center of the lamp to be not less than 95%.
5. The life time is determined as the time at which brightness of lamp is 50% compare to that of initial value at the typical lamp current.
6. $V_{IN} = 14.4V(Typ.)$, 00_H
7. SMDData=00_H
8. No Load, SMDData=00_H.
9. $V_{IN} = 7.5V(Min.)$, 00H.

3-2. Interface Connections

This LCD employs two interface connections, a 30 pin connector is used for the module electronics interface and the other connector is used for the integral backlight system.

The electronics interface connector is a model FI-XB30SRL-HF11 manufactured by JAE.

Table 3. MODULE CONNECTOR PIN CONFIGURATION (CN1)

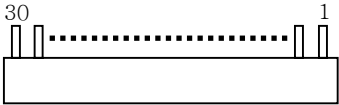
Pin	Symbol	Description	Notes
1	GND	Ground	<p>1. Interface chips 1.1 LCD : LPZ4E102S6L(LCD Controller) including LVDS Receiver 1.2 System : THC63LVDF823A or equivalent * Pin to Pin compatible with TI LVDS</p> <p>2. Connector 2.1 LCD : FI-XB30SRL-HF11, JAE 2.2 Mating : FI-X30M or equivalent. 2.3 Connector pin arrangement</p>  <p>[LCD Module Rear View]</p>
2	VCC	Power Supply, 3.3V Typ.	
3	VCC	Power Supply, 3.3V Typ.	
4	V EEDID	DDC 3.3V power	
5	NC	Reserved for supplier test point	
6	Clk EEDID	DDC Clock	
7	DATA EEDID	DDC Data	
8	$R_{IN, 0-}$	Negative LVDS differential data input	
9	$R_{IN, 0+}$	Positive LVDS differential data input	
10	GND	Ground	
11	$R_{IN, 1-}$	Negative LVDS differential data input	
12	$R_{IN, 1+}$	Positive LVDS differential data input	
13	GND	Ground	
14	$R_{IN, 2-}$	Negative LVDS differential data input	
15	$R_{IN, 2+}$	Positive LVDS differential data input	
16	GND	Ground	
17	CLKIN-	Negative LVDS differential clock input	
18	CLKIN+	Positive LVDS differential clock input	
19	GND	Ground	
20	NC	No connection	
21	NC	No connection	
22	GND	Ground	
23	NC	No connection	
24	NC	No connection	
25	GND	Ground	
26	NC	No connection	
27	NC	No connection	
28	GND	Ground	
29	NC	No connection	
30	NC	No connection	

Product Specification

The inverter interface connector(J1) is a LVC-D20SFYG model manufactured by Honda. The pin configuration for the connector is shown in the table below.

Table 4. BACKLIGHT INVERTER CONNECTOR PIN CONFIGURATION (J1)

Pin	Symbol	Description	Notes
1	V _{IN}	Power for the inverter	[Connector] LVC-D20SFYG, Honda [Connector pin arrangement]
2	V _{IN}	Power for the inverter	
3	V _{IN}	Power for the inverter	
4	NC	No connection	
5	GND	Ground	
6	5V_SUS	Power for the control circuit	
7	5V_ALW	Power for storing a brightness values	
8	GND	Ground	
9	SMB_DAT	Brightness data	
10	SMB_CLK	Clock for brightness data	
11	GND	Ground	
12	FPVEE	Enable for lamp turn on and off	
13	GND	Ground	
14	LAMP_STAT	Lamp status (Feedback, Lamp On = 5V, Lamp Off 0V), from control chip	
15~20	NC	No Connection	

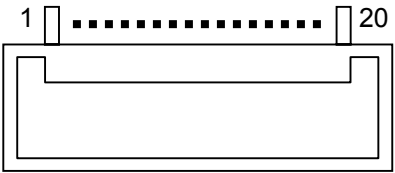

The backlight interface connector is a model BHSR-02VS-1, manufactured by JST or a model 1376176-1, manufactured by AMP. The mating connector part number is SM02B-BHSS-1 or equivalent.

Table 5. BACKLIGHT CONNECTOR PIN CONFIGURATION (J3)

Pin	Symbol	Description	Notes
1	HV	Power supply for lamp (High voltage side)	1
2	LV	Power supply for lamp (Low voltage side)	1

Notes : 1. The high voltage side terminal is colored pink and the low voltage side terminal is white

Product Specification

3-3. Signal Timing Specifications

This is the signal timing required at the input of the User connector. All of the interface signal timing should be satisfied with the following specifications and specifications of LVDS Tx/Rx for its proper operation.

Table 6. TIMING TABLE

ITEM	Symbol		Min	Typ	Max	Unit	Note
DCLK	Frequency	fCLK	62	65	68	MHz	15.4ns
Hsync	Period	tHP	1206	1344	1364	tCLK	
	Width	tWH	8	-	-		
Vsync	Period	tVP	780	806	830	tHP	
	Width	tWV	2	-	-		
Data Enable	Horizontal back porch	tHBP	16	-	-	tCLK	
	Horizontal front porch	tHFP	16	-	-		
	Vertical back porch	tVBP	7	-	-	tHP	
	Vertical front porch	tVFP	2	-	-		

3-4. Signal Timing Waveforms

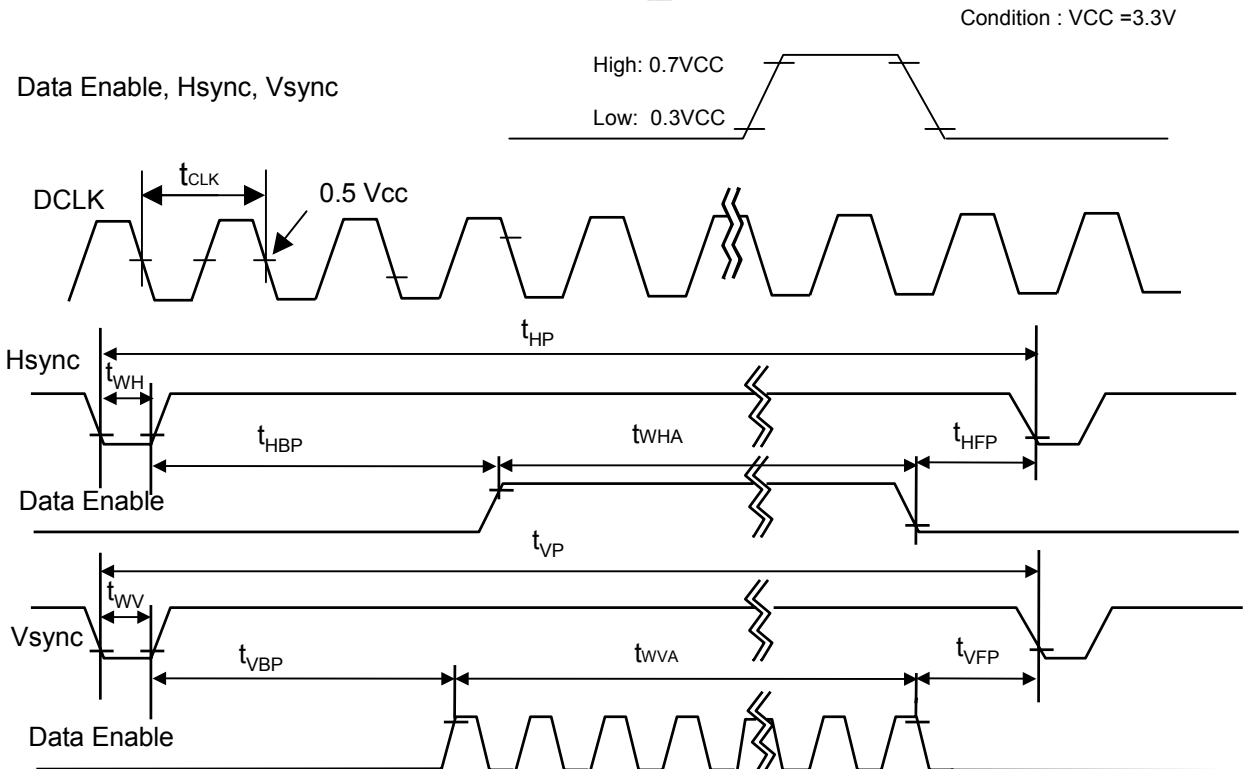

Product Specification

3-5. Color Input Data Reference

The brightness of each primary color (red, green and blue) is based on the 6-bit gray scale data input for the color ; the higher the binary input, the brighter the color. The table below provides a reference for color versus data input.

Table 7. COLOR DATA REFERENCE

Color		Input Color Data																	
		RED						GREEN						BLUE					
		MSB			LSB			MSB			LSB			MSB			LSB		
		R5	R4	R3	R2	R1	R0	G5	G4	G3	G2	G1	G0	B5	B4	B3	B2	B1	B0
Basic Color	Black	0	0	0	0	0	0	0	0	0	0	0	0	0	0	0	0	0	0
	Red	1	1	1	1	1	1	0	0	0	0	0	0	0	0	0	0	0	0
	Green	0	0	0	0	0	0	1	1	1	1	1	1	0	0	0	0	0	0
	Blue	0	0	0	0	0	0	0	0	0	0	0	0	1	1	1	1	1	1
	Cyan	0	0	0	0	0	0	1	1	1	1	1	1	1	1	1	1	1	1
	Magenta	1	1	1	1	1	1	0	0	0	0	0	0	1	1	1	1	1	1
	Yellow	1	1	1	1	1	1	1	1	1	1	1	1	0	0	0	0	0	0
	White	1	1	1	1	1	1	1	1	1	1	1	1	1	1	1	1	1	1
RED	RED (00)	0	0	0	0	0	0	0	0	0	0	0	0	0	0	0	0	0	0
	RED (01)	0	0	0	0	0	1	0	0	0	0	0	0	0	0	0	0	0	0
					
	RED (62)	1	1	1	1	1	0	0	0	0	0	0	0	0	0	0	0	0	0
	RED (63)	1	1	1	1	1	1	0	0	0	0	0	0	0	0	0	0	0	0
GREEN	GREEN (00)	0	0	0	0	0	0	0	0	0	0	0	0	0	0	0	0	0	0
	GREEN (01)	0	0	0	0	0	0	0	0	0	0	0	1	0	0	0	0	0	0
					
	GREEN (62)	0	0	0	0	0	0	1	1	1	1	1	0	0	0	0	0	0	0
	GREEN (63)	0	0	0	0	0	0	1	1	1	1	1	1	0	0	0	0	0	0
BLUE	BLUE (00)	0	0	0	0	0	0	0	0	0	0	0	0	0	0	0	0	0	0
	BLUE (01)	0	0	0	0	0	0	0	0	0	0	0	0	0	0	0	0	0	1
					
	BLUE (62)	0	0	0	0	0	0	0	0	0	0	0	0	1	1	1	1	1	0
	BLUE (63)	0	0	0	0	0	0	0	0	0	0	0	0	1	1	1	1	1	1

Product Specification

3-6. Power Sequence

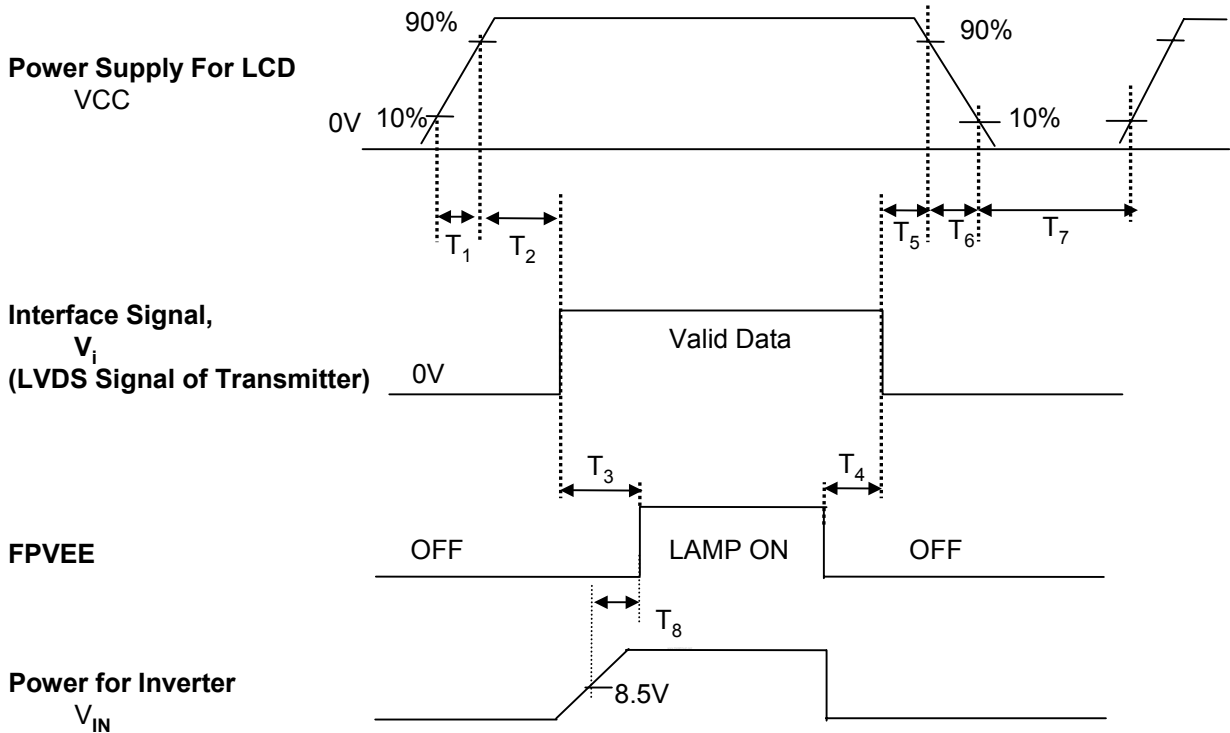

Table 8. POWER SEQUENCE TABLE

Parameter	Value			Units
	Min.	Typ.	Max.	
T ₁	-	-	10	(ms)
T ₂	0	-	50	(ms)
T ₃	200	-	-	(ms)
T ₄	0	-	-	(ms)
T ₅	0	-	50	(ms)
T ₆	0	-	10	(ms)
T ₇	400	-	-	(ms)
T ₈	10	-	-	(ms)

Note)

1. Please avoid floating state of interface signal at invalid period.
2. When the interface signal is invalid, be sure to pull down the power supply for LCD VCC to 0V.
3. Lamp power must be turn on after power supply for LCD and interface signal are valid.

Product Specification

4. Optical Specification

Optical characteristics are determined after the unit has been 'ON' and stable for approximately 30 minutes in a dark environment at 25°C. The values specified are at an approximate distance 50cm from the LCD surface at a viewing angle of Φ and Θ equal to 0°.

FIG. 1 presents additional information concerning the measurement equipment and method.

FIG. 1 Optical Characteristic Measurement Equipment and Method

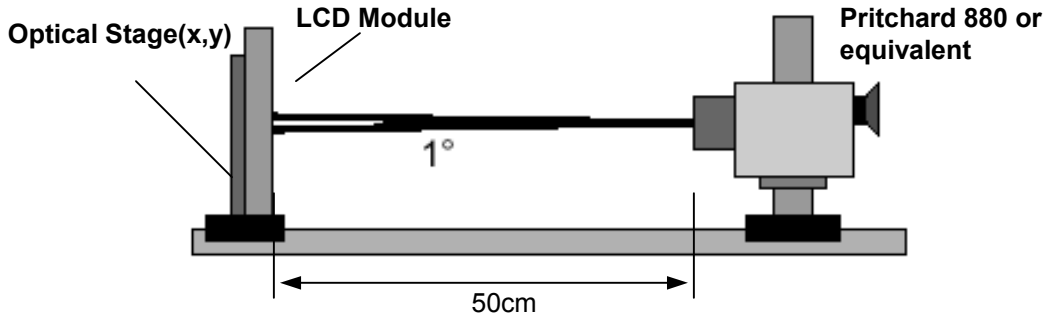

Table 9. OPTICAL CHARACTERISTICS

Ta=25°C, VCC=3.3V, fv=60Hz, fCLK= 65MHz, Iout = 6.3mA(SMB-DAT=00H)

Parameter	Symbol	Values			Units	Notes
		Min	Typ	MAx		
Contrast Ratio	CR	350	-	-		1
Surface Luminance, white	L _{WH}	200	220	-	cd/m ²	2
Luminance Variation	δ_{WHITE}	-	-	50	%	3
Response Time	Tr(Tr _R +Tr _D)	-	30	40	ms	4
Color Coordinates						
RED	RX	0.562	0.587	0.612		
	RY	0.318	0.343	0.368		
GREEN	GX	0.296	0.321	0.346		
	GY	0.505	0.530	0.555		
BLUE	BX	0.134	0.159	0.184		
	BY	0.115	0.140	0.165		
WHITE	WX	0.283	0.313	0.343		
	WY	0.299	0.329	0.359		
Viewing Angle						5
x axis, right($\Phi=0^\circ$)	Θ_r	-	45	-	degree	
x axis, left ($\Phi=180^\circ$)	Θ_l	-	45	-	degree	
y axis, up ($\Phi=90^\circ$)	Θ_u	-	15	-	degree	
y axis, down ($\Phi=270^\circ$)	Θ_d	-	35	-	degree	
Gray Scale			2.2			6

Product Specification

Note)

1. Contrast Ratio(CR) is defined mathematically as

$$\text{Contrast Ratio} = \frac{\text{Surface Luminance with all white pixels}}{\text{Surface Luminance with all black pixels}}$$

2. Surface luminance is the average of 5 point across the LCD surface 50cm from the surface with all pixels displaying white. For more information see FIG 1.

$$L_{WH} = \text{Average}(L_4, L_5, L_7, L_9, L_{10})$$

3. The variation in surface luminance , The panel total variation (δ_{WHITE}) is determined by measuring L_N at each test position 1 through 13 and then defined as followed numerical formula.
 For more information see FIG 2.

$$\delta_{WHITE} = \frac{\text{Maximum}(L_1, L_2, \dots L_{13}) - \text{Minimum}(L_1, L_2, \dots L_{13})}{\text{Maximum}(L_1, L_2, \dots L_{13})} \times 100$$

4. Response time is the time required for the display to transition from white to black (rise time, Tr_R) and from black to white(Decay Time, Tr_D). For additional information see FIG 3.

5. Viewing angle is the angle at which the contrast ratio is greater than 10. The angles are determined for the horizontal or x axis and the vertical or y axis with respect to the z axis which is normal to the LCD surface. For more information see FIG 4.

6. Gray scale specification

* $f_v=60\text{Hz}$

Gray Level	Luminance [%] (Typ)
L0	0.15
L7	0.80
L15	4.25
L23	10.90
L31	21.0
L39	34.8
L47	52.5
L55	74.2
L63	100

Product Specification

FIG. 2 Luminance

<measuring point for surface luminance & measuring point for luminance variation>

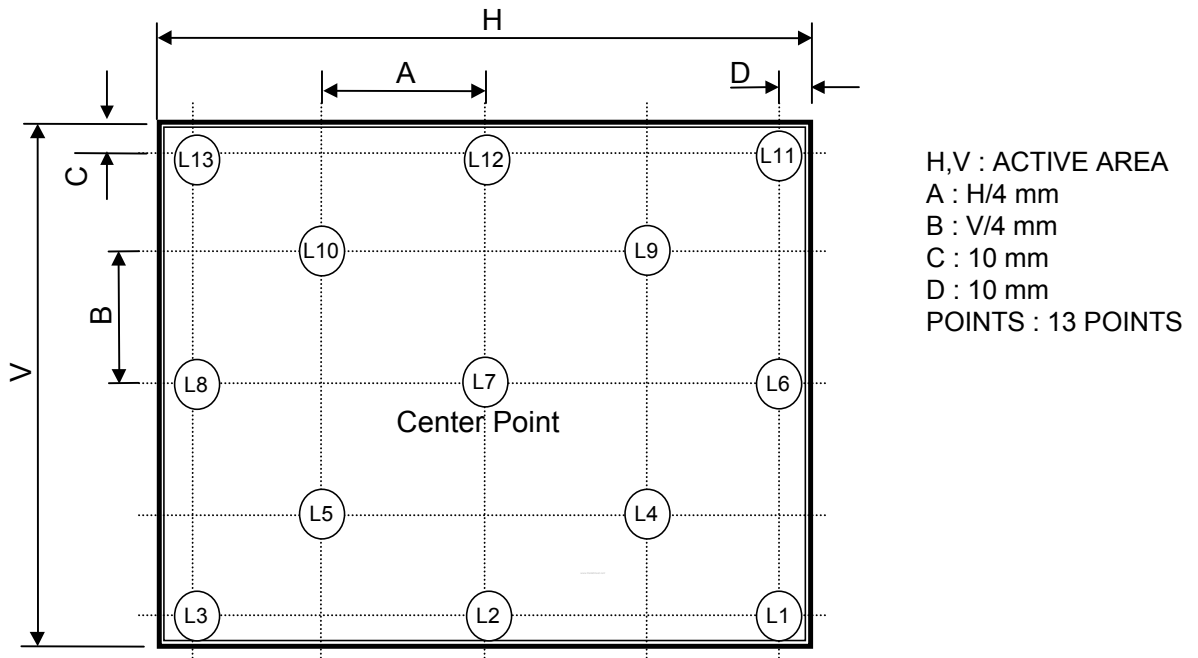
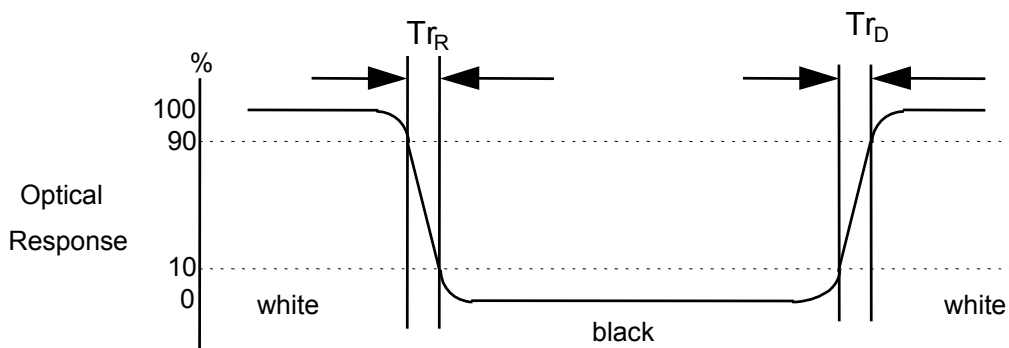

FIG. 3 Response Time

The response time is defined as the following figure and shall be measured by switching the input signal for “black” and “white”.



Product Specification

FIG. 4 Viewing angle

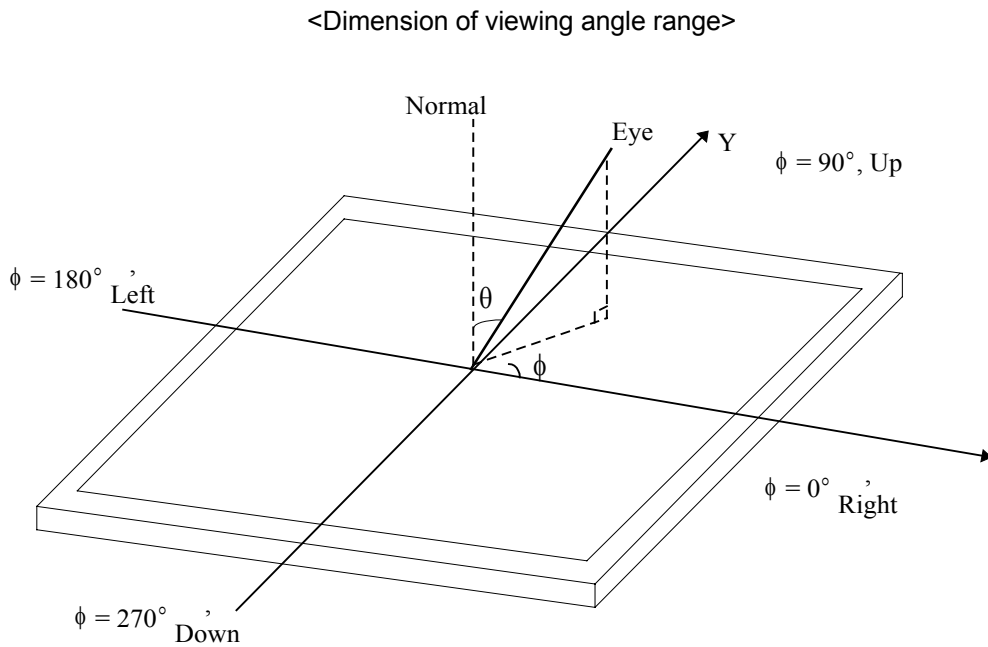

Product Specification

5. Mechanical Characteristics

The contents provide general mechanical characteristics for the model LP150X09. In addition the figures in the next page are detailed mechanical drawing of the LCD.

Outline Dimension	Horizontal	317.3 ± 0.5mm
	Vertical	241.5 ± 0.5mm
	Depth	5.7 mm(Typ.) 6.0mm(Max.)
Bezel Area	Horizontal	307.5 ± 0.5mm
	Vertical	231.4 ± 0.5mm
Active Display Area	Horizontal	304.128 mm
	Vertical	228.096 mm
Weight	575g (Max.) with inverter & bracket	
Surface Treatment	Hard coating(3H) Anti-glare treatment of the front polarizer	

Product Specification

<FRONT VIEW>

Note) Unit:[mm], General tolerance: ± 0.5 mm

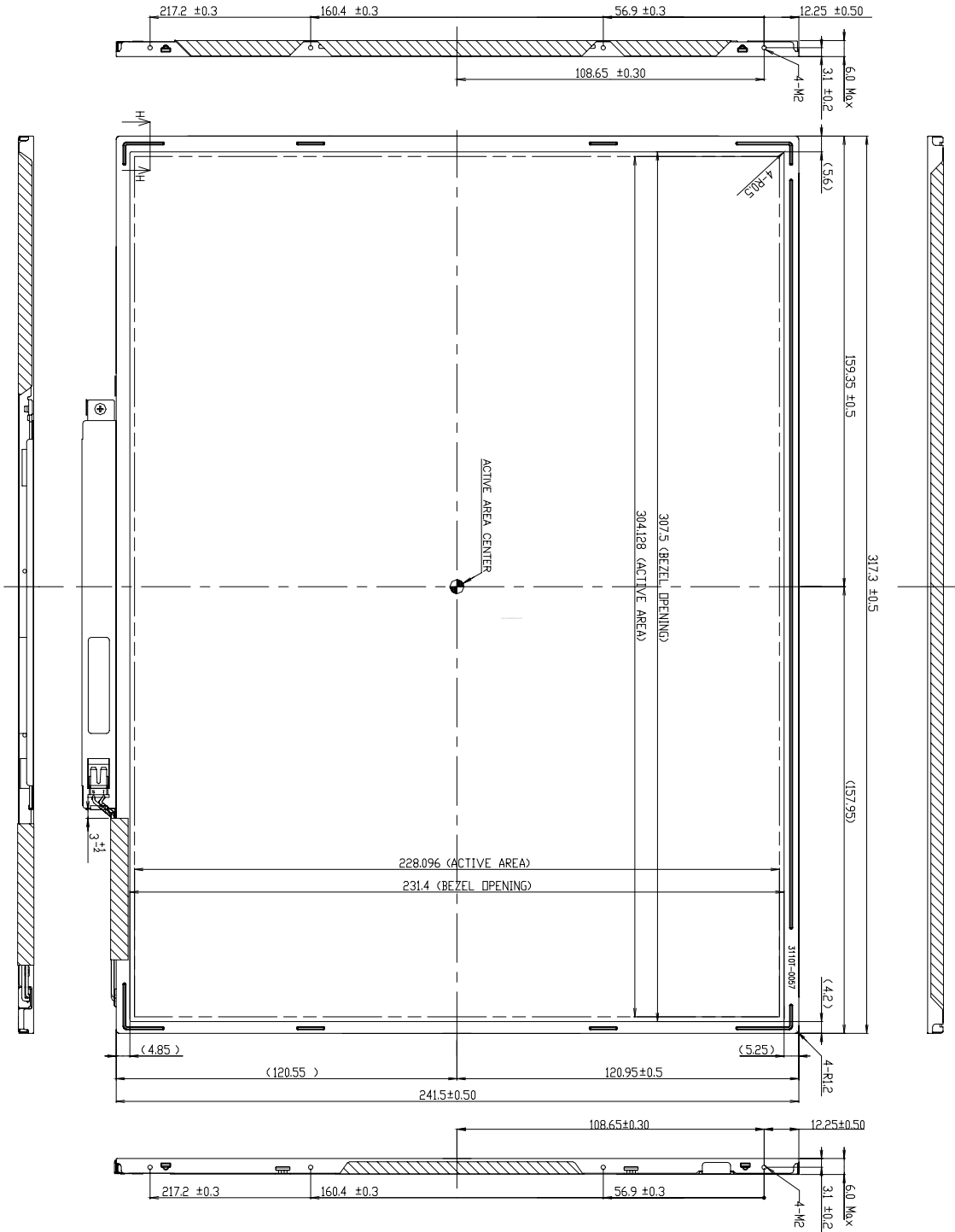

Product Specification

<REAR VIEW>

Note) Unit:[mm], General tolerance: $\pm 0.5\text{mm}$

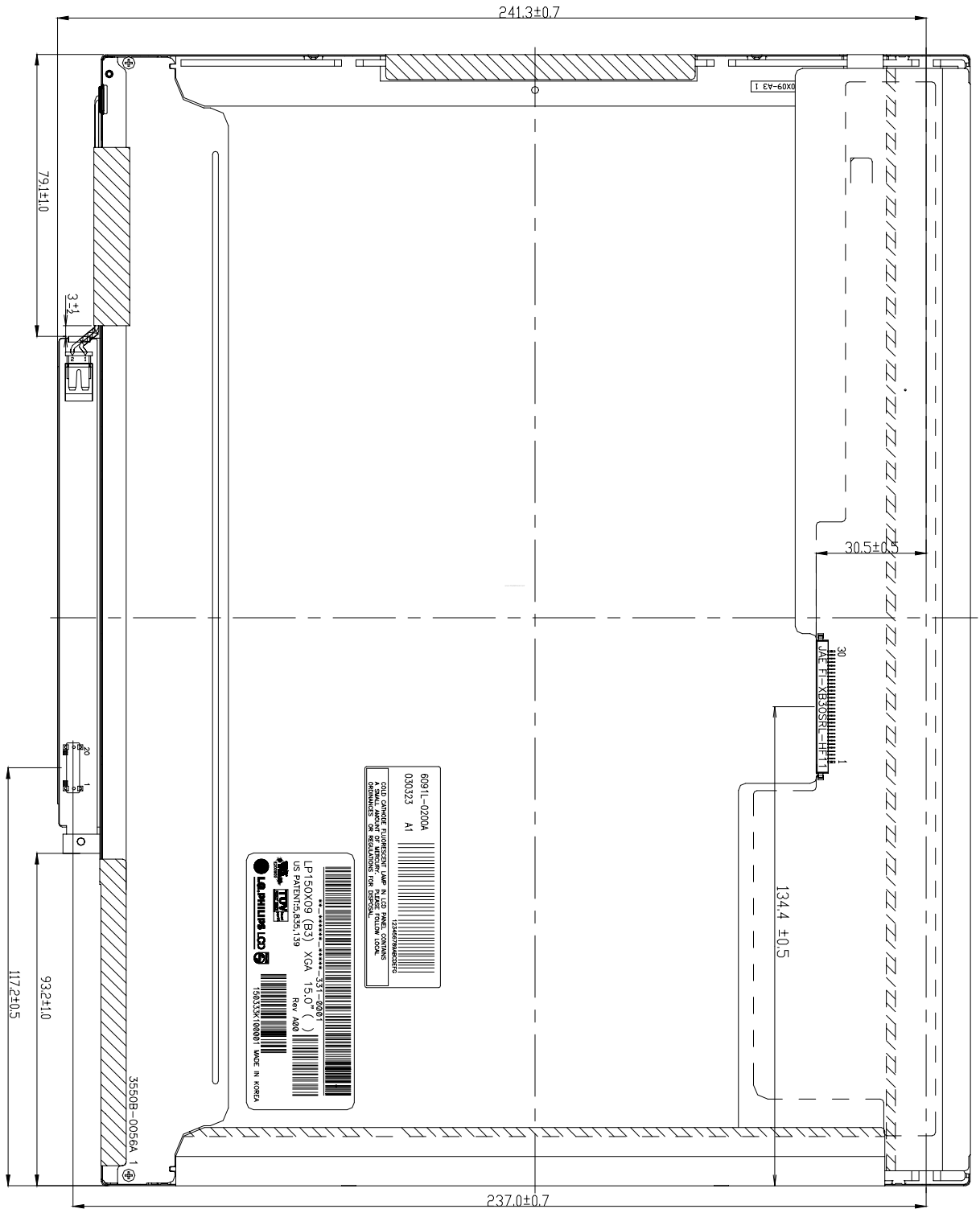

Product Specification

6. Reliability

Environment test condition

No.	Test Item	Conditions
1	High temperature storage test	Ta= 60°C, 240h
2	Low temperature storage test	Ta= -20°C, 240h
3	High temperature operation test	Ta= 50°C, 50%RH, 240h
4	Low temperature operation test	Ta= 0°C, 240h
5	Vibration test (non-operating)	Sine wave, 10 ~ 500 ~ 10Hz, 1.5G, 0.37oct/min 3 axis, 1hour/axis
6	Shock test (non-operating)	Half sine wave, 180G, 2ms one shock of each six faces(I.e. run 180G 2ms for all six faces)
7	Altitude operating storage / shipment	0 ~ 10,000 feet (3,048m) 24Hr 0 ~ 40,000 feet (12,192m) 24Hr

{ Result Evaluation Criteria }

There should be no change which might affect the practical display function when the display quality test is conducted under normal operating condition.

Product Specification**7. International Standards****7-1. Safety**

- a) UL 60950, Third Edition, Underwriters Laboratories, Inc., Dated Dec. 11, 2000.
Standard for Safety of Information Technology Equipment, Including Electrical Business Equipment.
- b) CAN/CSA C22.2, No. 60950, Third Edition, Canadian Standards Association, Dec. 1, 2000.
Standard for Safety of Information Technology Equipment, Including Electrical Business Equipment.
- c) EN 60950 : 2000, Third Edition
IEC 60950 : 1999, Third Edition
European Committee for Electrotechnical Standardization(CENELEC)
EUROPEAN STANDARD for Safety of Information Technology Equipment Including Electrical Business Equipment.

7-2. EMC

- a) ANSI C63.4 "Methods of Measurement of Radio-Noise Emissions from Low-Voltage Electrical and Electrical Equipment in the Range of 9kHz to 40GHz. "American National Standards Institute(ANSI), 1992
- b) C.I.S.P.R "Limits and Methods of Measurement of Radio Interface Characteristics of Information Technology Equipment." International Special Committee on Radio Interference.
- c) EN 55022 "Limits and Methods of Measurement of Radio Interface Characteristics of Information Technology Equipment." European Committee for Electrotechnical Standardization.(CENELEC), 1998 (Including A1: 2000)

Product Specification

8. Packing

8-1. Designation of Lot Mark

a) Lot Mark

A	B	C	D	E	F	G	H	I	J	K	L	M
---	---	---	---	---	---	---	---	---	---	---	---	---

A,B,C : Inch
 D : Year
 E : Month
 F : Panel Code
 G : Factory Code
 H : Assembly Code
 I,J,K,L,M : Serial No

Note

1. Year

Year	97	98	99	2000	2001	2002	2003	2004	2005	2006	2007
Mark	7	8	9	0	1	2	3	4	5	6	7

2. Month

Month	Jan	Feb	Mar	Apr	May	Jun	Jul	Aug	Sep	Oct	Nov	Dec
Mark	1	2	4	4	5	6	7	8	9	A	B	C

3. Panel Code

Panel Code	P1 Factory	P2 Factory	P3 Factory	P4 Factory	P5 Factory	Hydis Panel
Mark	1	2	3	4	5	H

4. Factory Code

Factory Code	LPL Gumi	LPL Nanjing
Mark	K	C

5. Serial No

Serial No.	1 ~ 99,999	100,000 ~
Mark	00001 ~ 99999	A0001 ~ A9999, - - - - , Z9999

b) Location of Lot Mark

Serial NO. is printed on the label. The label is attached to the backside of the LCD module.
 This is subject to change without prior notice.

8-2. Packing Form

- a) Package quantity in one box : 10 pcs
- b) Box Size : 372mm × 317mm × 308mm

Product Specification

9. PRECAUTIONS

Please pay attention to the followings when you use this TFT LCD module.

9-1. MOUNTING PRECAUTIONS

- (1) You must mount a module using holes arranged in four corners or four sides.
- (2) You should consider the mounting structure so that uneven force (ex. Twisted stress) is not applied to the module. And the case on which a module is mounted should have sufficient strength so that external force is not transmitted directly to the module.
- (3) Please attach the surface transparent protective plate to the surface in order to protect the polarizer. Transparent protective plate should have sufficient strength in order to resist external force.
- (4) You should adopt radiation structure to satisfy the temperature specification.
- (5) Acetic acid type and chlorine type materials for the cover case are not desirable because the former generates corrosive gas of attacking the polarizer at high temperature and the latter causes circuit break by electro-chemical reaction.
- (6) Do not touch, push or rub the exposed polarizer with glass, tweezers or anything harder than HB pencil lead. And please do not rub with dust clothes with chemical treatment. Do not touch the surface of polarizer for bare hand or greasy cloth.(Some cosmetics are detrimental to the polarizer.)
- (7) When the surface becomes dusty, please wipe gently with absorbent cotton or other soft materials like chamois soaks with petroleum benzene. Normal-hexane is recommended for cleaning the adhesives used to attach front / rear polarizer. Do not use acetone, toluene and alcohol because they cause chemical damage to the polarizer.
- (8) Wipe off saliva or water drops as soon as possible. Their long time contact with polarizer causes deformations and color fading.
- (9) Do not open the case because inside circuits do not have sufficient strength.

9-2. OPERATING PRECAUTIONS

- (1) The spike noise causes the mis-operation of circuits. It should be lower than following voltage :
 $V = \pm 200\text{mV}$ (Over and under shoot voltage)
- (2) Response time depends on the temperature.(In lower temperature, it becomes longer.)
- (3) Brightness depends on the temperature. (In lower temperature, it becomes lower.)
And in lower temperature, response time(required time that brightness is stable after turned on) becomes longer.
- (4) Be careful for condensation at sudden temperature change. Condensation makes damage to polarizer or electrical contacted parts. And after fading condensation, smear or spot will occur.
- (5) When fixed patterns are displayed for a long time, remnant image is likely to occur.
- (6) Module has high frequency circuits. Sufficient suppression to the electromagnetic interference shall be done by system manufacturers. Grounding and shielding methods may be important to minimize the interference.

Product Specification

9-3. ELECTROSTATIC DISCHARGE CONTROL

Since a module is composed of electronic circuits, it is not strong to electrostatic discharge. Make certain that treatment persons are connected to ground through wrist band etc. And don't touch interface pin directly.

9-4. PRECAUTIONS FOR STRONG LIGHT EXPOSURE

Strong light exposure causes degradation of polarizer and color filter.

9-5. STORAGE

When storing modules as spares for a long time, the following precautions are necessary.

- (1) Store them in a dark place. Do not expose the module to sunlight or fluorescent light. Keep the temperature between 5°C and 35°C at normal humidity.
- (2) The polarizer surface should not come in contact with any other object.
It is recommended that they be stored in the container in which they were shipped.

9-6. HANDLING PRECAUTIONS FOR PROTECTION FILM

- (1) The protection film is attached to the bezel with a small masking tape.
When the protection film is peeled off, static electricity is generated between the film and polarizer. This should be peeled off slowly and carefully by people who are electrically grounded and with well ion-blown equipment or in such a condition, etc.
- (2) When the module with protection film attached is stored for a long time, sometimes there remains a very small amount of glue still on the bezel after the protection film is peeled off.
- (3) You can remove the glue easily. When the glue remains on the bezel surface or its vestige is recognized, please wipe them off with absorbent cotton waste or other soft material like chamois soaked with normal-hexane.

Product Specification

APPENDIX A. Enhanced Extended Display Identification Data (EEDID™) 1/3

Byte# (decimal)	Byte# (HEX)	Field Name and Comments	Value (HEX)		Value (binary)		
0	00	Header	0	0	0000	0000	Header
1	01	Header	F	F	1111	1111	
2	02	Header	F	F	1111	1111	
3	03	Header	F	F	1111	1111	
4	04	Header	F	F	1111	1111	
5	05	Header	F	F	1111	1111	
6	06	Header	F	F	1111	1111	
7	07	Header	0	0	0000	0000	
8	08	EISA manufacturer code(3 Character ID) = "LGP"	3	0	0011	0000	Vendor/ Product ID
9	09	Compressed ASCII	F	0	1111	0000	
10	0A	Panel Supplier Reserved - Product code = 159 (LP150X09)	0	0	0000	0000	
11	0B	(Hex, LSB first)	0	0	0000	0000	
12	0C	LCD Module Serial No. = 0 (If not used)	0	0	0000	0000	
13	0D	LCD Module Serial No. = 0 (If not used)	0	0	0000	0000	
14	0E	LCD Module Serial No. = 0 (If not used)	0	0	0000	0000	
15	0F	LCD Module Serial No. = 0 (If not used)	0	0	0000	0000	
16	10	Week of Manufacture = 00	0	0	0000	0000	
17	11	Year of Manufacture = "2003"	0	D	0000	1101	
18	12	EDID Structure version # = "1"	0	1	0000	0001	EDID Version/ Revision
19	13	EDID Revision # = "3"	0	3	0000	0011	
20	14	Video Input Definition = Digital I/P, non TMDS CRGB	8	0	1000	0000	Display Parameter
21	15	Max H image size(cm)=30.4128cm(30)	1	E	0001	1110	
22	16	Max V image size(cm)=22.8096cm(22)	1	7	0001	0111	
23	17	Display gamma = "2.2"	7	8	0111	1000	
24	18	Feature support(DPMS) = Active off, RGB Color	0	A	0000	1010	
25	19	Red/Green low Bits	0	8	0111	0110	Color Characteristic
26	1A	Blue/White Low Bits	2	0	1100	0000	
27	1B	Red X Rx = 0.590	9	7	1001	0010	
28	1C	Red Y Ry = 0.340	5	7	0101	0101	
29	1D	Green X Gx = 0.323	5	2	0101	0001	
30	1E	Green Y Gy = 0.532	8	8	1000	1001	
31	1F	Blue X Bx = 0.157	2	8	0010	0111	
32	20	Blue Y By = 0.135	2	2	0010	0010	
33	21	White X Wx = 0.313	5	0	0101	0000	Established Timings
34	22	White Y Wy = 0.329	5	4	0101	0100	
35	23	Established Timing I = 00h(If not used)	0	0	0000	0000	
36	24	Established Timing II = 00h(If not used)	0	0	0000	0000	
37	25	Manufacturer's Timings = 00h(If not used)	0	0	0000	0000	
38	26	Standard Timing Identification 1 was not used	0	1	0000	0001	
39	27	Standard Timing Identification 1 was not used	0	1	0000	0001	
40	28	Standard Timing Identification 2 was not used	0	1	0000	0001	
41	29	Standard Timing Identification 2 was not used	0	1	0000	0001	
42	2A	Standard Timing Identification 3 was not used	0	1	0000	0001	
43	2B	Standard Timing Identification 3 was not used	0	1	0000	0001	
44	2C	Standard Timing Identification 4 was not used	0	1	0000	0001	
45	2D	Standard Timing Identification 4 was not used	0	1	0000	0001	
46	2E	Standard Timing Identification 5 was not used	0	1	0000	0001	
47	2F	Standard Timing Identification 5 was not used	0	1	0000	0001	
48	30	Standard Timing Identification 6 was not used	0	1	0000	0001	
49	31	Standard Timing Identification 6 was not used	0	1	0000	0001	
50	32	Standard Timing Identification 7 was not used	0	1	0000	0001	
51	33	Standard Timing Identification 7 was not used	0	1	0000	0001	
52	34	Standard Timing Identification 8 was not used	0	1	0000	0001	
53	35	Standard Timing Identification 8 was not used	0	1	0000	0001	

Product Specification

APPENDIX A. Enhanced Extended Display Identification Data (EEDID™) 2/3

Byte# (decimal)	Byte# (HEX)	Field Name and Comments	Value (HEX)	Value (binary)		
54	36	Pixel Clock/10,000 (LSB)	6 4	0110 0100	Detailed Timing Description #1	
55	37	Pixel Clock/10,000 (MSB) / 1024 x 768 @ 60Hz pixel clock = 65.00MHz	1 9	0001 1001		
56	38	Horizontal Active = 1024 pixels	0 0	0000 0000		
57	39	Horizontal Blanking = 320 pixels	4 0	0100 0000		
58	3A	Horizontal Active : Horizontal Blanking	4 1	0100 0001		
59	3B	Vertical Active = 768 lines	0 0	0000 0000		
60	3C	Vertical Blanking = 38 lines	2 6	0010 0110		
61	3D	Vertical Active : Vertical Blanking	3 0	0011 0000		
62	3E	Horizontal Sync. Offset = 24 pixels	1 8	0001 1000		
63	3F	Horizontal Sync Pulse Width = 136 pixels	8 8	1000 1000		
64	40	Vertical Sync Offset = 3 lines : Sync Width = 6 lines	3 6	0011 0110		
65	41	Horizontal Vertical Sync Offset/Width upper 2bits = 0	0 0	0000 0000		
66	42	Horizontal Image Size = 304.128 mm(304)	3 0	0011 0000		
67	43	Vertical Image Size = 228.096 mm(228)	E 4	1110 0100		
68	44	Horizontal & Vertical Image Size	1 0	0001 0000		
69	45	Horizontal Border = 0	0 0	0000 0000		
70	46	Vertical Border = 0	0 0	0000 0000		
71	47	Non-interlaced,Normal display,no stereo,Digital separate sync,H/V pol negatives	1 8	0001 1000		
72	48	Pixel Clock/10,000 (LSB)	6 4	0110 0100		Detailed Timing Description #2
73	49	Pixel Clock/10,000 (MSB) / 1024 x 768 @ 60Hz pixel clock = 65.00MHz	1 9	0001 1001		
74	4A	Horizontal Active = 1024 pixels	0 0	0000 0000		
75	4B	Horizontal Blanking = 320 pixels	4 0	0100 0000		
76	4C	Horizontal Active : Horizontal Blanking	4 1	0100 0001		
77	4D	Vertical Active = 768 lines	0 0	0000 0000		
78	4E	Vertical Blanking = 38 lines	2 6	0010 0110		
79	4F	Vertical Active : Vertical Blanking	3 0	0011 0000		
80	50	Horizontal Sync. Offset = 24 pixels	1 8	0001 1000		
81	51	Horizontal Sync Pulse Width = 136 pixels	8 8	1000 1000		
82	52	Vertical Sync Offset = 3 lines : Sync Width = 6 lines	3 6	0011 0110		
83	53	Horizontal Vertical Sync Offset/Width upper 2bits = 0	0 0	0000 0000		
84	54	Horizontal Image Size = 304.128 mm(304)	3 0	0011 0000		
85	55	Vertical Image Size = 228.096 mm(228)	E 4	1110 0100		
86	56	Horizontal & Vertical Image Size	1 0	0001 0000		
87	57	Horizontal Border = 0	0 0	0000 0000		
88	58	Vertical Border = 0	0 0	0000 0000		
89	59	Module "A" Revision (Example : 00, 01, 02, 03, etc.) = 00	0 0	0000 0000		
90	5A	Flag	0 0	0000 0000	Detailed Timing Description #3	
91	5B	Flag	0 0	0000 0000		
92	5C	Flag	0 0	0000 0000		
93	5D	Dummy Descriptor	0 0	0000 0000		
94	5E	Flag	0 0	0000 0000		
95	5F	Dell P/N 1 st Character = "F"	4 6	0000 0000		
96	60	Dell P/N 2 nd Character = "1"	3 1	0000 0000		
97	61	Dell P/N 3 rd Character = "1"	3 1	0000 0000		
98	62	Dell P/N 4 th Character = "2"	3 2	0000 0000		
99	63	Dell P/N 5 th Character = "4"	3 4	0000 0000		
100	64	LCD Supplier EEDID Revision # = 0	0 0	0000 0000		
101	65	Manufacturer P/N = "1"	3 1	0011 0001		
102	66	Manufacturer P/N = "5"	3 5	0011 0101		
103	67	Manufacturer P/N = "0"	3 0	0011 0000		
104	68	Manufacturer P/N = "X"	5 8	0101 1000		
105	69	Manufacturer P/N = "0"	3 0	0011 0000		
106	6A	Manufacturer P/N = "9"	3 9	0011 1001		
107	6B	Manufacturer P/N(If <13 char, then terminate with ASCII code 0Ah, set remaining char = 20h	0 A	0000 1010		

Product Specification

APPENDIX A. Enhanced Extended Display Identification Data (EEDID™) 3/3

Byte# (decimal)	Byte# (HEX)	Field Name and Comments	Value (HEX)		Value (binary)		
108	6C	Flag	0	0	0000	0000	Detailed Timing Description #4
109	6D	Flag	0	0	0000	0000	
110	6E	Flag	0	0	0000	0000	
111	6F	Data Type Tag : ASCII String	F	E	1111	1110	
112	70	Flag	0	0	0000	0000	
113	71	SMBUS Value = 20nits	C	8	1100	0000	
114	72	SMBUS Value = 29nits	B	8	1011	0000	
115	73	SMBUS Value = 43 nits	A	8	1010	0000	
116	74	SMBUS Value = 64 nits	9	8	1000	1000	
117	75	SMBUS Value = 94 nits	8	8	0111	0000	
118	76	SMBUS Value = 138 nits	6	8	0110	0000	
119	77	SMBUS Value = 204 nits	4	8	0000	0111	
120	78	SMBUS Value = max nits (Typically = 00h)	0	0	0000	0000	
121	79	Number of LVDS receiver chips = 1 or 2	0	1	0000	0001	
122	7A	Panel Type – Standard = 00, UltraSharp = 01, Future codes = 02	0	1	0000	0001	
123	7B	(If<13 char, then terminate with ASCII code 0Ah, set remaining char=20h)	0	A	0000	1010	
124	7C	(If<13 char, then terminate with ASCII code 0Ah)	2	0	0010	0000	
125	7D	(If<13 char, then terminate with ASCII code 0Ah)	2	0	0010	0000	
126	7E	Extension flag = 00	0	0	0000	0000	Extension Flag
127	7F	Checksum	4	F	0000	1111	Checksum