

# SPECIFICATION FOR APPROVAL

( ◆ ) Preliminary Specification

( ) Final Specification

Title	15.6" HD TFT LCD
-------	------------------

Customer	
MODEL	

SUPPLIER	LG Display Co., Ltd.
*MODEL	LP156WHB
Suffix	TPC1

\*When you obtain standard approval,  
please use the above model name without suffix

APPROVED BY	SIGNATURE
/	_____
/	_____
/	_____

Please return 1 copy for your confirmation with your signature and comments.

APPROVED BY	SIGNATURE
J. S. Park / Manager	_____
REVIEWED BY	
S. W. Kim / Manager	_____
PREPARED BY	
K. T. Baek / Engineer	_____
C. Y. Jung / Engineer	_____

**Products Engineering Dept.  
LG Display Co., Ltd**

## Contents

<b>RECORD OF REVISIONS.....</b>	<b>3</b>
<b>1. GENERAL DESCRIPTION.....</b>	<b>4</b>
<b>2. ABSOLUTE MAXIMUM RATINGS.....</b>	<b>5</b>
<b>3. ELECTRICAL SPECIFICATIONS.....</b>	<b>6</b>
3-1. LCD ELECTRICAL CHARACTERISTICS.....	6
3-2. LED BACKLIGHT ELECTRICAL CHARACTERISTICS.....	6
3-3. INTERFACE CONNECTIONS.....	8
3-4. LVDS SIGNAL TIMING SPECIFICATION.....	9
3-5. SIGNAL TIMING SPECIFICATIONS.....	11
3-6. SIGNAL TIMING WAVEFORMS.....	11
3-7. COLOR INPUT DATA REFERENCE.....	12
3-8. POWER SEQUENCE.....	13
<b>4. OPTICAL SPECIFICATIONS.....</b>	<b>14</b>
<b>5. MECHANICAL CHARACTERISTICS.....</b>	<b>17</b>
<b>6. RELIABILITY.....</b>	<b>25</b>
<b>7. INTERNATIONAL STANDARDS.....</b>	<b>26</b>
7-1. SAFETY.....	26
7-2. ENVIRONMENT.....	26
<b>8. PACKING.....</b>	<b>27</b>
8-1. DESIGNATION OF LOT MARK.....	27
8-2. PACKING FORM.....	27
<b>9. PRECAUTIONS.....</b>	<b>28</b>
 APPENDIX A. LGD PROPOSAL FOR SYSTEM COVER DESIGN.....	 20
APPENDIX B. LGD PROPOSAL FOR eDP INTERFACE DESIGN GUIDE.....	20
APPENDIX C. ENHANCED EXTENDED DISPLAY IDENTIFICATION DATA.....	30

## Product Specification

**Record of Revisions**

Revision No	Revision Date	Page	Description	EDID version
0.0	Mar. 10. 2014	All	First Draft (Preliminary Specification)	0.0

## 1. General Description

The LP156WHB is a Color Active Matrix Liquid Crystal Display with an integral LED backlight system. The matrix employs a-Si Thin Film Transistor as the active element. It is a transmissive type display operating in the normally white mode. This TFT-LCD has 15.6 inches diagonally measured active display area with HD resolution (1366 horizontal by 768 vertical pixel array). Each pixel is divided into Red, Green and Blue sub-pixels or dots which are arranged in vertical stripes. Gray scale or the brightness of the sub-pixel color is determined with a 6-bit gray scale signal for each dot, thus, presenting a palette of more than 262,144 colors. The LP156WHB has been designed to apply the interface method that enables low power, high speed, low EMI. The LP156WHB is intended to support applications where thin thickness, low power are critical factors and graphic displays are important. In combination with the vertical arrangement of the sub-pixels, the LP156WHB characteristics provide an excellent flat display for office automation products such as Notebook PC.

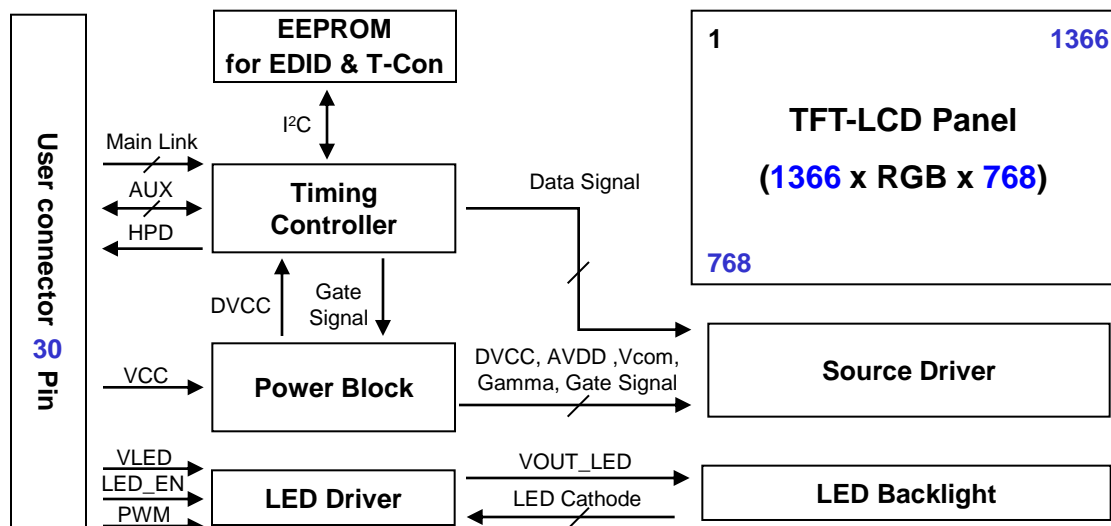

## General Features

Active Screen Size	15.6 inches diagonal
Outline Dimension	359.5(H, Typ.) × 217.2(V, Typ.) × 3.80(D, Max.) [mm] (with PCBA)
Pixel Pitch	0.252 mm X 0.252 mm
Pixel Format	1366 horiz. by 768 vert. Pixels RGB strip arrangement
Color Depth	6-bit, 262,144 colors
Luminance, White	220 cd/m <sup>2</sup> (Typ.)
Power Consumption	Total 3.04W (Typ.) Logic : 0.7W (Typ. @ Mosaic), B/L : 2.34W (Typ.)
Weight	400g (Max.)
Display Operating Mode	Normally white
Surface Treatment	Glare treatment (3H) of the front Polarizer
RoHS Compliance	Yes
BFR / PVC / As Free	Yes for all

## 2. Absolute Maximum Ratings

The following are maximum values which, if exceeded, may cause faulty operation or damage to the unit.

**Table 1. ABSOLUTE MAXIMUM RATINGS**

Parameter	Symbol	Values		Units	Notes
		Min	Max		
Power Input Voltage	VCC	-0.3	4.0	V <sub>DC</sub>	at 25 ± 2°C
Operating Temperature	TOP	0	50	°C	1
Storage Temperature	HST	-20	60	°C	1
Operating Ambient Humidity	HOP	10	90	%RH	1
Storage Humidity	HST	10	90	%RH	1

Note : 1. Temperature and relative humidity range are shown in the figure below.  
Wet bulb temperature should be 39°C Max, and no condensation of water.  
Note : 2. Storage Condition is guaranteed under packing condition.

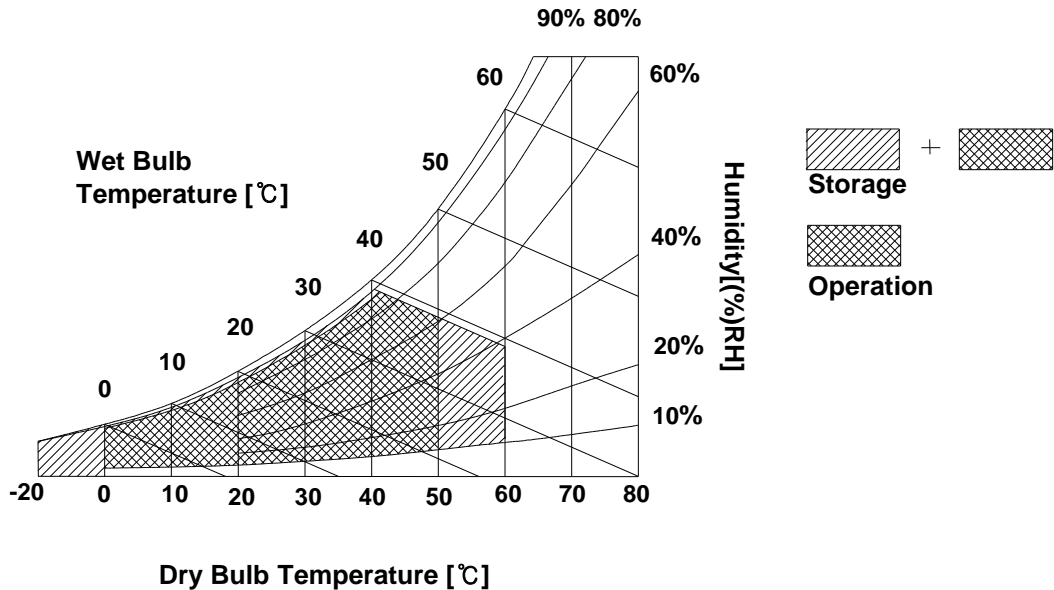

### 3. Electrical Specifications

#### 3-1. LCD Electrical Characteristics

**Table 2. LCD ELECTRICAL CHARACTERISTICS**

Parameter	Symbol	Values			Unit	Notes	
		Min	Typ	Max			
Power Supply Input Voltage	$V_{CC}$	3.0	3.3	3.6	V	1	
Permissive Power Supply Input Ripple	$V_{CCrp}$	-	-	100	mV <sub>p-p</sub>		
Power Supply Input Current	Mosaic	$I_{CC}$	-	220	255	mA	2
Power Consumption (Mosaic)	$P_{CC}$	-	0.7	0.8	W		
Power Supply Inrush Current	$I_{CC\_P}$	-	-	1.5	A	3	
Differential Impedance	$Z_m$	90	100	110	$\Omega$		

Note)

- The measuring position is the connector of LCM and the test conditions are under 25°C,  $f_v = 60\text{Hz}$
- The specified  $I_{CC}$  current and power consumption are under the  $V_{CC} = 3.3\text{V}$ , 25°C,  $f_v = 60\text{Hz}$  condition and **Mosaic** pattern / Sub. Pixel pattern.

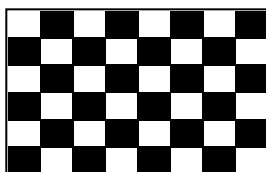

< Mosaic >

- The  $V_{CC}$  rising time is same as the minimum of T1 at Power on sequence.

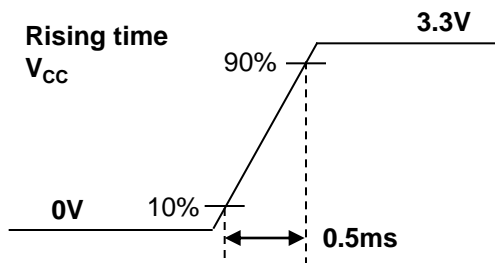

### 3-2. LED Backlight Electrical Characteristics

**Table 3. LED B/L ELECTRICAL CHARACTERISTICS**

Parameter		Symbol	Values			Unit	Notes
			Min	Typ	Max		
LED Power Input Voltage		$V_{LED}$	6.0	12.0	21.0	V	1
LED Power Input Current		$I_{LED}$	-	195	215	mA	2
LED Power Consumption		$P_{LED}$	-	2.35	2.58	W	
LED Power Inrush Current		$I_{LED\_P}$	-	-	1.5	A	3
PWM Duty Ratio			5	-	100	%	4
PWM Jitter			0	-	0.2	%	5
PWM Frequency		$F_{PWM}$	200	-	1000	Hz	6
PWM	High Level Voltage	$V_{PWM\_H}$	2.5	-	3.6	V	
	Low Level Voltage	$V_{PWM\_L}$	0	-	0.3	V	
LED_EN	High Voltage	$V_{LED\_EN\_H}$	2.5	-	3.6	V	
	Low Voltage	$V_{LED\_EN\_L}$	0	-	0.3	V	
Life Time			12,000	-	-	Hrs	7

Note)

1. The measuring position is the connector of LCM and the test conditions are under 25°C.
2. The current and power consumption with LED Driver are under the  $V_{LED} = 12.0V$ , 25°C, PWM Duty 100% and White pattern with the normal frame frequency operated(60Hz).
3. The  $V_{LED}$  rising time is same as the minimum of T13 at Power on sequence.

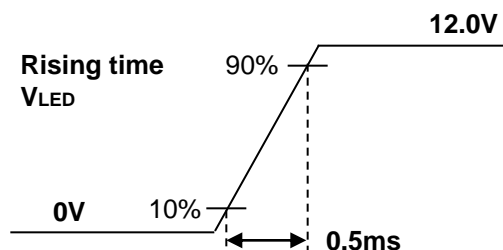

4. The operation of LED Driver below minimum dimming ratio may cause flickering or reliability issue.
5. If Jitter of PWM is bigger than maximum, it may induce flickering.
6. This Spec. is not effective at 100% dimming ratio as an exception because it has DC level equivalent to 0Hz. In spite of acceptable range as defined, the PWM Frequency should be fixed and stable for more consistent brightness control at any specific level desired.
7. The life time is determined as the time at which brightness of LCD is 50% compare to that of minimum value specified in table 7. under general user condition.

## Product Specification

**3-3. Interface Connections**
**Table 4. MODULE CONNECTOR PIN CONFIGURATION (CN1)**

Pin	Symbol	Description	Notes
1	NC	No Connection	[Connector] HRS, KN38-030S-0.5H or equivalent  [Connector pin arrangement]   [LGD P-Vcom using information] 1. Pin for P-Vcom : #24, #25 2. P-Vcom Address : 0101000x
2	GND	High Speed Ground	
3	NC	No Connection	
4	NC	No Connection	
5	GND	High Speed Ground	
6	Lane0_N	Complement Signal Link Lane 0	
7	Lane0_P	True Signal Link Lane 0	
8	GND	High Speed Ground	
9	AUX_CH_P	True Signal Auxiliary Channel	
10	AUX_CH_N	Complement Signal Auxiliary Channel	
11	GND	High Speed Ground	
12	VCC	LCD logic and driver power	
13	VCC	LCD logic and driver power	
14	NC	No Connection	
15	GND	LCD logic and driver ground	
16	GND	LCD logic and driver ground	
17	HPD	HPD signal pin	
18	BL_GND	LED Backlight ground	
19	BL_GND	LED Backlight ground	
20	BL_GND	LED Backlight ground	
21	BL_GND	LED Backlight ground	
22	BL ENABLE	LED Backlight control on/off control	
23	BL PWM	System PWM signal input for dimming	
24	NC Reserved	Reserved for LCD manufacture's use	
25	NC Reserved	Reserved for LCD manufacture's use	
26	VLED	LED Backlight power (12V Typical)	
27	VLED	LED Backlight power (12V Typical)	
28	VLED	LED Backlight power (12V Typical)	
29	VLED	LED Backlight power (12V Typical)	
30	NC Reserved	Reserved for LCD manufacture's use	



### 3-3. eDP Signal Timing Specifications

#### 3-3-1. Definition of Differential Voltage

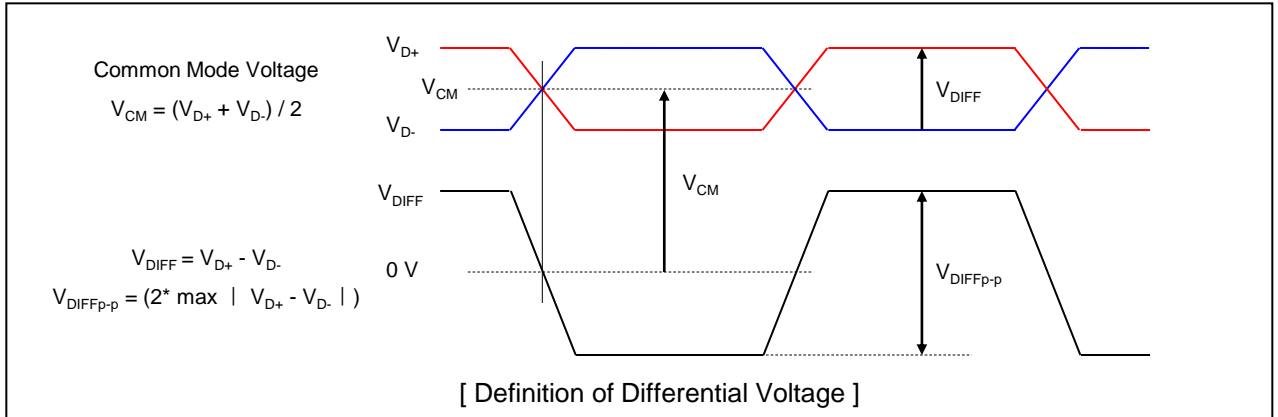

#### 3-3-2. Main Link EYE Diagram

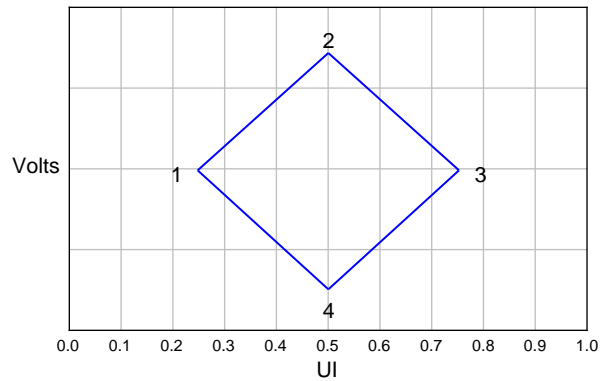
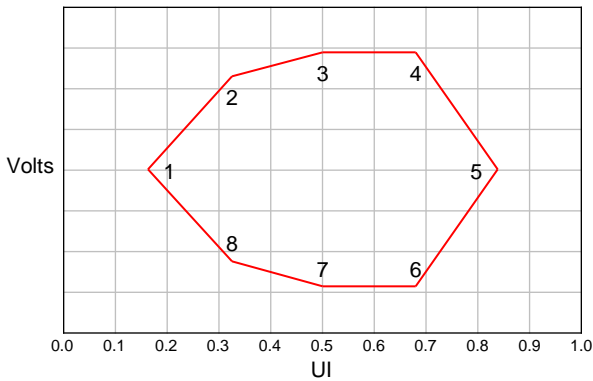

Point	Reduced Bit Rate		High Bit Rate	
	Time(UI)	Voltage(V)	Time(UI)	Voltage(V)
1	0.127	0.000	0.210	0.000
2	0.291	0.160	0.355	0.140
3	0.500	0.200	0.500	0.175
4	0.709	0.200	0.645	0.175
5	0.873	0.000	0.790	0.000
6	0.709	-0.200	0.645	-0.175
7	0.500	-0.200	0.500	-0.175
8	0.291	-0.160	0.355	-0.140

[ EYE Mask Vertices at Source Connector Pins ]

Point	Reduced Bit Rate		High Bit Rate	
	Time(UI)	Voltage(V)	Time(UI)	Voltage(V)
1	0.375	0.000	0.246	0.000
2	0.500	0.023	0.500	0.075
3	0.625	0.000	0.755	0.000
4	0.500	-0.023	0.500	-0.075

[ EYE Mask Vertices at Sink Connector Pins ]

Point	Reduced Bit Rate		High Bit Rate	
	Time(UI)	Voltage(V)	Time(UI)	Voltage(V)
1	0.270	0.000	0.246	0.000
2	0.500	0.068	0.500	0.075
3	0.731	0.000	0.755	0.000
4	0.500	-0.068	0.500	-0.075

[ EYE Mask Vertices at embedded DP Sink Connector Pins ]

### 3-3-3. eDP Main Link Signal

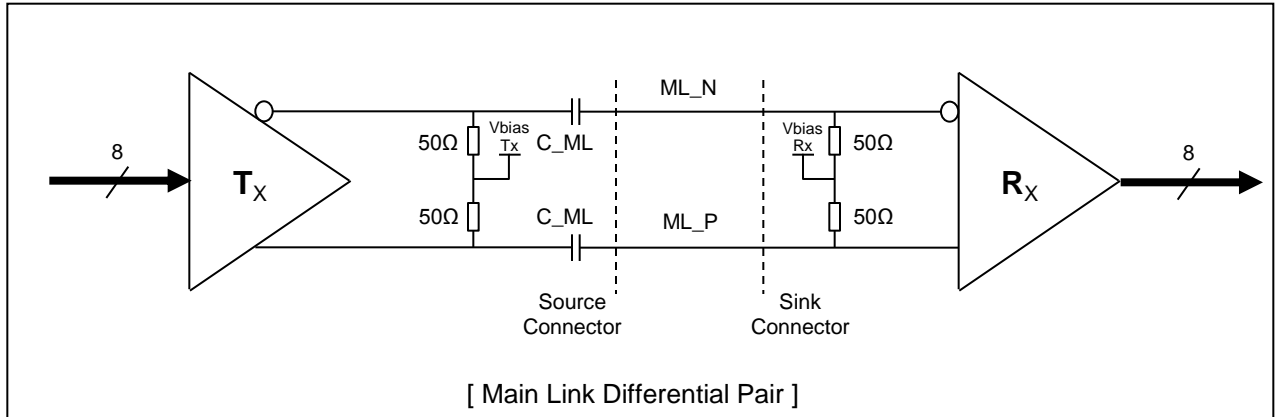

Parameter	Symbol	Min	Typ	Max	Unit	Notes
Unit Interval for high bit rate (2.7Gbps / lane)	UI_HBR	-	370	-	ps	
Unit Interval for reduced bit rate (1.62Gbps / lane)	UI_RBR	-	617	-	ps	
Link Clock Down Spreading	Amplitude	0	-	0.5	%	
	Frequency	30		33	kHz	
Differential peak-to-peak voltage at Source side connector	$V_{TX-DIFFP-P}$	350	-	-	mV	For HBR(2.7Gbps)
		400	-	-		For RBR(1.62Gbps)
EYE width at Source side connector	$T_{TX-EYE-CONN}$	0.58	-	-	UI	For HBR(2.7Gbps)
		0.75	-	-	UI	For RBR(1.62Gbps)
Differential peak-to-peak voltage at Sink side connector	$V_{RX-DIFFP-P}$	150	-	-	mV	For HBR(2.7Gbps)
		136	-	-		For RBR(1.62Gbps)
EYE width at Sink side connector	$T_{RX-EYE-CONN}$	0.51	-	-	UI	For HBR(2.7Gbps)
		0.46	-	-	UI	For RBR(1.62Gbps)
Rx DC common mode voltage	$V_{RX CM}$	0	-	1.0	V	
AC Coupling Capacitor	$C_{SOURCE-ML}$	75		200	nF	Source side

Note)

1. Termination resistor is typically integrated into the transmitter and receiver implementations.
2. AC Coupling Capacitor is not placed at the sink side.
3. In cabled embedded system, it is recommended the system designer ensure that EYE width and voltage are met at the sink side connector pins.

## Product Specification

## 3-3-4. eDP AUX Channel Signal

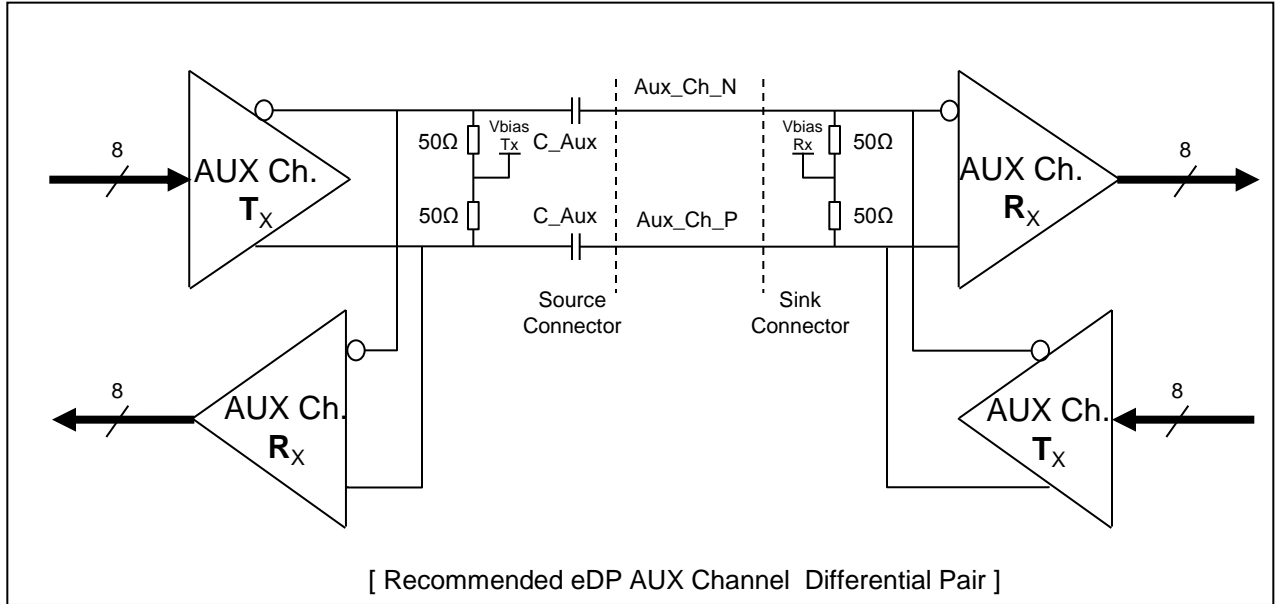

Parameter	Symbol	Min	Typ	Max	Unit	Notes
AUX Unit Interval	UI	0.4	-	0.6	us	
AUX Jitter at Tx IC Package Pins	$T_{jitter}$	-	-	0.04	UI	Equal to 24ns
AUX Jitter at Rx IC Package Pins		-	-	0.05	UI	Equal to 30ns
AUX Peak-to-peak voltage at Connector Pins of Receiving	$V_{AUX-DIFFp-p}$	0.39	-	1.38	V	
AUX Peak-to-peak voltage at Connector Pins of Transmitting		0.36	-	1.36	V	
AUX EYE width at Connector Pins of Tx and Rx		0.98	-	-	UI	
AUX DC common mode voltage	$V_{AUX-CM}$	0	-	1.0	V	
AUX AC Coupling Capacitor	$C_{SOURCE-AUX}$	75		200	nF	Source side

Note)

1. Termination resistor is typically integrated into the transmitter and receiver implementations.
2. AC Coupling Capacitor is not placed at the sink side.
3.  $V_{AUX-DIFFp-p} = 2 * | V_{AUXP} - V_{AUXN} |$

Product Specification

**3-3-5. eDP HPD Signal**

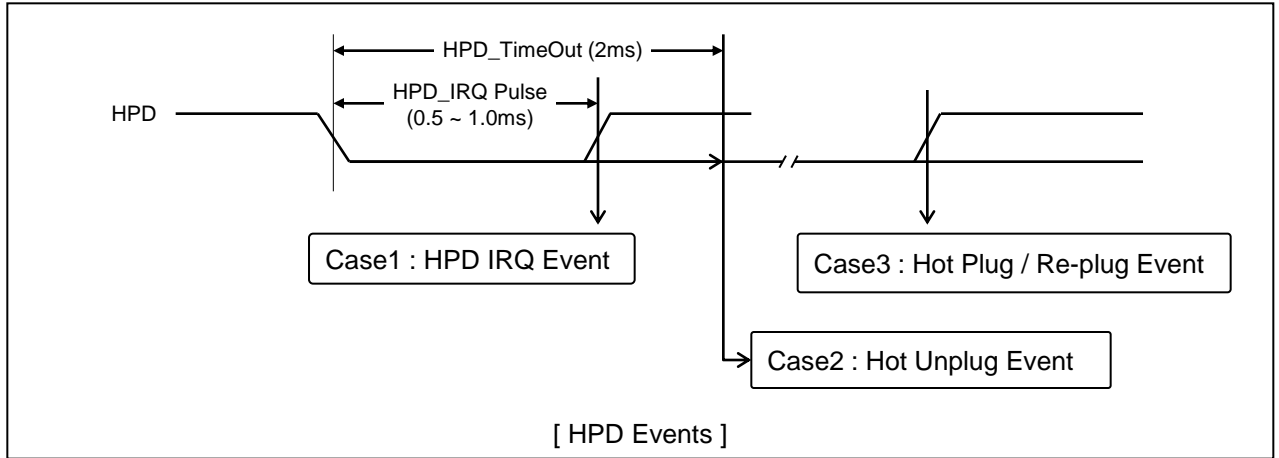

Parameter	Symbol	Min	Typ	Max	Unit	Notes
HPD Voltage	HPD	2.25	-	3.6	V	Sink side Driving
Hot Plug Detection Threshold		2.0	-	-	V	Source side Detecting
Hot Unplug Detection Threshold		-	-	0.8	V	
HPD_IRQ Pulse Width	HPD_IRQ	0.5	-	1.0	ms	
HPD_TimeOut		2.0	-	-	ms	HPD Unplug Event

Note)

1. HPD IRQ : Sink device wants to notify the Source device that Sink's status has changed so it toggles HPD line, forcing the Source device to read its Link / Sink Receiver DPCD field via the AUX-CH
2. HPD Unplug : The Sink device is no longer attached to the Source device and the Source device may then disable its Main Link as a power saving mode
3. Plug / Re-plug : The Sink device is now attached to the Source device, forcing the Source device to read its Receiver capabilities and Link / Sink status Receiver DPCD fields via the AUX-CH

### 3-4. Signal Timing Specifications

This is the signal timing required at the input of the User connector. All of the interface signal timing should be satisfied with the following specifications and specifications of eDP Tx/Rx for its proper operation.

**Table 4. TIMING TABLE**

ITEM	Symbol	Min	Typ	Max	Unit	Note
DCLK	Frequency	$f_{CLK}$	-	76.32	-	MHz
Hsync	Period	$t_{HP}$	1594	1610	1626	$t_{CLK}$
	Width	$t_{WH}$	24	32	40	
	Width-Active	$t_{WHA}$	1366			
Vsync	Period	$t_{VP}$	787	790	793	$t_{HP}$
	Width	$t_{WV}$	4	5	6	
	Width-Active	$t_{WVA}$	768			
Data Enable	Horizontal back porch	$t_{HBP}$	160	164	168	$t_{CLK}$
	Horizontal front porch	$t_{HFP}$	44	48	52	
	Vertical back porch	$t_{VBP}$	13	14	15	$t_{HP}$
	Vertical front porch	$t_{VFP}$	2	3	4	

**Notice.** all reliabilities are specified for timing specification based on refresh rate of 60Hz. However, LP156WHB has a good actual performance even at lower refresh rate (e.g. 40Hz or 50Hz) for power saving Mode, whereas LP156WHB is secured only for function under lower refresh rate. 60Hz at Normal mode, 50Hz, 40Hz at Power save mode. Don't care Flicker level (Power save mode).

### 3-5. Signal Timing Waveforms

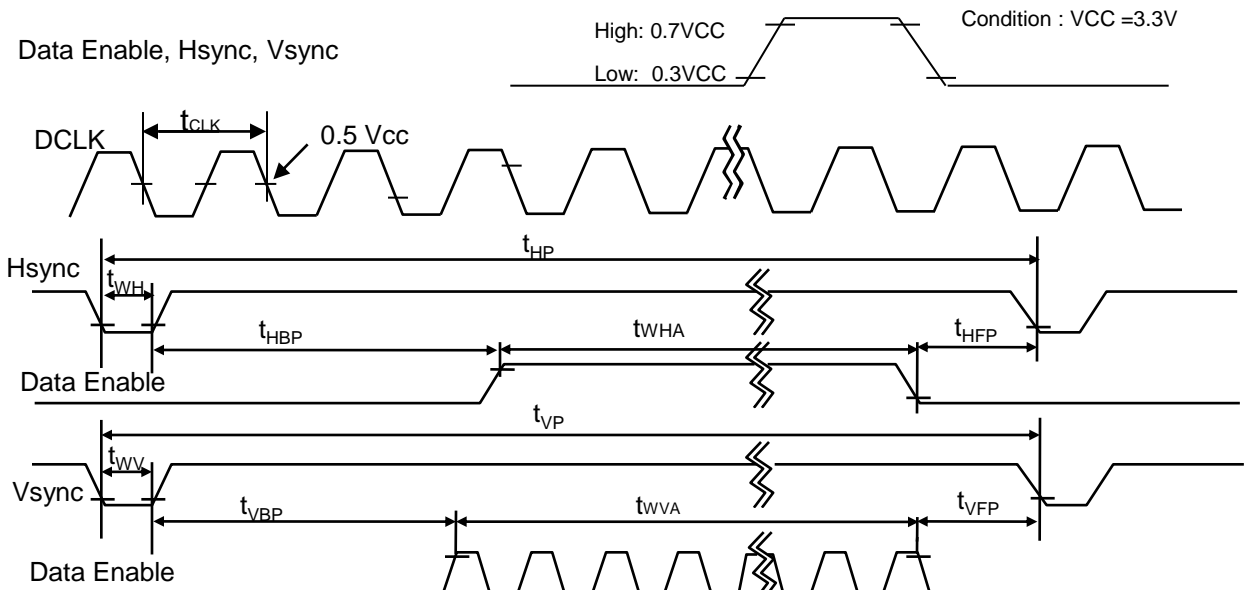

## Product Specification

### 3-6. Color Input Data Reference

The brightness of each primary color (red, green and blue) is based on the 6-bit gray scale data input for the color ; the higher the binary input, the brighter the color. The table below provides a reference for color versus data input.

**Table 5. COLOR DATA REFERENCE**

Color		Input Color Data																			
		RED						GREEN						BLUE							
		MSB						LSB		MSB						LSB		MSB			
		R 5	R 4	R 3	R 2	R 1	R 0	G 5	G 4	G 3	G 2	G 1	G 0	B 5	B 4	B 3	B 2	B 1	B 0		
Basic Color	Black	0	0	0	0	0	0	0	0	0	0	0	0	0	0	0	0	0	0		
	Red	1	1	1	1	1	1	0	0	0	0	0	0	0	0	0	0	0	0		
	Green	0	0	0	0	0	0	1	1	1	1	1	1	0	0	0	0	0	0		
	Blue	0	0	0	0	0	0	0	0	0	0	0	0	1	1	1	1	1	1		
	Cyan	0	0	0	0	0	0	1	1	1	1	1	1	1	1	1	1	1	1		
	Magenta	1	1	1	1	1	1	0	0	0	0	0	0	1	1	1	1	1	1		
	Yellow	1	1	1	1	1	1	1	1	1	1	1	1	0	0	0	0	0	0		
White	1	1	1	1	1	1	1	1	1	1	1	1	1	1	1	1	1	1			
RED	RED (00)	0	0	0	0	0	0	0	0	0	0	0	0	0	0	0	0	0	0		
	RED (01)	0	0	0	0	0	1	0	0	0	0	0	0	0	0	0	0	0	0		
	...	...						...						...							
	RED (62)	1	1	1	1	1	0	0	0	0	0	0	0	0	0	0	0	0	0		
	RED (63)	1	1	1	1	1	1	0	0	0	0	0	0	0	0	0	0	0	0		
GREEN	GREEN (00)	0	0	0	0	0	0	0	0	0	0	0	0	0	0	0	0	0	0		
	GREEN (01)	0	0	0	0	0	0	0	0	0	0	0	1	0	0	0	0	0	0		
	...	...						...						...							
	GREEN (62)	0	0	0	0	0	0	1	1	1	1	1	0	0	0	0	0	0	0		
	GREEN (63)	0	0	0	0	0	0	1	1	1	1	1	1	0	0	0	0	0	0		
BLUE	BLUE (00)	0	0	0	0	0	0	0	0	0	0	0	0	0	0	0	0	0	0		
	BLUE (01)	0	0	0	0	0	0	0	0	0	0	0	0	0	0	0	0	0	1		
	...	...						...						...							
	BLUE (62)	0	0	0	0	0	0	0	0	0	0	0	0	1	1	1	1	1	0		
	BLUE (63)	0	0	0	0	0	0	0	0	0	0	0	0	1	1	1	1	1	1		

Product Specification

3-7. Power Sequence

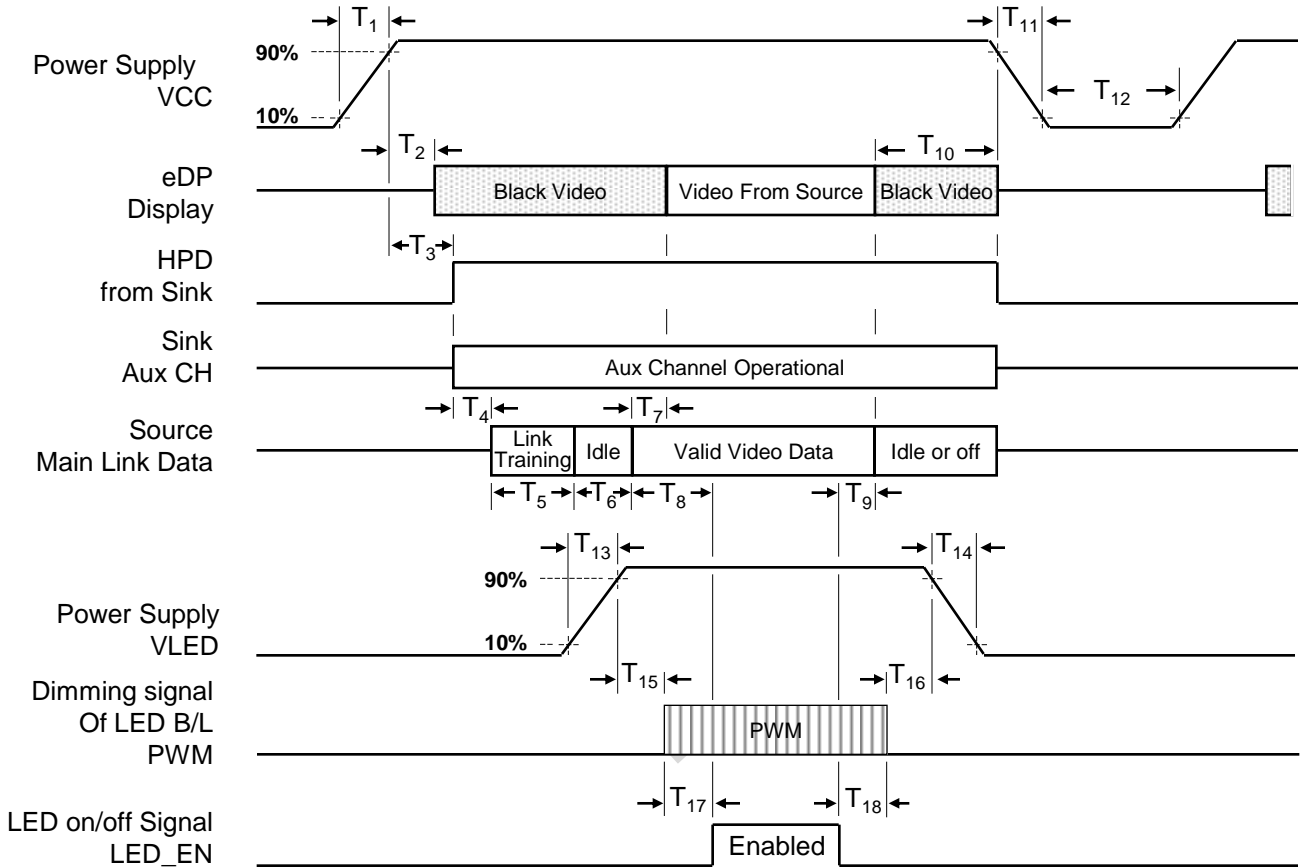

Table 6. POWER SEQUENCE TABLE

Symbol	Required By	Limits		Units	Notes	Symbol	Required By	Limits		Units	Notes
		Min	Max					Min	Max		
T <sub>1</sub>	Source	0.5	10	ms	-	T <sub>10</sub>	Source	0	500	ms	-
T <sub>2</sub>	Sink	0	200	ms	-	T <sub>11</sub>	Source	-	10	ms	-
T <sub>3</sub>	Sink	0	200	ms	-	T <sub>12</sub>	Source	200	-	ms	VESA recommend Min 500ms
T <sub>4</sub>	Source	-	-	ms	-	T <sub>13</sub>	Source	0.5	10	ms	-
T <sub>5</sub>	Source	-	-	ms	-	T <sub>14</sub>	Source	0.5	10	ms	-
T <sub>6</sub>	Source	-	-	ms	-	T <sub>15</sub>	Source	0	-	ms	-
T <sub>7</sub>	Sink	0	50	ms	-	T <sub>16</sub>	Source	0	-	ms	-
T <sub>8</sub>	Source	-	-	ms	LGD recommend Min 200ms	T <sub>17</sub>	Source	0	-	ms	-
T <sub>9</sub>	Source	-	-	ms	-	T <sub>18</sub>	Source	0	-	ms	-

- Note) 1. Do not insert the mating cable when system turn on.  
 2. Valid Data have to meet "3-3. eDP Signal Timing Specifications"  
 3. Video Signal, LED\_EN and PWM need to be on pull-down condition on invalid status.  
 4. LGD recommend the rising sequence of VLED after the Vcc and valid status of Video Signal turn on.

## 4. Optical Specification

Optical characteristics are determined after the unit has been 'ON' and stable for approximately 20 minutes in a dark environment at 25°C. The values specified are at an approximate distance 50cm from the LCD surface at a viewing angle of  $\Phi$  and  $\Theta$  equal to 0°.

FIG. 1 presents additional information concerning the measurement equipment and method.

**FIG. 1 Optical Characteristic Measurement Equipment and Method**

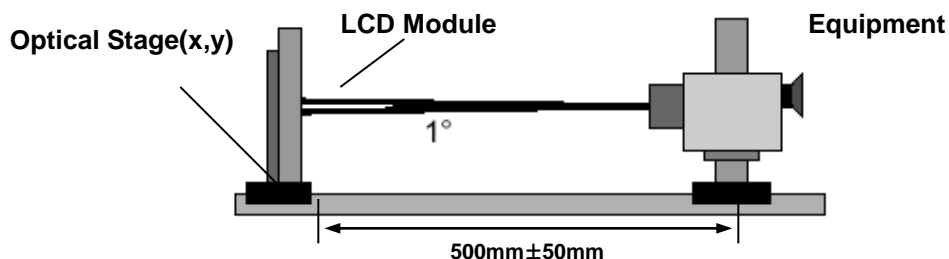

**Table 7. OPTICAL CHARACTERISTICS**

Ta=25°C, VCC=3.3V, fv=60Hz

Parameter		Symbol	Values			Units	Notes
			Min	Typ	Max		
Contrast Ratio		CR	400	500	-		1
Surface Luminance, white		L <sub>WH</sub>	187	220	-	cd/m <sup>2</sup>	2
Luminance Variation		$\delta_{\text{WHITE}(5P)}$	-	1.2	1.4	-	3
		$\delta_{\text{WHITE}(13P)}$	-	1.4	1.6		
Response Time		Tr + Tf	-	16	25	ms	4
Color Coordinates	RED	R <sub>x</sub>	Typical - 0.03	0.578	Typical + 0.03		
		R <sub>y</sub>		0.344			
	GREEN	G <sub>x</sub>		0.337			
		G <sub>y</sub>		0.571			
	BLUE	B <sub>x</sub>		0.159			
		B <sub>y</sub>		0.12			
	WHITE	W <sub>x</sub>		0.313			
W <sub>y</sub>		0.329					
Viewing Angle	x axis, right( $\Phi=0^\circ$ )	$\Theta_r$	40	45	-	Degree	5
	x axis, left ( $\Phi=180^\circ$ )	$\Theta_l$	40	45	-		
	y axis, up ( $\Phi=90^\circ$ )	$\Theta_u$	10	15	-		
	y axis, down ( $\Phi=270^\circ$ )	$\Theta_d$	30	35	-		
Gray Scale							6



## Product Specification

- Note)
1. It should be measured in the center of screen(1 Point). Contrast Ratio(CR) is defined mathematically as

$$\text{Contrast Ratio(1 Point)} = \frac{\text{Surface Luminance with all white pixels}}{\text{Surface Luminance with all black pixels}}$$

2. Surface luminance is the average of 5 point across the LCD surface 50cm from the surface with all pixels displaying white. For more information see FIG 2.

$$L_{WH} = \text{Average}(1,2, \dots 5 \text{ Point})$$

3. The variation in surface luminance , The panel total variation ( $\delta$  WHITE) is determined by measuring N at each test position 1 through 13 and then defined as following numerical formula.  
For more information see FIG 2.

$$\delta \text{ WHITE (5P)} = \frac{\text{Maximum (1,2, \dots 5 Point)}}{\text{Minimum (1,2, \dots 5 Point)}} \quad \delta \text{ WHITE (13P)} = \frac{\text{Maximum (1,2, \dots 13 Point)}}{\text{Minimum (1,2, \dots 13 Point)}}$$

4. Response time is the time required for the display to transition from white to black (rise time, Tr) and from black to white (falling time, Tf). For additional information see FIG 3.
5. Viewing angle is the angle at which the contrast ratio is greater than 10. The angles are determined for the horizontal or x axis and the vertical or y axis with respect to the z axis which is normal to the LCD surface. For more information see FIG 4.
6. Gray scale specification

Gray Level	Luminance [%] (Typ)
L0	0.12
L7	1.12
L15	4.76
L23	11.14
L31	20.11
L39	34.88
L47	52.15
L55	73.50
L63	100.0

Product Specification

**FIG. 2 Luminance**

<Measuring point for Average Luminance & measuring point for Luminance variation>

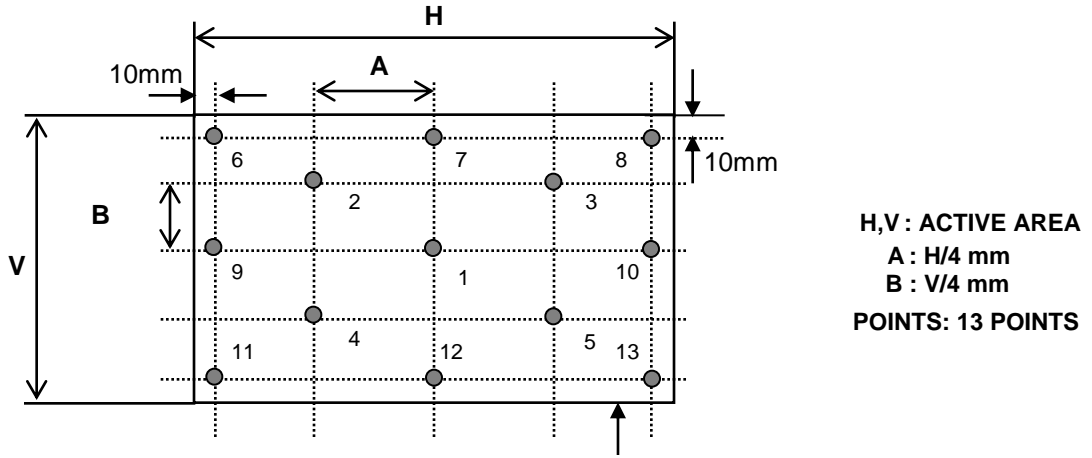

**FIG. 3 Response Time**

Active Area

The response time is defined as the following figure and shall be measured by switching the input signal for “black” and “white”.

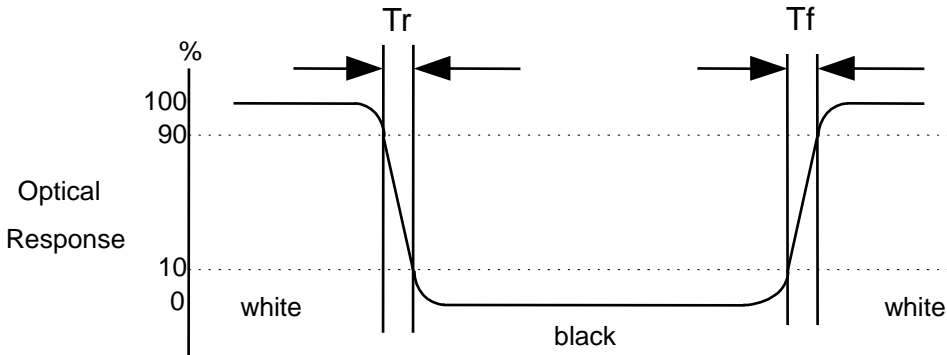

**FIG. 4 Viewing angle**

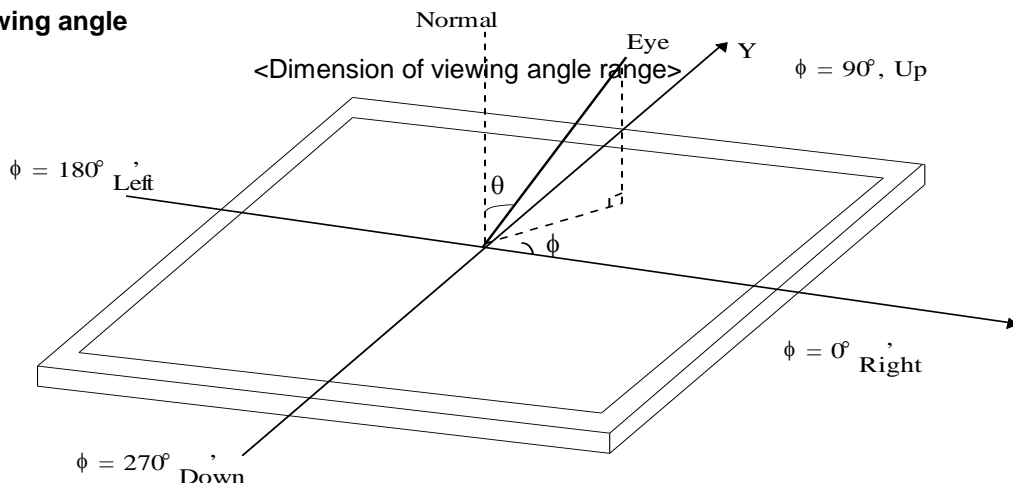

## Product Specification

## 5. Mechanical Characteristics

The contents provide general mechanical characteristics for the model LP156WHB. In addition the figures in the next page are detailed mechanical drawing of the LCD.

<b>Outline Dimension</b>	Horizontal	359.5 ± 0.5 mm
	Vertical	217.2 ± 0.5 mm (with PCBA)
	Thickness	3.8 mm (max)
<b>Bezel Area</b>	Horizontal	347.5 ± 0.5 mm
	Vertical	196.8 ± 0.5 mm
<b>Active Display Area</b>	Horizontal	344.23 mm
	Vertical	193.54 mm
<b>Weight</b>	400g (Max.)	
<b>Surface Treatment</b>	Hard Coating(3H), Glare treatment of the front polarizer	

**Product Specification**

<FRONT VIEW>

Note) Unit:[mm], General tolerance:  $\pm 0.5\text{mm}$

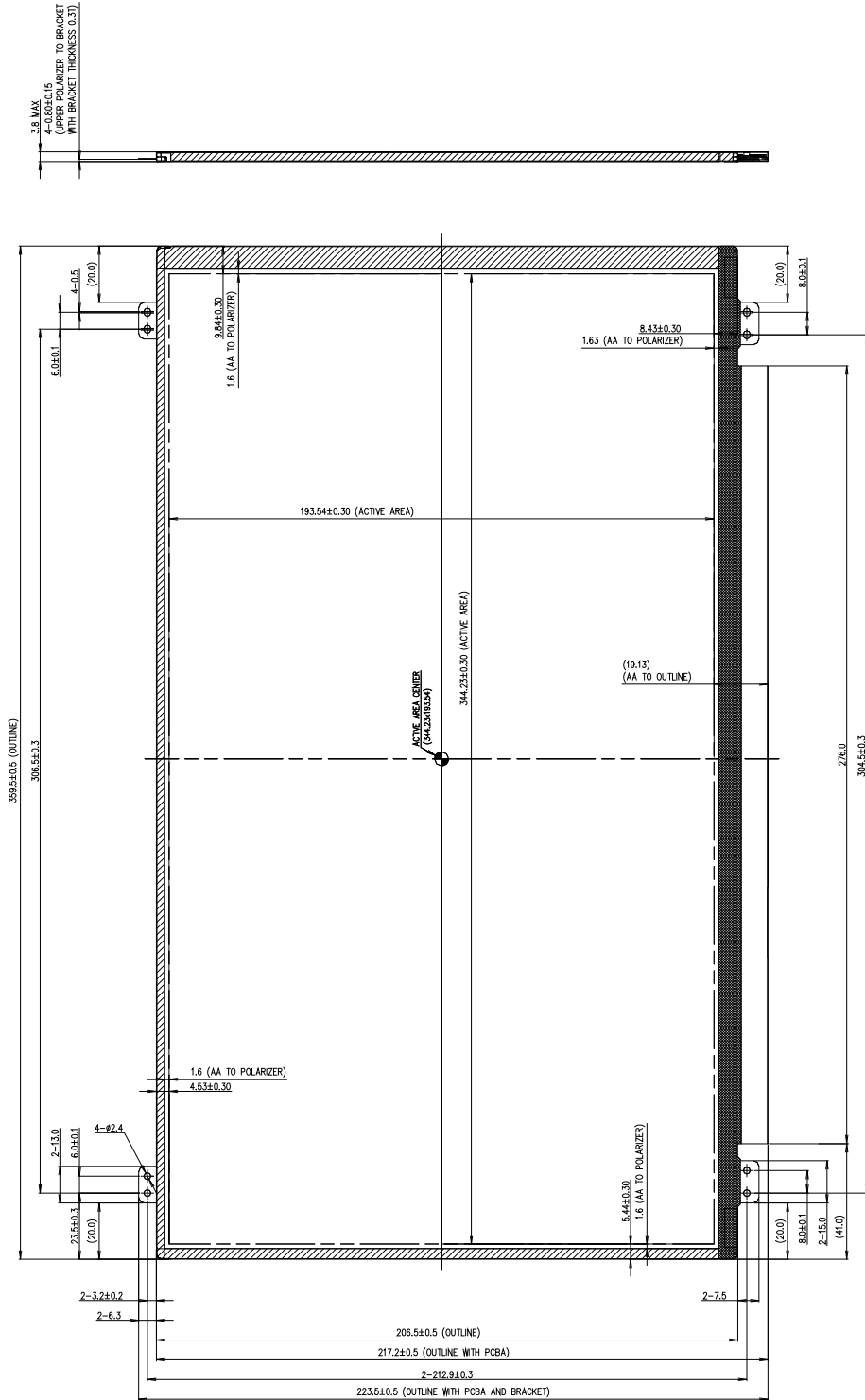

**Product Specification**

<REAR VIEW>

Note) Unit:[mm], General tolerance:  $\pm 0.5$ mm

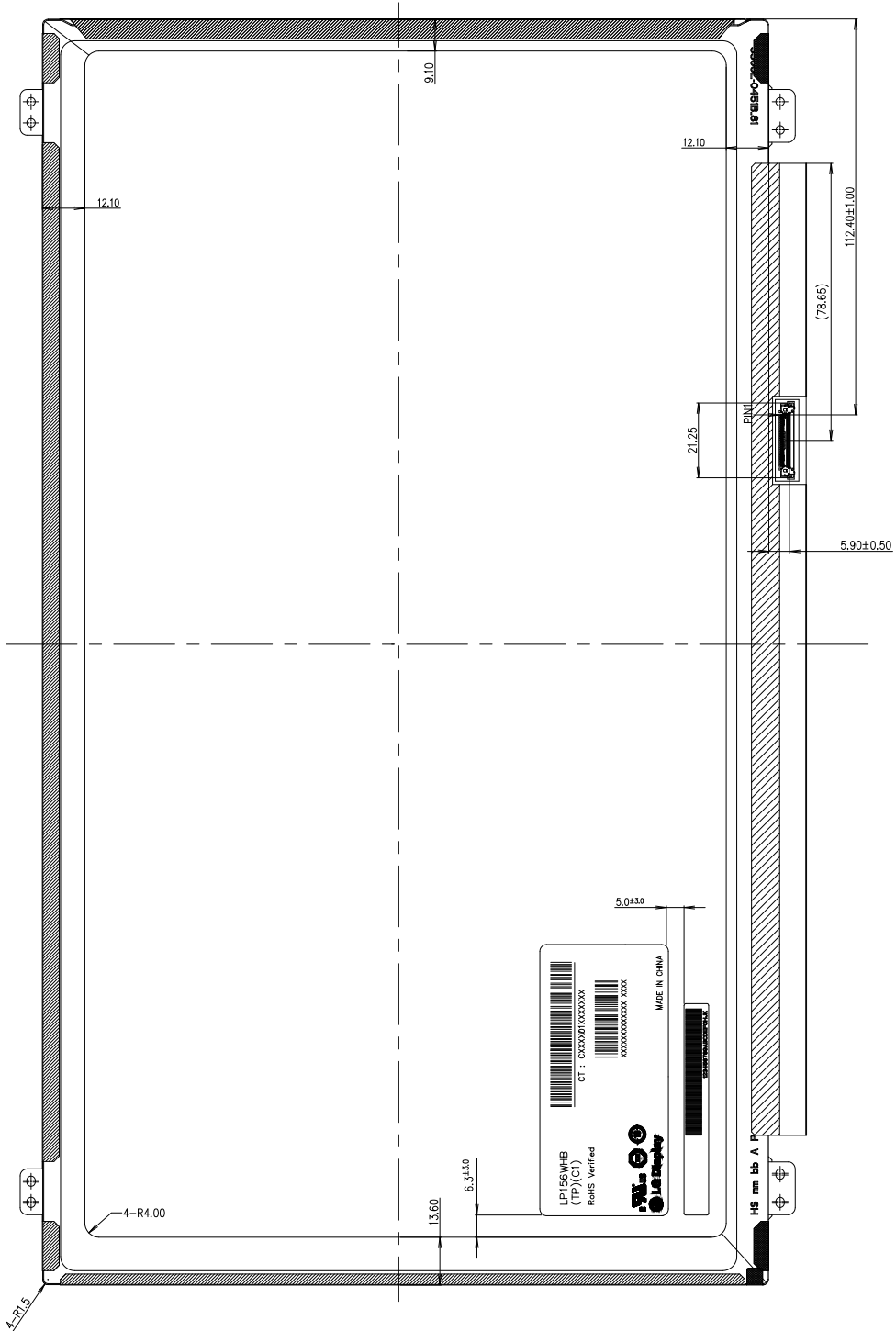

## Product Specification

## 6. Reliability

Environment test condition

No.	Test Item	Conditions
1	High temperature storage test	Ta= 60°C, 240h
2	Low temperature storage test	Ta= -20°C, 240h
3	High temperature operation test	Ta= 50°C, 50%RH, 240h
4	Low temperature operation test	Ta= 0°C, 240h
5	Vibration test (non-operating)	Random, 1.0Grms, 10 ~ 300Hz(PSD 0.0035) 3 axis, 30min/axis
6	Shock test (non-operating)	- No functional or cosmetic defects following a shock to all 6 sides delivering at least 180 G in a half sine pulse no longer than 2 ms to the display module - No functional defects following a shock delivering at least 200 g in a half sine pulse no longer than 2 ms to each of 6 sides. Each of the 6 sides will be shock tested with one each display, for a total of 6 displays
7	Altitude  operating storage / shipment	0 ~ 10,000 feet (3,048m) 24Hr 0 ~ 40,000 feet (12,192m) 24Hr

{ Result Evaluation Criteria }

There should be no change which might affect the practical display function when the display quality test is conducted under normal operating condition.

## 7. International Standards

### 7-1. Safety

- a) UL 60950-1, Underwriters Laboratories Inc.  
Information Technology Equipment - Safety - Part 1 : General Requirements.
- b) CAN/CSA-C22.2 No. 60950-1-07, Canadian Standards Association.  
Information Technology Equipment - Safety - Part 1 : General Requirements.
- c) EN 60950-1, European Committee for Electro technical Standardization (CENELEC).  
Information Technology Equipment - Safety - Part 1 : General Requirements.
- d) IEC 60950-1, The International Electro technical Commission (IEC).  
Information Technology Equipment - Safety - Part 1 : General Requirements

### 7-2. Environment

- a) RoHS, Directive 2011/65/EU of the European Parliament and of the council of 8 June 2011

## Product Specification

## 8. Packing

### 8-1. Designation of Lot Mark

a) Lot Mark

A	B	C	D	E	F	G	H	I	J	K	L	M
---	---	---	---	---	---	---	---	---	---	---	---	---

 A,B,C : SIZE(INCH)  
 E : MONTH

 D : YEAR  
 F ~ M : SERIAL NO.

Note

1. YEAR

Year	2011	2012	2013	2014	2015	2016	2017	2018	2019	2020
Mark	A	B	C	D	E	F	G	H	J	K

2. MONTH

Month	Jan	Feb	Mar	Apr	May	Jun	Jul	Aug	Sep	Oct	Nov	Dec
Mark	1	2	3	4	5	6	7	8	9	A	B	C

b) Location of Lot Mark

Serial No. is printed on the label. The label is attached to the backside of the LCD module.  
 This is subject to change without prior notice.

### 8-2. Packing Form

a) Package quantity in one box : 20pcs

b) Box Size : 478mm X 365mm X 328mm



## 9. PRECAUTIONS

Please pay attention to the followings when you use this TFT LCD module.

### 9-1. MOUNTING PRECAUTIONS

- (1) You must mount a module using holes arranged in four corners or four sides.
- (2) You should consider the mounting structure so that uneven force (ex. Twisted stress) is not applied to the module. And the case on which a module is mounted should have sufficient strength so that external force is not transmitted directly to the module.
- (3) Please attach the surface transparent protective plate to the surface in order to protect the polarizer. Transparent protective plate should have sufficient strength in order to resist external force.
- (4) You should adopt radiation structure to satisfy the temperature specification.
- (5) Acetic acid type and chlorine type materials for the cover case are not desirable because the former generates corrosive gas of attacking the polarizer at high temperature and the latter causes circuit break by electro-chemical reaction.
- (6) Do not touch, push or rub the exposed polarizers with glass, tweezers or anything harder than HB pencil lead. And please do not rub with dust clothes with chemical treatment. Do not touch the surface of polarizer for bare hand or greasy cloth.(Some cosmetics are detrimental to the polarizer.)
- (7) When the surface becomes dusty, please wipe gently with absorbent cotton or other soft materials like chamois soaks with petroleum benzene. Normal-hexane is recommended for cleaning the adhesives used to attach front / rear polarizers. Do not use acetone, toluene and alcohol because they cause chemical damage to the polarizer.
- (8) Wipe off saliva or water drops as soon as possible. Their long time contact with polarizer causes deformations and color fading.
- (9) Do not open the case because inside circuits do not have sufficient strength.
- (10) When handling the LCD module, it needs to handle with care not to give mechanical stress to the PCB and Mounting Hole area.”

### 9-2. OPERATING PRECAUTIONS

- (1) The spike noise causes the mis-operation of circuits. It should be lower than following voltage :  
 $V = \pm 200\text{mV}$ (Over and under shoot voltage)
- (2) Response time depends on the temperature.(In lower temperature, it becomes longer.)
- (3) Brightness depends on the temperature. (In lower temperature, it becomes lower.)  
And in lower temperature, response time(required time that brightness is stable after turned on) becomes longer.
- (4) Be careful for condensation at sudden temperature change. Condensation makes damage to polarizer or electrical contacted parts. And after fading condensation, smear or spot will occur.
- (5) When fixed patterns are displayed for a long time, remnant image is likely to occur.
- (6) Module has high frequency circuits. Sufficient suppression to the electromagnetic interference shall be done by system manufacturers. Grounding and shielding methods may be important to minimized the interference.

### 9-3. ELECTROSTATIC DISCHARGE CONTROL

Since a module is composed of electronic circuits, it is not strong to electrostatic discharge. Make certain that treatment persons are connected to ground through wrist band etc. And don't touch interface pin directly.

### 9-4. PRECAUTIONS FOR STRONG LIGHT EXPOSURE

Strong light exposure causes degradation of polarizer and color filter.

### 9-5. STORAGE

When storing modules as spares for a long time, the following precautions are necessary.

- (1) Store them in a dark place. Do not expose the module to sunlight or fluorescent light. Keep the temperature between 5°C and 35°C at normal humidity.
- (2) The polarizer surface should not come in contact with any other object.  
It is recommended that they be stored in the container in which they were shipped.

### 9-6. HANDLING PRECAUTIONS FOR PROTECTION FILM

- (1) When the protection film is peeled off, static electricity is generated between the film and polarizer.  
This should be peeled off slowly and carefully by people who are electrically grounded and with well ion-blown equipment or in such a condition, etc.
- (2) The protection film is attached to the polarizer with a small amount of glue. If some stress is applied to rub the protection film against the polarizer during the time you peel off the film, the glue is apt to remain on the polarizer.  
Please carefully peel off the protection film without rubbing it against the polarizer.
- (3) When the module with protection film attached is stored for a long time, sometimes there remains a very small amount of glue still on the polarizer after the protection film is peeled off.
- (4) You can remove the glue easily. When the glue remains on the polarizer surface or its vestige is recognized, please wipe them off with absorbent cotton waste or other soft material like chamois soaked with normal-hexane.

### 9-7. THE LGD QA RESPONSIBILITY WILL BE AVOIDED IN CASE OF BELOW

- (1) When the customer attaches TSM(Touch Sensor Module) on LCM without Supplier's approval.
- (2) When the customer attaches cover glass on LCM without Supplier's approval.
- (3) When the LCMs were repaired by 3rd party without Supplier's approval.
- (4) When the LCMs were treated like Disassemble and Rework by the Customer and/or Customer's representatives without supplier's approval.

**APPENDIX A. LGD Proposal for system cover design**

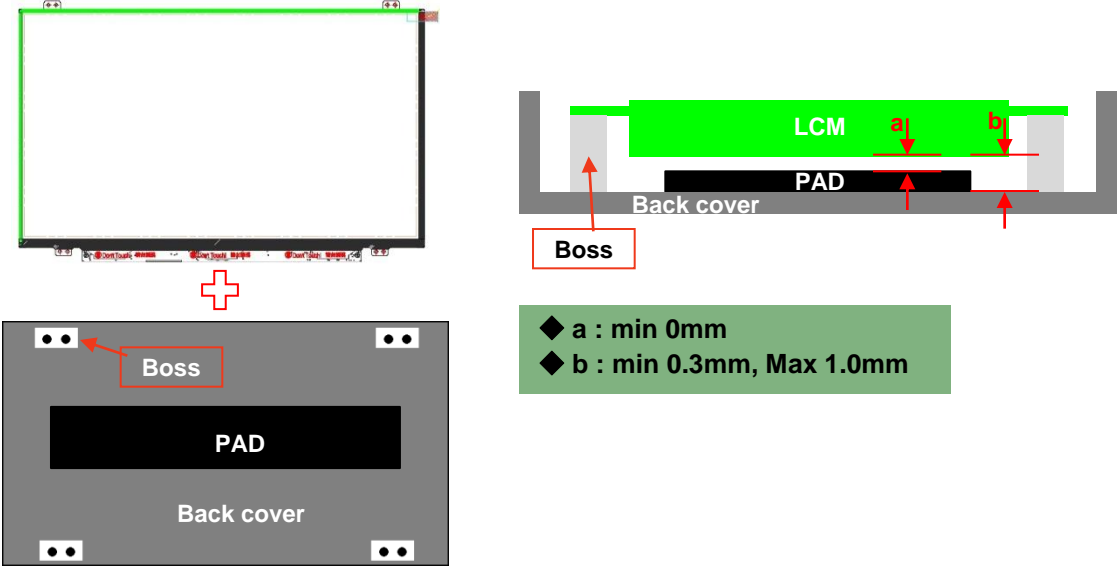
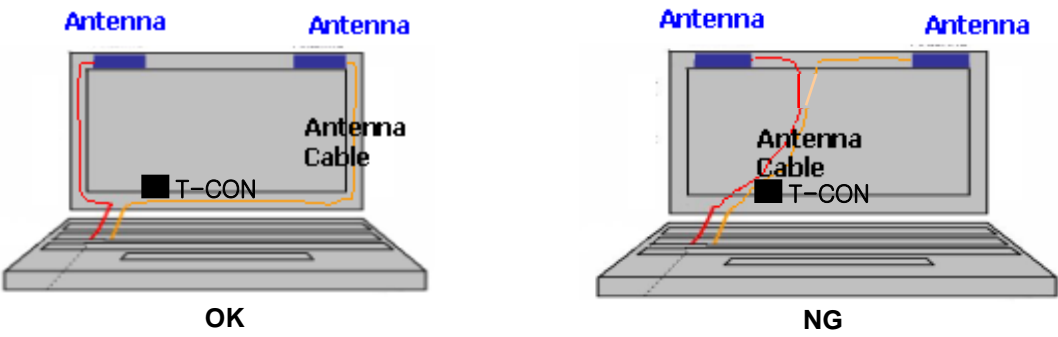
1	Gap check for securing the enough gap between LCM and System back cover.
 <p>The diagram illustrates the assembly of the LCM (Liquid Crystal Module) onto the system back cover. It shows a top-down view of the LCM and a side cross-section view. In the side view, the LCM is mounted on a PAD (padding) which is placed on the back cover. A Boss is used to secure the LCM. Dimensions 'a' and 'b' are indicated as the gap between the LCM and the back cover. A legend specifies: a : min 0mm, b : min 0.3mm, Max 1.0mm.</p>	
Define	<ol style="list-style-type: none"> <li>1. Rear side of LCM is sensitive against external stress, and previous check about interference is highly needed.</li> <li>2. In case there is something from system cover comes into the boundary above, mechanical interference may cause the FOS defects. (e.g.. Ripple, White spot..)</li> </ol>
2	Check if antenna cable is sufficiently apart from T-CON of LCD Module.
 <p>The diagram compares two scenarios for antenna cable placement relative to the T-CON (Timing Controller) of the LCD module. In the 'OK' scenario, the antenna cables are routed away from the T-CON. In the 'NG' (Not Good) scenario, the antenna cables overlap with the T-CON, which is labeled as a problem.</p>	
Define	If system antenna is overlapped with T-CON, It might be cause the noise

Product Specification

**APPENDIX A. LGD Proposal for system cover design**

3	Checking the path of the System wire
Define	<p>1. If Wire path overlapped with LCM, it is happened white spot. COF problem, etc.</p> <p>2. OK → Wire path design to system side. NG → Wire path overlapped with LCM.</p>
4	Add pad to Prevent panel crack against external load (push)
Define	<p>1. At flat type LCM, panel is easily cracked at flange area during push, assemble.</p> <p>2. Add pad, it prevent panel crack</p>

**APPENDIX A. LGD Proposal for system cover design**

5	Check the rib or Bracket on back cover
<p>The diagrams illustrate four scenarios for the back cover design:</p> <ul style="list-style-type: none"> <li><b>OK (Rib):</b> The rib height is greater than the LCM height, preventing direct compression.</li> <li><b>OK (Bracket):</b> The bracket height is greater than the LCM height, preventing direct compression.</li> <li><b>NG (Rib):</b> The rib height is less than the LCM height, leading to direct compression.</li> <li><b>CO (Bracket):</b> The bracket height is less than the LCM height, leading to direct compression.</li> </ul>	
Define	<p>1. It is necessary that the height of back cover rib or bracket is higher than LCM height. It can prevent direct compression of panel at LCM edge.</p> <p>2. "┌" shape bracket is stronger than "I" shape one.</p>
6	Check the gap between front cover and LCM (glass)
<p>The diagram shows a cross-section of the LCM on the back cover with the front cover on top. The gap between the front cover and the LCM is labeled 'a'.</p> <p><b>[OK] <math>a \geq 0.3\text{mm}</math></b>  <b>[CO] <math>0.3\text{mm} \geq a \geq 0.1\text{mm}</math></b>  <b>[NG] <math>a \leq 0.1\text{mm}</math></b></p>	
Define	Ripple can be happened by little gap between glass and front cover.

**APPENDIX A. LGD Proposal for system cover design**

<b>7</b>	<b>Check the rib or Bracket on back cover</b>
----------	---

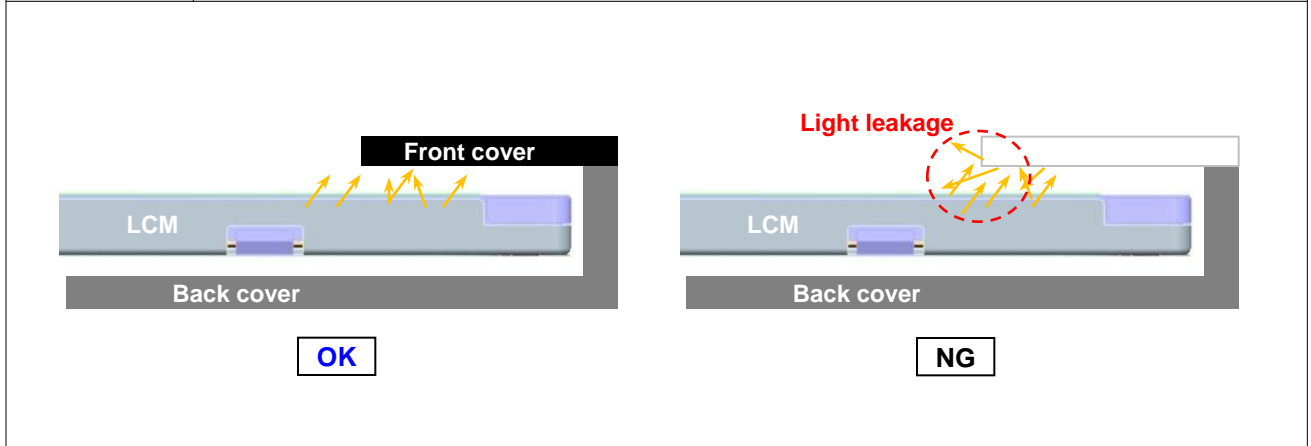

Define	1.If it is possible, shrink to apply front cover of white color.
	2. White color can caused light leakage

<b>8</b>	<b>Check the wire position(path)</b>
----------	--------------------------------------

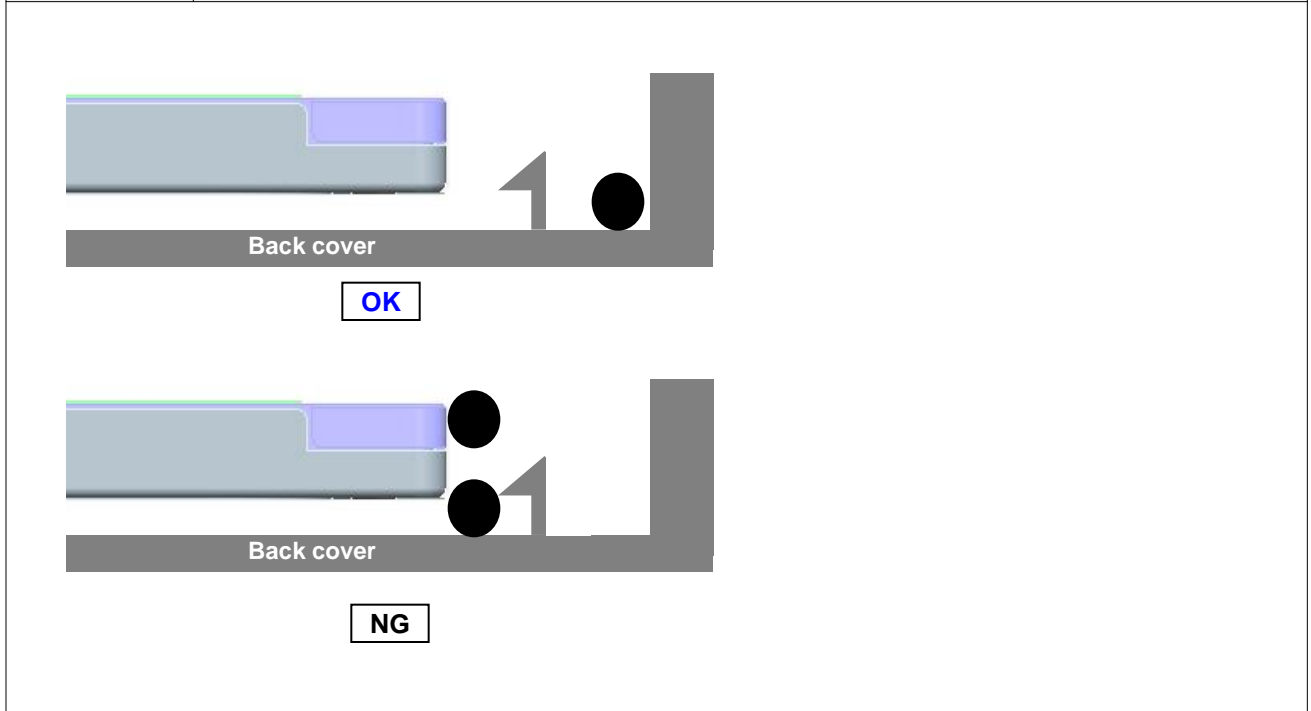

Define	1. It is necessary that wire is posited out of hook, not posited near hook,.
	2. If wire is posited near hook, it can be happened assemble error and panel crack during assemble front cover

Product Specification

**APPENDIX A. LGD Proposal for system cover design**

9	Check mouse pad (touch pad) depth and shape of edge
---	---

Mouse pad

[OK]  $a \leq 0.3\text{mm}$   
 [CO]  $0.5\text{mm} \geq a \geq 0.3\text{mm}$   
 [NG]  $a \geq 0.5\text{mm}$

OK

NG

Define	1. Mouse pad step is deep, it is caused panel crack by external load.
	2. The edge shape must be smooth.

10	Check the step of keyboard area
----	---------------------------------

OK

NG

Define	The step of keyboard at the side edge of main body, it is caused panel crack
--------	--

**APPENDIX A. LGD Proposal for system cover design**

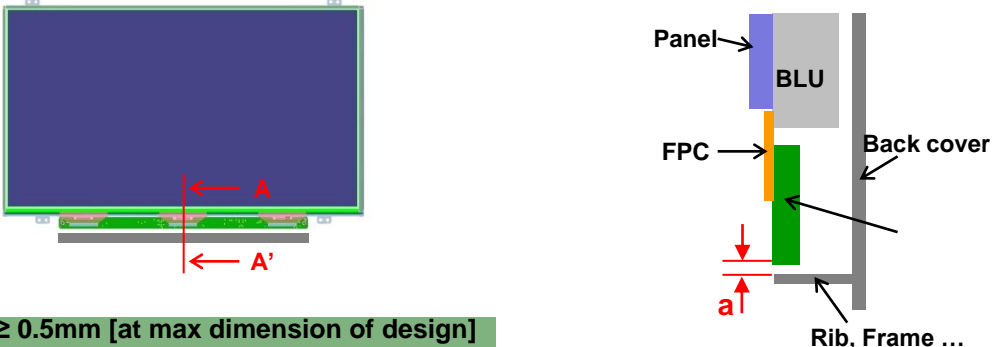
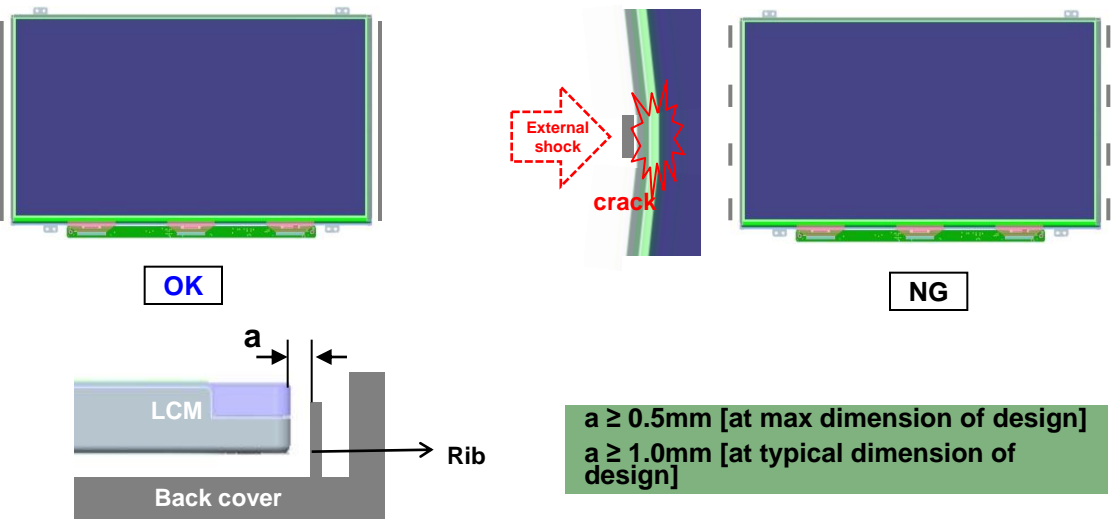
11	Check the gap [PCB ~ system]
 <p><b>a ≥ 0.5mm [at max dimension of design]</b> <b>a ≥ 1.0mm [at typical dimension of design]</b></p>	
Define	<ol style="list-style-type: none"> <li>1. Gap is too small, FPC is easily cracked by interference and repetitive bending. (circuit is opened) .</li> <li>2. Gap is must be kept more than 0.5mm(max dim.) and 1.0mm(typ dim.) .</li> </ol>
12	System rib (on A cover)
 <p><b>a ≥ 0.5mm [at max dimension of design]</b> <b>a ≥ 1.0mm [at typical dimension of design]</b></p>	
Define	<ol style="list-style-type: none"> <li>1. Gap is too small and rib is too short, panel is easily cracked by external stress.</li> <li>2. Gap is must be kept more than 0.5mm(max dim.) and 1.0mm(typ dim.) .</li> <li>3. The figure of rib is continuous or fully long.</li> </ol>



**APPENDIX B. LGD Proposal for eDP Interface Design Guide**

**1 HPD Signal recognition**

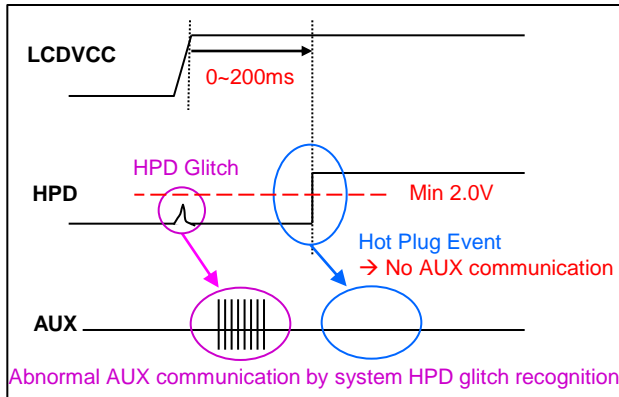

**[ Abnormal Communication By HPD Glitch ]**

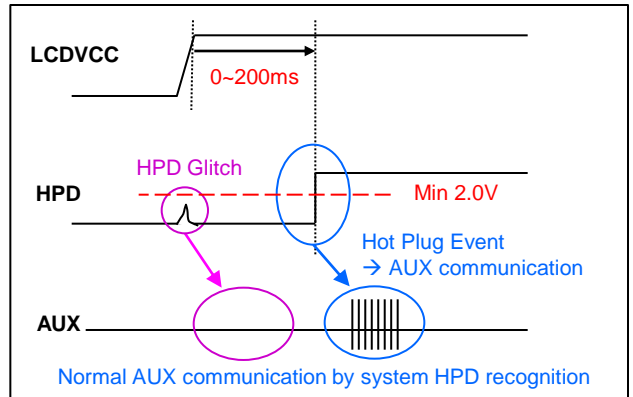

**[ Normal Communication By HPD Signal ]**

- Define**
1. Hot Plug Detection (HPD) Threshold level of Source Device is minimum 2.0V
  2. HPD Unplug : HPD pulse stays low longer than 2ms.  
DP Tx shall wait for HPD signal to go high again.
  3. "HPD High" is confirmed only after HPD has been asserted continuously for 100msec.

**2 IRQ (Interrupt Request) HPD Pulse Definition**

Ex) HPD Pulse

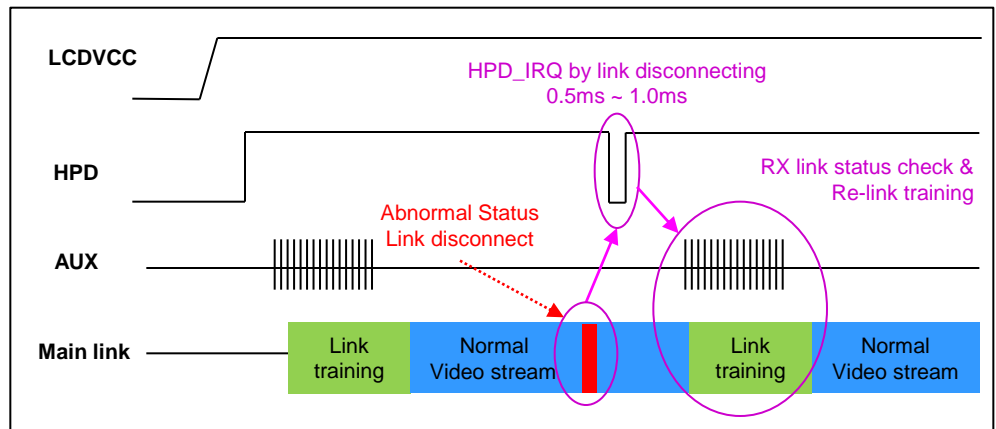

- Define**
- Upon detection this "HPD IRQ Event"(0.5ms ~ 1ms) ,the source device must read the link / sink status field of the DPCD and take corrective action.

**APPENDIX B. LGD Proposal for eDP Interface Design Guide**

**3 Main Link EYE Diagram**

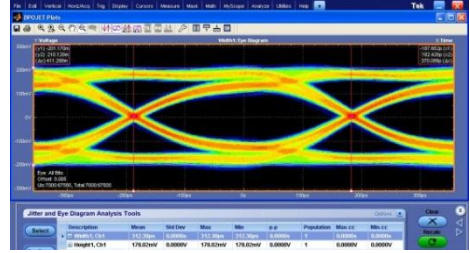
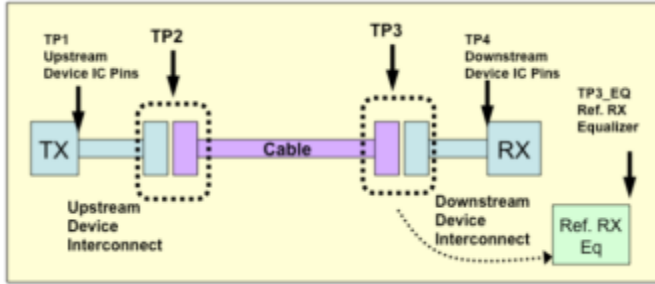

**[EYE Diagram]**

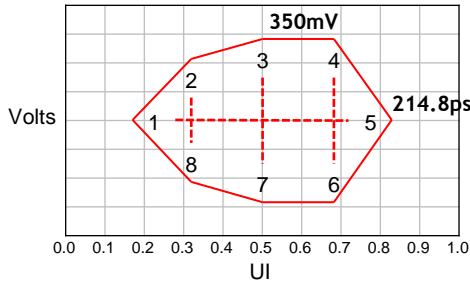

Point	UI	Voltage (Volts)
1	0.210	0.000
2	0.355	0.140
3	0.500	0.175
4	0.645	0.175
5	0.790	0.000
6	0.645	-0.175
7	0.500	-0.175
8	0.355	-0.140

**[EYE Vertices for TP2 at HBR]**

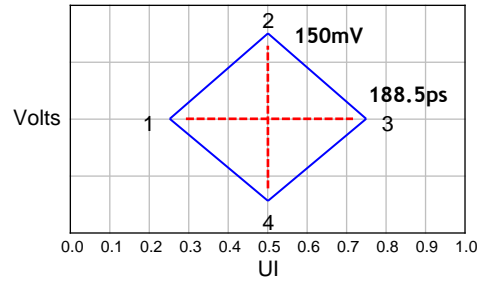

Point	UI	Voltage (Volts)
1	0.246	0.000
2	0.500	0.075
3	0.755	0.000
4	0.500	-0.075

**[EYE Vertices for TP3 at HBR]**

Define Main Link EYE Diagram should meet TP2 and TP3 point

**4 Cable Impedance management**

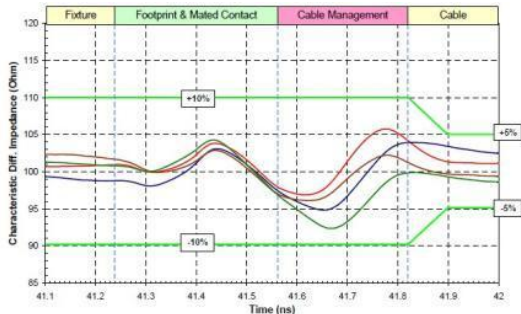

Segment	Differential Impedance	Maximum Tolerance
Fixture	100 Ω	+/- 10%
Connector	100 Ω	
Wire management	100 Ω	
Cable	100 Ω	+/- 5%

Define Cable Impedance 100 Ω +/- 5% ( 95Ω ~ 105Ω )

APPENDIX B. LGD Proposal for eDP Interface Design Guide

5 Main Link Off vs. LCD Power Off at Non-PSR

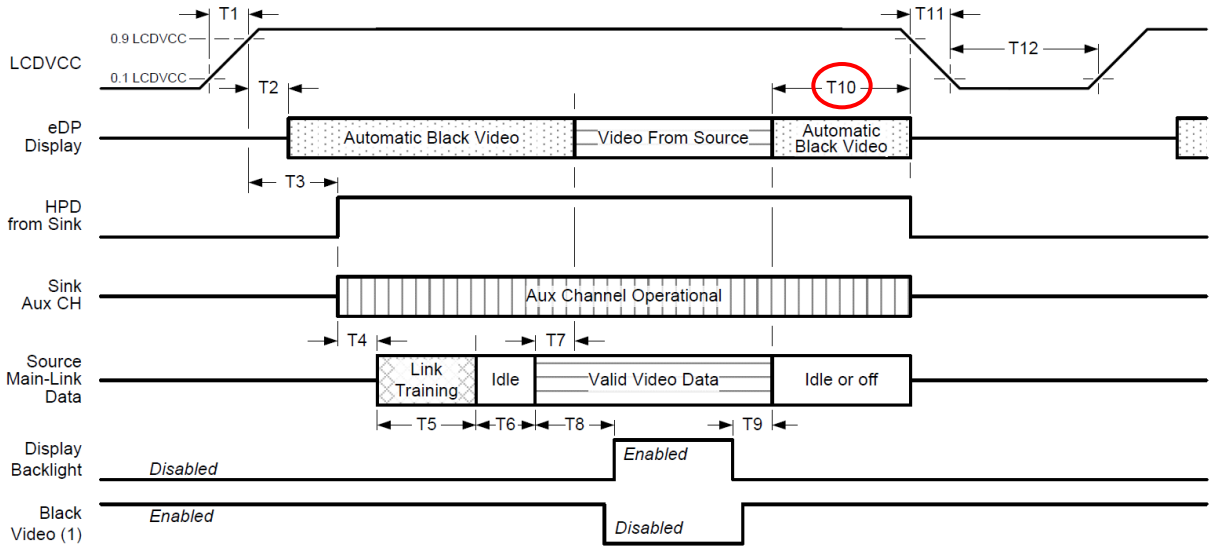

Timing Parameter	Description	Required By	Min	Max
T10	Delay from end of valid video from Source to Power Off	Source	0ms	500ms

\* LGD recommend that Source must power off the LCDVCC if Main Link off like below.



[Case1. Resolution Change]

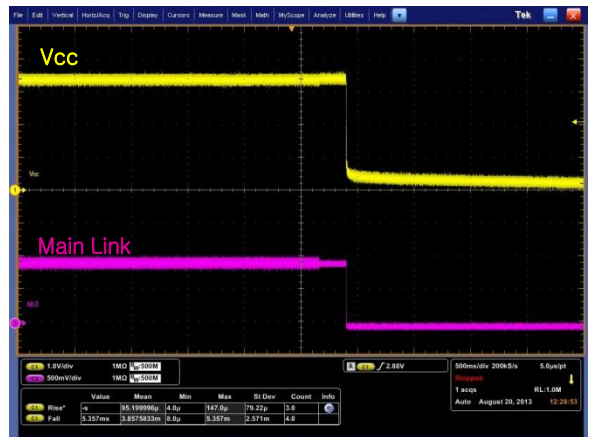

[Case2. Close the Lid]

Define

If Main Link off signal from Source, then LCDVCC must be Power Off within T10 period at Non-PSR mode

APPENDIX B. LGD Proposal for eDP Interface Design Guide

6 PSR Exit

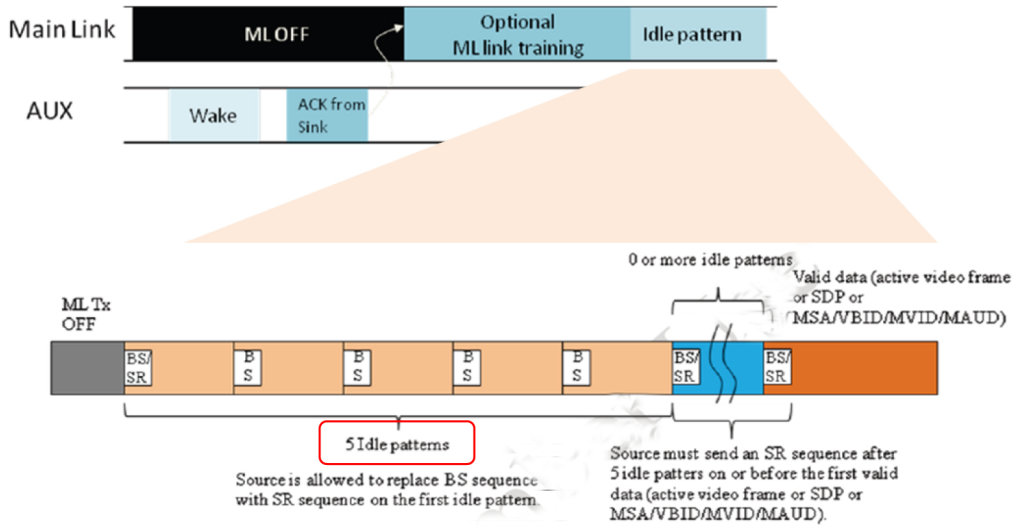

Define Source must send 5 or more idle patterns before the first valid data (active video frame or SDP or MSA/VBID/MVID/MAUD)

7 Main Link Noise at PSR Exit

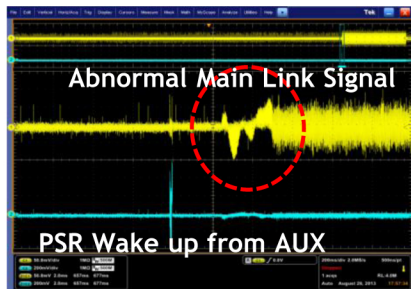

[ Abnormal Main Link Noise ]



[ Normal Main Link Signal ]

Define Main Link Noise at PSR Exit mode can be a cause abnormal display.

**APPENDIX C. Enhanced Extended Display Identification Data (EEDID™) 1/3**

**APPENDIX C. Enhanced Extended Display Identification Data (EEDID™) 2/3**

**APPENDIX C. Enhanced Extended Display Identification Data (EEDID™) 3/3**