

Product Specification

SPECIFICATION FOR APPROVAL

- (◆) Preliminary Specification
- () Final Specification

Title	17.1" WSXGA+ TFT LCD
-------	----------------------

BUYER	
MODEL	

SUPPLIER	LG.Philips LCD Co., Ltd.
*MODEL	LP171W02
Suffix	A4

*When you obtain standard approval, please use the above model name without suffix

SIGNATURE	DATE
/	_____
/	_____
/	_____

Please return 1 copy for your confirmation with your signature and comments.

SIGNATURE	DATE
S.C. Yoon / G.Manager	_____
REVIEWED BY	
J.K. Kim / Manager	
/ Manager	
PREPARED BY	
K.T. Moon / Engineer	
/ Engineer	

Products Engineering Dept.
LG. Philips LCD Co., Ltd

Product Specification

Contents

No	ITEM	Page
	COVER	1
	CONTENTS	2
	RECORD OF REVISIONS	3
1	GENERAL DESCRIPTION	4
2	ABSOLUTE MAXIMUM RATINGS	5
3	ELECTRICAL SPECIFICATIONS	
3-1	ELECTRICAL CHARACTERISTICS	6
3-2	INTERFACE CONNECTIONS	8
3-3	SIGNAL TIMING SPECIFICATIONS	9
3-4	SIGNAL TIMING WAVEFORMS	9
3-5	COLOR INPUT DATA REFERNECE	10
3-6	POWER SEQUENCE	11
4	OPTICAL SPECIFICATIONS	12
5	MECHANICAL CHARACTERISTICS	16
6	RELIABILITY	20
7	INTERNATIONAL STANDARDS	
7-1	SAFETY	21
7-2	EMC	21
8	PACKING	
8-1	DESIGNATION OF LOT MARK	22
8-2	PACKING FORM	22
9	PRECAUTIONS	23
A	APPENDIX A. Enhanced Extended Display Identification Data	25
B	APPENDIX B. Inspection Criteria	28

Product Specification

1. General Description

The LP171W02(A4) is a Color Active Matrix Liquid Crystal Display with an integral Cold Cathode Fluorescent Lamp (CCFL) backlight system. The matrix employs a-Si Thin Film Transistor as the active element. It is a transmissive type display operating in the normally white mode. This TFT-LCD has 17.1 inches diagonally measured active display area with WSXGA+ resolution(1050 vertical by 1680 horizontal pixel array). Each pixel is divided into Red, Green and Blue sub-pixels or dots which are arranged in vertical stripes. Gray scale or the brightness of the sub-pixel color is determined with a 6-bit gray scale signal for each dot, thus, presenting a palette of more than 262,144 colors.

The LP171W02(A4) has been designed to apply the interface method that enables low power, high speed, low EMI.

The LP171W02(A4) is intended to support applications where thin thickness, low power are critical factors and graphic displays are important. In combination with the vertical arrangement of the sub-pixels, the LP171W02(A4) characteristics provide an excellent flat display for office automation products such as Notebook PC.

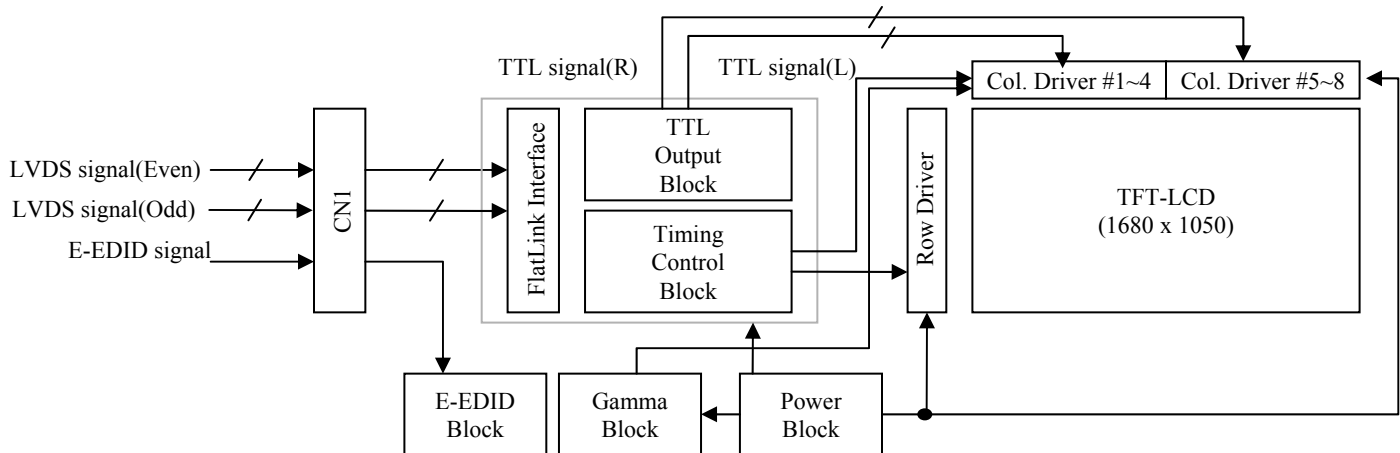

General Features

Active Screen Size	17.1 inches diagonal
Outline Dimension	382.2(H)[typ.] × 244.5(V)[typ.] × 6.9(D) mm [Max.]
Pixel Pitch	0.0729 mm × 0.2187 mm
Pixel Format	1680 horiz. By 1050 vert. Pixels RGB strip arrangement
Color Depth	6-bit, 262,144 colors
Luminance, White	170 cd/m ² [typ.], 5p average
Power Consumption	Total 6.46 Watt(Typ.) @ LCM circuit 1.68 Watt(Typ.), B/L input 4.78 Watt(Typ.)
Weight	755g [Max.]
Display Operating Mode	Transmissive mode, normally white
Surface Treatment	Hard coating(2H) Glare + Anti reflective treatment of the front polarizer

Product Specification

2. Absolute Maximum Ratings

The following are maximum values which, if exceeded, may cause faulty operation or damage to the unit.

Table 1. ABSOLUTE MAXIMUM RATINGS

Parameter	Symbol	Values		Units	Notes
		Min	Max		
Power Input Voltage	VCC	-0.3	4.0	Vdc	at 25 ± 5°C
Operating Temperature	TOP	0	50	°C	1
Storage Temperature	HST	-20	60	°C	1
Operating Ambient Humidity	HOP	10	90	%RH	1
Storage Humidity	HST	10	90	%RH	1

Note : 1. Temperature and relative humidity range are shown in the figure below.
 Wet bulb temperature should be 39°C Max, and no condensation of water.

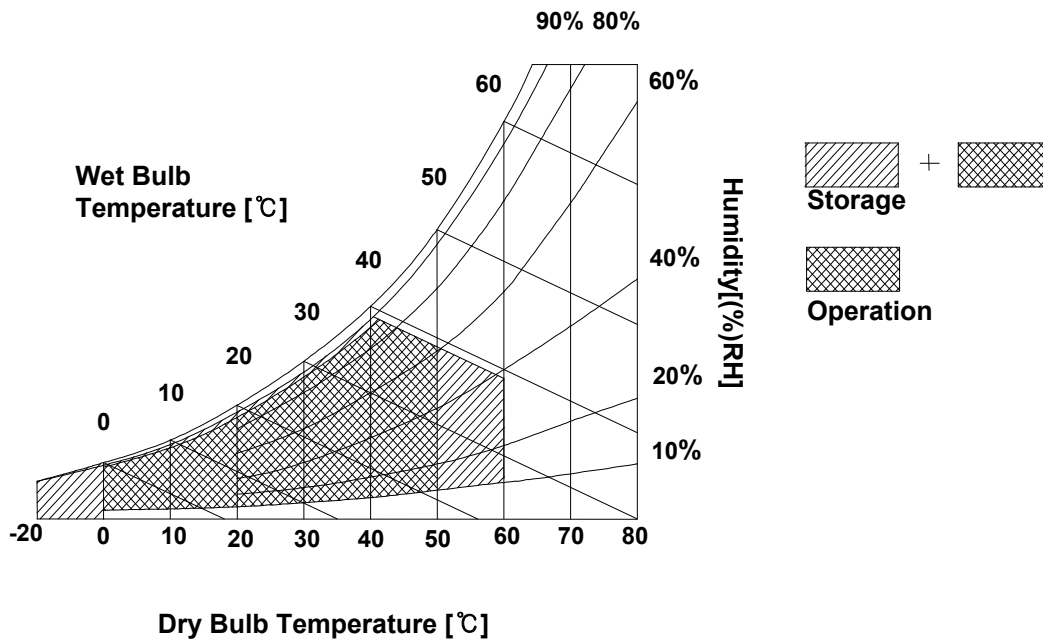

Product Specification

3. Electrical Specifications

3-1. Electrical Characteristics

The LP171W02(A4) requires two power inputs. One is employed to power the LCD electronics and to drive the TFT array and liquid crystal. The second input which powers the CCFL, is typically generated by an inverter. The inverter is an external unit to the LCD.

Table 2. ELECTRICAL CHARACTERISTICS

Parameter	Symbol	Values			Unit	Notes
		Min	Typ	Max		
MODULE :						
Power Supply Input Voltage	VCC	3.0	3.3	3.6	V _{dc}	
Power Supply Input Current	I _{CC}	-	510	620	mA	1
Power Consumption	P _c	-	1.68	2.05	Watts	1
Differential Impedance	Z _m	90	100	110	Ohm	2
LAMP :						
Operating Voltage	V _{BL}	714(6.8mA)	735(6.5mA)	920(3.0mA)	V _{RMS}	3
Operating Current	I _{BL}	3.0	6.5	6.8	mA _{RMS}	4
Power Consumption	P _{BL}	-	4.78	5.2		I _{bl} =6.5mA
Operating Frequency	f _{BL}	45	60	80	kHz	7
Discharge Stabilization Time	T _s	-	-	3	Min	5
Life Time		10,000	-	-	Hrs	6
Established Starting Voltage at 25°C at 0 °C	V _s			1200 1560	V _{RMS} V _{RMS}	8

Note)

- The specified current and power consumption are under the Vcc = 3.3V , 25°C , fv = 60Hz condition whereas full mosaic pattern is displayed and fv is the frame frequency.
The specified max current and power consumption are under the VCC=3.3V, 25°C, fv=60Hz condition whereas black pattern is displayed and fv is the frame frequency.
- This impedance value is needed to proper display and measured form LVDS Tx to the mating connector.
- The variance of the voltage is ± 10%.
- The typical operating current is for the typical surface luminance (L_{WH}) in optical characteristics.
- Define the brightness of the lamp after being lighted for 5 minutes as 100%, Ts is the time required for the brightness of the center of the lamp to be not less than 95%.
- The life time is determined as the time at which brightness of lamp is 50% compare to that of initial value at the typical lamp current.
- The output of the inverter must have symmetrical(negative and positive) voltage waveform and symmetrical current waveform.(Asymmetrical ratio is less than 10%) Please do not use the inverter which has asymmetrical voltage and asymmetrical current and spike wave.
Lamp frequency may produce interface with horizontal synchronous frequency and as a result this may cause beat on the display. Therefore lamp frequency shall be as away possible from the horizontal synchronous frequency and from its harmonics in order to prevent interference.
- The voltage above VS should be applied to the lamps for more than 1 second for start-up. Otherwise, the lamps may not be turned on. The used lamp current is the lamp typical current.
- The lamp power consumption shown above does not include loss of external inverter.
The applied lamp current is a typical one.

Product Specification

Note)

9. Requirements for a system inverter design, which is intended to have a better display performance, a better power efficiency and a more reliable lamp, are following.

It shall help increase the lamp lifetime and reduce leakage current.

- a. The asymmetry rate of the inverter waveform should be less than 10%.
- b. The distortion rate of the waveform should be within $\sqrt{2} \pm 10\%$.

* Inverter output waveform had better be more similar to ideal sine wave.

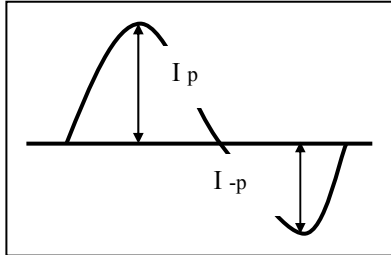

* Asymmetry rate:

$$|I_p - I_{-p}| / I_{rms} * 100\%$$

* Distortion rate

$$I_p \text{ (or } I_{-p}) / I_{rms}$$

※ Do not attach a conducting tape to lamp connecting wire.

If the lamp wire attach to a conducting tape, TFT-LCD Module has a low luminance and the inverter has abnormal action. Because leakage current is occurred between lamp wire and conducting tape.

Product Specification

3-2. Interface Connections

This LCD employs two interface connections, a 30 pin connector is used for the module electronics interface and the other connector is used for the integral backlight system.

The electronics interface connector is a model GT101-30S-HR11 manufactured by LGC.

Table 3. MODULE CONNECTOR PIN CONFIGURATION (CN1)

Pin	Symbol	Description	Notes
1	GND	Ground	<p>1. Interface chips 1.1 LCD : KZ4E053G11(LCD Controller) including LVDS Receiver (THINE, THC63LVD824) 1.2 System : THC63LVD823A or equivalent * Pin to Pin compatible with TI LVDS</p> <p>2. Connector 2.1 LCD : GT101-30S-HR11, LGC or its compatibles 2.2 Mating : FI-X30M or equivalent. 2.3 Connector pin arrangement</p>  <p>[LCD Module Rear View]</p>
2	VCC	Power Supply, 3.3V Typ.	
3	VCC	Power Supply, 3.3V Typ.	
4	V EEDID	DDC 3.3V power	
5	NC	Reserved for supplier test point	
6	Clk EEDID	DDC Clock	
7	DATA EEDID	DDC Data	
8	Odd_A1M	Dfferential data	
9	Odd_A1P	Dfferential data	
10	GND	Ground	
11	Odd_A2M	Dfferential data	
12	Odd_A2P	Dfferential data	
13	GND	Ground	
14	Odd_A3M	Dfferential data	
15	Odd_A3P	Dfferential data	
16	GND	Ground	
17	Odd_CLKM	Dfferential data	
18	Odd_CLKP	Dfferential data	
19	GND	Ground	
20	Even_A1M	Dfferential data	
21	Even_A1P	Dfferential data	
22	GND	Ground	
23	Even_A2M	Dfferential data	
24	Even_A2P	Dfferential data	
25	GND	Ground	
26	Even_A3M	Dfferential data	
27	Even_A3P	Dfferential data	
28	GND	Ground	
29	Even_CLKM	Dfferential data	
30	Even_CLKP	Dfferential data	

The backlight interface connector is a model BHSR-02VS-1, manufactured by JST or its compatibles . The mating connector part number is SM02B-BHSS-1 or equivalent.

Table 4. BACKLIGHT CONNECTOR PIN CONFIGURATION (J3)

Pin	Symbol	Description	Notes
1	HV	Power supply for lamp (High voltage side)	1
2	LV	Power supply for lamp (Low voltage side)	1

Notes : 1. The high voltage side terminal is colored pink and the low voltage side terminal is black.

Product Specification

3-3. Signal Timing Specifications

This is the signal timing required at the input of the User connector. All of the interface signal timing should be satisfied with the following specifications and specifications of LVDS Tx/Rx for it's proper operation.

Table 6. TIMING TABLE

ITEM	Symbol		Min	Typ	Max	Unit	Note
DCLK	Frequency	fCLK	55	61	69	MHz	
Hsync	Period	T _{hp}	880	952	1063	tCLK	
	Width	t _{WH}	8	-	-		
	Active	t _{WHA}	840	840	840		
Vsync	Period	t _{VP}	1057	1066	1082	tHP	
	Width	t _{WV}	1	-	-		
	Active	t _{WVA}	1050	1050	1050		
Data Enable	Horizontal back porch	t _{HBP}	16	-	-	tCLK	
	Horizontal front porch	t _{HFP}	16	-	-		
	Vertical back porch	t _{VBP}	5	-	-	tHP	
	Vertical front porch	t _{VFP}	1	-	-		

3-4. Signal Timing Waveforms

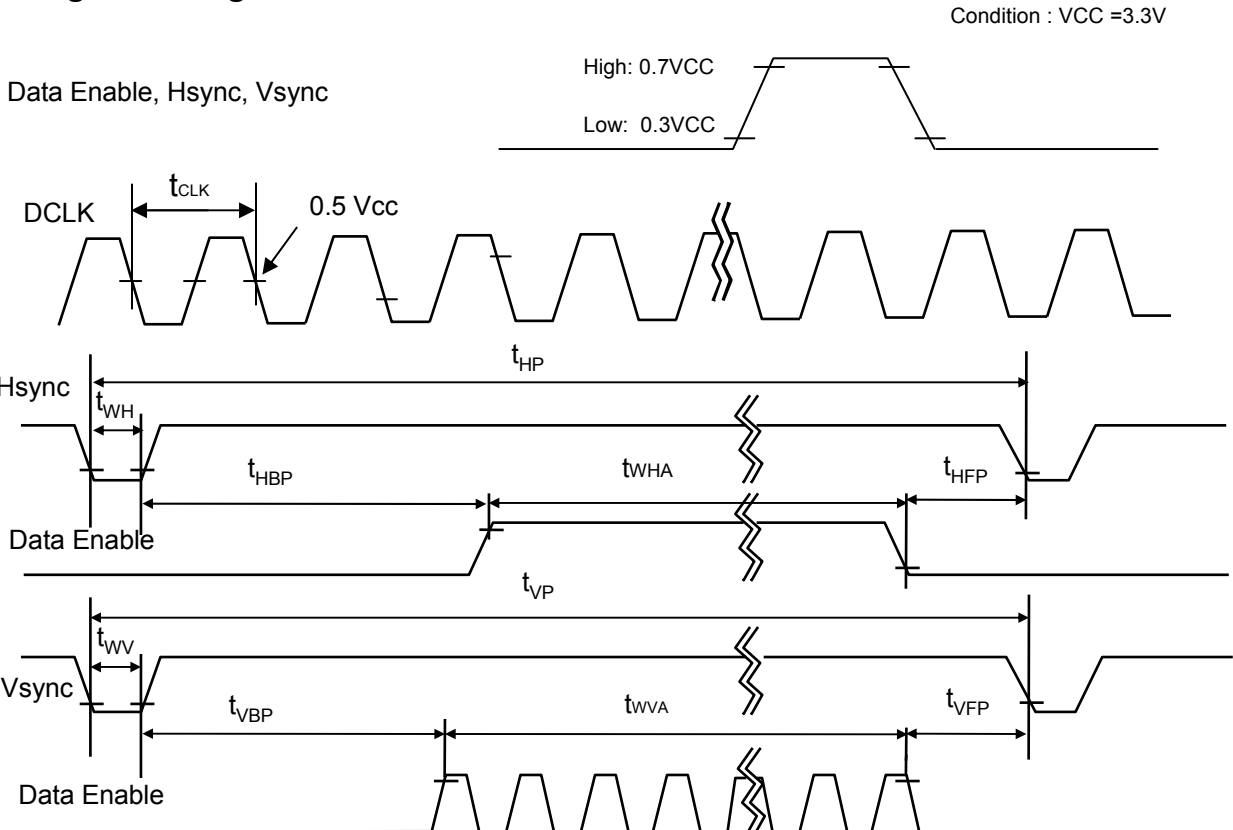

Product Specification

3-5. Color Input Data Reference

The brightness of each primary color (red, green and blue) is based on the 6-bit gray scale data input for the color ; the higher the binary input, the brighter the color. The table below provides a reference for color versus data input.

Table 7. COLOR DATA REFERENCE

Color		Input Color Data																					
		RED						GREEN						BLUE									
		MSB						LSB		MSB						LSB		MSB					
		R5	R4	R3	R2	R1	R0	G5	G4	G3	G2	G1	G0	B5	B4	B3	B2	B1	B0				
Basic Color	Black	0	0	0	0	0	0	0	0	0	0	0	0	0	0	0	0	0	0				
	Red	1	1	1	1	1	1	0	0	0	0	0	0	0	0	0	0	0	0				
	Green	0	0	0	0	0	0	1	1	1	1	1	1	0	0	0	0	0	0				
	Blue	0	0	0	0	0	0	0	0	0	0	0	0	1	1	1	1	1	1				
	Cyan	0	0	0	0	0	0	1	1	1	1	1	1	1	1	1	1	1	1				
	Magenta	1	1	1	1	1	1	0	0	0	0	0	0	1	1	1	1	1	1				
	Yellow	1	1	1	1	1	1	1	1	1	1	1	1	0	0	0	0	0	0				
	White	1	1	1	1	1	1	1	1	1	1	1	1	1	1	1	1	1	1				
RED	RED (00)	0	0	0	0	0	0	0	0	0	0	0	0	0	0	0	0	0	0				
	RED (01)	0	0	0	0	0	1	0	0	0	0	0	0	0	0	0	0	0	0				
									
	RED (62)	1	1	1	1	1	0	0	0	0	0	0	0	0	0	0	0	0	0				
	RED (63)	1	1	1	1	1	1	0	0	0	0	0	0	0	0	0	0	0	0				
GREEN	GREEN (00)	0	0	0	0	0	0	0	0	0	0	0	0	0	0	0	0	0	0				
	GREEN (01)	0	0	0	0	0	0	0	0	0	0	0	1	0	0	0	0	0	0				
									
	GREEN (62)	0	0	0	0	0	0	1	1	1	1	1	0	0	0	0	0	0	0				
	GREEN (63)	0	0	0	0	0	0	1	1	1	1	1	1	0	0	0	0	0	0				
BLUE	BLUE (00)	0	0	0	0	0	0	0	0	0	0	0	0	0	0	0	0	0	0				
	BLUE (01)	0	0	0	0	0	0	0	0	0	0	0	0	0	0	0	0	0	1				
									
	BLUE (62)	0	0	0	0	0	0	0	0	0	0	0	0	1	1	1	1	1	0				
	BLUE (63)	0	0	0	0	0	0	0	0	0	0	0	0	1	1	1	1	1	1				

Product Specification

3-6. Power Sequence

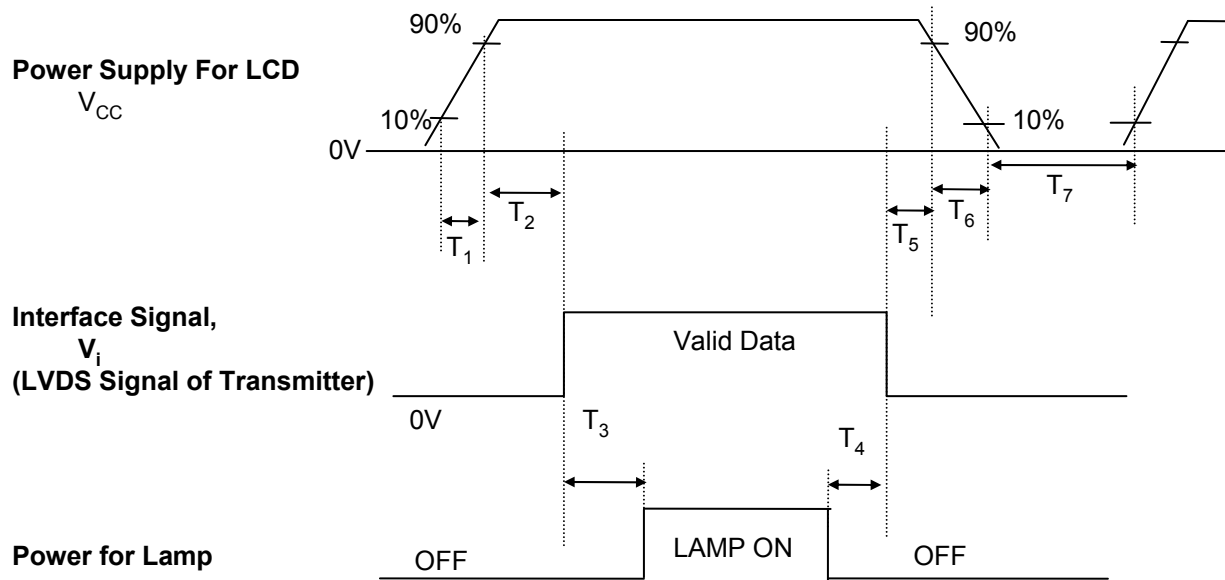

Table 8. POWER SEQUENCE TABLE

Parameter	Value			Units
	Min.	Typ.	Max.	
T_1	-	-	10	(ms)
T_2	0	-	50	(ms)
T_3	200	-	-	(ms)
T_4	200	-	-	(ms)
T_5	0	-	50	(ms)
T_6	0	-	10	(ms)
T_7	400	-	-	(ms)

Note)

1. Please avoid floating state of interface signal at invalid period.
2. When the interface signal is invalid, be sure to pull down the power supply for LCD VCC to 0V.
3. Lamp power must be turn on after power supply for LCD and interface signal are valid.

Product Specification

4. Optical Specification

Optical characteristics are determined after the unit has been 'ON' and stable for approximately 30 minutes in a dark environment at 25°C. The values specified are at an approximate distance 50cm from the LCD surface at a viewing angle of Φ and Θ equal to 0°.

FIG. 1 presents additional information concerning the measurement equipment and method.

FIG. 1 Optical Characteristic Measurement Equipment and Method

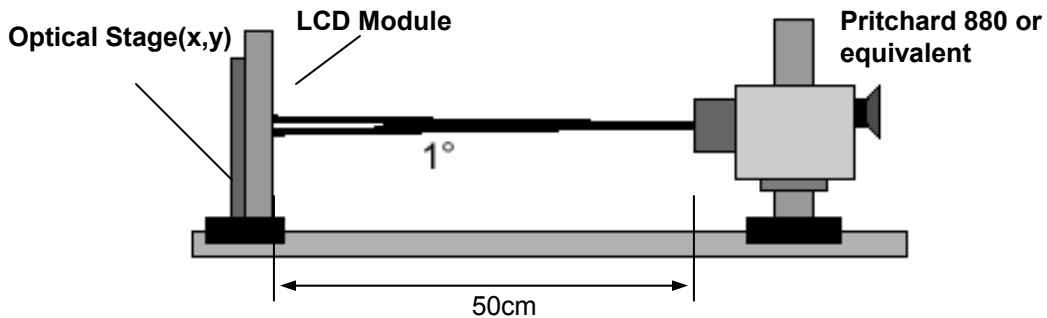

Table 9. OPTICAL CHARACTERISTICS

Ta=25°C, VCC=3.3V, fv=60Hz, fCLK= 61MHz, Iout = 6.5mA

Parameter	Symbol	Values			Units	Notes
		Min	Typ	MAX		
Contrast Ratio	CR	300	400	-		1
Surface Luminance, white	L _{WH}	145	170	-	cd/m ²	2
Luminance Variation	δ_{WHITE}	-	-	1.6		3
Response Time						4
Rise Time+Decay Time	Tr _R +Tr _D	-	25	40	ms	
Color Coordinates						±0.03
RED	RX	0.564	0.594	0.624		
	RY	0.316	0.346	0.376		
GREEN	GX	0.287	0.317	0.347		
	GY	0.520	0.550	0.580		
BLUE	BX	0.131	0.161	0.191		
	BY	0.119	0.149	0.179		
WHITE	WX	0.283	0.313	0.343		
	WY	0.299	0.329	0.359		
Viewing Angle						5
x axis, right($\Phi=0^\circ$)	Θ_r	65	70	-	degree	
x axis, left ($\Phi=180^\circ$)	Θ_l	65	70	-	degree	
y axis, up ($\Phi=90^\circ$)	Θ_u	50	55	-	degree	
y axis, down ($\Phi=270^\circ$)	Θ_d	50	55	-	degree	
Gray Scale			-			6

Product Specification

Note)

1. Contrast Ratio(CR) is defined mathematically as

$$\text{Contrast Ratio} = \frac{\text{Surface Luminance with all white pixels}}{\text{Surface Luminance with all black pixels}}$$

2. Surface luminance is the average of 5 point across the LCD surface 50cm from the surface with all pixels displaying white. For more information see FIG 1.

$$L_{WH} = \text{Average}(L_1, L_2, \dots L_5)$$

3. The variation in surface luminance , The panel total variation (δ_{WHITE}) is determined by measuring L_N at each test position 1 through 13 and then defined as followed numerical formula.
For more information see FIG 2.

$$\delta_{WHITE} = \frac{\text{Maximum}(L_1, L_2, \dots L_{13}) - \text{Minimum}(L_1, L_2, \dots L_{13})}{\text{Maximum}(L_1, L_2, \dots L_{13})} \times 100$$

4. Response time is the time required for the display to transition from white to black (rise time, Tr_R) and from black to white(Decay Time, Tr_D). For additional information see FIG 3.

5. Viewing angle is the angle at which the contrast ratio is greater than 10. The angles are determined for the horizontal or x axis and the vertical or y axis with respect to the z axis which is normal to the LCD surface. For more information see FIG 4.

6. Gray scale specification

* $f_V = 60\text{Hz}$

Gray Level	Luminance [%] (Typ)
L0	0.14
L7	0.59
L15	3.38
L23	9.86
L31	21.73
L39	39.23
L47	61.53
L55	84.59
L63	100

Product Specification

FIG. 2 Luminance

<measuring point for surface luminance & measuring point for luminance variation>

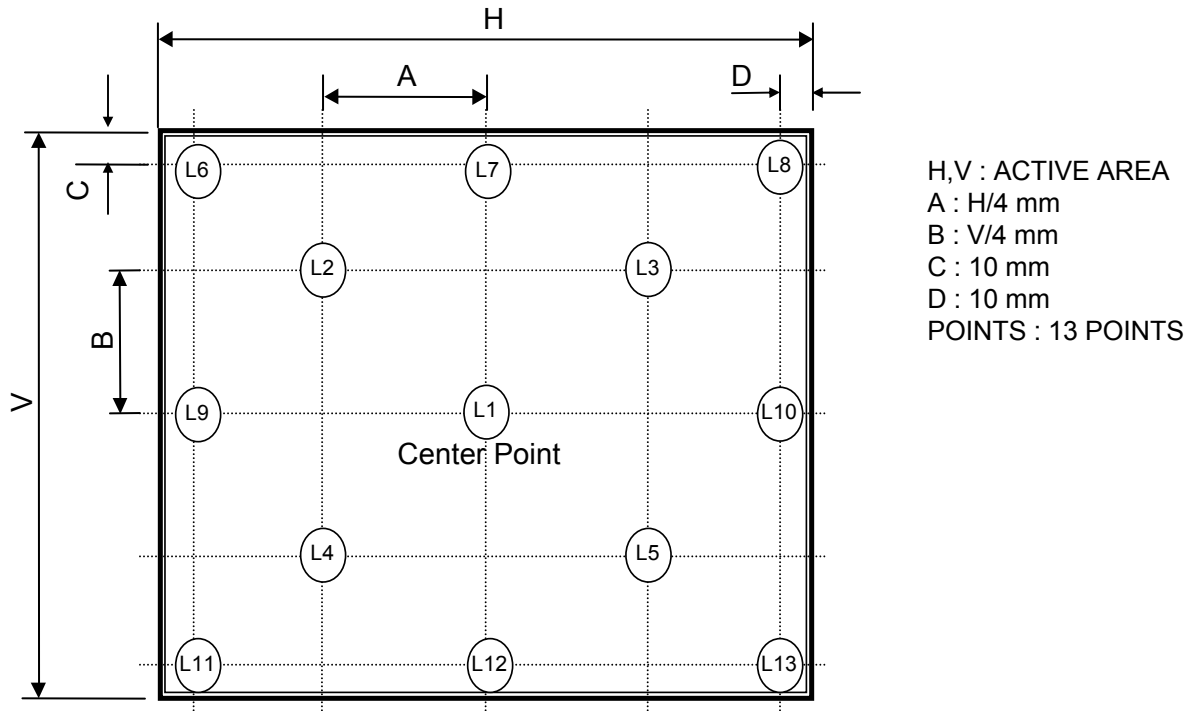
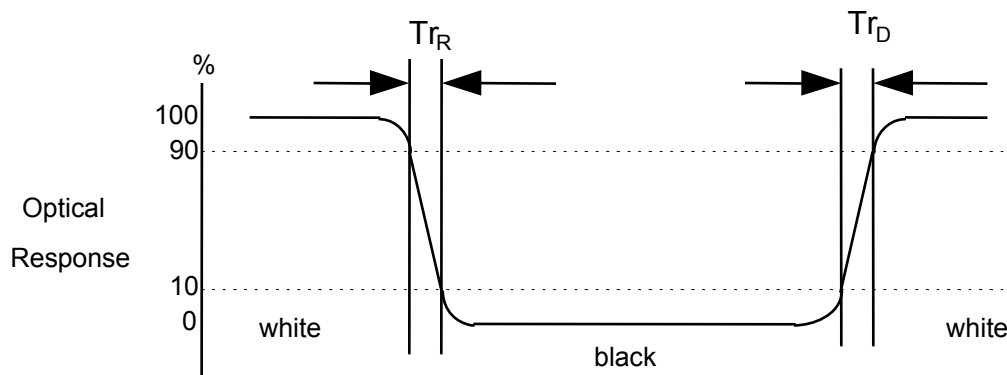

FIG. 3 Response Time

The response time is defined as the following figure and shall be measured by switching the input signal for “black” and “white”.



Product Specification

FIG. 4 Viewing angle

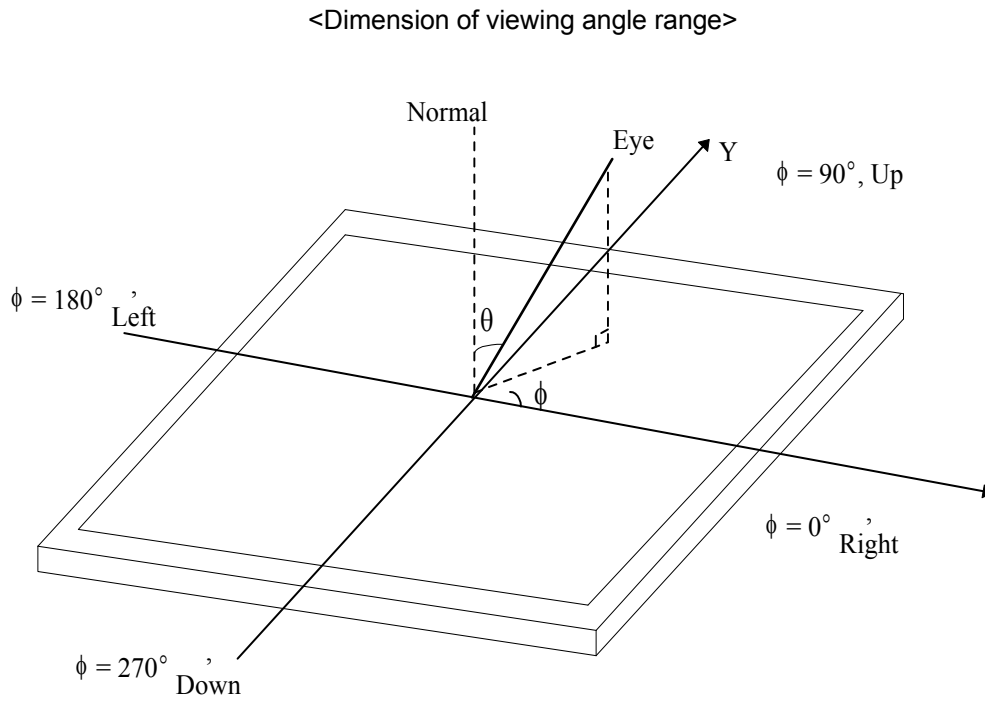

Product Specification

5. Mechanical Characteristics

The contents provide general mechanical characteristics for the model LP171W02(A4). In addition the figures in the next page are detailed mechanical drawing of the LCD.

Outline Dimension	Horizontal	382.2 ± 0.5mm
	Vertical	244.5 ± 0.5mm
	Depth	6.6mm(Typ.),6.9mm(Max.)
Bezel Area	Horizontal	370.6 ± 0.5mm
	Vertical	232.9 ± 0.5mm
Active Display Area	Horizontal	367.42 mm
	Vertical	229.64 mm
Weight	755g(Max.)	
Surface Treatment	Hard coating(2H) Glare + Anti reflective treatment of the front polarizer	

Product Specification

<FRONT VIEW>

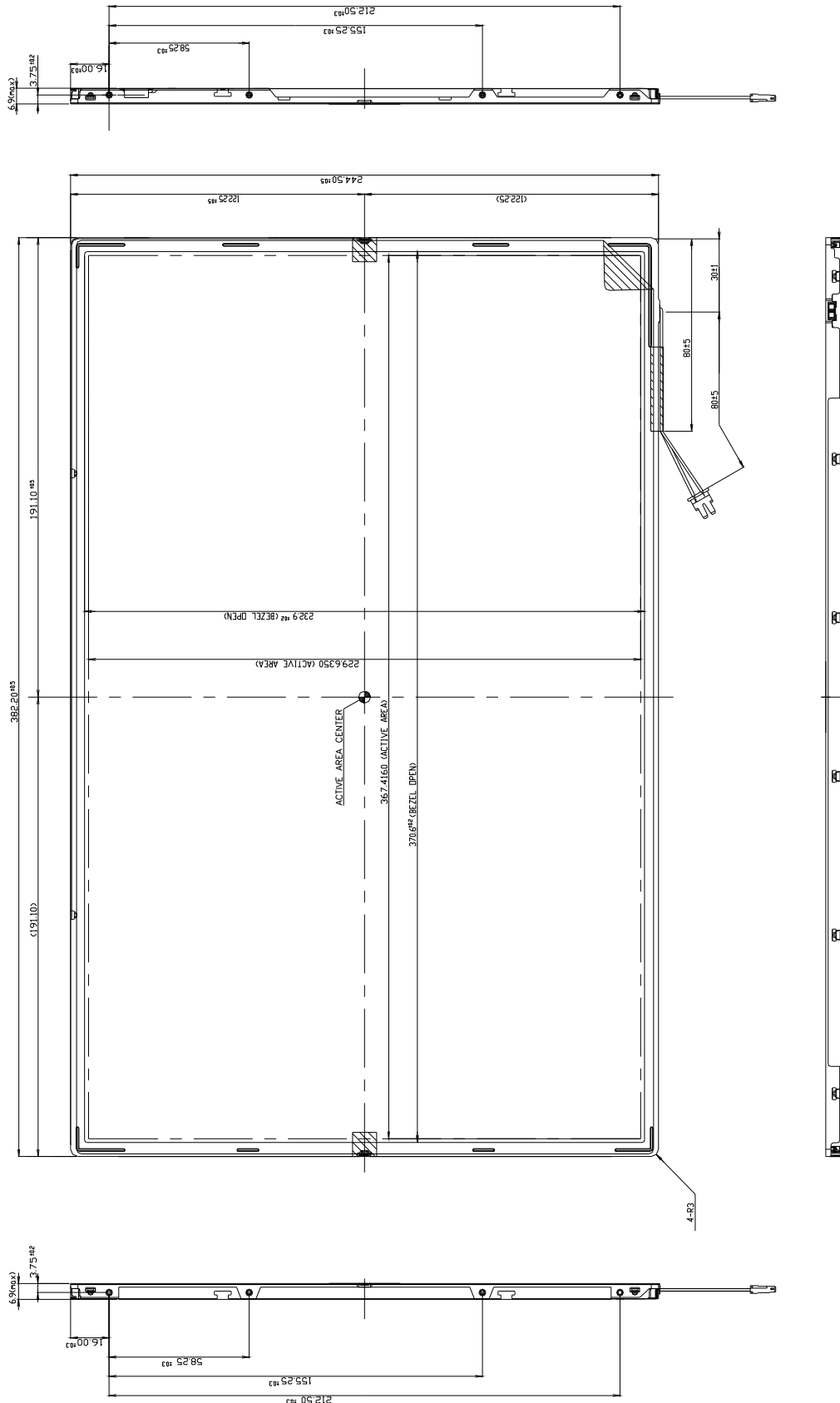

Product Specification

<REAR VIEW>

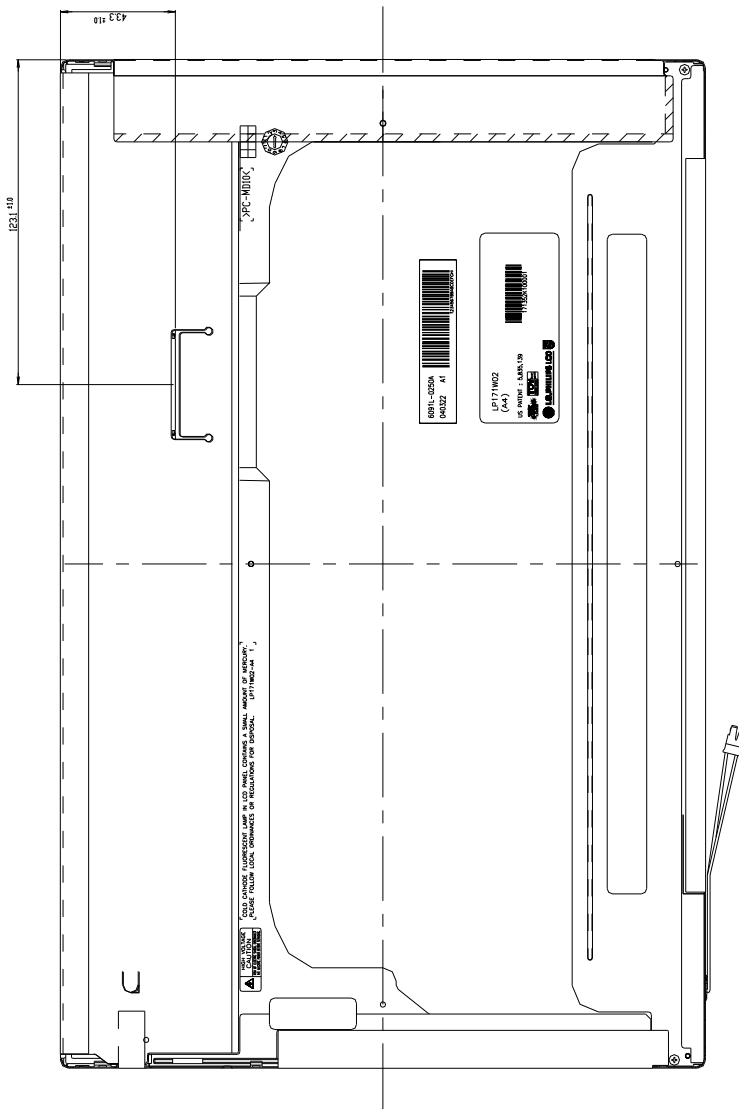

- Notes : 1 unspecified dimensional tolerance are +/-0.5mm
 2. Tilt and partial disposition tolerance of display area as following.
 (1) Y-Direction : $|A-B| \leq 1.0$
 (2) X-Direction : $|A-B| \leq 1.0$

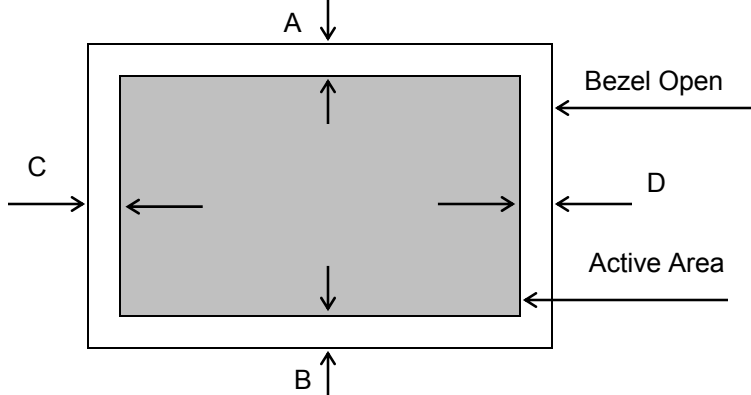

Product Specification

<DETAIL DESCRIPTION OF SIDE MOUNTING SCREW>

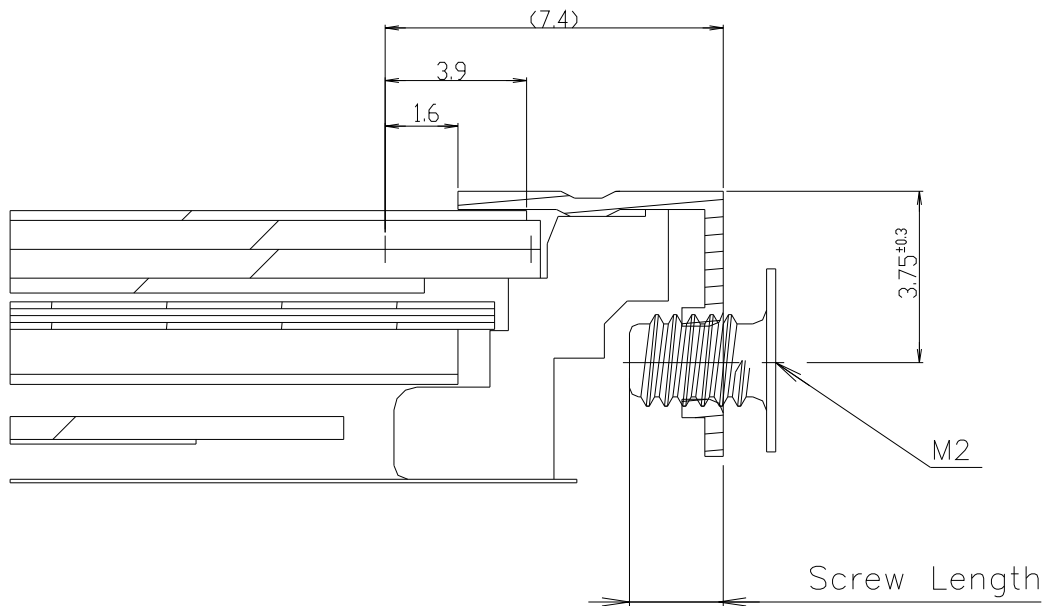

- * Screw Length : Left and Right (Max : 2.5, Min : 2.0)
- * Screw Torque : Max 2.0kgf cm

Notes : 1. Screw plated through the method of non-electrolytic nickel plating is preferred to reduce possibility that results in vertical and/or horizontal line defect due to the conductive particles from screw surface.

Product Specification

6. Reliability

Environment test condition

No.	Test Item	Conditions
1	High temperature storage test	Ta= 60°C, 240h
2	Low temperature storage test	Ta= -20°C, 240h
3	High temperature operation test	Ta= 50°C, 50%RH, 240h
4	Low temperature operation test	Ta= 0°C, 240h
5	Vibration test (non-operating)	Sine wave, 10 ~ 500 ~ 10Hz, 1.5G, 0.37oct/min 3 axis, 1hour/axis
6	Shock test (non-operating)	Half sine wave, 180G, 2ms one shock of each six faces(i.e. run 180G 2ms for all six faces)
7	Altitude operating storage / shipment	0 ~ 10,000 feet (3,048m) 24Hr 0 ~ 40,000 feet (12,192m) 24Hr

{ Result Evaluation Criteria }

There should be no change which might affect the practical display function when the display quality test is conducted under normal operating condition.

Product Specification

7. International Standards

7-1. Safety

- a) UL 60950, Third Edition, Underwriters Laboratories, Inc., Dated Dec. 11, 2000.
Standard for Safety of Information Technology Equipment, Including Electrical Business Equipment.
- b) CAN/CSA C22.2, No. 60950, Third Edition, Canadian Standards Association, Dec. 1, 2000.
Standard for Safety of Information Technology Equipment, Including Electrical Business Equipment.
- c) EN 60950 : 2000, Third Edition
IEC 60950 : 1999, Third Edition
European Committee for Electrotechnical Standardization(CENELEC)
EUROPEAN STANDARD for Safety of Information Technology Equipment Including Electrical Business Equipment.

7-2. EMC

- a) ANSI C63.4 "Methods of Measurement of Radio-Noise Emissions from Low-Voltage Electrical and Electrical Equipment in the Range of 9kHz to 40GHz. "American National Standards Institute(ANSI), 1992
- b) C.I.S.P.R "Limits and Methods of Measurement of Radio Interface Characteristics of Information Technology Equipment." International Special Committee on Radio Interference.
- c) EN 55022 "Limits and Methods of Measurement of Radio Interface Characteristics of Information Technology Equipment." European Committee for Electrotechnical Standardization.(CENELEC), 1998
(Including A1: 2000)

Product Specification

8. Packing

8-1. Designation of Lot Mark

a) Lot Mark

A	B	C	D	E	F	G	H	I	J	K	L	M
---	---	---	---	---	---	---	---	---	---	---	---	---

A,B,C : SIZE(INCH)

D : YEAR

F : PANEL CODE

H : ASSEMBLY CODE

E : MONTH

G : FACTORY CODE

I,J,K,L,M : SERIAL NO.

Note

1. YEAR

Year	97	98	99	2000	2001	2002	2003	2004	2005	2006	2007
Mark	7	8	9	0	1	2	3	4	5	6	7

2. MONTH

Month	Jan	Feb	Mar	Apr	May	Jun	Jul	Aug	Sep	Oct	Nov	Dec
Mark	1	2	3	4	5	6	7	8	9	A	B	C

3. PANEL CODE

Panel Code	P1 Factory	P2 Factory	P3 Factory	P4 Factory	P5 Factory	Hydis Panel
Mark	1	2	3	4	5	H

4. FACTORY CODE

Factory Code	LPL Gumi	LPL Nanjing	Hee Sung
Mark	K	C	D

5. SERIAL NO.

Year	1 ~ 99999	100000 ~
Mark	00001 ~ 99999	A0001 ~ A9999, , Z9999

b) Location of Lot Mark

Serial NO. is printed on the label. The label is attached to the backside of the LCD module.
This is subject to change without prior notice.

8-2. Packing Form

a) Package quantity in one box : 10 pcs

b) Box Size : 490mm × 277mm × 322mm

Product Specification

9. PRECAUTIONS

Please pay attention to the following when you use this TFT LCD module.

9-1. MOUNTING PRECAUTIONS

- (1) You must mount a module using holes arranged in four corners or four sides.
- (2) You should consider the mounting structure so that uneven force(ex. Twisted stress) is not applied to the module.
And the case on which a module is mounted should have sufficient strength so that external force is not transmitted directly to the module.
- (3) Please attach a transparent protective plate to the surface in order to protect the polarizer.
Transparent protective plate should have sufficient strength in order to resist external force.
- (4) You should adopt radiation structure to satisfy the temperature specification.
- (5) Acetic acid type and chlorine type materials for the cover case are not described because the former generates corrosive gas of attacking the polarizer at high temperature and the latter causes circuit break by electro-chemical reaction.
- (6) Do not touch, push or rub the exposed polarizers with glass, tweezers or anything harder than HB pencil lead. And please do not rub with dust clothes with chemical treatment.
Do not touch the surface of polarizer for bare hand or greasy cloth.(Some cosmetics are determined to the polarizer.)
- (7) When the surface becomes dusty, please wipe gently with absorbent cotton or other soft materials like chamois soaks with petroleum benzene. Normal-hexane is recommended for cleaning the adhesives used to attach front / rear polarizers. Do not use acetone, toluene and alcohol because they cause chemical damage to the polarizer.
- (8) Wipe off saliva or water drops as soon as possible. Their long time contact with polarizer causes deformations and color fading.
- (9) Do not open the case because inside circuits do not have sufficient strength.

9-2. OPERATING PRECAUTIONS

- (1) The spike noise causes the mis-operation of circuits. It should be lower than following voltage :
 $V = \pm 200\text{mV}$ (Over and under shoot voltage)
- (2) Response time depends on the temperature.(In lower temperature, it becomes longer.)
- (3) Brightness depends on the temperature. (In lower temperature, it becomes lower.)
And in lower temperature, response time(required time that brightness is stable after turned on) becomes longer.
- (4) Be careful for condensation at sudden temperature change. Condensation makes damage to polarizer or electrical contacted parts. And after fading condensation, smear or spot will occur.
- (5) When fixed patterns are displayed for a long time, remnant image is likely to occur.
- (6) Module has high frequency circuits. Sufficient suppression to the electromagnetic interference shall be done by system manufacturers. Grounding and shielding methods may be important to minimize the interference.

Product Specification

9-3. ELECTROSTATIC DISCHARGE CONTROL

Since a module is composed of electronic circuits, it is not strong to electrostatic discharge. Make certain that treatment persons are connected to ground through wrist band etc. And don't touch interface pin directly.

9-4. PRECAUTIONS FOR STRONG LIGHT EXPOSURE

Strong light exposure causes degradation of polarizer and color filter.

9-5. STORAGE

When storing modules as spares for a long time, the following precautions are necessary.

- (1) Store them in a dark place. Do not expose the module to sunlight or fluorescent light. Keep the temperature between 5°C and 35°C at normal humidity.
- (2) The polarizer surface should not come in contact with any other object.
It is recommended that they be stored in the container in which they were shipped.

9-6. HANDLING PRECAUTIONS FOR PROTECTION FILM

- (1) When the protection film is peeled off, static electricity is generated between the film and polarizer. This should be peeled off slowly and carefully by people who are electrically grounded and with well ion-blown equipment or in such a condition, etc.
- (2) The protection film is attached to the polarizer with a small amount of glue. If some stress is applied to rub the protection film against the polarizer during the time you peel off the film, the glue is apt to remain on the polarizer.
Please carefully peel off the protection film without rubbing it against the polarizer.
- (3) When the module with protection film attached is stored for a long time, sometimes there remains a very small amount of glue still on the polarizer after the protection film is peeled off.
- (4) You can remove the glue easily. When the glue remains on the polarizer surface or its vestige is recognized, please wipe them off with absorbent cotton waste or other soft material like chamois soaked with normal-hexane.

Product Specification

APPENDIX A. Enhanced Extended Display Identification Data (EEDID™) 1/3

Byte# (decimal)	Byte# (HEX)	Field Name and Comments	Value			
			(HEX)	(binary)		
0	00	Header	0	0	0000 0000	Header
1	01	Header	F	F	1111 1111	
2	02	Header	F	F	1111 1111	
3	03	Header	F	F	1111 1111	
4	04	Header	F	F	1111 1111	
5	05	Header	F	F	1111 1111	
6	06	Header	F	F	1111 1111	
7	07	Header	0	0	0000 0000	
8	08	EISA manufacturer code(3 Character ID) = LGP	3	0	0011 0000	Vender/ Product ID
9	09	Compressed ASCII	F	0	1111 0000	
10	0A	Panel Supplier Reserved – Product code	0	0	0000 0000	
11	0B	(Hex, LSB first)	0	0	0000 0000	
12	0C	LCD Module Serial No. = 0 (If not used)	0	0	0000 0000	
13	0D	LCD Module Serial No. = 0 (If not used)	0	0	0000 0000	
14	0E	LCD Module Serial No. = 0 (If not used)	0	0	0000 0000	
15	0F	LCD Module Serial No. = 0 (If not used)	0	0	0000 0000	
16	10	Week of Manufacture = 00	0	0	0000 0000	
17	11	Year of Manufacture = 2003	0	D	0000 1101	
18	12	EDID Structure version # = 1	0	1	0000 0001	EDID Version/ Revision
19	13	EDID Revision # = 2	0	2	0000 0010	
20	14	Video Input Definition = Digital I/P, non TMDS CRGB	8	0	1000 0000	Display Parameter
21	15	Max H image size(cm)=36.7416cm(37)	2	5	0010 0101	
22	16	Max V image size(cm)=22.9635cm(23)	1	7	0001 0111	
23	17	Display gamma =2.2	7	8	0111 1000	
24	18	Feature support(DPMS) = Active off, RGB Color	0	A	0000 1010	
25	19	Red/Green low Bits	0	0	0000 0000	Color Characteristic
26	1A	Blue/White Low Bits	0	0	0000 0000	
27	1B	Red X =	0	0	0000 0000	
28	1C	Red Y =	0	0	0000 0000	
29	1D	Green X =	0	0	0000 0000	
30	1E	Green Y =	0	0	0000 0000	
31	1F	Blue X =	0	0	0000 0000	
32	20	Blue Y =	0	0	0000 0000	
33	21	White X = 0.313	5	0	0101 0000	
34	22	White Y = 0.329	5	4	0101 0100	
35	23	Established Timing I = 00h(If not used)	0	0	0000 0000	Established Timings
36	24	Established Timing II = 00h(If not used)	0	0	0000 0000	
37	25	Manufacturer's Timings = 00h(If not used)	0	0	0000 0000	
38	26	Standard Timing Identification 1 was not used	0	1	0000 0001	Standard Timing ID
39	27	Standard Timing Identification 1 was not used	0	1	0000 0001	
40	28	Standard Timing Identification 2 was not used	0	1	0000 0001	
41	29	Standard Timing Identification 2 was not used	0	1	0000 0001	
42	2A	Standard Timing Identification 3 was not used	0	1	0000 0001	
43	2B	Standard Timing Identification 3 was not used	0	1	0000 0001	
44	2C	Standard Timing Identification 4 was not used	0	1	0000 0001	
45	2D	Standard Timing Identification 4 was not used	0	1	0000 0001	
46	2E	Standard Timing Identification 5 was not used	0	1	0000 0001	
47	2F	Standard Timing Identification 5 was not used	0	1	0000 0001	
48	30	Standard Timing Identification 6 was not used	0	1	0000 0001	
49	31	Standard Timing Identification 6 was not used	0	1	0000 0001	
50	32	Standard Timing Identification 7 was not used	0	1	0000 0001	
51	33	Standard Timing Identification 7 was not used	0	1	0000 0001	
52	34	Standard Timing Identification 8 was not used	0	1	0000 0001	
53	35	Standard Timing Identification 8 was not used	0	1	0000 0001	

Product Specification

APPENDIX A. Enhanced Extended Display Identification Data (EEDID™) 2/3

Byte# (decimal)	Byte# (HEX)	Field Name and Comments	Value (HEX)	Value (binary)		
54	36	Pixel Clock/10,000 (LSB) => main clock = 122MHz	A 8	1010 1000	Timing Descriptor #1	
55	37	Pixel Clock/10,000 (MSB) / 1680 x 1050 @60Hz pixel clock = 60.9MHz	2 F	0010 1111		
56	38	Horizontal Active = 1680 pixels	9 0	1001 0000		
57	39	Horizontal Blanking = 224 pixels	E 0	1110 0000		
58	3A	Horizontal Active : Horizontal Blanking	6 0	0110 0000		
59	3B	Vertical Active = 1050 lines	1 A	0001 1010		
60	3C	Vertical Blanking = 16 lines	1 0	0001 0000		
61	3D	Vertical Active : Vertical Blanking	4 0	0100 0000		
62	3E	Horizontal Sync. Offset = 32 pixels	2 0	0010 0000		
63	3F	Horizontal Sync Pulse Width = 64 pixels	4 0	0100 0000		
64	40	Vertical Sync Offset = 1 lines : Sync Width = 3 lines	1 3	0001 0011		
65	41	Horizontal Vertical Sync Offset/Width upper 2bits = 0	0 0	0000 0000		
66	42	Horizontal Image Size = 36.7416cm(367)	6 F	0110 1111		
67	43	Vertical Image Size = 22.9635cm(230)	E 6	1110 0110		
68	44	Horizontal & Vertical Image Size	1 0	0001 0000		
69	45	Horizontal Border = 0	0 0	0000 0000		
70	46	Vertical Border = 0	0 0	0000 0000		
71	47	Non-interlaced, Normal display, no stereo, Digital separate sync, H/V pol negatives	1 9	0001 1001		
72	48	Flag	0 0	0000 0000		Timing Description #2
73	49	Flag	0 0	0000 0000		
74	4A	Flag	0 0	0000 0000		
75	4B	Data Type Tag : Descriptor Defined by Manufacturer	0 F	0000 1111		
76	4C	Flag	0 0	0000 0000		
77	4D	Value = HSPWmin/2 (pixel clks) 8	0 4	0000 0100		
78	4E	Value = HSPWmax/2 (pixel clks) 64	4 0	0100 0000		
79	4F	Value = Thbpmn/2 (pixel clks) 16	0 8	0000 1000		
80	50	Value = Thbpmx/2 (pixel clks) 128	8 0	1000 0000		
81	51	Value = VSPWmin/2 (line pulses) 1	0 1	0000 0001		
82	52	Value = VSPWmax/2 (line pulses) 3	0 3	0000 0011		
83	53	Value = Tvbpmin/2 (line pulses) 3	0 3	0000 0011		
84	54	Value = Tvbpmax/2 (line pulses) 12	0 C	0000 1100		
85	55	Thpmin = valueX2 + Hapixel clks (pixel clks) 40	2 8	0010 1000		
86	56	Thpmax = valueX2 + Hapixel clks (pixel clks) 224	E 0	1110 0000		
87	57	Tvpmin = valueX2 + VAlines (line pulses) 4	0 4	0000 0100		
88	58	Tvpmax = valueX2 + VAlines (line pulses) 16	1 0	0001 0000		
89	59	Module "A" Revision = 00	0 0	0000 0000	Timing Description #3	
90	5A	Detailed Timing Descriptor #3	0 0	0000 0000		
91	5B		0 0	0000 0000		
92	5C		0 0	0000 0000		
93	5D		F E	1111 1110		
94	5E		0 0	0000 0000		
95	5F	L	4 C	0100 1100		
96	60	P	5 0	0101 0000		
97	61	L	4 C	0100 1100		
98	62	LF	0 A	0000 1010		
99	63	SPACE	2 0	0010 0000		
100	64	SPACE	2 0	0010 0000		
101	65	SPACE	2 0	0010 0000		
102	66	SPACE	2 0	0010 0000		
103	67	SPACE	2 0	0010 0000		
104	68	SPACE	2 0	0010 0000		
105	69	SPACE	2 0	0010 0000		
106	6A	SPACE	2 0	0010 0000		
107	6B	SPACE	2 0	0010 0000		

Product Specification

APPENDIX A. Enhanced Extended Display Identification Data (EEDID™) 3/3

Byte# (decimal)	Byte# (HEX)	Field Name and Comments	Value (HEX)	Value (binary)	
108	6C	Detailed Timing Descriptor #4	0 0	0000 0000	Timing Description #4
109	6D		0 0	0000 0000	
110	6E		0 0	0000 0000	
111	6F		F E	1111 1110	
112	70		0 0	0000 0000	
113	71	L	4 C	0100 1100	
114	72	P	5 0	0101 0000	
115	73	1	3 1	0011 0001	
116	74	7	3 7	0011 0111	
117	75	1	3 1	0011 0001	
118	76	W	5 7	0101 0111	
119	77	0	3 0	0011 0000	
120	78	2	3 2	0011 0010	
121	79	LF	0 A	0000 1010	
122	7A	SPACE	2 0	0010 0000	
123	7B	SPACE	2 0	0010 0000	
124	7C	SPACE	2 0	0010 0000	
125	7D	SPACE	2 0	0010 0000	
126	7E	Extension flag = 00	0 0	0000 0000	Extension Flag
127	7F	Checksum	5 2	0101 0010	Checksum