

Product Specification

SPECIFICATION FOR APPROVAL

- () Preliminary Specification
(V) Final Specification

| | |
|-------|---------------------|
| Title | 17.1" WXGA+ TFT LCD |
|-------|---------------------|





| | |
|----------|------|
| Customer | Sony |
| MODEL | - |

| | |
|----------|--------------------------|
| SUPPLIER | LG.Philips LCD Co., Ltd. |
| *MODEL | LP171WP4 |
| Suffix | TL04 |

*When you obtain standard approval, please use the above model name without suffix

| SIGNATURE | DATE |
|-----------|-------|
| / | _____ |
| / | _____ |
| / | _____ |

Please return 1 copy for your confirmation with your signature and comments.

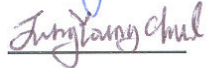
| APPROVED BY | SIGNATURE |
|----------------------|---|
| S.C. Yun / G.Manager |  |
| REVIEWED BY | |
| G. J. Han / Manager |  |
| C. Park / Manager |  |
| PREPARED BY | |
| B.T. Jang / Engineer |  |
| Y.C. Jung / Engineer |  |

Products Engineering Dept.
LG. Philips LCD Co., Ltd

Product Specification

Contents

| No | ITEM | Page |
|-----|---|------|
| | COVER | 1 |
| | CONTENTS | 2 |
| | RECORD OF REVISIONS | 3 |
| 1 | GENERAL DESCRIPTION | 4 |
| 2 | ABSOLUTE MAXIMUM RATINGS | 5 |
| 3 | ELECTRICAL SPECIFICATIONS | |
| 3-1 | ELECTRICAL CHARACTERISTICS | 6 |
| 3-2 | INTERFACE CONNECTIONS | 7 |
| 3-3 | SIGNAL TIMING SPECIFICATIONS | 9 |
| 3-4 | SIGNAL TIMING WAVEFORMS | 9 |
| 3-5 | COLOR INPUT DATA REFERENCE | 10 |
| 3-6 | POWER SEQUENCE | 11 |
| 4 | OPTICAL SPECIFICATIONS | 12 |
| 5 | MECHANICAL CHARACTERISTICS | 16 |
| 6 | RELIABILITY | 20 |
| 7 | INTERNATIONAL STANDARDS | |
| 7-1 | SAFETY | 21 |
| 7-2 | EMC | 21 |
| 8 | PACKING | |
| 8-1 | DESIGNATION OF LOT MARK | 22 |
| 8-2 | PACKING FORM | 22 |
| 9 | PRECAUTIONS | 23 |
| A | APPENDIX. Enhanced Extended Display Identification Data | 25 |

Product Specification

2. Absolute Maximum Ratings

The following are maximum values which, if exceeded, may cause faulty operation or damage to the unit.

Table 1. ABSOLUTE MAXIMUM RATINGS

| Parameter | Symbol | Values | | Units | Notes |
|----------------------------|--------|--------|-----|-------|-------------|
| | | Min | Max | | |
| Power Input Voltage | VCC | -0.3 | 4.0 | Vdc | at 25 ± 5°C |
| Operating Temperature | TOP | 0 | 50 | °C | 1 |
| Storage Temperature | HST | -20 | 60 | °C | 1 |
| Operating Ambient Humidity | HOP | 10 | 90 | %RH | 1 |
| Storage Humidity | HST | 10 | 90 | %RH | 1 |

Note : 1. Temperature and relative humidity range are shown in the figure below.
Wet bulb temperature should be 39°C Max, and no condensation of water.

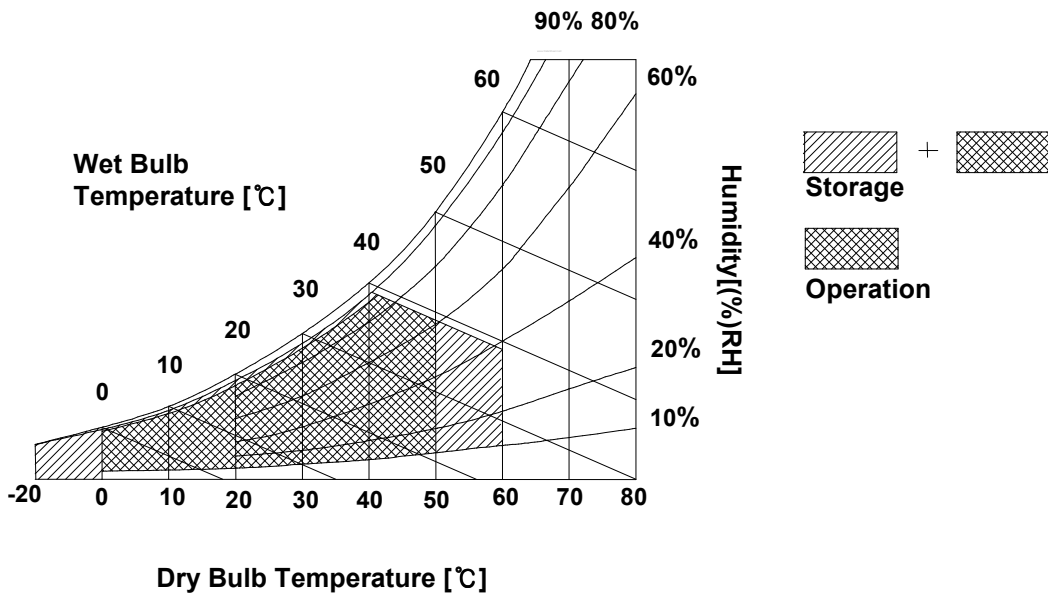

Product Specification

3. Electrical Specifications

3-1. Electrical Characteristics

The LP171WP4 requires two power inputs. One is employed to power the LCD electronics and to drive the TFT array and liquid crystal. The second input which powers the CCFL, is typically generated by an inverter. The inverter is an external unit to the LCD.

Table 2. ELECTRICAL CHARACTERISTICS

| Parameter | Symbol | Values | | | Unit | Notes |
|---|-------------------|----------------|----------------|----------------|--------------------------------------|-------|
| | | Min | Typ | Max | | |
| MODULE : | | | | | | |
| Power Supply Input Voltage | VCC | 3.0 | 3.3 | 3.6 | V _{DC} | 1 |
| Power Supply Input Current | I _{CC} | 415 | 490 | 560 | mA | 2 |
| Power Consumption | P _c | - | 1.62 | - | Watt | 2 |
| Differential Impedance | Z _m | 90 | 100 | 110 | Ohm | 3 |
| In-Rush Current | I _{rush} | - | - | 1.5 | A | |
| LAMP : | | | | | | |
| Operating Voltage | V _{BL} | 714 (6.8mA) | 735 (6.5mA) | 920 (3.0mA) | V _{RMS} | 4 |
| Operating Current | I _{BL} | 3.0 | 6.5 | 6.8 | mA _{RMS} | 5 |
| Power Consumption | P _{BL} | - | 4.78 | 5.25 | | 10 |
| Operating Frequency | f _{BL} | 40 | 60 | 70 | kHz | 8 |
| Discharge Stabilization Time | T _s | - | - | 3 | Min | 6 |
| Life Time | | 10,000 | - | - | Hrs | 7 |
| Established Starting Voltage at 25 °C at 0 °C | V _s | | | 1300 1500 | V _{RMS} V _{RMS} | 9 |

Note)

1. VCC Dip condition

1-1. When $2.7V \leq VCC < 3.0V$: $T_d \leq 10$ ms

1-2. When $VCC < 2.7V$: VCC Dip must be kept in “ 3-6. Power Sequence (page 11) “

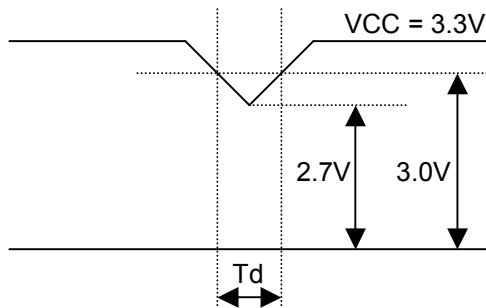

2. The specified current and power consumption are under the Vcc = 3.3V , 25 °C , fv = 60Hz condition whereas Mosaic pattern is displayed and fv is the frame frequency.

3. This impedance value is needed to proper display and measured form LVDS Tx to the mating connector.

Product Specification

Note)

4. The variance of the voltage is $\pm 10\%$.
5. The typical operating current is for the typical surface luminance (LWH) in optical characteristics.
6. Define the brightness of the lamp after being lighted for 5 minutes as 100%, T_s is the time required for the brightness of the center of the lamp to be not less than 95%.
7. The life time is determined as the time at which brightness of lamp is 50% compare to that of initial value at the typical lamp current.
8. The output of the inverter must have symmetrical(negative and positive) voltage waveform and symmetrical current waveform.(Asymmetrical ratio is less than 10%) Please do not use the inverter which has asymmetrical voltage and asymmetrical current and spike wave.
Lamp frequency may produce interface with horizontal synchronous frequency and as a result this may cause beat on the display. Therefore lamp frequency shall be as away possible from the horizontal synchronous frequency and from its harmonics in order to prevent interference.
9. The voltage above VS should be applied to the lamps for more than 1 second for start-up. Otherwise, the lamps may not be turned on. The used lamp current is the lamp typical current.
10. The lamp power consumption shown above does not include loss of external inverter.
The applied lamp current is a typical one.
11. Requirements for a system inverter design, which is intended to have a better display performance, a better power efficiency and a more reliable lamp, are following.
It shall help increase the lamp lifetime and reduce leakage current.
 - a. The asymmetry rate of the inverter waveform should be less than 10%.
 - b. The distortion rate of the waveform should be within $\sqrt{2} \pm 10\%$.
 * Inverter output waveform had better be more similar to ideal sine wave.

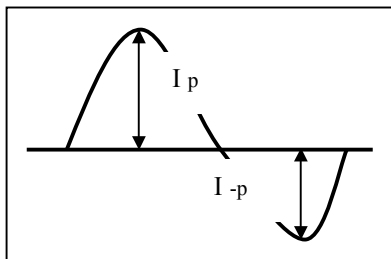

* Asymmetry rate:

$$\frac{|I_p - I_{-p}|}{I_{rms}} * 100\%$$

* Distortion rate

$$I_p \text{ (or } I_{-p}) / I_{rms}$$

※ Do not attach a conducting tape to lamp connecting wire.
 If the lamp wire attach to a conducting tape, TFT-LCD Module has a low luminance and the inverter has abnormal action. Because leakage current is occurred between lamp wire and conducting tape.

Product Specification

3-2. Interface Connections

This LCD employs two interface connections, a 30 pin connector is used for the module electronics interface and the other connector is used for the integral backlight system.

Table 3. MODULE CONNECTOR PIN CONFIGURATION (CN1)

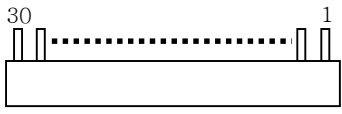
| Pin | Symbol | Description | Notes |
|-----|--------------------|---------------------------------------|--|
| 1 | GND | Ground | <p>1. Interface chips 1.1 LCD : KZ4E053G23(LCD Controller) including LVDS Receiver (THINE, THC63LVD824) 1.2 System : THC63LVDF823A or equivalent</p> <p>2. Connector 2.1 LCD : FI-XB30SRL-HF11(JAE) or its compatibles (LGC) 2.2 Mating : FI-X30M or equivalent. 2.3 Connector pin arrangement</p>  <p>[LCD Module Rear View]</p> |
| 2 | VCC | Power Supply, 3.3V Typ. | |
| 3 | VCC | Power Supply, 3.3V Typ. | |
| 4 | V EEDID | DDC 3.3V power | |
| 5 | NC | Reserved for supplier test point | |
| 6 | Clk EEDID | DDC Clock | |
| 7 | DATA EEDID | DDC Data | |
| 8 | R _{IN} 0- | Odd channel differential data input | |
| 9 | R _{IN} 0+ | Odd channel differential data input | |
| 10 | GND | Ground | |
| 11 | R _{IN} 1- | Odd channel differential data input | |
| 12 | R _{IN} 1+ | Odd channel differential data input | |
| 13 | GND | Ground | |
| 14 | R _{IN} 2- | Odd channel differential data input | |
| 15 | R _{IN} 2+ | Odd channel differential data input | |
| 16 | GND | Ground | |
| 17 | CLKIN- | Odd channel differential clock input | |
| 18 | CLKIN+ | Odd channel differential clock input | |
| 19 | GND | Ground | |
| 20 | RA2- | Even channel differential data input | |
| 21 | RA2+ | Even channel differential data input | |
| 22 | GND | Ground | |
| 23 | RB2- | Even channel differential data input | |
| 24 | RB2+ | Even channel differential data input | |
| 25 | GND | Ground | |
| 26 | RC2- | Even channel differential data input | |
| 27 | RC2+ | Even channel differential data input | |
| 28 | GND | Ground | |
| 29 | RCLK2- | Even channel differential clock input | |
| 30 | RCLK2+ | Even channel differential clock input | |

The backlight interface connector is a model BHSR-02VS-1, manufactured by JST or Compatible [(1674817-2(AMP))].

The mating connector part number is SM02B-BHSS-1-TB or equivalent [1-1565647-3(AMP)].

Table 5. BACKLIGHT CONNECTOR PIN CONFIGURATION (J3)

| Pin | Symbol | Description | Notes |
|-----|--------|---|-------|
| 1 | HV | Power supply for lamp (High voltage side) | 1 |
| 2 | LV | Power supply for lamp (Low voltage side) | 1 |

Notes : 1. The high voltage side terminal is colored dark gray and the low voltage side terminal is black.

Product Specification

3-3. Signal Timing Specifications

This is the signal timing required at the input of the User connector. All of the interface signal timing should be satisfied with the following specifications and specifications of LVDS Tx/Rx for its proper operation.

Table 6. TIMING TABLE

| ITEM | Symbol | Min | Typ | Max | Unit | Note | |
|-------------|------------------------|------------------|-----|------|------|------------------|-------------|
| DCLK | Frequency | f _{CLK} | 43 | 48.1 | 52 | MHz | 2Port input |
| Hsync | Period | t _{HP} | 793 | 880 | 938 | t _{CLK} | |
| | Width | t _{WH} | 8 | 16 | - | | |
| Vsync | Period | t _{VP} | 908 | 912 | 916 | t _{HP} | |
| | Width | t _{WV} | 2 | 3 | 3 | | |
| Data Enable | Horizontal back porch | t _{HBP} | 49 | 112 | - | t _{CLK} | |
| | Horizontal front porch | t _{HFP} | 16 | 32 | - | | |
| | Vertical back porch | t _{VBP} | 4 | 6 | 6 | t _{HP} | |
| | Vertical front porch | t _{VFP} | 2 | 3 | 3 | | |

3-4. Signal Timing Waveforms (Normal status)

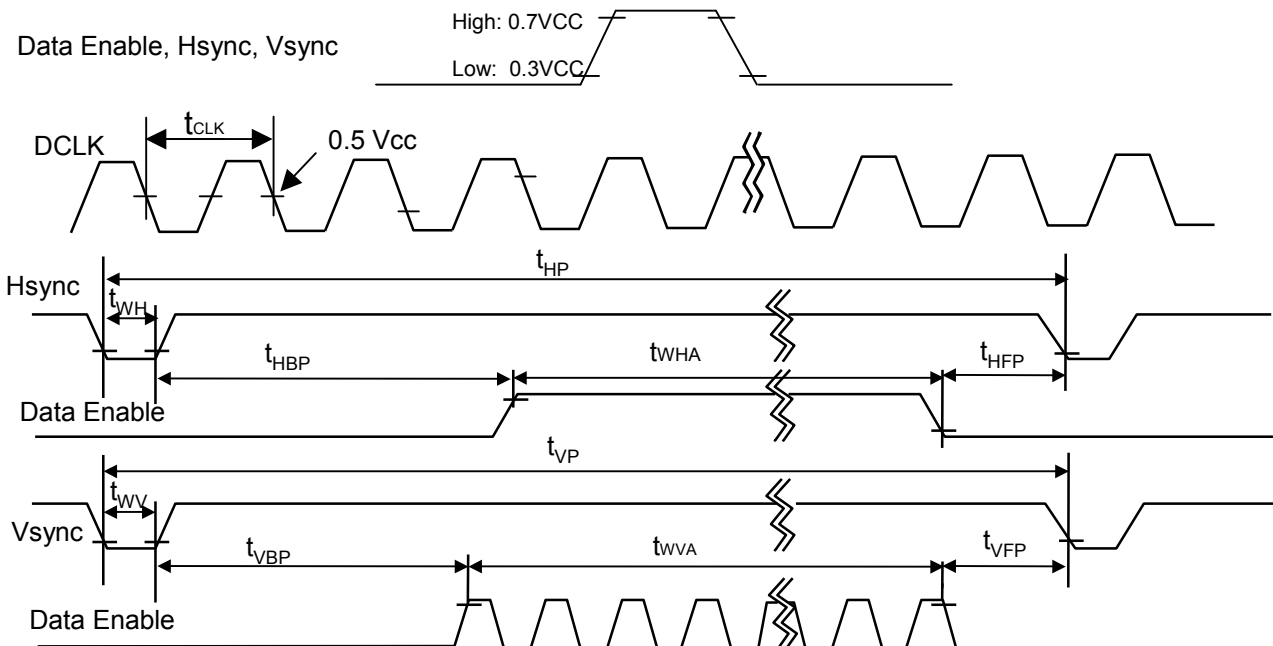

Product Specification

3-5. Color Input Data Reference

The brightness of each primary color (red, green and blue) is based on the 6-bit gray scale data input for the color ; the higher the binary input, the brighter the color. The table below provides a reference for color versus data input.

Table 7. COLOR DATA REFERENCE

| Color | | Input Color Data | | | | | | | | | | | | | | | | | |
|-------------|------------|------------------|----|----|----|-----|----|-------|----|----|----|-----|----|------|----|-----|----|----|----|
| | | RED | | | | | | GREEN | | | | | | BLUE | | | | | |
| | | MSB | | | | LSB | | MSB | | | | LSB | | MSB | | LSB | | | |
| | | R5 | R4 | R3 | R2 | R1 | R0 | G5 | G4 | G3 | G2 | G1 | G0 | B5 | B4 | B3 | B2 | B1 | B0 |
| Basic Color | Black | 0 | 0 | 0 | 0 | 0 | 0 | 0 | 0 | 0 | 0 | 0 | 0 | 0 | 0 | 0 | 0 | 0 | 0 |
| | Red | 1 | 1 | 1 | 1 | 1 | 1 | 0 | 0 | 0 | 0 | 0 | 0 | 0 | 0 | 0 | 0 | 0 | 0 |
| | Green | 0 | 0 | 0 | 0 | 0 | 0 | 1 | 1 | 1 | 1 | 1 | 1 | 0 | 0 | 0 | 0 | 0 | 0 |
| | Blue | 0 | 0 | 0 | 0 | 0 | 0 | 0 | 0 | 0 | 0 | 0 | 0 | 1 | 1 | 1 | 1 | 1 | 1 |
| | Cyan | 0 | 0 | 0 | 0 | 0 | 0 | 1 | 1 | 1 | 1 | 1 | 1 | 1 | 1 | 1 | 1 | 1 | 1 |
| | Magenta | 1 | 1 | 1 | 1 | 1 | 1 | 0 | 0 | 0 | 0 | 0 | 0 | 1 | 1 | 1 | 1 | 1 | 1 |
| | Yellow | 1 | 1 | 1 | 1 | 1 | 1 | 1 | 1 | 1 | 1 | 1 | 1 | 0 | 0 | 0 | 0 | 0 | 0 |
| | White | 1 | 1 | 1 | 1 | 1 | 1 | 1 | 1 | 1 | 1 | 1 | 1 | 1 | 1 | 1 | 1 | 1 | 1 |
| RED | RED (00) | 0 | 0 | 0 | 0 | 0 | 0 | 0 | 0 | 0 | 0 | 0 | 0 | 0 | 0 | 0 | 0 | 0 | 0 |
| | RED (01) | 0 | 0 | 0 | 0 | 0 | 1 | 0 | 0 | 0 | 0 | 0 | 0 | 0 | 0 | 0 | 0 | 0 | 0 |
| | ... | ... | | | | | | ... | | | | | | ... | | | | | |
| | RED (62) | 1 | 1 | 1 | 1 | 1 | 0 | 0 | 0 | 0 | 0 | 0 | 0 | 0 | 0 | 0 | 0 | 0 | 0 |
| | RED (63) | 1 | 1 | 1 | 1 | 1 | 1 | 0 | 0 | 0 | 0 | 0 | 0 | 0 | 0 | 0 | 0 | 0 | 0 |
| GREEN | GREEN (00) | 0 | 0 | 0 | 0 | 0 | 0 | 0 | 0 | 0 | 0 | 0 | 0 | 0 | 0 | 0 | 0 | 0 | 0 |
| | GREEN (01) | 0 | 0 | 0 | 0 | 0 | 0 | 0 | 0 | 0 | 0 | 0 | 1 | 0 | 0 | 0 | 0 | 0 | 0 |
| | ... | ... | | | | | | ... | | | | | | ... | | | | | |
| | GREEN (62) | 0 | 0 | 0 | 0 | 0 | 0 | 1 | 1 | 1 | 1 | 1 | 0 | 0 | 0 | 0 | 0 | 0 | 0 |
| | GREEN (63) | 0 | 0 | 0 | 0 | 0 | 0 | 1 | 1 | 1 | 1 | 1 | 1 | 0 | 0 | 0 | 0 | 0 | 0 |
| BLUE | BLUE (00) | 0 | 0 | 0 | 0 | 0 | 0 | 0 | 0 | 0 | 0 | 0 | 0 | 0 | 0 | 0 | 0 | 0 | 0 |
| | BLUE (01) | 0 | 0 | 0 | 0 | 0 | 0 | 0 | 0 | 0 | 0 | 0 | 0 | 0 | 0 | 0 | 0 | 0 | 1 |
| | ... | ... | | | | | | ... | | | | | | ... | | | | | |
| | BLUE (62) | 0 | 0 | 0 | 0 | 0 | 0 | 0 | 0 | 0 | 0 | 0 | 0 | 1 | 1 | 1 | 1 | 1 | 0 |
| | BLUE (63) | 0 | 0 | 0 | 0 | 0 | 0 | 0 | 0 | 0 | 0 | 0 | 0 | 1 | 1 | 1 | 1 | 1 | 1 |

Product Specification

3-6. Power Sequence

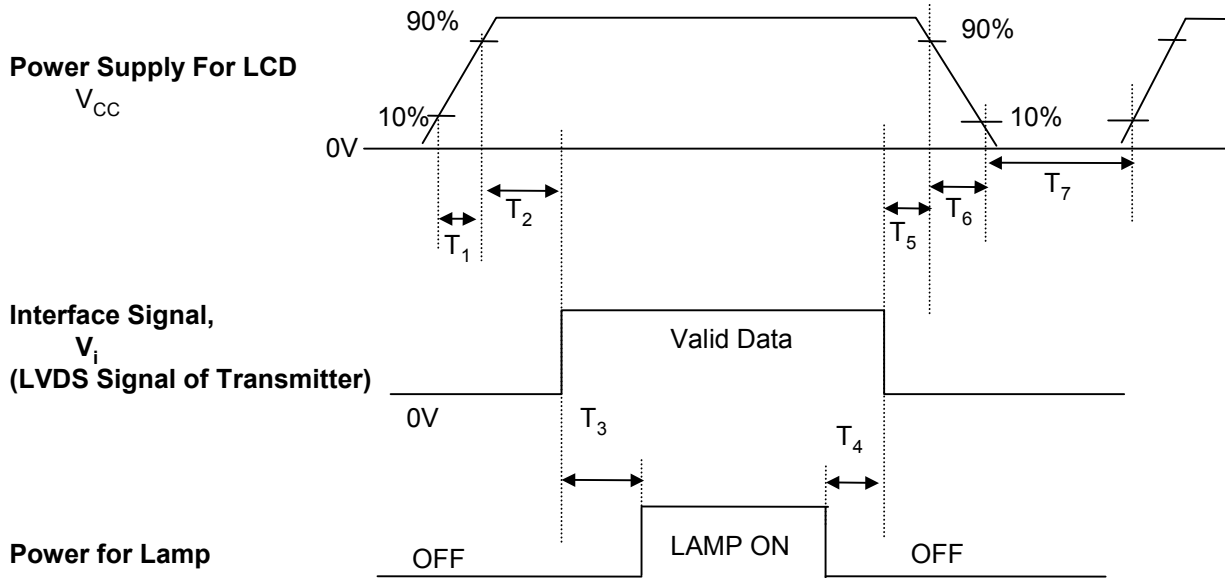

Table 8. POWER SEQUENCE TABLE

| Parameter | Value | | | Units |
|-----------|-------|------|------|-------|
| | Min. | Typ. | Max. | |
| T_1 | - | - | 10 | (ms) |
| T_2 | 0 | - | 50 | (ms) |
| T_3 | 200 | - | - | (ms) |
| T_4 | 200 | - | - | (ms) |
| T_5 | 0 | - | 50 | (ms) |
| T_6 | 0 | - | 10 | (ms) |
| T_7 | 200 | - | - | (ms) |

Note)

1. Please avoid floating state of interface signal at invalid period.
2. When the interface signal is invalid, be sure to pull down the power supply for LCD VCC to 0V.
3. Lamp power must be turn on after power supply for LCD and interface signal are valid.

Product Specification

4. Optical Specification

Optical characteristics are determined after the unit has been 'ON' and stable for approximately 30 minutes in a dark environment at 25°C. The values specified are at an approximate distance 50cm from the LCD surface at a viewing angle of Φ and Θ equal to 0°.

FIG. 1 presents additional information concerning the measurement equipment and method.

FIG. 1 Optical Characteristic Measurement Equipment and Method

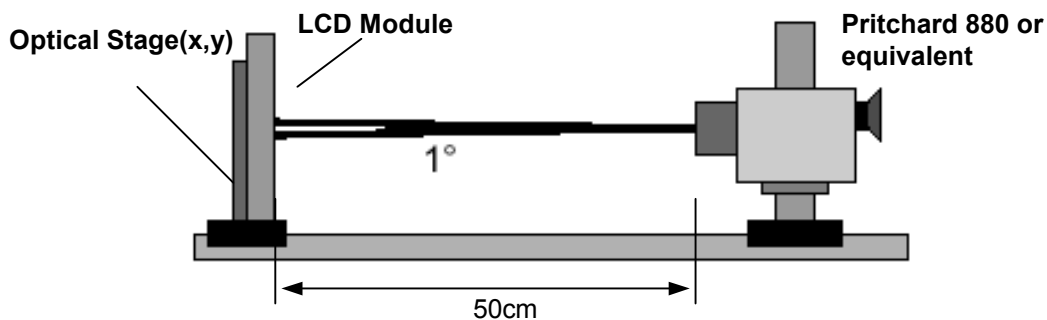

Table 9. OPTICAL CHARACTERISTICS

Ta=25°C, VCC=3.3V, fv=60Hz, f_{CLK}= 48.1MHz, Iout = 6.5mA

| Parameter | Symbol | Values | | | Units | Notes |
|-----------------------------------|--------------------------------|--------|-------|-------|-------------------|-------|
| | | Min | Typ | Max | | |
| Contrast Ratio | CR | 350 | - | - | | 1 |
| Surface Luminance, white | L _{WH} | 170 | 200 | - | cd/m ² | 2 |
| Luminance Variation | δ_{WHITE} | - | - | 2.0 | | 2 |
| Response Time | | | | | | 3 |
| Rise Time+Decay Time | T _R +T _D | - | 25 | 40 | ms | |
| Color Coordinates | | | | | | ±0.03 |
| RED | RX | 0.562 | 0.592 | 0.622 | | |
| | RY | 0.314 | 0.344 | 0.374 | | |
| GREEN | GX | 0.290 | 0.320 | 0.350 | | |
| | GY | 0.523 | 0.553 | 0.583 | | |
| BLUE | BX | 0.130 | 0.160 | 0.190 | | |
| | BY | 0.114 | 0.144 | 0.174 | | |
| WHITE | WX | 0.283 | 0.313 | 0.343 | | |
| | WY | 0.299 | 0.329 | 0.359 | | |
| Viewing Angle | | | | | | 5 |
| x axis, right($\Phi=0^\circ$) | Θ_r | 45 | - | - | degree | |
| x axis, left ($\Phi=180^\circ$) | Θ_l | 45 | - | - | degree | |
| y axis, up ($\Phi=90^\circ$) | Θ_u | 15 | - | - | degree | |
| y axis, down ($\Phi=270^\circ$) | Θ_d | 35 | - | - | degree | |
| Gray Scale | | | | | | 6 |

Product Specification

Note)

1. Contrast Ratio(CR) is defined mathematically as

$$\text{Contrast Ratio} = \frac{\text{Surface Luminance with all white pixels}}{\text{Surface Luminance with all black pixels}}$$

2. Surface luminance is the 5point (1~5)average across the LCD surface 50cm from the surface with all pixels displaying white (6.5mA). For more information see FIG 2.

$$L_{WH} = \text{Average}(L_1, L_2, \dots L_5)$$

3. Luminance uniformity is measured for 13 point For more information see FIG 2.

$$\delta \text{ WHITE} = \text{Maximum}(LN1, LN2, \dots LN13) \div \text{Minimum}(LN1, LN2, \dots LN13)$$

4. Response time is the time required for the display to transition from white to black (rise time, Tr_R) and from black to white(Decay Time, Tr_D). For additional information see FIG 3.

5. Viewing angle is the angle at which the contrast ratio is greater than 10. The angles are determined for the horizontal or x axis and the vertical or y axis with respect to the z axis which is normal to the LCD surface. For more information see FIG 4.

6. Gray scale specification

* $f_V=60\text{Hz}$

| Gray Level | Luminance [%] (Typ) |
|------------|---------------------|
| L0 | 0.2 |
| L7 | 0.96 |
| L15 | 5.3 |
| L23 | 12.9 |
| L31 | 23.1 |
| L39 | 36.0 |
| L47 | 52.4 |
| L55 | 74.9 |
| L63 | 100 |

FIG. 2 Luminance

<measuring point for surface luminance & measuring point for luminance variation>

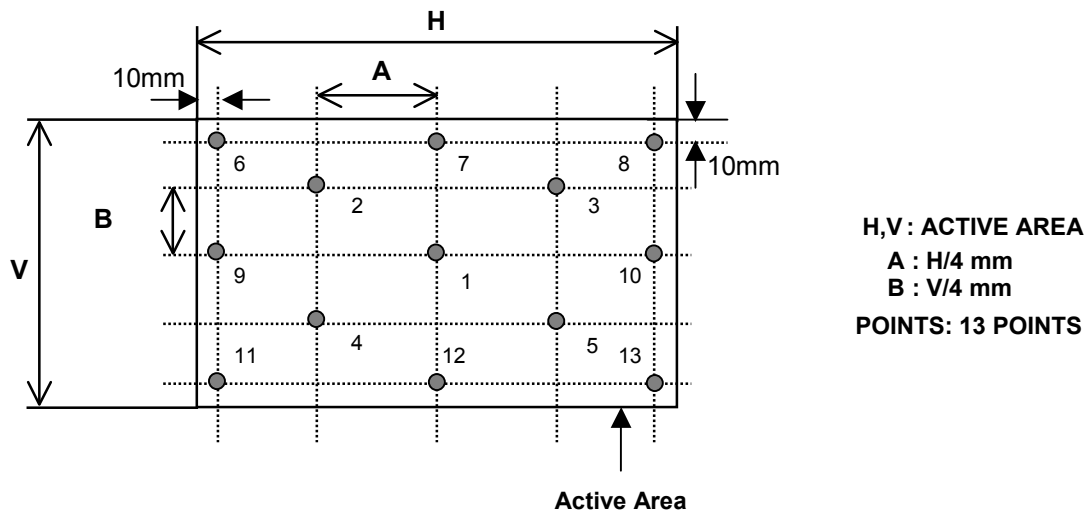

FIG. 3 Response Time

The response time is defined as the following figure and shall be measured by switching the input signal for "black" and "white".

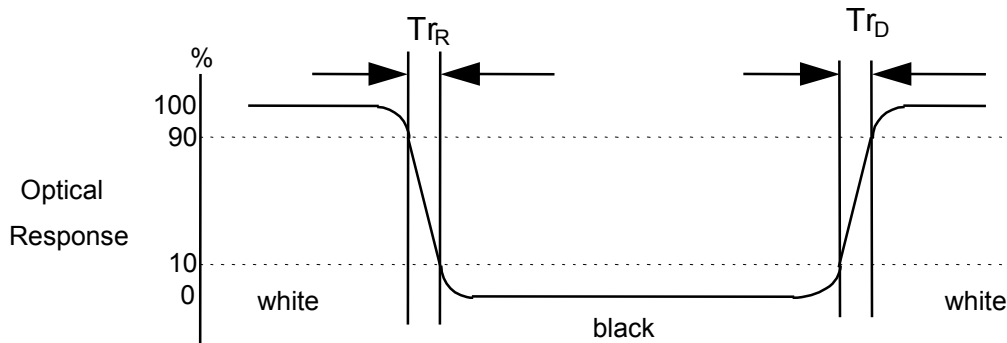
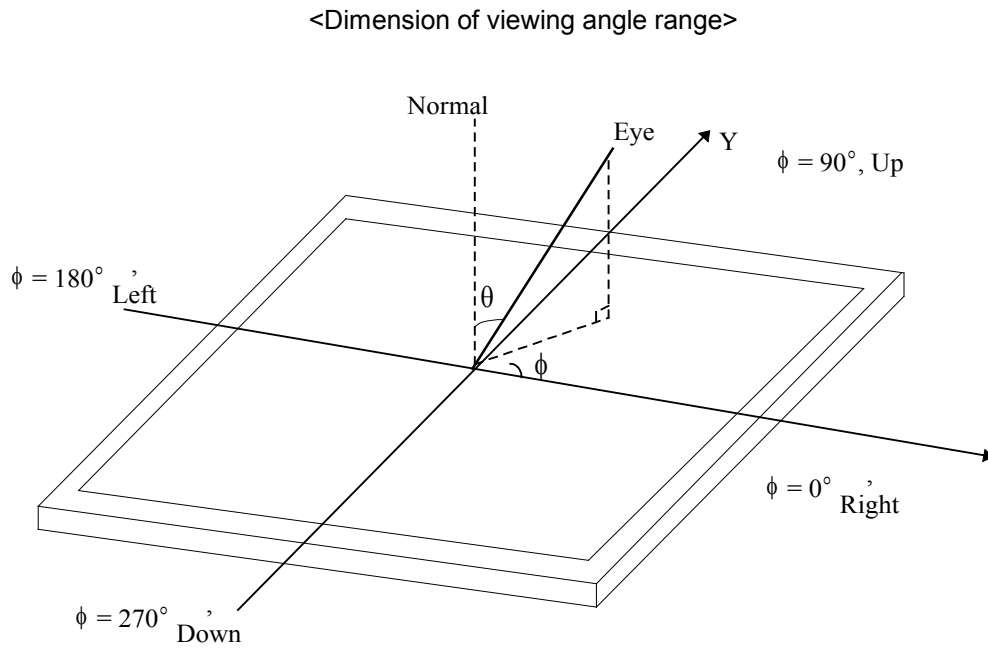

FIG. 4 Viewing angle



Product Specification

5. Mechanical Characteristics

The contents provide general mechanical characteristics for the model LP171WP4. In addition the figures in the next page are detailed mechanical drawing of the LCD.

| | | |
|---------------------|--|---------------|
| Outline Dimension | Horizontal | 382.2 ± 0.5mm |
| | Vertical | 244.5 ± 0.5mm |
| | Depth (Max) | 6.5mm |
| Bezel Area | Horizontal | 370.6 ± 0.5mm |
| | Vertical | 232.9 ± 0.5mm |
| Active Display Area | Horizontal | 367.2 mm |
| | Vertical | 229.5 mm |
| Weight | 670g (Typ.) 685g (Max.) | |
| Surface Treatment | Glare reflective treatment of the front Polarizer 2H | |

Product Specification

<FRONT VIEW>

Note) Unit:[mm], General tolerance: $\pm 0.5\text{mm}$

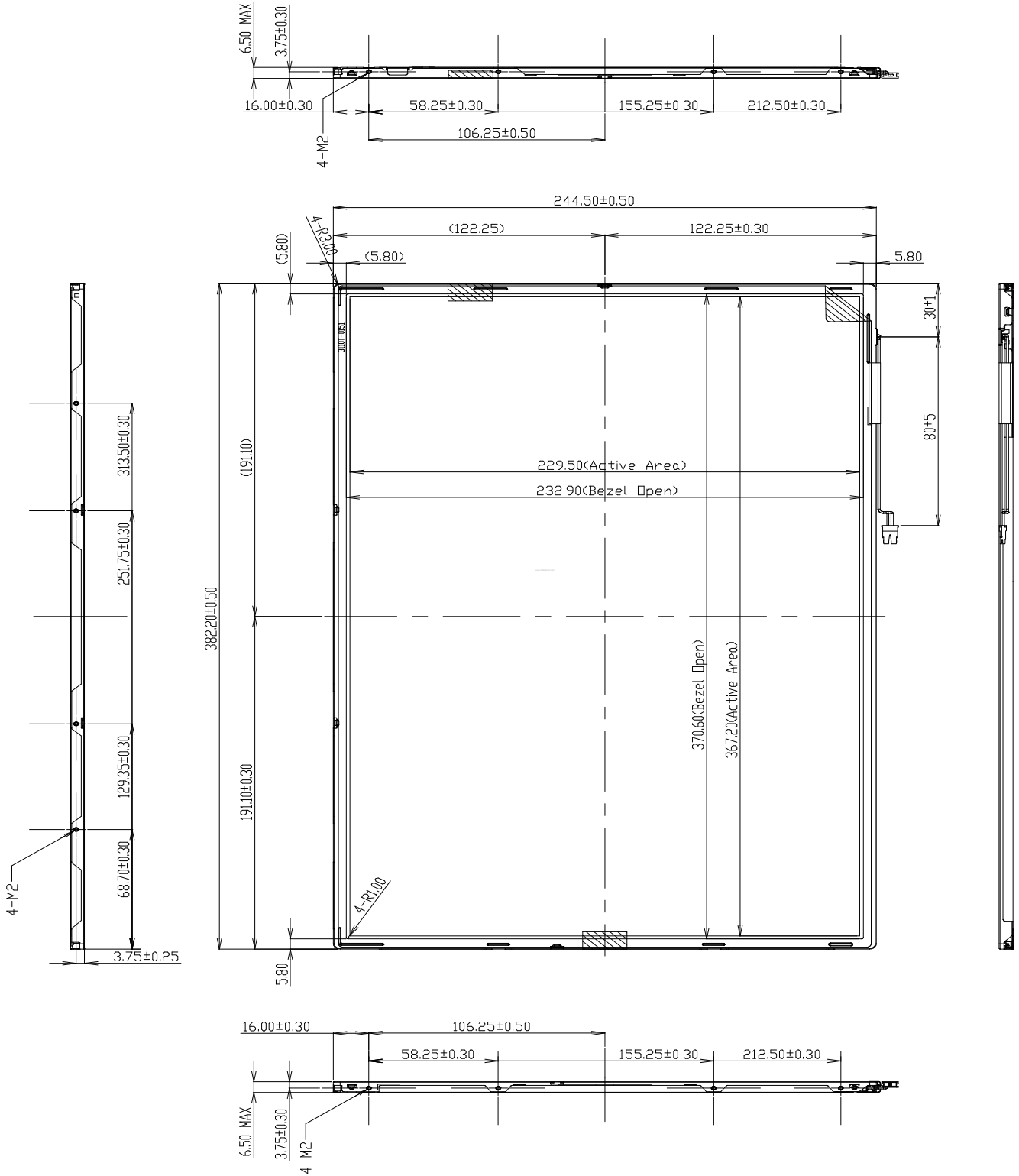

Product Specification

<REAR VIEW>

Note) Unit:[mm], General tolerance: $\pm 0.5\text{mm}$

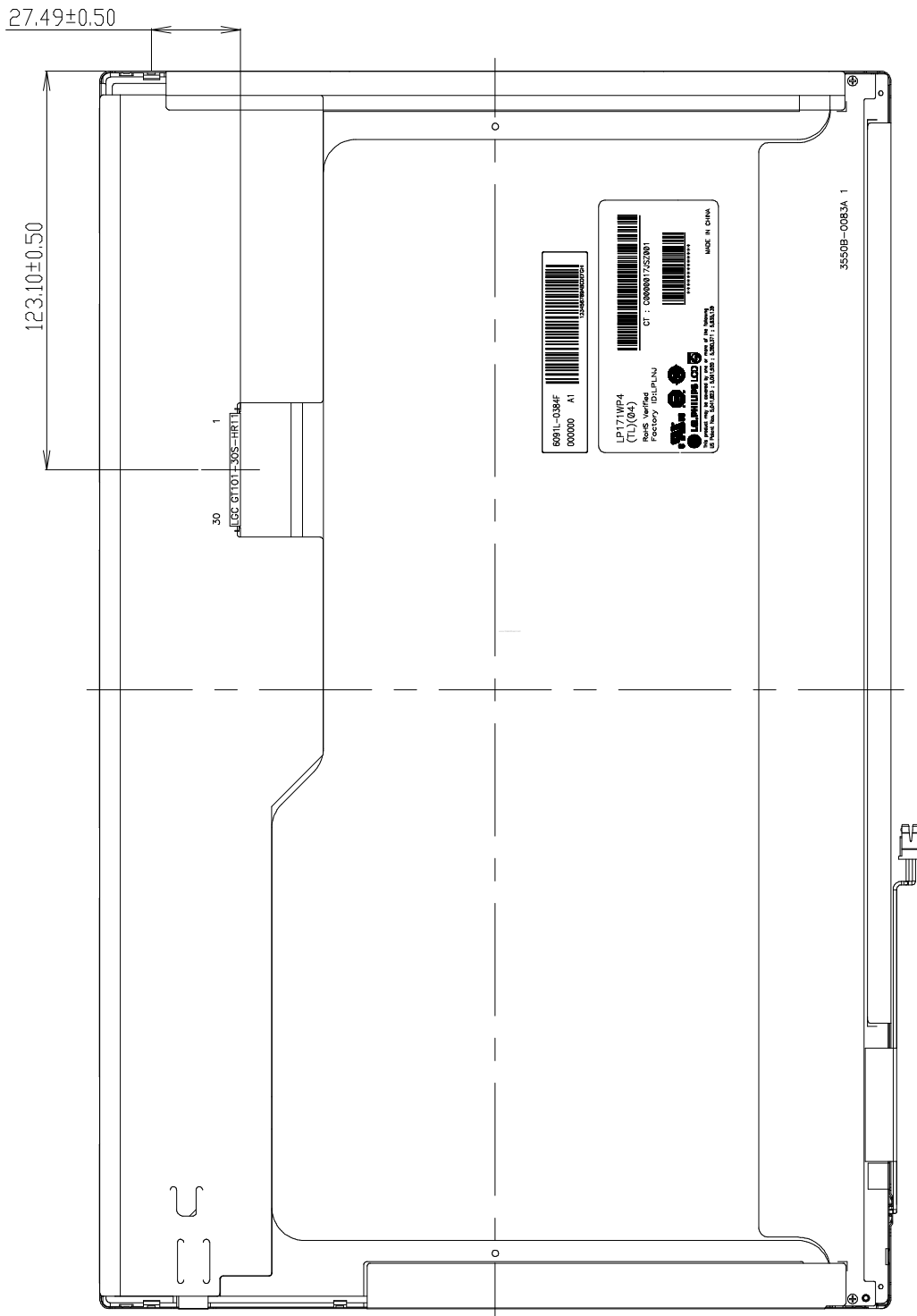

Product Specification

[DETAIL DESCRIPTION OF SIDE MOUNTING SCREW]

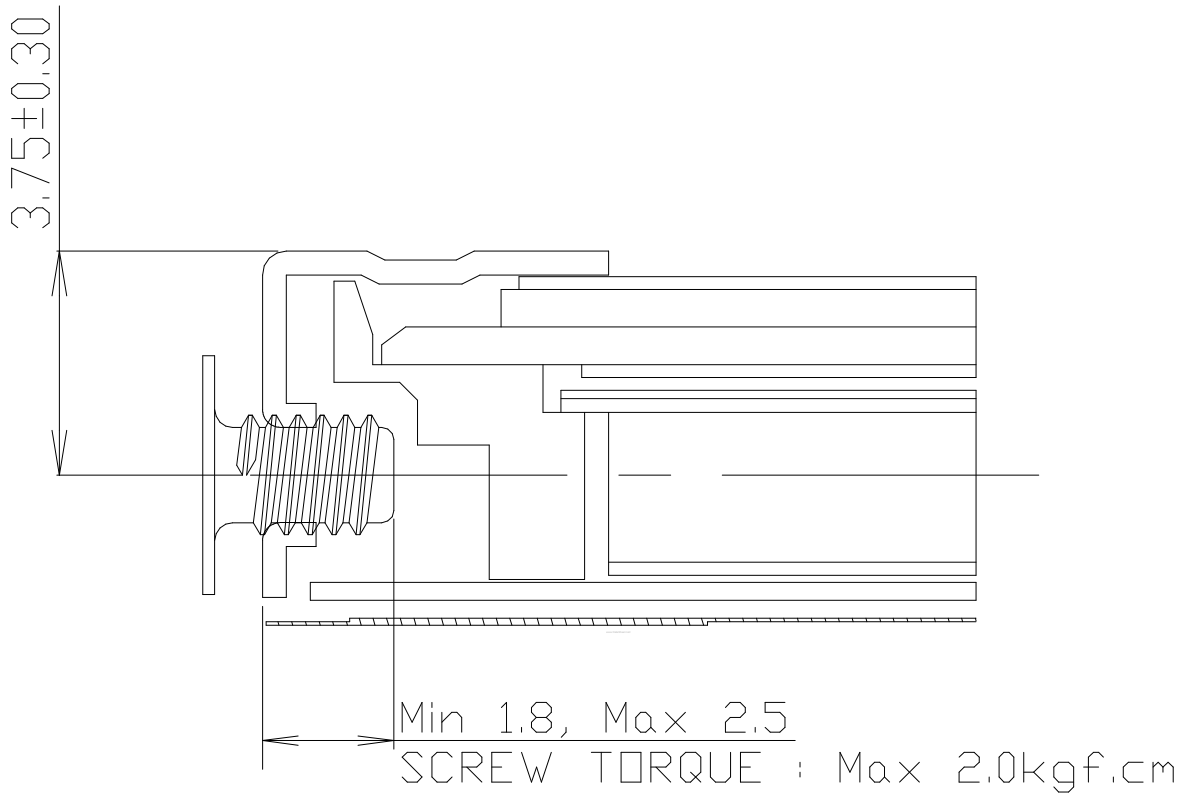

Note) Unit:[mm], General tolerance: ± 0.5mm

Product Specification

6. Reliability

Environment test condition

| No. | Test Item | Conditions |
|-----|---|--|
| 1 | High temperature storage test | Ta= 60°C, 240h |
| 2 | Low temperature storage test | Ta= -20°C, 240h |
| 3 | High temperature operation test | Ta= 50°C, 50%RH, 240h |
| 4 | Low temperature operation test | Ta= 0°C, 240h |
| 5 | Vibration test (non-operating) | Sine wave, 5 ~ 150Hz, 1.5G, 0.37oct/min 3 axis, 30min/axis |
| 6 | Shock test (non-operating) | Half sine wave, 180G, 2ms one shock of each six faces(I.e. run 180G 2ms for all six faces) |
| 7 | Altitude operating storage / shipment | 0 ~ 10,000 feet (3,048m) 24Hr 0 ~ 40,000 feet (12,192m) 24Hr |

{ Result Evaluation Criteria }

There should be no change which might affect the practical display function when the display quality test is conducted under normal operating condition.

7. International Standards

7-1. Safety

- a) UL 60950-1:2003, First Edition, Underwriters Laboratories, Inc., Standard for Safety of Information Technology Equipment.
- b) CAN/CSA C22.2, No. 60950-1-03 1st Ed. April 1, 2003, Canadian Standards Association, Standard for Safety of Information Technology Equipment.
- c) EN 60950-1:2001, First Edition, European Committee for Electrotechnical Standardization(CENELEC) European Standard for Safety of Information Technology Equipment.

7-2. EMC

- a) ANSI C63.4 "Methods of Measurement of Radio-Noise Emissions from Low-Voltage Electrical and Electrical Equipment in the Range of 9kHz to 40GHz. "American National Standards Institute(ANSI), 1992
- b) C.I.S.P.R. "Limits and Methods of Measurement of Radio Interface Characteristics of Information Technology Equipment." International Special Committee on Radio Interference.
- c) EN 55022 "Limits and Methods of Measurement of Radio Interface Characteristics of Information Technology Equipment." European Committee for Electrotechnical Standardization.(CENELEC), 1998 (Including A1: 2000)

Product Specification

8. Packing

8-1. Designation of Lot Mark

a) Lot Mark

| | | | | | | | | | | | | |
|---|---|---|---|---|---|---|---|---|---|---|---|---|
| A | B | C | D | E | F | G | H | I | J | K | L | M |
|---|---|---|---|---|---|---|---|---|---|---|---|---|

A,B,C : SIZE(INCH)
E : MONTH

D : YEAR
F ~ M : SERIAL NO.

Note

1. YEAR

| | | | | | | | | | | |
|------|------|------|------|------|------|------|------|------|------|------|
| Year | 2001 | 2002 | 2003 | 2004 | 2005 | 2006 | 2007 | 2008 | 2009 | 2010 |
| Mark | 1 | 2 | 3 | 4 | 5 | 6 | 7 | 8 | 9 | 0 |

2. MONTH

| | | | | | | | | | | | | |
|-------|-----|-----|-----|-----|-----|-----|-----|-----|-----|-----|-----|-----|
| Month | Jan | Feb | Mar | Apr | May | Jun | Jul | Aug | Sep | Oct | Nov | Dec |
| Mark | 1 | 2 | 3 | 4 | 5 | 6 | 7 | 8 | 9 | A | B | C |

b) Location of Lot Mark

Serial No. is printed on the label. The label is attached to the backside of the LCD module.
This is subject to change without prior notice.

8-2. Packing Form

a) Package quantity in one box : 20 pcs

b) Box Size : 482mm × 371mm × 325mm

9. PRECAUTIONS

Please pay attention to the followings when you use this TFT LCD module.

9-1. MOUNTING PRECAUTIONS

- (1) You must mount a module using holes arranged in four corners or four sides.
- (2) You should consider the mounting structure so that uneven force (ex. Twisted stress) is not applied to the module. And the case on which a module is mounted should have sufficient strength so that external force is not transmitted directly to the module.
- (3) Please attach the surface transparent protective plate to the surface in order to protect the polarizer. Transparent protective plate should have sufficient strength in order to resist external force.
- (4) You should adopt radiation structure to satisfy the temperature specification.
- (5) Acetic acid type and chlorine type materials for the cover case are not desirable because the former generates corrosive gas of attacking the polarizer at high temperature and the latter causes circuit break by electro-chemical reaction.
- (6) Do not touch, push or rub the exposed polarizers with glass, tweezers or anything harder than HB pencil lead. And please do not rub with dust clothes with chemical treatment. Do not touch the surface of polarizer for bare hand or greasy cloth. (Some cosmetics are detrimental to the polarizer.)
- (7) When the surface becomes dusty, please wipe gently with absorbent cotton or other soft materials like chamois soaks with petroleum benzene. Normal-hexane is recommended for cleaning the adhesives used to attach front / rear polarizers. Do not use acetone, toluene and alcohol because they cause chemical damage to the polarizer.
- (8) Wipe off saliva or water drops as soon as possible. Their long time contact with polarizer causes deformations and color fading.
- (9) Do not open the case because inside circuits do not have sufficient strength.

9-2. OPERATING PRECAUTIONS

- (1) The spike noise causes the mis-operation of circuits. It should be lower than following voltage :
 $V = \pm 200\text{mV}$ (Over and under shoot voltage)
- (2) Response time depends on the temperature. (In lower temperature, it becomes longer.)
- (3) Brightness depends on the temperature. (In lower temperature, it becomes lower.)
And in lower temperature, response time (required time that brightness is stable after turned on) becomes longer.
- (4) Be careful for condensation at sudden temperature change. Condensation makes damage to polarizer or electrical contacted parts. And after fading condensation, smear or spot will occur.
- (5) When fixed patterns are displayed for a long time, remnant image is likely to occur.
- (6) Module has high frequency circuits. Sufficient suppression to the electromagnetic interference shall be done by system manufacturers. Grounding and shielding methods may be important to minimize the interference.

9-3. ELECTROSTATIC DISCHARGE CONTROL

Since a module is composed of electronic circuits, it is not strong to electrostatic discharge. Make certain that treatment persons are connected to ground through wrist band etc. And don't touch interface pin directly.

9-4. PRECAUTIONS FOR STRONG LIGHT EXPOSURE

Strong light exposure causes degradation of polarizer and color filter.

9-5. STORAGE

When storing modules as spares for a long time, the following precautions are necessary.

- (1) Store them in a dark place. Do not expose the module to sunlight or fluorescent light. Keep the temperature between 5°C and 35°C at normal humidity.
- (2) The polarizer surface should not come in contact with any other object.
It is recommended that they be stored in the container in which they were shipped.

9-6. HANDLING PRECAUTIONS FOR PROTECTION FILM

- (1) When the protection film is peeled off, static electricity is generated between the film and polarizer. This should be peeled off slowly and carefully by people who are electrically grounded and with well ion-blown equipment or in such a condition, etc.
- (2) The protection film is attached to the polarizer with a small amount of glue. If some stress is applied to rub the protection film against the polarizer during the time you peel off the film, the glue is apt to remain on the polarizer.
Please carefully peel off the protection film without rubbing it against the polarizer.
- (3) When the module with protection film attached is stored for a long time, sometimes there remains a very small amount of glue still on the polarizer after the protection film is peeled off.
- (4) You can remove the glue easily. When the glue remains on the polarizer surface or its vestige is recognized, please wipe them off with absorbent cotton waste or other soft material like chamois soaked with normal-hexane.

Product Specification

APPENDIX A. Enhanced Extended Display Identification Data (EEDID™) 1/3
LP171WP4-TL04 E-EDID DATA (ver0.0)

2007-02-12

| Byte# (decimal) | Byte# (HEX) | Field Name and Comments | Value (HEX) | Value (binary) | |
|--------------------|----------------|--|----------------|-------------------|---------------------------|
| 0 | 00 | Header | 0 0 | 0000 0000 | Header |
| 1 | 01 | | F F | 1111 1111 | |
| 2 | 02 | | F F | 1111 1111 | |
| 3 | 03 | | F F | 1111 1111 | |
| 4 | 04 | | F F | 1111 1111 | |
| 5 | 05 | | F F | 1111 1111 | |
| 6 | 06 | | F F | 1111 1111 | |
| 7 | 07 | | 0 0 | 0000 0000 | Vendor/ Product ID |
| 8 | 08 | EISA manufacturer code(3 Character ID) = LPL | 3 2 | 0011 0010 | |
| 9 | 09 | Compressed ASCII | 0 C | 0000 1100 | |
| 10 | 0A | Panel Supplier Reserved - Product code | 8 8 | 1000 1000 | |
| 11 | 0B | (Hex, LSB first) | 2 3 | 0010 0011 | |
| 12 | 0C | LCD Module Serial No. = 0 (If not used) | 0 0 | 0000 0000 | |
| 13 | 0D | LCD Module Serial No. = 0 (If not used) | 0 0 | 0000 0000 | |
| 14 | 0E | LCD Module Serial No. = 0 (If not used) | 0 0 | 0000 0000 | |
| 15 | 0F | LCD Module Serial No. = 0 (If not used) | 0 0 | 0000 0000 | EDID Version/ Revision |
| 16 | 10 | Week of Manufacture = 00 | 0 0 | 0000 0000 | |
| 17 | 11 | Year of manufacture = 2005 | 0 F | 0000 1111 | Display Parameter |
| 18 | 12 | EDID Structure version # = 1 | 0 1 | 0000 0001 | |
| 19 | 13 | EDID Revision # = 2 | 0 2 | 0000 0010 | Color Characteristic |
| 20 | 14 | Video input definition = Digital I/p,non TMDS CRGB | 8 0 | 1000 0000 | |
| 21 | 15 | Max H image size(cm) = 36.72cm (37) | 2 5 | 0010 0101 | |
| 22 | 16 | Max V image size(cm) = 22.95cm (23) | 1 7 | 0001 0111 | |
| 23 | 17 | Display gamma = 2.20 | 7 8 | 0111 1000 | |
| 24 | 18 | Feature support(DPMS) = Active off, RGB Color | 0 A | 0000 1010 | |
| 25 | 19 | Red/Green low Bits | C A | 1100 1010 | |
| 26 | 1A | Blue/White Low Bits | C 0 | 1100 0000 | |
| 27 | 1B | Red X Rx = 0.597 | 9 8 | 1001 1000 | |
| 28 | 1C | Red Y Ry = 0.348 | 5 9 | 0101 1001 | |
| 29 | 1D | Green X Gx = 0.334 | 5 5 | 0101 0101 | |
| 30 | 1E | Green Y Gy = 0.545 | 8 B | 1000 1011 | |
| 31 | 1F | Blue X Bx = 0.156 | 2 7 | 0010 0111 | |
| 32 | 20 | Blue Y By = 0.133 | 2 2 | 0010 0010 | |
| 33 | 21 | White X Wx = 0.313 | 5 0 | 0101 0000 | |
| 34 | 22 | White Y Wy = 0.329 | 5 4 | 0101 0100 | |
| 35 | 23 | Established Timing I | 0 0 | 0000 0000 | Standard Timing ID |
| 36 | 24 | Established Timing II | 0 0 | 0000 0000 | |
| 37 | 25 | Manufacturer's Timings | 0 0 | 0000 0000 | |
| 38 | 26 | Standard Timing Identification 1 was not used | 0 1 | 0000 0001 | |
| 39 | 27 | Standard Timing Identification 1 was not used | 0 1 | 0000 0001 | |
| 40 | 28 | Standard Timing Identification 2 was not used | 0 1 | 0000 0001 | |
| 41 | 29 | Standard Timing Identification 2 was not used | 0 1 | 0000 0001 | |
| 42 | 2A | Standard Timing Identification 3 was not used | 0 1 | 0000 0001 | |
| 43 | 2B | Standard Timing Identification 3 was not used | 0 1 | 0000 0001 | |
| 44 | 2C | Standard Timing Identification 4 was not used | 0 1 | 0000 0001 | |
| 45 | 2D | Standard Timing Identification 4 was not used | 0 1 | 0000 0001 | |
| 46 | 2E | Standard Timing Identification 5 was not used | 0 1 | 0000 0001 | |
| 47 | 2F | Standard Timing Identification 5 was not used | 0 1 | 0000 0001 | |
| 48 | 30 | Standard Timing Identification 6 was not used | 0 1 | 0000 0001 | |
| 49 | 31 | Standard Timing Identification 6 was not used | 0 1 | 0000 0001 | |
| 50 | 32 | Standard Timing Identification 7 was not used | 0 1 | 0000 0001 | |
| 51 | 33 | Standard Timing Identification 7 was not used | 0 1 | 0000 0001 | |
| 52 | 34 | Standard Timing Identification 8 was not used | 0 1 | 0000 0001 | |
| 53 | 35 | Standard Timing Identification 8 was not used | 0 1 | 0000 0001 | |

Product Specification

APPENDIX A. Enhanced Extended Display Identification Data (EEDID™) 2/3

| Byte# (decimal) | Byte# (HEX) | Field Name and Comments | Value (HEX) | Value (binary) | |
|--------------------|----------------|---|----------------|-------------------|---|
| 54 | 36 | 1440 X 900 @60Hz mode : pixel clock = 96.21MHz | 9 5 | 1001 0101 | Detailed Timing Description #1 |
| 55 | 37 | (Stored LSB first) | 2 5 | 0010 0101 | |
| 56 | 38 | Horizontal Active = 1440 pixels | A 0 | 1010 0000 | |
| 57 | 39 | Horizontal Blanking = 320 pixels | 4 0 | 0100 0000 | |
| 58 | 3A | Horizontal Active : Horizontal Blanking = 1440 : 320 | 5 1 | 0101 0001 | |
| 59 | 3B | Vertical Avtive = 900 lines | 8 4 | 1000 0100 | |
| 60 | 3C | Vertical Blanking = 12 lines | 0 C | 0000 1100 | |
| 61 | 3D | Vertical Active : Vertical Blanking = 900 : 12 | 3 0 | 0011 0000 | |
| 62 | 3E | Horizontal Sync. Offset = 64 pixels | 4 0 | 0100 0000 | |
| 63 | 3F | Horizontal Sync Pulse Width = 32 pixels | 2 0 | 0010 0000 | |
| 64 | 40 | Vertical Sync Offset = 1 lines, Sync Width = 3 lines | 1 3 | 0001 0011 | |
| 65 | 41 | Horizontal Vertical Sync Offset/Width upper 2bits = 0 | 0 0 | 0000 0000 | |
| 66 | 42 | Horizontal Image Size = 367.2mm (367) | 6 F | 0110 1111 | |
| 67 | 43 | Vertical Image Size = 229.5mm (230) | E 6 | 1110 0110 | |
| 68 | 44 | Horizontal & Vertical Image Size | 1 0 | 0001 0000 | |
| 69 | 45 | Horizontal Border = 0 | 0 0 | 0000 0000 | |
| 70 | 46 | Vertical Border = 0 | 0 0 | 0000 0000 | |
| 71 | 47 | Non-interlaced, Normal display, no stereo, Digital separate sync, H/V pol negatives | 1 9 | 0001 1001 | |
| 72 | 48 | Detailed Timing Descriptor #2 | 0 0 | 0000 0000 | Detailed Timing Description #2 |
| 73 | 49 | | 0 0 | 0000 0000 | |
| 74 | 4A | | 0 0 | 0000 0000 | |
| 75 | 4B | | 0 0 | 0000 0000 | |
| 76 | 4C | | 0 0 | 0000 0000 | |
| 77 | 4D | | 0 0 | 0000 0000 | |
| 78 | 4E | | 0 0 | 0000 0000 | |
| 79 | 4F | | 0 0 | 0000 0000 | |
| 80 | 50 | | 0 0 | 0000 0000 | |
| 81 | 51 | | 0 0 | 0000 0000 | |
| 82 | 52 | | 0 0 | 0000 0000 | |
| 83 | 53 | | 0 0 | 0000 0000 | |
| 84 | 55 | | 0 0 | 0000 0000 | |
| 85 | 55 | | 0 0 | 0000 0000 | |
| 86 | 56 | | 0 0 | 0000 0000 | |
| 87 | 57 | | 0 0 | 0000 0000 | |
| 88 | 58 | | 0 0 | 0000 0000 | |
| 89 | 59 | | 0 0 | 0000 0000 | |
| 90 | 5A | Detailed Timing Descriptor #3 | 0 0 | 0000 0000 | Detailed Timing Description #3 |
| 91 | 5B | | 0 0 | 0000 0000 | |
| 92 | 5C | | 0 0 | 0000 0000 | |
| 93 | 5D | | F E | 1111 1110 | |
| 94 | 5E | | 0 0 | 0000 0000 | |
| 95 | 5F | L | 4 C | 0100 1100 | |
| 96 | 60 | G | 4 7 | 0100 0111 | |
| 97 | 61 | P | 5 0 | 0101 0000 | |
| 98 | 62 | h | 6 8 | 0110 1000 | |
| 99 | 63 | i | 6 9 | 0110 1001 | |
| 100 | 64 | l | 6 C | 0110 1100 | |
| 101 | 65 | i | 6 9 | 0110 1001 | |
| 102 | 66 | p | 7 0 | 0111 0000 | |
| 103 | 67 | s | 7 3 | 0111 0011 | |
| 104 | 68 | L | 4 C | 0100 1100 | |
| 105 | 69 | C | 4 3 | 0100 0011 | |
| 106 | 6A | D | 4 4 | 0100 0100 | |
| 107 | 6B | LF | 0 A | 0000 1010 | |

Product Specification

APPENDIX A. Enhanced Extended Display Identification Data (EEDID™) 3/3

| Byte# (decimal) | Byte# (HEX) | Field Name and Comments | Value (HEX) | Value (binary) | |
|--------------------|----------------|-------------------------------|----------------|-------------------|---|
| 108 | 6C | Detailed Timing Descriptor #4 | 0 0 | 0000 0000 | Detailed Timing Description #4 |
| 109 | 6D | | 0 0 | 0000 0000 | |
| 110 | 6E | | 0 0 | 0000 0000 | |
| 111 | 6F | | F E | 1111 1110 | |
| 112 | 70 | | 0 0 | 0000 0000 | |
| 113 | 71 | L | 4 C | 0100 1100 | |
| 114 | 72 | P | 5 0 | 0101 0000 | |
| 115 | 73 | 1 | 3 1 | 0011 0001 | |
| 116 | 74 | 7 | 3 7 | 0011 0111 | |
| 117 | 75 | 1 | 3 1 | 0011 0001 | |
| 118 | 76 | W | 5 7 | 0101 0111 | |
| 119 | 77 | P | 5 0 | 0101 0000 | |
| 120 | 78 | 4 | 3 4 | 0011 0100 | |
| 121 | 79 | - | 2 D | 0010 1101 | |
| 122 | 7A | T | 5 4 | 0101 0100 | |
| 123 | 7B | L | 4 C | 0100 1100 | |
| 124 | 7C | 0 | 3 0 | 0011 0000 | |
| 125 | 7D | 4 | 3 4 | 0011 0100 | |
| 126 | 7E | Extension flag = 00 | 0 0 | 0000 0000 | Extension Flag |
| 127 | 7F | Checksum | 5 3 | 0101 0011 | Checksum |