

Product Specification

SPECIFICATION FOR APPROVAL

- (◆) Preliminary Specification
- () Final Specification

Title	17.3" FHD TFT LCD
-------	-------------------

Customer	
MODEL	

SUPPLIER	LG Display Co., Ltd.
*MODEL	LP173WF4
Suffix	SPF1

*When you obtain standard approval,
please use the above model name without suffix

APPROVED BY	SIGNATURE
/	_____
/	_____
/	_____

APPROVED BY	SIGNATURE
J. Y. Lee / Manager	_____
REVIEWED BY	
Y. S. Ha / Manager	_____
PREPARED BY	
S. U. Kim / Engineer	_____

Please return 1 copy for your confirmation with your signature and comments.

**Products Engineering Dept.
LG Display Co., Ltd**

Product Specification

Contents

No	ITEM	Page
	COVER	1
	CONTENTS	2
	RECORD OF REVISIONS	3
1	GENERAL DESCRIPTION	4
2	ABSOLUTE MAXIMUM RATINGS	5
3	ELECTRICAL SPECIFICATIONS	
3-1	ELECTRICAL CHARACTERISTICS	6
3-2	INTERFACE CONNECTION	8
3-3	eDP SIGNAL TIMING SPECIFICATIONS	9
3-4	SIGNAL TIMING SPECIFICATIONS	10
3-5	SIGNAL TIMING WAVEFORMS	10
3-6	COLOR INPUT DATA REFERENCE	11
3-7	POWER SEQUENCE	12
4	OPTICAL SPECIFICATIONS	13
5	MECHANICAL CHARACTERISTICS	16~18
A	APPENDIX. LGD PROPOSAL FOR SYSTEM COVER DESIGN	19~23
6	RELIABILITY	24
7	INTERNATIONAL STANDARDS	25
7-1	SAFETY	25
7-2	EMC	25
8	PACKING	26
8-1	DESIGNATION OF LOT MARK	26
8-2	PACKING FORM	26
8-3	CT Code	26
9	PRECAUTIONS	27
A	APPENDIX. Enhanced Extended Display Identification Data	29~31

Product Specification

RECORD OF REVISIONS

Revision No	Revision Date	Page	Description	EDID ver
0.0	Oct. 15. 2013	All	First Draft (Preliminary Specification)	

Product Specification

1. General Description

The LP173WF4 is a Color Active Matrix Liquid Crystal Display with an integral LED backlight system. The matrix employs a-Si Thin Film Transistor as the active element. It is a transmissive type display operating in the normally white mode. This TFT-LCD has 12.5inches diagonally measured active display area with HD resolution(1366 horizontal by 768 vertical pixel array). Each pixel is divided into Red, Green and Blue sub-pixels or dots which are arranged in vertical stripes. Gray scale or the brightness of the sub-pixel color is determined with a 6-bit gray scale signal for each dot, thus, presenting a palette of more than 262,144 colors.

The LP173WF4 has been designed to apply the interface method that enables low power, high speed, low EMI.

The LP173WF4 is intended to support applications where thin thickness, low power are critical factors and graphic displays are important. In combination with the vertical arrangement of the sub-pixels, the LP173WF4 characteristics provide an excellent flat display for office automation products such as Notebook PC.

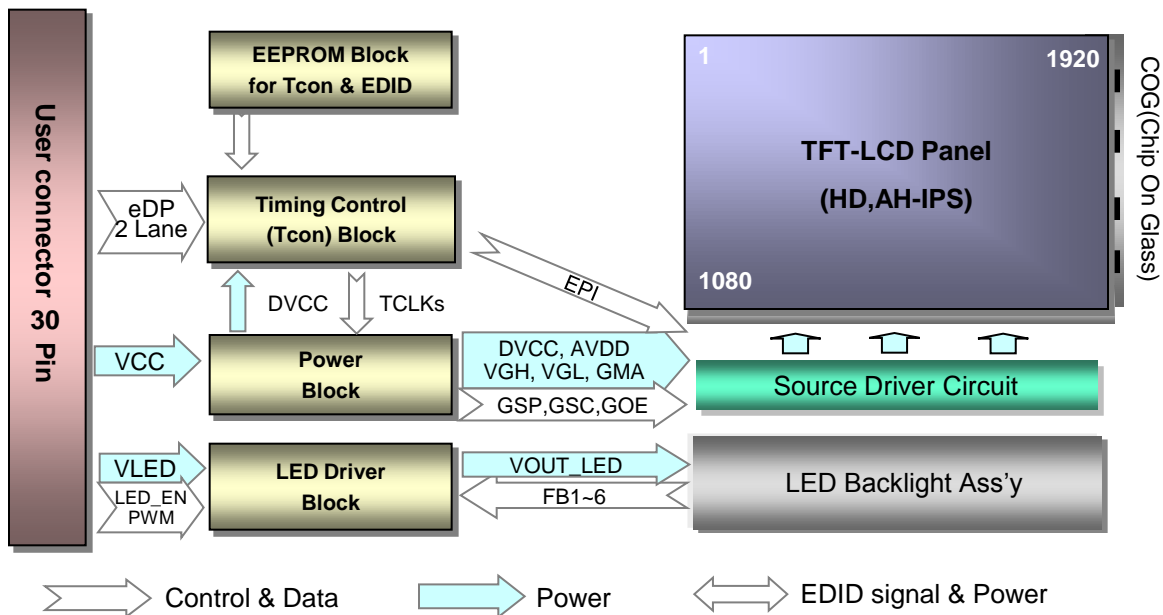

General Features

Active Screen Size	17.3 inches diagonal
Outline Dimension	399.5(H) × 241.95(V) × 4.0(D,Max.) [mm] (w/o PCB)
Pixel Pitch	0.198.9mm × 0.198.9 mm
Pixel Format	1920 horiz. By 1080 vert. Pixels RGB strip arrangement
Color Depth	6-bit, 262,144 colors
Luminance, White	300 cd/m ² (Typ.5 point)
Power Consumption	Total 6.8 (Typ.) Logic :1.1W@ Mosaic, B/L : 5.7W@ VLED 12V
Weight	550g (Max.)
Display Operating Mode	AH-IPS, Normally Black
Surface Treatment	Anti Glare treatment of the front polarizer
RoHS Compliance	Yes
BFR / PVC / As Free	Yes for all

2. Absolute Maximum Ratings

The following are maximum values which, if exceeded, may cause faulty operation or damage to the unit.

Table 1. ABSOLUTE MAXIMUM RATINGS

Parameter	Symbol	Values		Units	Notes
		Min	Max		
Power Input Voltage	VCC	-0.3	4.0	Vdc	at 25 ± 5°C
Operating Temperature	TOP	0	50	°C	1
Storage Temperature	HST	-20	60	°C	1
Operating Ambient Humidity	HOP	10	90	%RH	1
Storage Humidity	HST	10	90	%RH	1

Note : 1. Temperature and relative humidity range are shown in the figure below.

Wet bulb temperature should be 39°C Max, and no condensation of water.

Note : 2. Storage Condition is guaranteed under packing condition.

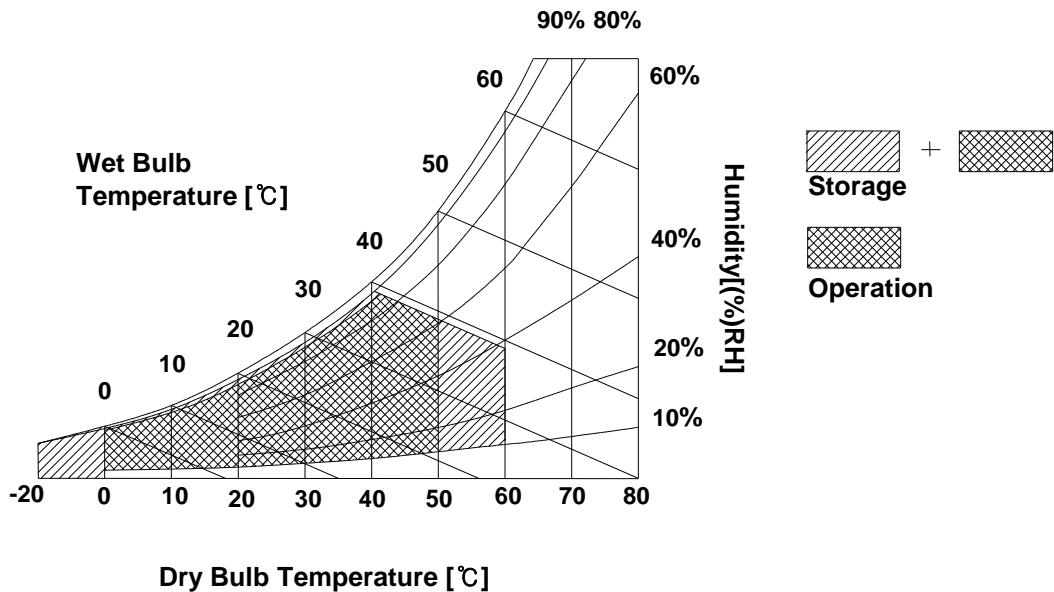

Product Specification

3. Electrical Specifications

3-1. Electrical Characteristics

The LP173WF4 requires two power inputs. One is employed to power the LCD electronics and to drive the TFT array and liquid crystal. The second input which powers the LED BL.

Table 2. ELECTRICAL CHARACTERISTICS

Parameter	Symbol	Values			Unit	Notes
		Min	Typ	Max		
LOGIC :						
Power Supply Input Voltage	V _{CC}	3.0	3.3	3.6	V	1
Power Supply Input Current	I _{CC}	-	334	394	mA	2
Power Consumption	P _{CC}	-	1.1	1.3	W	3
Power Supply Inrush Current	I _{CC_P}	-		1500	mA	4
eDP Impedance	Z _{LVDs}	90	100	110	Ω	4
BACKLIGHT : (with LED Driver)						
LED Power Input Voltage	V _{LED}	5.5	12.0	21.0	V	6
LED Power Input Current	I _{LED}	-	475	500	mA	7
LED Power Consumption	P _{LED}	-	5.7	6.0	W	7
LED Power Inrush Current	I _{LED_P}	-		2000	mA	8
PWM Duty Ratio		5	-	100	%	9
PWM Jitter	-	0	-	0.2	%	10
PWM Impedance	Z _{PWM}	20	40	60	kΩ	
PWM Frequency	F _{PWM}	200	-	1000	Hz	11
PWM High Level Voltage	V _{PWM_H}	2.2	-	5.3	V	
PWM Low Level Voltage	V _{PWM_L}	0	-	0.3	V	
LED_EN Impedance	Z _{PWM}	20	40	60	kΩ	
LED_EN High Voltage	V _{LED_EN_H}	2.2	-	5.3	V	
LED_EN Low Voltage	V _{LED_EN_L}	0	-	0.3	V	
Life Time		12,000	-	-	Hrs	12

Product Specification

Note)

1. The measuring position is the connector of LCM and the test conditions are under 25 °C , fv = 60Hz, White pattern.
2. The specified Icc current and power consumption are under the Vcc = 3.3V , 25 °C , fv = 60Hz condition and Mosaic pattern.

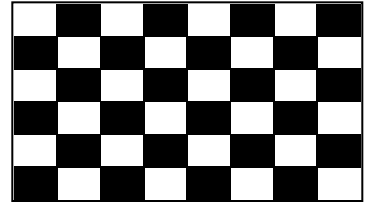

3. This Power Consumption Spec. is measured for the Mosaic Pattern condition.
4. The below figures are the measuring Vcc condition and the Vcc control block LGD used.
The Vcc condition is same as the minimum of T1 at Power on sequence.

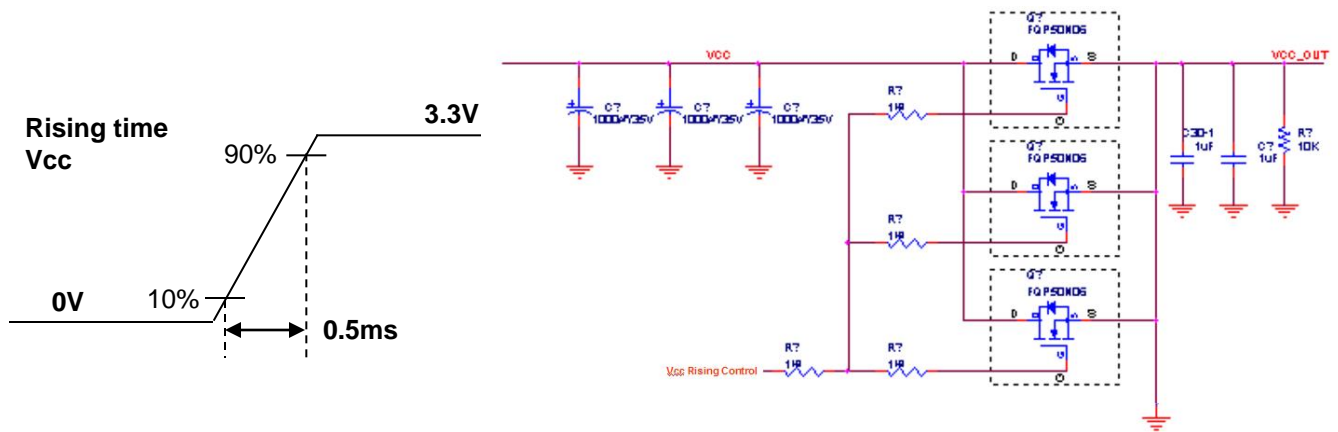

5. This impedance value is needed for proper display and measured form LVDS Tx to the mating connector.
6. The measuring position is the connector of LCM and the test conditions are under 25 °C .
7. The current and power consumption with LED Driver are under the Vled = 12.0V , 25 °C , Dimming of Max luminance and White pattern with the normal frame frequency operated(60Hz).
8. The below figures are the measuring Vled condition and the Vled control block LGD used.
VLED control block is same with Vcc control block.

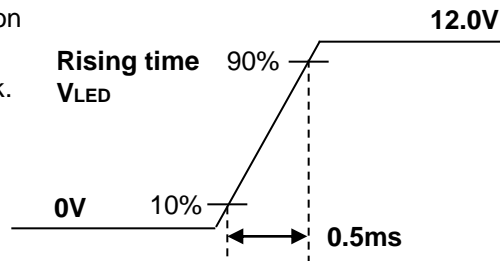

9. The operation of LED Driver below minimum dimming ratio may cause flickering or reliability issue.
10. If Jitter of PWM is bigger than maximum, it may induce flickering.
11. This Spec. is not effective at 100% dimming ratio as an exception because it has DC level equivalent to 0Hz. In spite of acceptable range as defined, the PWM Frequency should be fixed and stable for more consistent brightness control at any specific level desired.
12. The life time is determined as the sum of the continuous operation time at which brightness of LCD at the typical LED current is 50% compare to that of minimum value specified in table 7 under general user condition.

Product Specification

3-2. Interface Connections

This LCD employs two interface connections, a 30 pin connector used for the module electronics interface and the other connector used for the integral backlight system.

The electronics interface connector is a model CABLINE-VS RECE ASS'Y.

Table 3. MODULE CONNECTOR PIN CONFIGURATION (CN1)

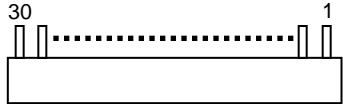
Pin	Symbol	Description	Notes
1	NC	No Connection	<p>[Connector] TBD</p> <p>[Connector pin arrangement]</p>  <p>[LCD Module Rear View]</p> <p>[EDID & LGD P-Vcom Share pin]</p> <p>1. Pin for P-Vcom : #24, #25 2. P-Vcom Address : 01010000</p>
2	GND	High Speed Ground	
3	Lane1_N	Signal Link Negative Lane1	
4	Lane1_P	Signal Link Positive Lane1	
5	GND	High Speed Ground	
6	Lane0_N	Signal Link Negative Lane0	
7	Lane0_P	Signal Link Positive Lane0	
8	GND	High Speed Ground	
9	AUX_P	Signal Auxiliary Positive Ch.	
10	AUX_N	Signal Auxiliary Negative Ch.	
11	GND	High Speed Ground	
12	VCC	LCD Logic and driver power (3.3V Typ.)	
13	VCC	LCD Logic and driver power (3.3V Typ.)	
14	NC	No Connection	
15	GND	High Speed Ground	
16	GND	High Speed Ground	
17	HPD	Hot plug Detection Pin	
18	GND	High Speed Ground	
19	GND	High Speed Ground	
20	GND	High Speed Ground	
21	GND	High Speed Ground	
22	LED_EN	LED Backlight On/Off	
23	PWM	System PWM Signal input for dimming	
24	NC	No Connection	
25	NC	No Connection	
26	VLED	LED Backlight Power (5.5V-21V)	
27	VLED	LED Backlight Power (5.5V-21V)	
28	VLED	LED Backlight Power (5.5V-21V)	
29	VLED	LED Backlight Power (5.5V-21V)	
30	NC	No Connection	

Product Specification

3-3. eDP Signal Timing Specifications

3-3-1. DC Specification

The VESA Display Port related AC specification is compliant with the VESA Display Port Standard.

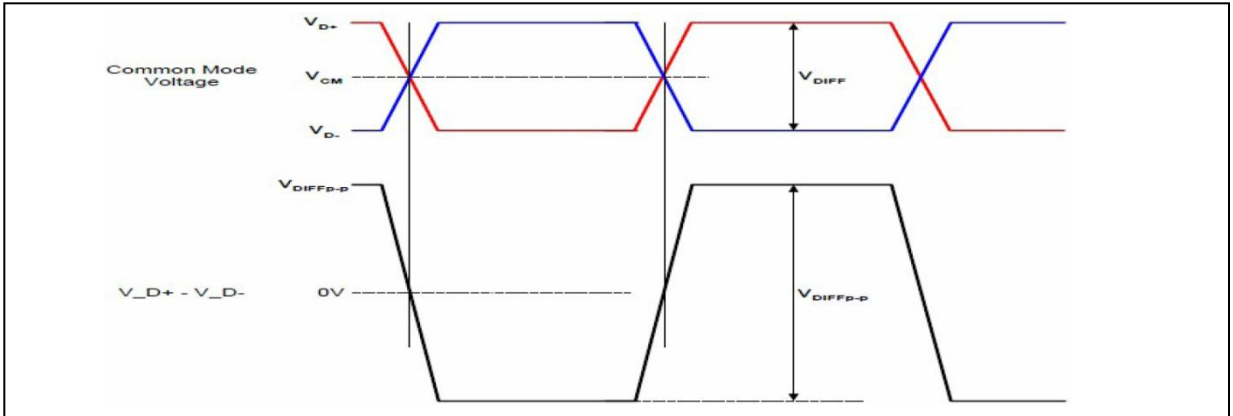

Description	Symbol	Min	Max	Unit	Notes
Differential peak-to-peak Input voltage	V _{DIFF p-p}	120	-	mV	For high bit rate
		40	-		For reduced bit rate
Rx DC common mode voltage	V _{CM}	0	2.0	V	-

3-3-2. AC Specification

The VESA Display Port related AC specification is compliant with the VESA Display Port Standard.

Description	Symbol	Min	Typ	Max	Unit	Notes
Unit Interval for high bit rate (2.7Gbps/lane)	UI_High_Rate	-	370	-	ps	Range is nominal ±350ppm. DisplayPort Link Rx does not require local crystal for link clock generation
Unit Interval for high bit rate (1.62Gbps/lane)	UI_Low_Rate	-	617	-	ps	
Lane-to-Lane skew	V _{Rx-SKEW-INTER_PAIR}	-	-	5200	ps	-
Lane intra-pair skew	V _{Rx-SKEW-INTRA_PAIR}	-	-	100	ps	For high bit rate
		-	-	300	ps	For reduced bit rate

Product Specification

3-4. Signal Timing Specifications

This is the signal timing required at the input of the User connector. All of the interface signal timing should be satisfied with the following specifications and specifications of eDP Tx/Rx for its proper operation.

Table 5. TIMING TABLE

ITEM	Symbol	Min	Typ	Max	Unit	Note
DCLK	Frequency	f_{CLK}	-	138.7	-	MHz
Hsync	Period	T_{hp}	-	2080	-	tCLK
	Width	t_{WH}	-	32	-	
	Width-Active	t_{WHA}	-	1920	-	
Vsync	Period	t_{VP}	-	1111	-	tHP
	Width	t_{WV}	-	5	-	
	Width-Active	t_{WVA}	-	1080	-	
Data Enable	Horizontal back porch	t_{HBP}	-	80	-	tCLK
	Horizontal front porch	t_{HFP}	-	48	-	
	Vertical back porch	t_{VBP}	-	23	-	tHP
	Vertical front porch	t_{VFP}	-	3	-	

Notice. all reliabilities are specified for timing specification based on refresh rate of 60Hz. However, LP173WF4 has a good actual performance even at lower refresh rate (e.g. 40Hz or 50Hz) for power saving Mode, whereas LP173WF4 is secured only for function under lower refresh rate. 60Hz at Normal mode, 50Hz, 40Hz at Power save mode. Don't care Flicker level (power save mode).

3-5. Signal Timing Waveforms

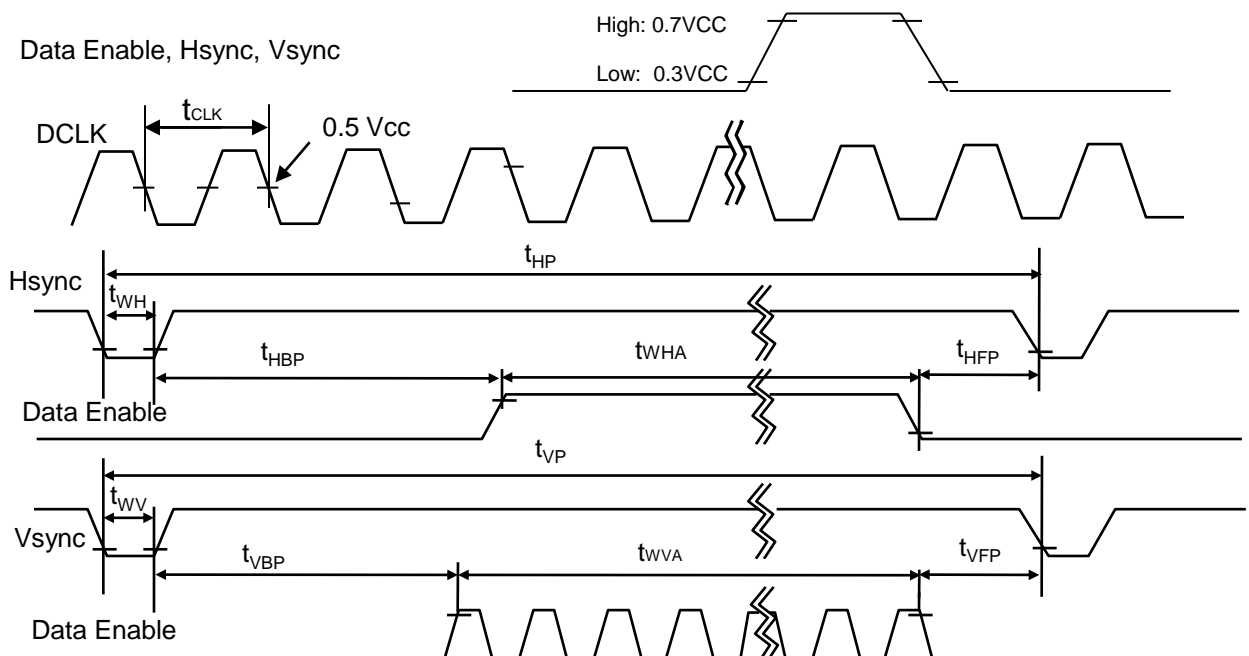
 Condition : $V_{CC} = 3.3V$

Product Specification

3-6. Color Input Data Reference

The brightness of each primary color (red, green and blue) is based on the 6-bit gray scale data input for the color ; the higher the binary input, the brighter the color. The table below provides a reference for color versus data input.

Table 7. COLOR DATA REFERENCE

Color		Input Color Data																	
		RED					GREEN					BLUE							
		MSB		LSB			MSB		LSB			MSB		LSB					
		R5	R4	R3	R2	R1	R0	G5	G4	G3	G2	G1	G0	B5	B4	B3	B2	B1	B0
Basic Color	Black	0	0	0	0	0	0	0	0	0	0	0	0	0	0	0	0	0	0
	Red	1	1	1	1	1	1	0	0	0	0	0	0	0	0	0	0	0	0
	Green	0	0	0	0	0	0	1	1	1	1	1	1	0	0	0	0	0	0
	Blue	0	0	0	0	0	0	0	0	0	0	0	0	1	1	1	1	1	1
	Cyan	0	0	0	0	0	0	1	1	1	1	1	1	1	1	1	1	1	1
	Magenta	1	1	1	1	1	1	0	0	0	0	0	0	1	1	1	1	1	1
	Yellow	1	1	1	1	1	1	1	1	1	1	1	1	0	0	0	0	0	0
	White	1	1	1	1	1	1	1	1	1	1	1	1	1	1	1	1	1	1
RED	RED (00)	0	0	0	0	0	0	0	0	0	0	0	0	0	0	0	0	0	0
	RED (01)	0	0	0	0	0	1	0	0	0	0	0	0	0	0	0	0	0	0
					
	RED (62)	1	1	1	1	1	0	0	0	0	0	0	0	0	0	0	0	0	0
	RED (63)	1	1	1	1	1	1	0	0	0	0	0	0	0	0	0	0	0	0
GREEN	GREEN (00)	0	0	0	0	0	0	0	0	0	0	0	0	0	0	0	0	0	0
	GREEN (01)	0	0	0	0	0	0	0	0	0	0	0	1	0	0	0	0	0	0
					
	GREEN (62)	0	0	0	0	0	0	1	1	1	1	1	0	0	0	0	0	0	0
	GREEN (63)	0	0	0	0	0	0	1	1	1	1	1	1	0	0	0	0	0	0
BLUE	BLUE (00)	0	0	0	0	0	0	0	0	0	0	0	0	0	0	0	0	0	0
	BLUE (01)	0	0	0	0	0	0	0	0	0	0	0	0	0	0	0	0	0	1
					
	BLUE (62)	0	0	0	0	0	0	0	0	0	0	0	0	1	1	1	1	1	0
	BLUE (63)	0	0	0	0	0	0	0	0	0	0	0	0	1	1	1	1	1	1

Product Specification

3-7. Power Sequence

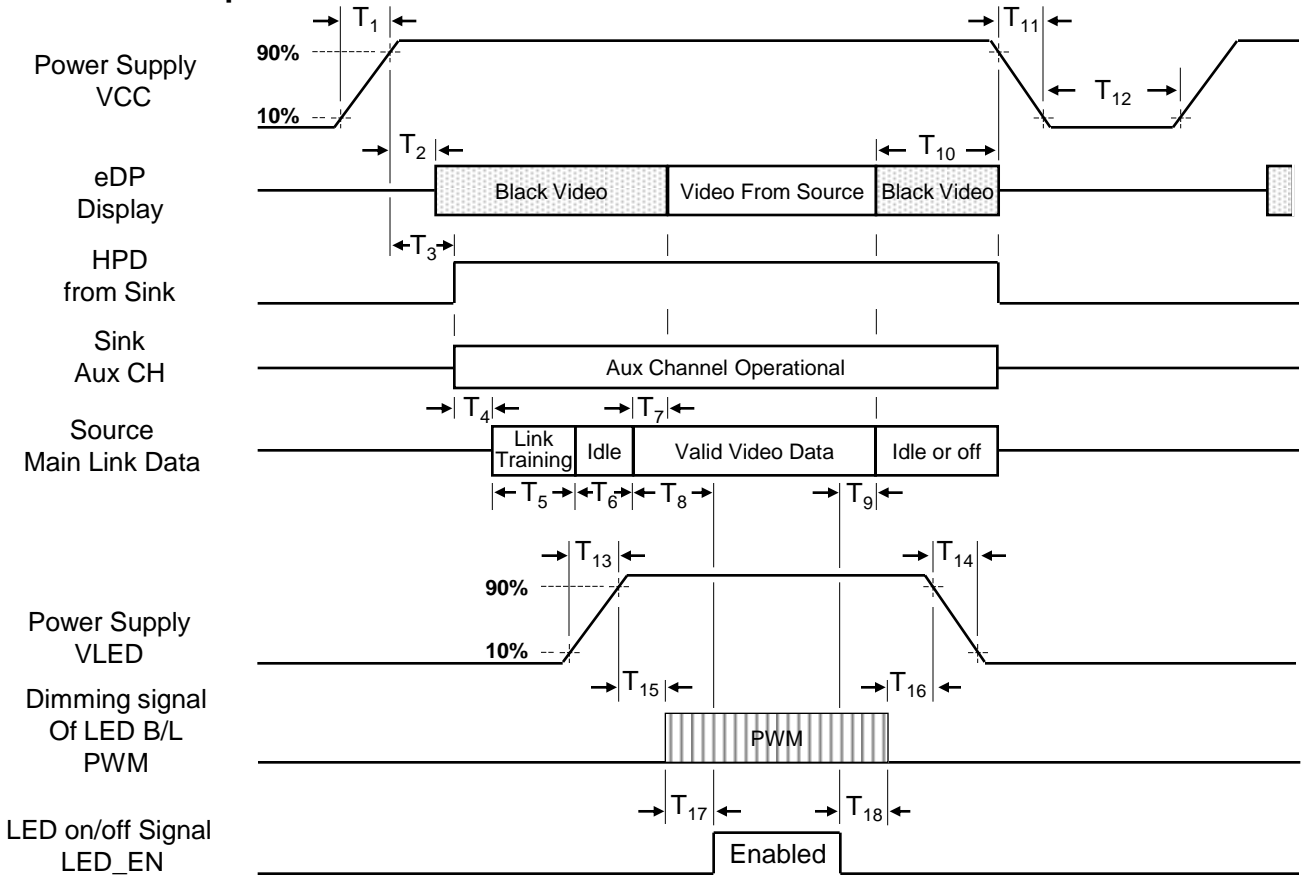

Table 6. POWER SEQUENCE TABLE

Timing	Required By	Limits		Units	Notes
		Min	Max		
T ₁	Source	0.5	10	ms	-
T ₂	Sink	0	200	ms	-
T ₃	Sink	0	200	ms	-
T ₄	Source	-	-	ms	-
T ₅	Source	-	-	ms	-
T ₆	Source	-	-	ms	-
T ₇	Sink	0	50	ms	-
T ₈	Source	-	-	ms	LGD recommend Min 200ms
T ₉	Source	-	-	ms	-

Timing	Required By	Limits		Units	Notes
		Min	Max		
T ₁₀	Source	0	500	ms	-
T ₁₁	Source	-	10	ms	-
T ₁₂	Source	500	-	ms	-
T ₁₃	Source	0.5	10	ms	-
T ₁₄	Source	0.5	10	ms	-
T ₁₅	Source	10	-	ms	-
T ₁₆	Source	10	-	ms	-
T ₁₇	Source	0	-	ms	-
T ₁₈	Source	0	-	ms	-

- Note) 1. Do not insert the mating cable when system turn on.
 2. Valid Data have to meet "3-3. eDP Signal Timing Specifications"
 3. Video Signal, LED_EN and PWM need to be on pull-down condition on invalid status.
 4. LGD recommend the rising sequence of VLED after the Vcc and valid status of Video Signal turn on.

4. Optical Specification

Optical characteristics are determined after the unit has been 'ON' and stable for approximately 30 minutes in a dark environment at 25°C. The values specified are at an approximate distance 50cm from the LCD surface at a viewing angle of Φ and Θ equal to 0°.

FIG. 1 presents additional information concerning the measurement equipment and method.

FIG. 1 Optical Characteristic Measurement Equipment and Method

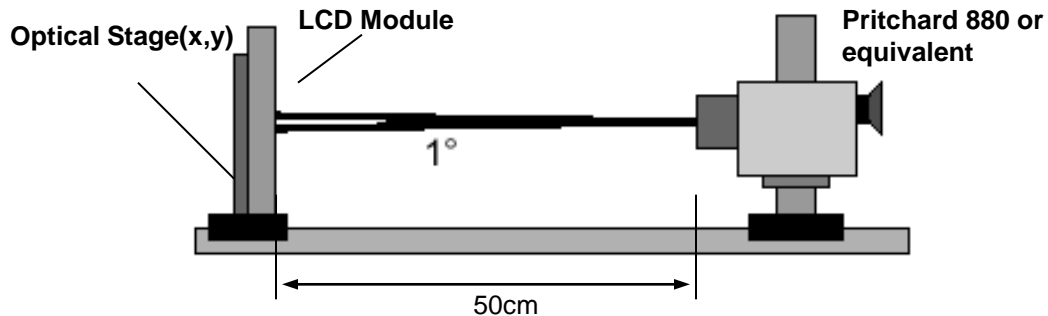

Table 8. OPTICAL CHARACTERISTICS

Ta=25°C, VCC=3.3V, fv=60Hz

Parameter	Symbol	Values			Units	Notes
		Min	Typ	Max		
Contrast Ratio	CR	500	600	-		1
Surface Luminance, white	L _{WH}	255	300	-	cd/m ²	2
Luminance Variation	δ_{WHITE}	-	1.4	1.6		3
Response Time	Tr _R +Tr _D	-	25	30	ms	4
Color Coordinates						
RED	RX	TBD	TBD	TBD		
	RY	TBD	TBD	TBD		
GREEN	GX	TBD	TBD	TBD		
	GY	TBD	TBD	TBD		
BLUE	BX	TBD	TBD	TBD		
	BY	TBD	TBD	TBD		
WHITE	WX	0.283	0.313	0.343		
	WY	0.299	0.329	0.359		
Viewing Angle						
x axis, right($\Phi=0^\circ$)	Θ_r	80	-	-	degree	5
x axis, left ($\Phi=180^\circ$)	Θ_l	80	-	-	degree	
y axis, up ($\Phi=90^\circ$)	Θ_u	80	-	-	degree	
y axis, down ($\Phi=270^\circ$)	Θ_d	80	-	-	degree	
Color Gamut	C/G	-	72	-	%	

Product Specification

Note)

1. It should be measured in the center of screen. Contrast Ratio(CR) is defined mathematically as

$$\text{Contrast Ratio} = \frac{\text{Surface Luminance with all white pixels}}{\text{Surface Luminance with all black pixels}}$$

2. Surface luminance is the average of 5 point across the LCD surface 50cm from the surface with all pixels displaying white. For more information see FIG 1.

$$L_{\text{WH}} = \text{Average}(L_1, L_2, \dots L_5)$$

3. The variation in surface luminance , The panel total variation (δ_{WHITE}) is determined by measuring L_N at each test position 1 through 13 and then defined as followed numerical formula.
For more information see FIG 2.

$$\delta_{\text{WHITE}} = \frac{\text{Maximum}(L_1, L_2, \dots L_{13})}{\text{Minimum}(L_1, L_2, \dots L_{13})}$$

4. Response time is the time required for the display to transition from white to black (rise time, Tr_R) and from black to white(Decay Time, Tr_D). For additional information see FIG 3.
5. Viewing angle is the angle at which the contrast ratio is greater than 10. The angles are determined for the horizontal or x axis and the vertical or y axis with respect to the z axis which is normal to the LCD surface. For more information see FIG 4.

Product Specification

5. Mechanical Characteristics

The contents provide general mechanical characteristics for the model LP173WF4. In addition the figures in the next page are detailed mechanical drawing of the LCD.

Outline Dimension	Horizontal	399.5 ± 0.5 mm
	Vertical	241.95 ± 0.5 mm (w/o PCB)
	Thickness	4.0mm (Max.) (w/o PCB)
Active Display Area	Horizontal	381.89mm
	Vertical	214.81 mm
Weight	550.0g (Max.)	
Surface Treatment	Anti Glare treatment of the front polarizer	

Product Specification

<FRONT VIEW>

Note) Unit:[mm], General tolerance: $\pm 0.5\text{mm}$

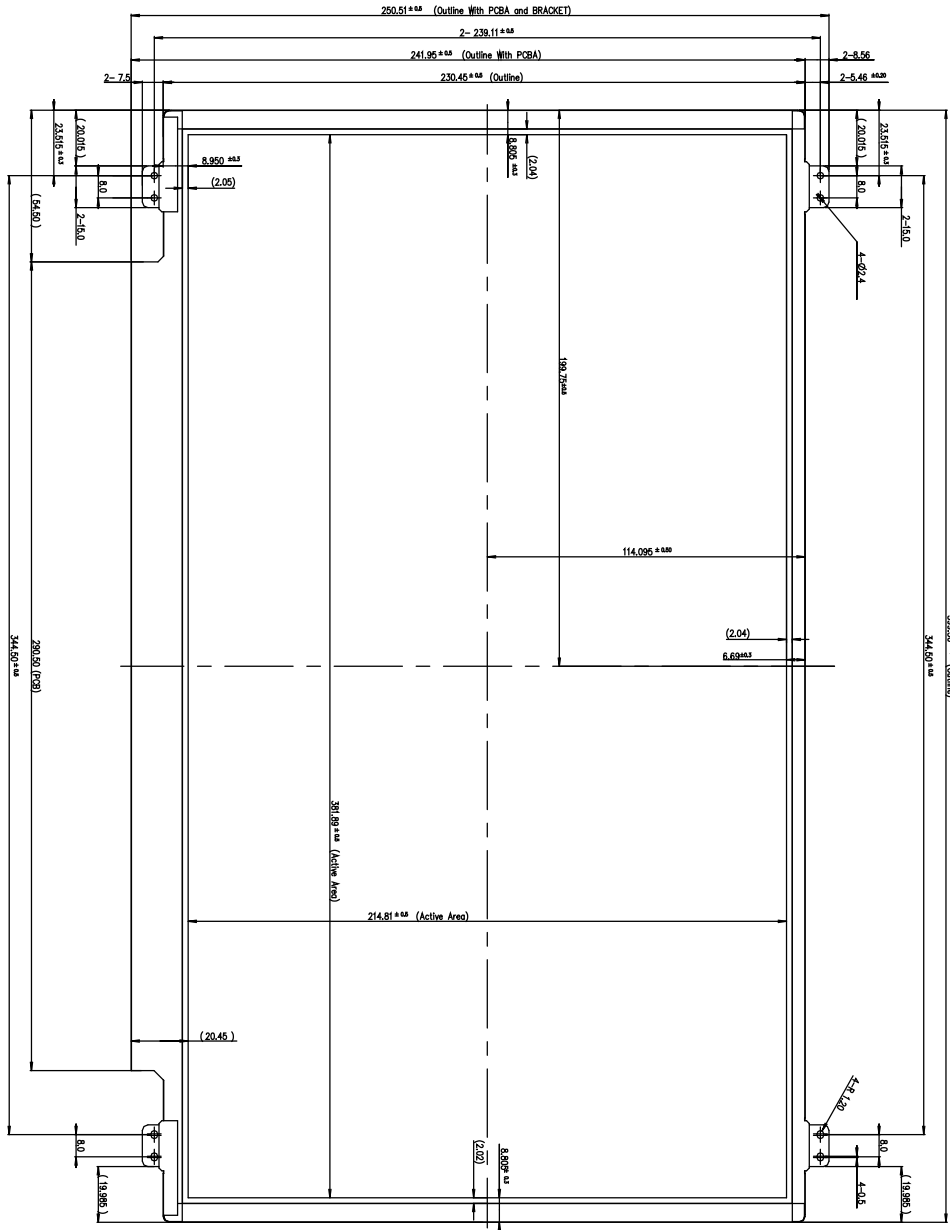

Product Specification

<REAR VIEW>

Note) Unit:[mm], General tolerance: ± 0.5mm

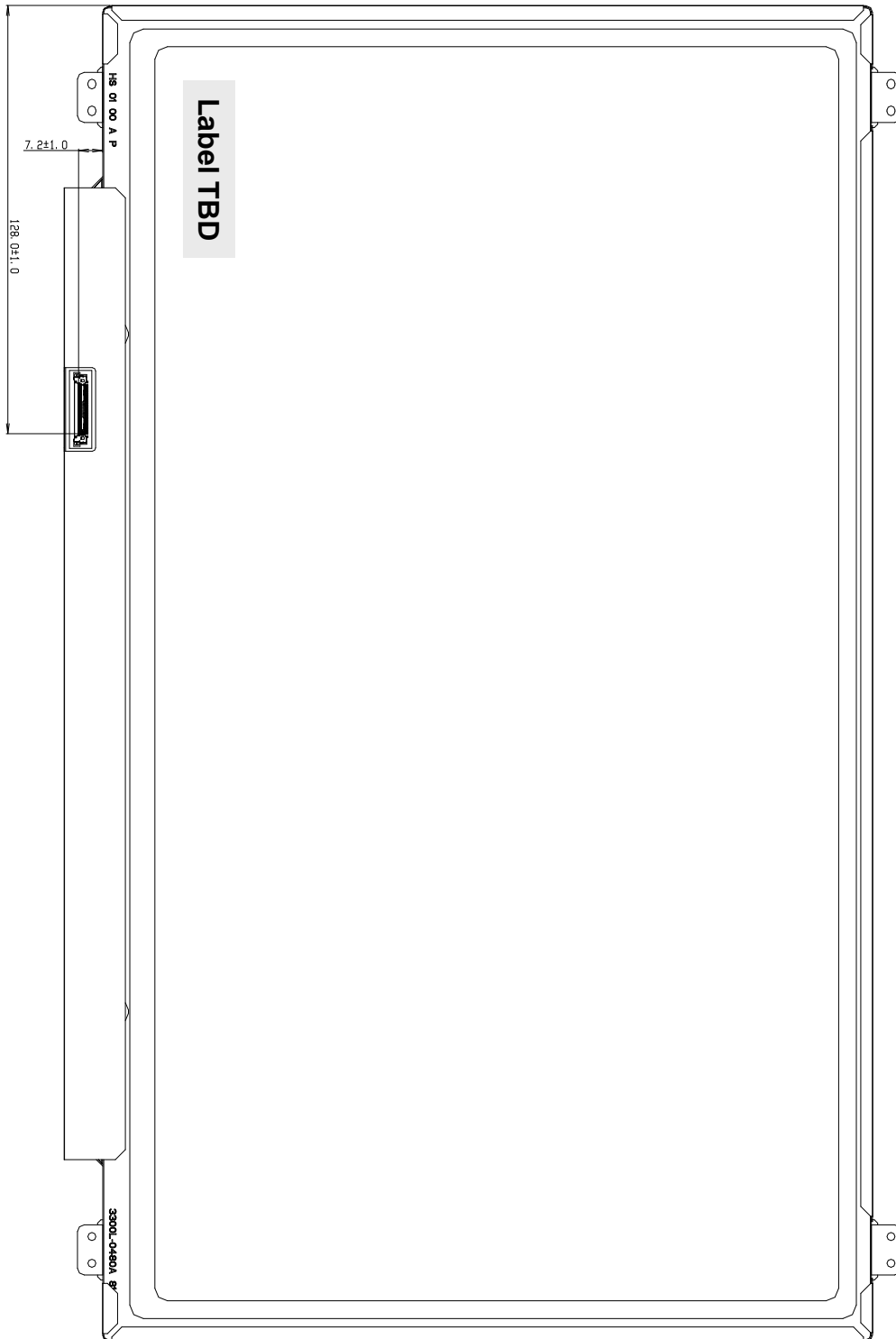

LGD Proposal for system cover design.(Appendix)

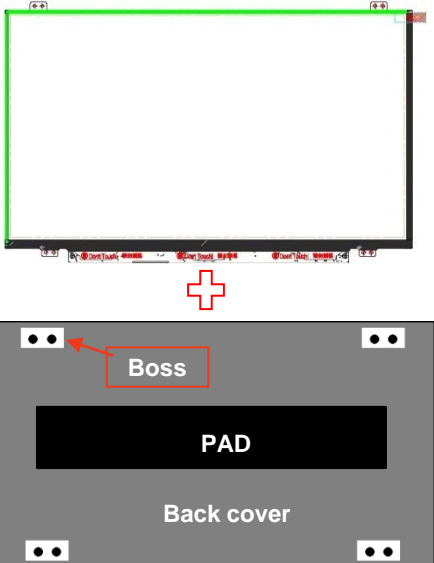
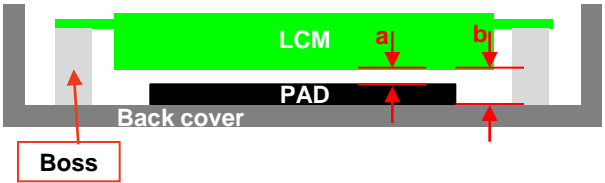
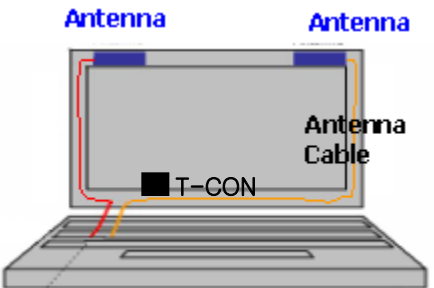
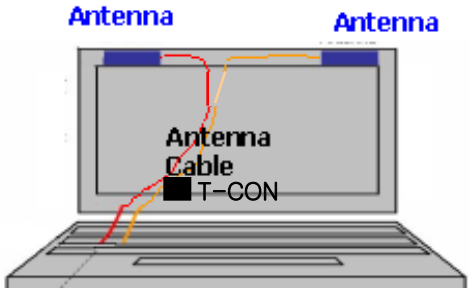
<p>1</p>	<p>Gap check for securing the enough gap between LCM and System back cover.</p>
<div style="display: flex; justify-content: space-around; align-items: flex-start;"> <div style="text-align: center;">  <p>LCM</p> <p>Back cover</p> <p>BOSS</p> <p>PAD</p> </div> <div style="text-align: center;">  <p>LCM</p> <p>Back cover</p> <p>PAD</p> <p>BOSS</p> <p>a</p> <p>b</p> </div> <div style="background-color: #c8e6c9; padding: 5px; border: 1px solid #455a64;"> <p>◆ a : min 0mm</p> <p>◆ b : min 0.3mm, Max 1.0mm</p> </div> </div>	
<p>Define</p>	<p>1.Rear side of LCM is sensitive against external stress, and previous check about interference is highly needed.</p> <p>2.In case there is something from system cover comes into the boundary above,mechanical interference may cause the FOS defects. (Eg: Ripple, White spot..)</p>
<p>2</p>	<p>Check if antenna cable is sufficiently apart from T-CON of LCD Module.</p>
<div style="display: flex; justify-content: space-around; align-items: center;"> <div style="text-align: center;">  <p>Antenna</p> <p>Antenna</p> <p>Antenna Cable</p> <p>T-CON</p> <p>OK</p> </div> <div style="text-align: center;">  <p>Antenna</p> <p>Antenna</p> <p>Antenna Cable</p> <p>T-CON</p> <p>NG</p> </div> </div>	
<p>Define</p>	<p>1.If system antenna is overlapped with T-CON,it might be cause the noise</p>

LGD Proposal for system cover design.(Appendix)

<p>3</p>	<p>Checking the path of the System wire</p>
<p>Define</p>	<p>1.If Wire path overlapped with LCM, it is happened white spot, COF problem, etc. 2.OK → Wire path design to system side. NG → Wire path overlapped with LCM.</p>
<p>4</p>	<p>Add pad to Prevent panel crack against external load (push)</p>
<p>Define</p>	<p>1. At flat type LCM, panel is easily cracked at flange area during push, assemble. 2. Add pad, it prevent panel crack</p>

LGD Proposal for system cover design.(Appendix)

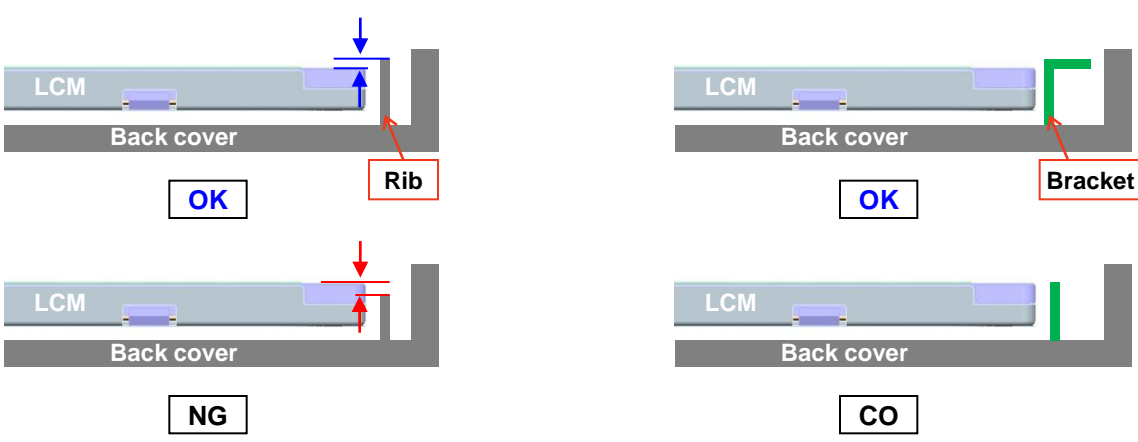
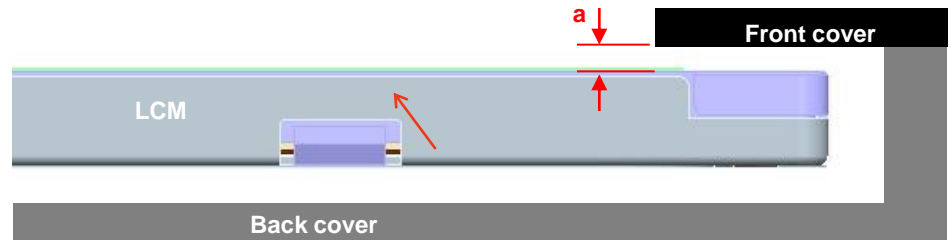
5	Check the rib or Bracket on back cover
	
Define	<p>1.It is necessary that the height of back cover rib or bracket is higher than LCM height. It can prevent direct compression of panel at LCM edge.</p> <p>2."┌" shape bracket is stronger than "I" shape one.</p>
6	Check the gap between front cover and LCM(glass)
 <div data-bbox="271 1526 821 1671" style="background-color: #c8e6c9; padding: 10px; margin-top: 10px;"> <p>[OK] $a \geq 0.3\text{mm}$ [CO] $0.3\text{mm} \geq a \geq 0.1\text{mm}$ [NG] $a \leq 0.1\text{mm}$</p> </div>	
Define	1. Ripple can be happened by little gap between glass and front cover.

LGD Proposal for system cover design.(Appendix)

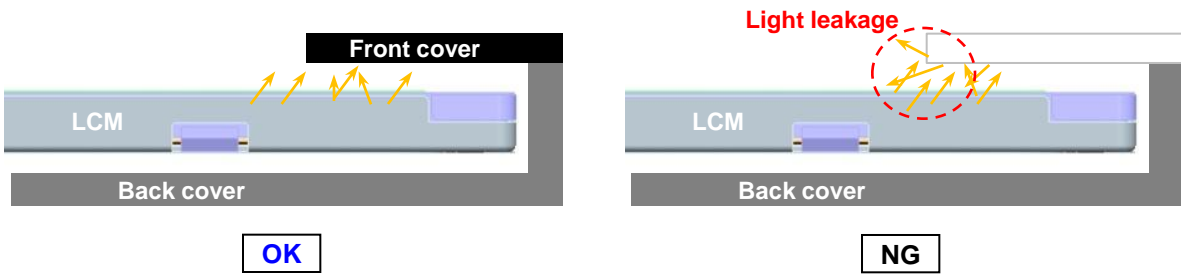
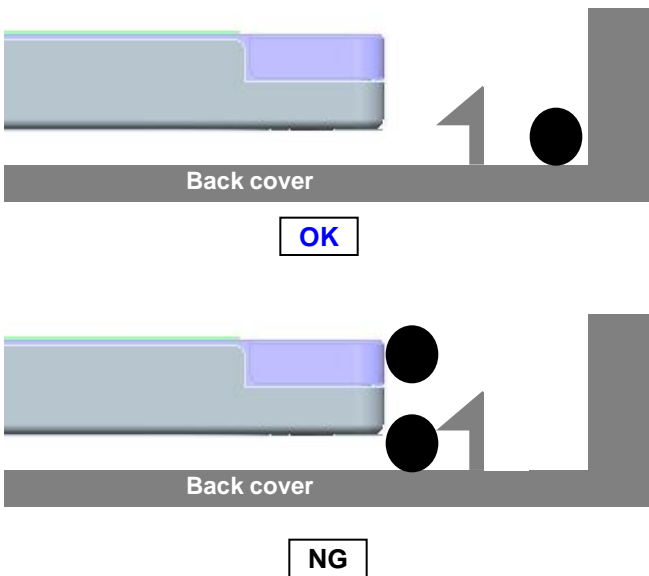
7	Check the rib or Bracket on back cover
 <p>The diagram illustrates two scenarios for the LCM assembly on the back cover. In the 'OK' scenario, the front cover is properly seated, and light rays (yellow arrows) are contained within the LCM. In the 'NG' scenario, the front cover is not seated correctly, causing light rays to escape through the gap, labeled as 'Light leakage' in red. Labels 'LCM' and 'Back cover' are present in both diagrams.</p>	
Define	<p>1.If it is possible, shrink to apply front cover of white color. 2. White color can caused light leakage</p>
8	Check the wire position(path)
 <p>The diagram shows two wire placement scenarios on the back cover. The 'OK' scenario shows the wire positioned away from the hook. The 'NG' scenario shows the wire positioned near the hook, which could lead to assembly errors or cracks. Labels 'Back cover' are present in both diagrams.</p>	
Define	<p>1. It is necessary that wire is posited out of hook, not posited near hook,..... 2. If wire is posited near hook, it can be happened assemble error and panel crack during assemble front cover</p>

LGD Proposal for system cover design.(Appendix)

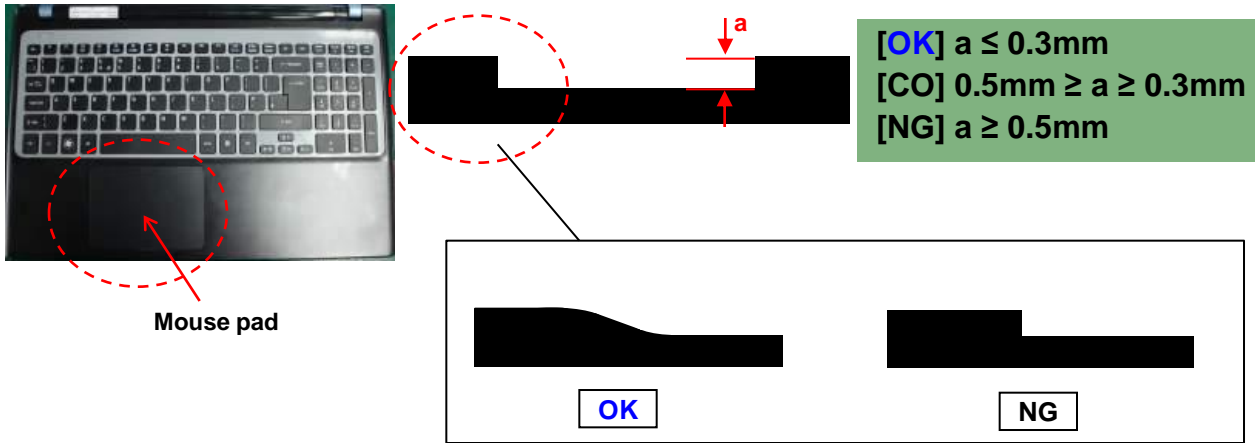
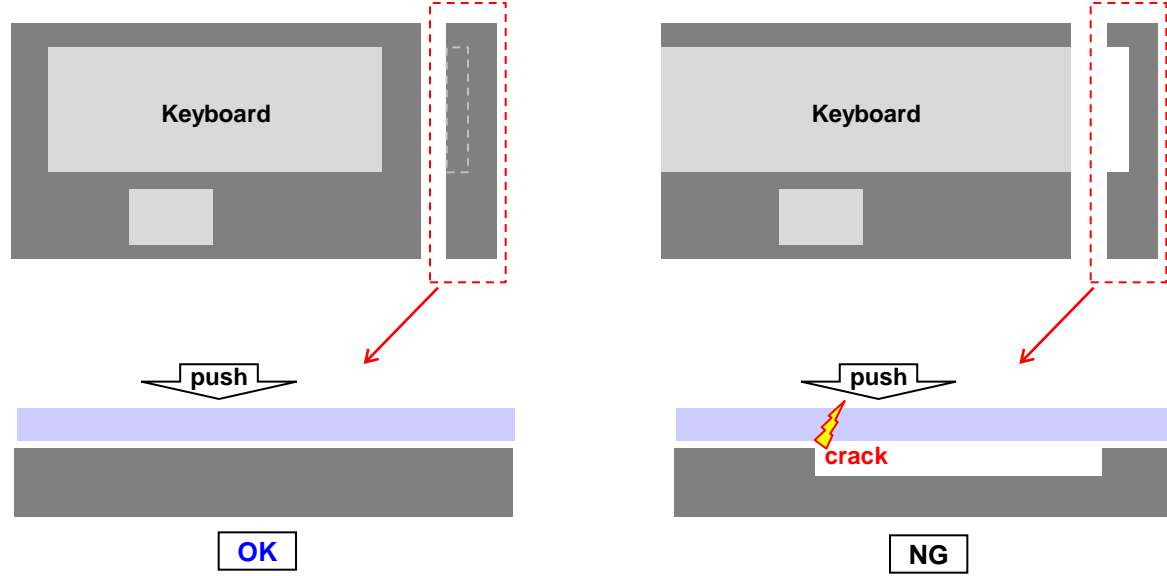
9	Check mouse pad (touch pad) depth and shape of edge
 <p>[OK] $a \leq 0.3\text{mm}$ [CO] $0.5\text{mm} \geq a \geq 0.3\text{mm}$ [NG] $a \geq 0.5\text{mm}$</p> <p>OK NG</p>	
Define	<p>1. Mouse pad step is deep, it is caused panel crack by external load.</p> <p>2. The edge shape must be smooth.</p>
10	Check the step of keyboard area
 <p>Keyboard Keyboard</p> <p>push push</p> <p>OK NG</p>	
Define	<p>1. The step of keyboard at the side edge of main body, it is caused panel crack</p>

Product Specification

6. Reliability

Environment test condition

No.	Test Item	Conditions
1	High temperature storage test	Ta= 60°C, 240h
2	Low temperature storage test	Ta= -20°C, 240h
3	High temperature operation test	Ta= 50°C, 50%RH, 240h
4	Low temperature operation test	Ta= 0°C, 240h
5	Vibration test (non-operating)	Sine wave, 10 ~ 500 ~ 10Hz, 1.5G, 0.37oct/min 3 axis, 1hour/axis
6	Shock test (non-operating)	Half sine wave, 180G, 2ms one shock of each six faces(I.e. run 180G 6ms for all six faces)
7	Altitude operating storage / shipment	0 ~ 10,000 feet (3,048m) 24Hr 0 ~ 40,000 feet (12,192m) 24Hr

{ Result Evaluation Criteria }

There should be no change which might affect the practical display function when the display quality test is conducted under normal operating condition.

7. International Standards

7-1. Safety

- a) UL 60950-1, Underwriters Laboratories Inc.
Information Technology Equipment - Safety - Part 1 : General Requirements.
- b) CAN/CSA-C22.2 No. 60950-1-07, Canadian Standards Association.
Information Technology Equipment - Safety - Part 1 : General Requirements.
- c) EN 60950-1, European Committee for Electrotechnical Standardization (CENELEC).
Information Technology Equipment - Safety - Part 1 : General Requirements.
- d) IEC 60950-1, The International Electrotechnical Commission (IEC).
Information Technology Equipment - Safety - Part 1 : General Requirements

7-2. Environment

- a) RoHS, Directive 2011/65/EU of the European Parliament and of the council of 8 June 2011

Product Specification

8. Packing

8-1. Designation of Lot Mark

a) Lot Mark

A	B	C	D	E	F	G	H	I	J	K	L	M
---	---	---	---	---	---	---	---	---	---	---	---	---

A,B,C : SIZE(INCH)
E : MONTH

D : YEAR
F ~ M : SERIAL NO.

Note

1. YEAR

Year	2011	2012	2013	2014	2015	2016	2017	2018	2019	2020
Mark	A	B	C	D	E	F	G	H	J	K

2. MONTH

Month	Jan	Feb	Mar	Apr	May	Jun	Jul	Aug	Sep	Oct	Nov	Dec
Mark	1	2	3	4	5	6	7	8	9	A	B	C

b) Location of Lot Mark

Serial No. is printed on the label. The label is attached to the backside of the LCD module.
This is subject to change without prior notice.

8-2. Packing Form

a) Package quantity in one box : TBD pcs

b) Box Size : TBD mm

9. PRECAUTIONS

Please pay attention to the followings when you use this TFT LCD module.

9-1. MOUNTING PRECAUTIONS

- (1) You must mount a module using holes arranged in four corners or four sides.
- (2) You should consider the mounting structure so that uneven force (ex. Twisted stress) is not applied to the module. And the case on which a module is mounted should have sufficient strength so that external force is not transmitted directly to the module.
- (3) Please attach the surface transparent protective plate to the surface in order to protect the polarizer. Transparent protective plate should have sufficient strength in order to resist external force.
- (4) You should adopt radiation structure to satisfy the temperature specification.
- (5) Acetic acid type and chlorine type materials for the cover case are not desirable because the former generates corrosive gas of attacking the polarizer at high temperature and the latter causes circuit break by electro-chemical reaction.
- (6) Do not touch, push or rub the exposed polarizers with glass, tweezers or anything harder than HB pencil lead. And please do not rub with dust clothes with chemical treatment. Do not touch the surface of polarizer for bare hand or greasy cloth.(Some cosmetics are detrimental to the polarizer.)
- (7) When the surface becomes dusty, please wipe gently with absorbent cotton or other soft materials like chamois soaks with petroleum benzene. Normal-hexane is recommended for cleaning the adhesives used to attach front / rear polarizers. Do not use acetone, toluene and alcohol because they cause chemical damage to the polarizer.
- (8) Wipe off saliva or water drops as soon as possible. Their long time contact with polarizer causes deformations and color fading.
- (9) Do not open the case because inside circuits do not have sufficient strength.

9-2. OPERATING PRECAUTIONS

- (1) The spike noise causes the mis-operation of circuits. It should be lower than following voltage :
 $V = \pm 200\text{mV}$ (Over and under shoot voltage)
- (2) Response time depends on the temperature.(In lower temperature, it becomes longer.)
- (3) Brightness depends on the temperature. (In lower temperature, it becomes lower.)
And in lower temperature, response time(required time that brightness is stable after turned on) becomes longer.
- (4) Be careful for condensation at sudden temperature change. Condensation makes damage to polarizer or electrical contacted parts. And after fading condensation, smear or spot will occur.
- (5) When fixed patterns are displayed for a long time, remnant image is likely to occur.
- (6) Module has high frequency circuits. Sufficient suppression to the electromagnetic interference shall be done by system manufacturers. Grounding and shielding methods may be important to minimized the interference.

Product Specification

9-3. ELECTROSTATIC DISCHARGE CONTROL

Since a module is composed of electronic circuits, it is not strong to electrostatic discharge. Make certain that treatment persons are connected to ground through wrist band etc. And don't touch interface pin directly.

9-4. PRECAUTIONS FOR STRONG LIGHT EXPOSURE

Strong light exposure causes degradation of polarizer and color filter.

9-5. STORAGE

When storing modules as spares for a long time, the following precautions are necessary.

- (1) Store them in a dark place. Do not expose the module to sunlight or fluorescent light. Keep the temperature between 5°C and 35°C at normal humidity.
- (2) The polarizer surface should not come in contact with any other object.
It is recommended that they be stored in the container in which they were shipped.

9-6. HANDLING PRECAUTIONS FOR PROTECTION FILM

- (1) When the protection film is peeled off, static electricity is generated between the film and polarizer.
This should be peeled off slowly and carefully by people who are electrically grounded and with well ion-blown equipment or in such a condition, etc.
- (2) The protection film is attached to the polarizer with a small amount of glue. If some stress is applied to rub the protection film against the polarizer during the time you peel off the film, the glue is apt to remain on the polarizer.
Please carefully peel off the protection film without rubbing it against the polarizer.
- (3) When the module with protection film attached is stored for a long time, sometimes there remains a very small amount of glue still on the polarizer after the protection film is peeled off.
- (4) You can remove the glue easily. When the glue remains on the polarizer surface or its vestige is recognized, please wipe them off with absorbent cotton waste or other soft material like chamois soaked with normal-hexane.

9-7. THE LGD QA RESPONSIBILITY WILL BE AVOIDED IN CASE OF BELOW

- (1) When the customer attaches TSM(Touch Sensor Module) on LCM without Supplier's approval.
- (2) When the customer attaches cover glass on LCM without Supplier's approval.
- (3) When the LCMs were repaired by 3rd party without Supplier's approval.
- (4) When the LCMs were treated like Disassemble and Rework by the Customer and/or Customer's representatives without supplier's approval.

APPENDIX A. Enhanced Extended Display Identification Data (EEDID™) 1/3

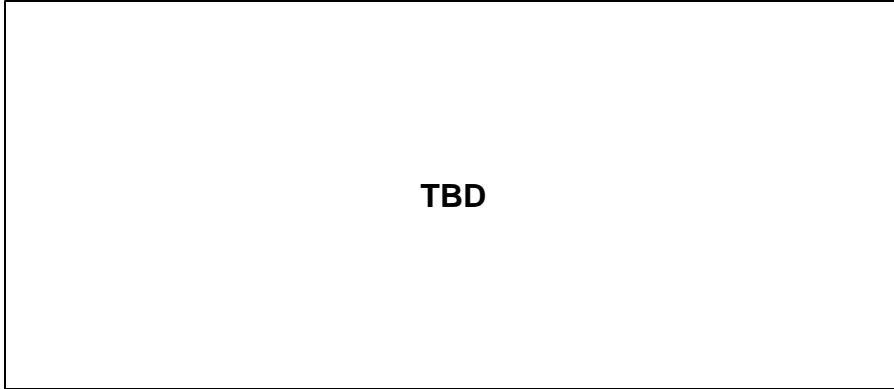

APPENDIX A. Enhanced Extended Display Identification Data (EEDID™) 2/3

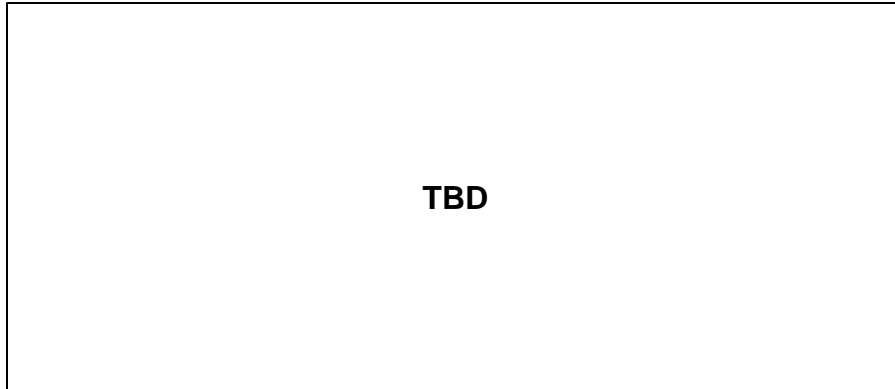

APPENDIX A. Enhanced Extended Display Identification Data (EEDID™) 3/3

