



1.2A Single-chip Li-ion and Li-POL Charge

General Description

The LP28056S is a complete constant-current / constant-voltage linear charger for single cell lithium-ion batteries. Its ESOP-8 package and low external component count make the LP28056S ideally suited for portable applications. No external sense resistor is needed, and no blocking diode is required due to the internal MOSFET architecture. Thermal feedback regulates the charge current to limit the die temperature during high power operation or high ambient temperature. The charge voltage is fixed at 4.2V, and the charge current can be ISET ramed externally with a single resistor. The LP28056S automatically terminates the charge cycle when the charge current drops to 1/10th the R_{ISET} ramed value after the final float voltage is reached. When the input supply is removed, the LP28056S automatically enters a low current state, dropping the battery drain current to less than 1µA. The LP28056S can be put into shutdown mode, reducing the supply current to 1µA.

Other features include charge current monitor, under voltage lockout, automatic recharge and a status pin to indicate charge termination and the presence of an input voltage.

Order Information

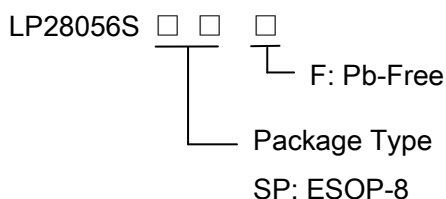

Features

- ◆ Programmable Charge Current Up to 1200mA
- ◆ No MOSFET, Sense Resistor or Blocking Diode Required
- ◆ Constant-Current/Constant-Voltage Operation with Thermal Regulation to Maximize Charge Rate Without Risk of Overheating
- ◆ 4.2V Charge Voltage with ± 1% Accuracy
- ◆ 1µA Supply Current in Shutdown
- ◆ Short-circuit protection
- ◆ Consumption Available in ESOP-8 Package
- ◆ RoHS Compliant and 100% Lead (Pb)-Free

Applications

- ✧ Portable Media Players/MP3 players
- ✧ Cellular and Smart mobile phone
- ✧ PDA/DSC
- ✧ Bluetooth Applications

Marking Information

Device	Marking	Package	Shipping
LP28056SSPF	LPS LP28056S YWX	ESOP-8	2.5K/REEL
Marking indication: Y:Production year W:Production week X:Production batch.			



Typical Application Circuit

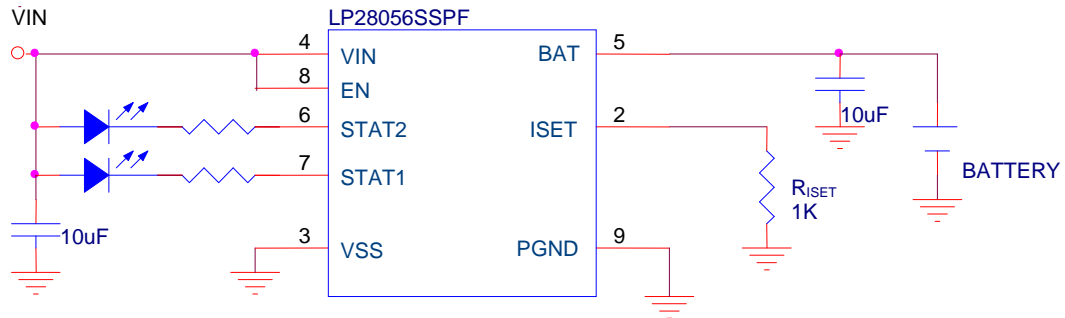

Functional Pin Description

Package Type	Pin Configurations
ESOP-8	

Pin Description

Pin	Name	Description
1	NC	No Connector.
2	ISET	Charge Current Program, Charge Current Monitor and Shutdown Pin. The charge current is programmed by connecting a 1% resistor(R_{PROG})to ground. When charging in constant-current mode, this pin servos to 2V. In all modes, the voltage on this pin can be used to measure the charge current using the following formula: $I_{SET}=1000/R_{PROG}$
3	VSS	VSS is the connection to system ground.
4	VIN	VIN is the input power source. Connect to a wall adapter.
5	BAT	BAT is the connection to the battery. Typically a 10 μ F Tantalum capacitor is needed for stability when there is no battery attached. When a battery is attached, only a 0.1 μ F ceramic capacitor is required.
6	STAT2	Open-Drain Charge Status Output. When the battery is charging, the STAT pin is pulled High by an internal N-channel MOSFET. When the charge cycle is completed, the pin is pulled Low.
7	STAT1	Open-Drain Charge Status Output. When the battery is charging, the STAT pin is pulled low by an internal N-channel MOSFET. When the charge cycle is completed, the pin is pulled High.
8	EN	Chip enable pin. Charging when the pin is floating or connected to a high voltage. Discharge when the pin pull low.



Function Block Diagram

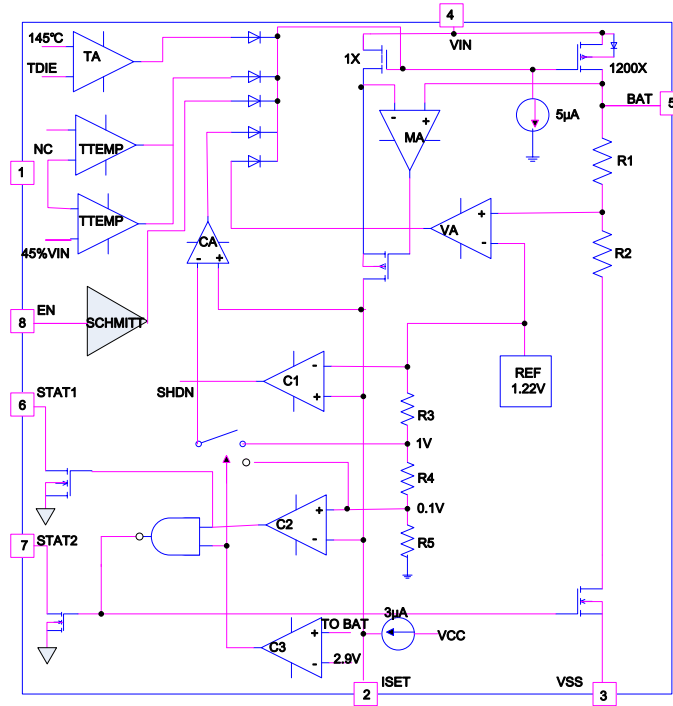

Absolute Maximum Ratings ^{Note 1}

- ✧ Input to GND ----- -0.3V to 7V
- ✧ Other Pin to GND ($V_{ISET}, V_{BAT}, V_{STAT1}, V_{STAT2}$) ----- -0.3V to 6.5V
- ✧ BAT Pin Current ----- 1500mA
- ✧ BAT Short-circuit Duration ----- Continuous
- ✧ Maximum Junction Temperature ----- 150°C
- ✧ Storage Temperature ----- -45°C to 165°C
- ✧ Operating Ambient Temperature Range ----- -20°C to 85°C
- ✧ Maximum Soldering Temperature (at leads, 10 sec) ----- 260°C

Note 1. Stresses beyond those listed under “Absolute Maximum Ratings” may cause permanent damage to the device. These are stress ratings only, and functional operation of the device at these or any other conditions beyond those indicated in the operational sections of the specifications is not implied. Exposure to absolute maximum rating conditions for extended periods may affect device reliability.

Thermal Information

- ✧ Maximum Power Dissipation ($P_D, T_A=25^\circ\text{C}$) ----- 2W
- ✧ Thermal Resistance (θ_{JA}) ----- 50°C/W

ESD Susceptibility

- ✧ HBM(Human Body Mode) ----- 2KV
- ✧ MM(Machine Mode) ----- 200V



Electrical Characteristics

($T_A=25^{\circ}\text{C}$. $V_{IN}=5\text{V}$, unless otherwise noted.)

Symbol	Parameter	Condition	Min	Typ	Max	Units
V_{IN}	Adapter/USB Voltage Range		3.9	5	6	V
I_{CC}	Input Supply Current	Charge Mode, $R_{ISET}=10\text{k}$		300	2000	μA
		Standby Mode (Charge Terminated)		200	500	
		Shutdown Mode (R_{ISET} NC / $V_{EN}=0\text{V}$)		1	5	
V_{FLOAT}	Regulated Output (Float) Voltage	$I_{BAT}=40\text{mA}$	4.158	4.2	4.242	V
I_{BAT}	BAT Pin Current	$R_{ISET}=1\text{k}$	800	1000	1200	mA
		$R_{ISET}=2\text{k}$	400	500	600	
		Standby Mode, $V_{BAT}=4.2\text{V}$ Shutdown Mode (R_{ISET} NC) Sleep Mode, $V_{IN}=0\text{V}$	0	-2.5 ± 1	-6 ± 2	μA
I_{TRIKL}	Trickle Charge Current	$V_{BAT}<V_{TRIKL}$, $R_{ISET}=2\text{k}$,	45	50	55	mA
V_{TRIKL}	Trickle Charge Threshold Voltage	$R_{ISET}=10\text{k}$, V_{BAT} Rising	2.8	2.9	3.0	V
V_{TRHYS}	Trickle Charge Hysteresis Voltage	$R_{ISET}=10\text{k}$	60	80	110	mV
V_{UV}	V_{IN} Under voltage Lockout Threshold	From V_{IN} Low to High	3.7	3.8	3.95	V
V_{UVHYS}	V_{IN} Under voltage Lockout Hysteresis		150	200	300	mV
V_{ASD}	$V_{IN}-V_{BAT}$ Lockout Threshold Voltage	V_{IN} from Low to High		100		mV
		V_{IN} from High to Low		50		
I_{TERM}	C/10 Termination Current Threshold	$R_{ISET}=10\text{k}$		10		$\%I_{BAT}$
		$R_{ISET}=2\text{k}$		10		
V_{ISET}	ISET Pin Voltage	$R_{ISET}=10\text{k}$, Current Mode	1.8	2.0	2.2	V
I_{STAT}	STAT Pin Weak Pull-Down Current	$V_{STAT}=5\text{V}$	0		5	μA
V_{STAT}	STAT Pin Output Low Voltage	$I_{STAT}=5\text{mA}$		0.35	0.6	V
ΔV_{RECHRG}	Recharge Battery Threshold Voltage	$V_{FLOAT}-V_{RECHRG}$	100	150	200	mV
T_{LIM}	Junction Temperature in Constant Temperature Mode			150		$^{\circ}\text{C}$
R_{ON}	Power FET "ON" Resistance (Between V_{IN} and BAT)			300		m Ω



TYPICAL CHARACTERISTICS
DROPOUT VOLTAGE
VS
JUNCTION TEMPERATURE

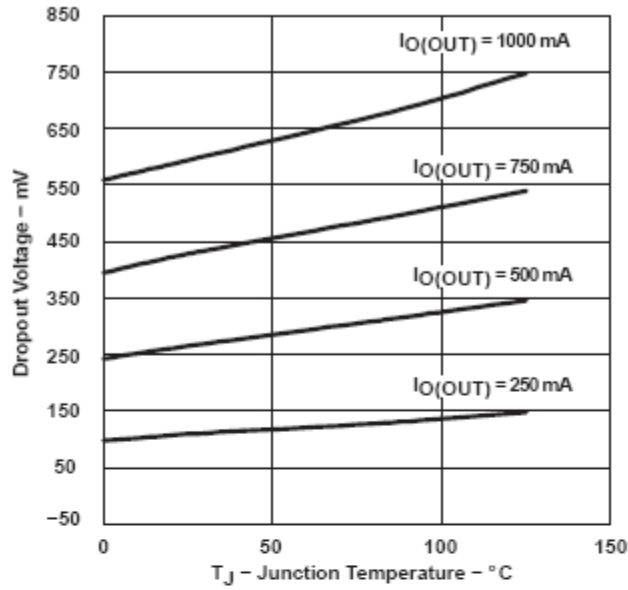

Figure 1

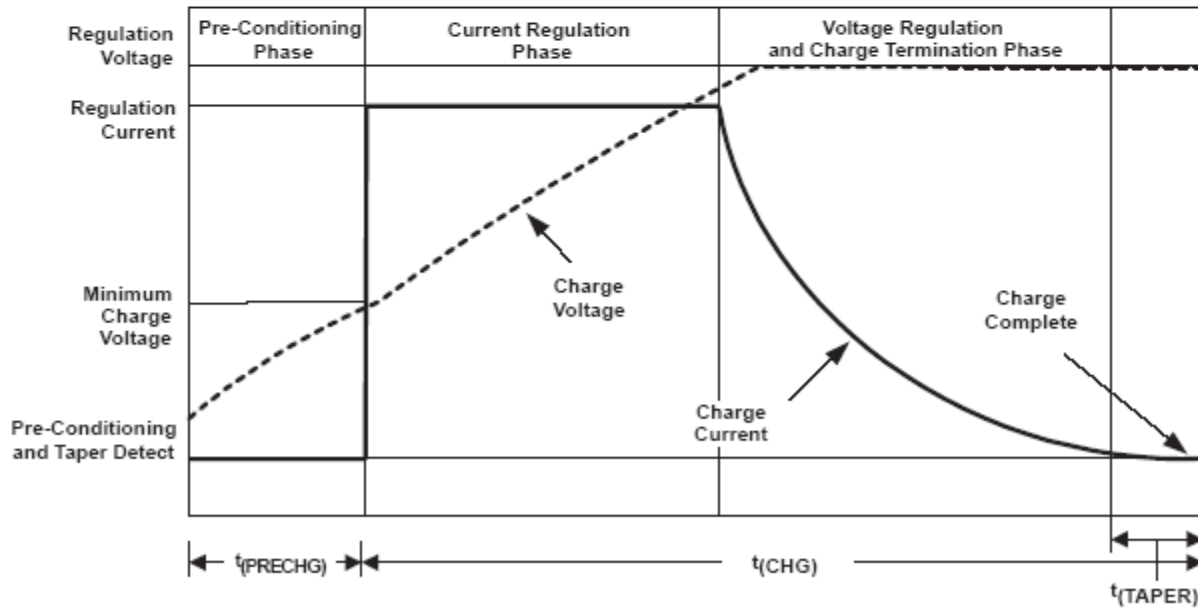

Figure 2. Typical Charging Profile



Application Information

The LP28056S is a single cell lithium-ion battery charger using a constant-current/constant-voltage algorithm. It can deliver up to 1200mA of charge current (using a good thermal PCB layout) with a final float voltage accuracy of 4.2V. The LP28056S includes an internal P-channel power MOSFET and thermal regulation circuitry. No blocking diode or external current sense resistor is required; thus, the basic charger circuit requires only two external components. Furthermore, the LP28056S is capable of operating from a USB power source.

Normal Charge Cycle

A charge cycle begins when the voltage at the VIN pin rises above the UVLO threshold level and a 1% ISET ram resistor is connected from the ISET pin to ground or when a battery is connected to the charger output. If the BAT pin is less than 2.9V, the charger enters trickle charge mode. In this mode, the LP28056S supplies approximately 1/10 the R_{ISET} rammed charge current to bring the battery voltage up to a safe level for full current charging.

When the BAT pin voltage rises above 2.9V, the charger enters constant-current mode, where the R_{ISET} rammed charge current is supplied to the battery. When the BAT pin approaches the final float voltage, the LP28056S enters constant-voltage mode and the charge current begins to decrease. The charge cycle ends when the charge current drops to 1/10 of the R_{ISET} rammed value.

ISET ramming Charge Current

The charge current is R_{ISET} rammed using a single resistor from the ISET pin to ground. The battery charge current is 500 times the current out of the

ISET pin. The ISET ram resistor and the charge current are calculated using the following equations:

$$R_{ISET}=1000V/I_{CHG}, I_{BAT}=1000V/R_{ISET}$$

The charge current out of the BAT pin can be determined at any time by monitoring the ISET pin voltage using the following equation:

$$I_{BAT}=V_{ISET}\times 500/R_{ISET}$$

Note: V_{ISET} is 2Volts.

Charge Termination

A charge cycle is terminated when the charge current falls to 1/10th the I_{SET} rammed value after the final float voltage is reached. This condition is detected by using an internal, filtered comparator to monitor the ISET pin. When the ISET pin voltage falls below 200mV for longer than t_{TERM}(typically 1ms), charging is terminated. The charge current is latched off and the LP28056S enters standby mode, where the input supply current drops to 200µA. In this state, all loads on the BAT pin must be supplied by the battery. (Note: C/10 termination is disabled in trickle charging and thermal limiting modes).

Automatic Recharge

The LP28056S constantly monitors the BAT pin voltage in standby mode. If this voltage drops below the 4.05V recharge threshold (V_{RECHRG}), another charge cycle begins and current is once again supplied to the battery. To manually restart a charge cycle when in standby mode, the input voltage must be removed and reapplied.



Charge Status Indicator (STAT)

The charge status output has two different states: strong pull-down (~5mA) and high impedance. The strong pull-down state indicates that the LP28056S is in a charge cycle. Once the charge cycle has terminated, the pin state is determined by under voltage lockout conditions. High impedance indicates that the LP28056S is in under voltage lockout mode: either V_{IN} is less than 100mV above the BAT pin voltage or insufficient voltage is applied to the VIN pin. A microprocessor can be used to distinguish between these two states.

Charge Stage	STAT1 Status	STAT2 Status
Charging	Low	High
Charge Complete	High	Low

Thermal Limiting

An internal thermal feedback loop reduces the I_{SET} rammed charge current if the die temperature attempts to rise above a preset value of approximately 150°C. This feature protects the LP28056S from excessive temperature and allows the user to push the limits of the power handling capability of a given circuit board without risk of damaging the LP28056S. The charge current can be set according to typical (not worst-case) ambient temperature with the assurance that the charger will automatically reduce the current in worst-case conditions.

Under voltage Lockout (UVLO)

An internal under voltage lockout circuit monitors the input voltage and keeps the charger in shutdown mode until V_{IN} rises above the under voltage lockout threshold. The UVLO circuit has a built-in hysteresis of 200mV. Furthermore, to protect against reverse current in the power MOSFET, the UVLO circuit keeps the charger in shutdown mode if V_{IN} falls to within 30mV of the battery voltage. If the UVLO comparator is tripped, the charger will not come out of shutdown mode until V_{IN} rises to 100mV above the battery voltage.

Power Dissipation

The conditions that cause the LP28056S to reduce charge current through thermal feedback can be approximated by considering the power dissipated in the IC. Nearly all of this power dissipation is generated by the internal MOSFET. This is calculated to be approximately:

$$P_D = (V_{IN} - V_{BAT}) \times I_{BAT}$$

Where P_D is the power dissipated, V_{IN} is the input supply voltage, V_{BAT} is the battery voltage and I_{BAT} is the charge current. The approximate ambient temperature at which the thermal feedback begins to protect the IC is:

$$T_A = 150^\circ\text{C} - P_D \times \theta_{JA}$$

$$T_A = 150^\circ\text{C} - (V_{IN} - V_{BAT}) \times I_{BAT} \times \theta_{JA}$$



Packaging Information

ESOP-8

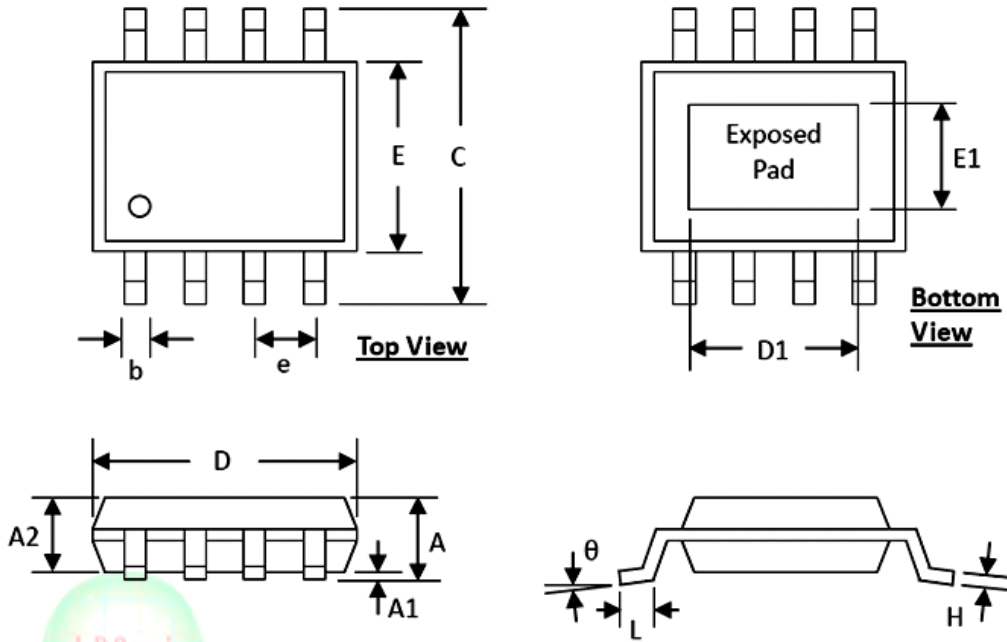

SYMBOLS	DIMENSION (MM)		DIMENSION (INCH)	
	MIN	MAX	MIN	MAX
A	1.30	1.70	0.051	0.067
A1	0.00	0.15	0.000	0.006
A2	1.25	1.52	0.049	0.060
b	0.33	0.51	0.013	0.020
C	5.80	6.20	0.228	0.244
D	4.80	5.00	0.189	0.197
D1	3.15	3.45	0.124	0.136
E	3.80	4.00	0.150	0.157
E1	2.26	2.56	0.089	0.101
e	1.27 BSC		0.050 BSC	
H	0.19	0.25	0.0075	0.0098
L	0.41	1.27	0.016	0.050
θ	0°	8°	0°	8°