



2 cell Li-ion Battery Charge from 3V~12V

General Description

The LP28400A is a complete constant-current/constant voltage switching charger for multi cell lithium-ion batteries. Boost+Linear charger work with a USB 2.0 compliant power IC assuring 2 cell Lilon battery charging. When the battery voltage is low, the charger works in linear operation mode. Along with the charging the battery voltage is higher the charger will transfer to Boost operation mode smoothly. When the battery voltage <6V, switch to wake-up current charging. Other features include charge current monitor, under voltage lockout, automatic recharge and a status pin to indicate charge termination.

Order Information

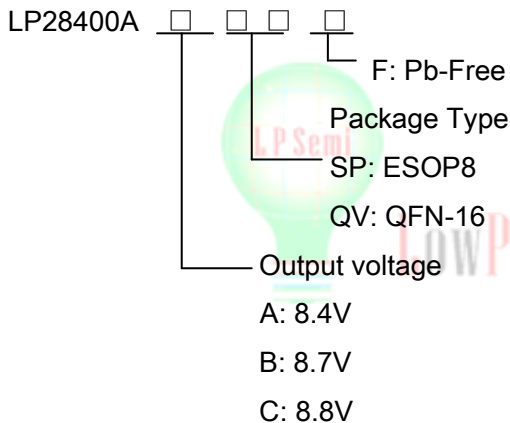

Applications

- ✧ 2 cell Li-Ion handheld devices
- ✧ POS device
- ✧ Bluetooth speaker
- ✧ USB powered devices

Features

- ◆ Adapter Adaptive
- ◆ Input voltage range 3V~12V
- ◆ Integrated low side power mosfet
- ◆ Simple structure and perfect transition between Linear and Boost operation
- ◆ Programmable charge current and CV voltage
- ◆ Dynamic input current allocation for maximum charging rate
- ◆ Automatically switches to wake-up current when charging over-discharged batteries
- ◆ Over Current Protection
- ◆ Over Temperature Protection
- ◆ Consumption Available in ESOP8 & QFN16(3mm*3mm) Package
- ◆ RoHS Compliant and 100% Lead (Pb)-Free
- ◆ Programmable Charge Mode for 2cells,3cells or 4cells charging (QFN-16 package only)

Marking Information

Device	Marking	Package	Shipping
LP28400AASPF	LPS	ESOP8	3K/REEL
LP28400AAQVF	LP28400AA YWX	QFN-16	
LP28400ABSPF	LPS	ESOP8	3K/REEL
LP28400ABQVF	LP28400AB YWX	QFN-16	
LP28400ACSPF	LPS	ESOP8	3K/REEL
LP28400ACQVF	LP28400AC YWX	QFN-16	
Marking indication: Y:Production year W:Production week X:Series Number			



Functional Pin Description

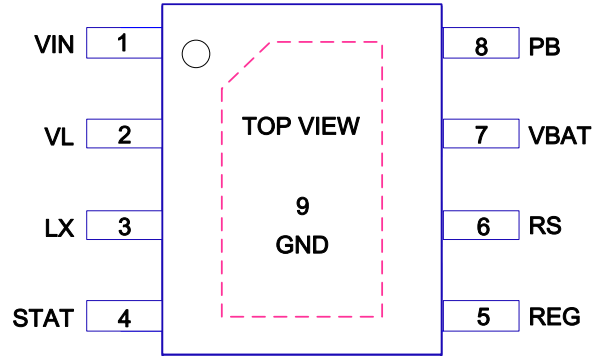
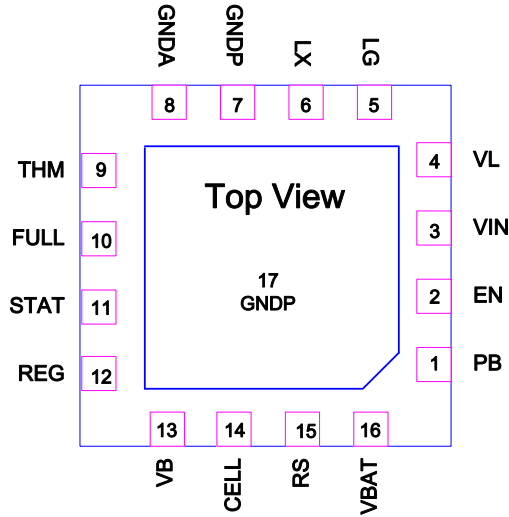

Pin Description

QFN-16	ESOP8	Pin Name	I/O	Description
1	8	PB	O	Gate control signal for pass transistor also the compensation for Boost.
2		EN	I	Enable pin, active high.
3	1	VIN	I	Power input.
4	2	VL	O	Internal LDO output. Connect a decoupling 4.7uF capacitor to GNDP.
5		LG	O	Low side gate driver for outside power mosfet.
6	3	LX	P	Switching Node Connection.
7,17	9	GNDP	P	Ground for Power section.
8		GND	P	Ground for the analog circuits.
9		THM	I	Thermistor input. If $V_{THM} < 0.28 * V(VL)$ the charging is inhibited. If $0.28 * V(VL) < V_{THM} < 0.74 * V(VL)$ the charger operates normally. If $V_{THM} > 0.74 * V(VL)$ the charging is inhibited.
10		FULL	O	Battery full indication pin, active low.
11	4	STAT	O	Indicates charge status. Active low when charging is on.
12	5	REG	I	Input voltage feedback for the input voltage regulation loop.
13		VB	I	Programmable battery-full voltage. Connect to GND for 4.4V, leave floating to 4.2V, and connect to VL for 4.35V
14		CELLS	I	Cell selection. Connect to GND for 3 cells, leave floating to 2 cells, and connect to VL for 4 cells.
15	6	RS	I	Indicates charging terminated.
16	7	VBAT	I	Sense pin for battery voltage.



Typical Application Circuit

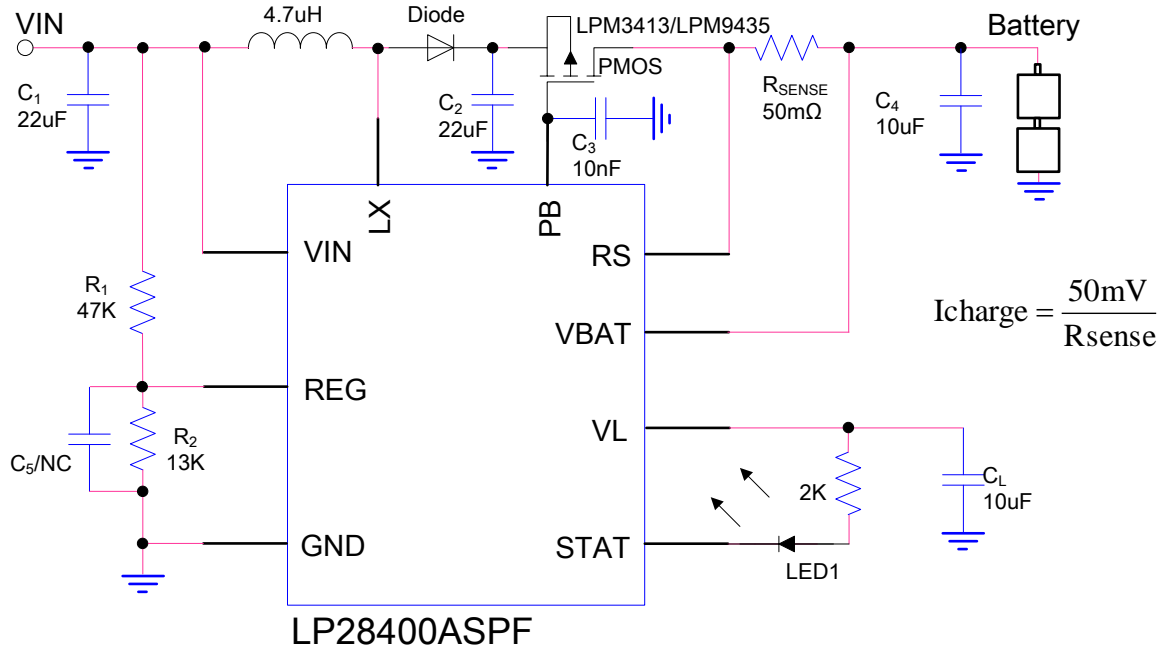

LP28400ASPF Application for 2 cells battery form 3V~12V

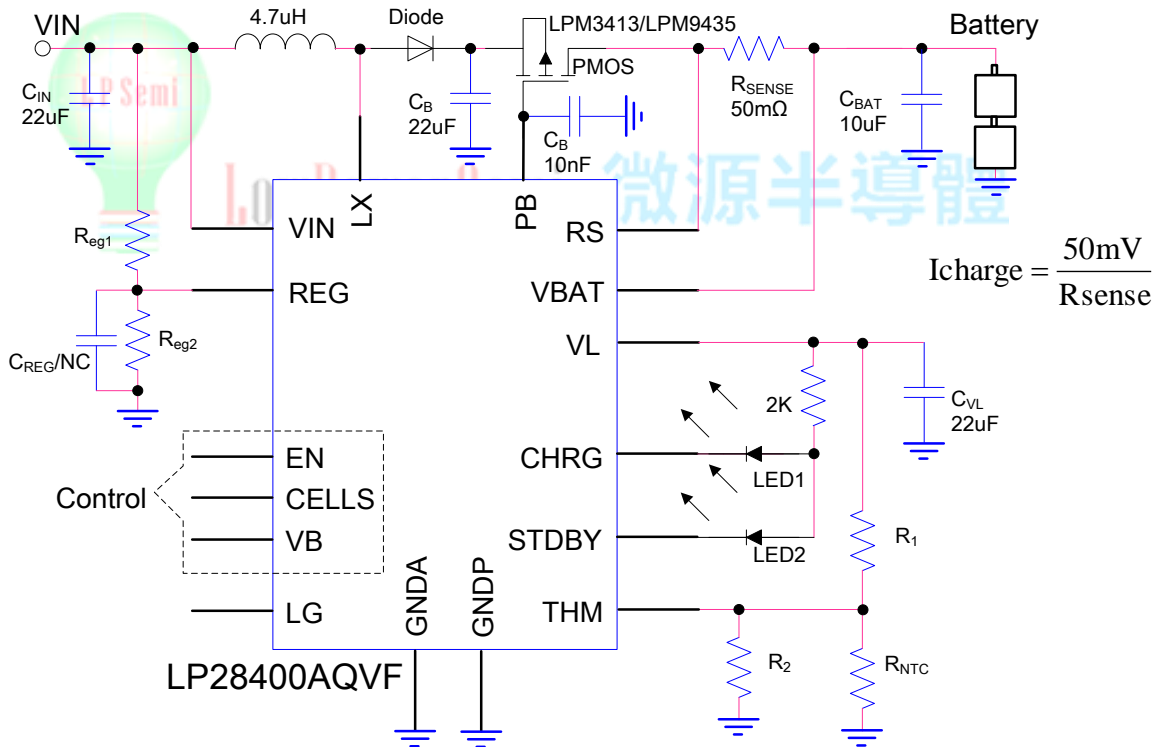

LP28400AQVF Application for 2~4 cells battery

NOTE: The capacitor CVL must put away form LX pin.



Absolute Maximum Ratings ^{Note 1}

- ◇ VIN,LX, RS,VBAT,PB to GND -----0.3V to 18V
- ◇ VL to GND ----- -0.3V to 6V
- ◇ REG,STAT to GND ----- -0.3V to VL+0.3V
- ◇ Maximum Junction Temperature ----- 150°C
- ◇ Operating Junction Temperature Range (TJ) ----- -40°C to 85°C
- ◇ Maximum Soldering Temperature (at leads, 10 sec) ----- 260°C

Note 1. Stresses beyond those listed under “Absolute Maximum Ratings” may cause permanent damage to the device. These are stress ratings only, and functional operation of the device at these or any other conditions beyond those indicated in the operational sections of the specifications is not implied. Exposure to absolute maximum rating conditions for extended periods may affect device reliability.

Thermal Information

- ◇ Maximum Power Dissipation (ESOP8, PD,TA=25°C) ----- 2.0W
- ◇ Thermal Resistance (ESOP8,JA) ----- 46°C/W

ESD Susceptibility

- ◇ HBM(Human Body Mode) ^{Note 2} ----- 2KV
- ◇ MM(Machine Mode) ^{Note 3} ----- 200V

Note 2. The Human body model (HBM) is a 100pF capacitor discharged through a 1.5kΩ resistor into each pin. The testing is done according JEDEC.

Note 3. Machine Model (MM) is a 200pF capacitor discharged through a 500nH inductor with no series resistor into each pin. The testing is done according JEDEC.



Electrical Characteristics

(T_A = 25°C. unless otherwise noted.)

Parameter	Test Conditions	Measured	Limits			Units
			Min	Typ	Max	
Quiescent current		I _Q		1		mA
Internal LDO output	V _{IN} =6V	V(VL)	4.9	5	5.1	V
Input voltage regulation reference		V _{REG}	0.95	1	1.05	V
Battery leakage current	V _{BAT} =8.4V, V _{IN} =NC	I _{BAT}			-10	uA
	V _{BAT} =8.4V, V _{IN} =5V				-35	
Program Charging Current	From R _s to V _{BAT}	V(R _S ,V _{BAT})	47.5	50	52.5	mV
Charge current limit	V _{IN} =5V	I _{BATLIMIT}		1.5		A
CV voltage		V(V _{BAT})		8.4		V
Recharge threshold		V(V _{BAT})		300		mV
End of charge threshold	From R _s to V _{BAT}	V(R _S ,V _{BAT})		5		mV
Trickle charge voltage threshold		V(V _{BAT})		6		V
Trickle charge current	From R _s to V _{BAT}	V(R _S ,V _{BAT})		10		mV
Thermal protection	Not tested in production		135	145	155	°C
Switching frequency		LX		1		MHz
UVLO input voltage Threshold	V _{IN} increasing	V _{IN}	-	2.65	-	V
UVLO Hysteresis	V _{IN} decaying	V _{IN}	-	150	-	mV
STAT low level	Open drain pulled up with 5mA	STAT			0.2	V
Low side R _{dson}	From LX to GND	R(LX,GND)		60		mΩ
THM threshold, Hot		V _{THM-L}		0.28*V(VL)		V
THM threshold, Cold		V _{THM-H}		0.74*V(VL)		

Note: Charge current set by: $I_{BAT} = \frac{V_{RSENSE}}{R_{SENSE}}$



Typical Operating Characteristic

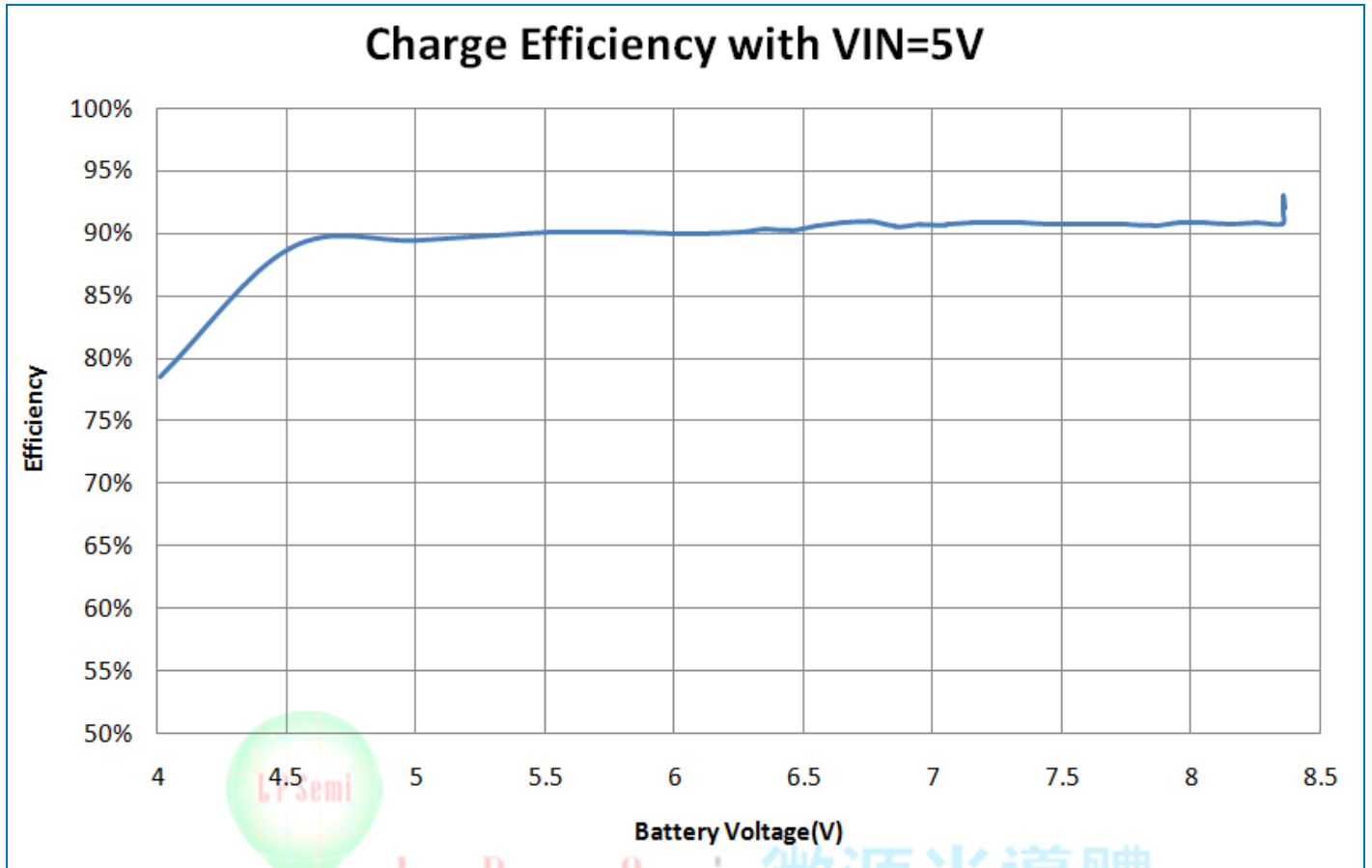



Function Description

LP28400A is a wide range VIN(3V-12V), 1.5A two-cell asynchronous boost Li-Ion battery charger integrates 1MHz switching frequency and full protection functions. The charge current up to 1.5A can be programmed by using the external resistor for different portable applications and indicates the charger current information simultaneous.

It also has an adaptive input current limit for safety battery charge operation. It consists of 18V rating FETs with extremely low ON resistance to achieve high charge efficiency and simple peripheral circuit design.

Battery Charge Mode

If the plug in input voltage VIN is higher than VBAT, the switching block will stop work to keep LX pin in high resistance and PB will control the external PMOS` VGS to match the battery voltage. Under this condition, the Boost charger function stops work and regulates the external FET works in linear charge mode. Whether the circuit work in Boost mode or Linear mode, the constant charge current is programmed by Rsense with:

$$I_{BAT} = \frac{V_{RSENSE}}{R_{SENSE}}$$

Which VRSENSE=50mV

The circuit would work in trickle charge mode when battery voltage below 6V with VRSENSE=10mV. The terminal charge current would be programmed by VRSENSE=5mV.

During the charging mode, constant (trickle) charging current loop is active first. When VBAT equals to constant voltage threshold, constant voltage loop takes over and pull down the charging current. When IBAT is lower than the termination current threshold ITERM, the main FET of boost charger is turned off firstly. External PMOS are turned off when the current is down to zero. Then, LP28400A is waiting for recharge mode.

Input Source Qualification

After REGN amplifier powers up, the LP28400A checks the current capability of the input source. The input source has to meet the VREG>1V to enable the chip.

Number of Charge Cell Selection (QFN-16)

The number of charge cell can be programmed by changing the connection of CELLS Pin (QFN-16 package only). Connect CELLS Pin to GND is provide for 3 cells charging, leave floating for 2 cells, and connect to VL for 4 cells.

CELLS Pin Connected	Charge Cells
Floating(No connected)	2
GND	3
VL	4



Battery Temperature Detection

The LP28400A continuously monitors temperature by measuring the voltage between the THM and GND pins. A negative or a positive temperature coefficient thermistor (NTC, PTC) and an external voltage divider typically develop this voltage. The LP28400A compares this voltage against its internal VTHM-L and VTHM-H thresholds to determine if charging is allowed. The temperature sensing circuit is immune to any fluctuation in V_{VL}, since both the external voltage divider and the internal thresholds (VTHM-L)and VTHM-H) are referenced to V_{VL}.

The resistor values of R1 and R2 are calculated by the following equations:

For NTC Thermistors

$$R_1 = \frac{R_{TL}R_{TH}(K_2 - K_1)}{(R_{TL} - R_{TH})K_1K_2}$$

$$R_2 = \frac{R_{TL}R_{TH}(K_2 - K_1)}{R_{TL}(K_1 - K_1K_2) - R_{TH}(K_2 - K_1K_2)}$$

For PTC Thermistors

$$R_1 = \frac{R_{TL}R_{TH}(K_2 - K_1)}{(R_{TH} - R_{TL})K_1K_2}$$

$$R_2 = \frac{R_{TL}R_{TH}(K_2 - K_1)}{R_{TH}(K_1 - K_1K_2) - R_{TL}(K_2 - K_1K_2)}$$

K1(VTHM-L)=28% , K2(VTHM-H)=74%.

Where R(TC) is the cold temperature resistance and R(TH) is the hot temperature resistance of thermistor, as specified by the thermistor manufacturer. R1 or R2 can be omitted if only one temperature (hot or cold) setting is required. Applying a voltage between the VTHM-L and VTHM-H thresholds to pin THM disables the temperature-sensing feature.

Charge state indication

As showed below, the LED STAT respond to this five STATES.

STATE	STAT Pin	LED STAT
Without Battery	Flicker	Flicker
Charging	Low	Light On
Charge complete	High	Light Off
Vreg < Vreg(th)	Low	Light On



Packaging Information

ESOP8

SOP-8 (FD)

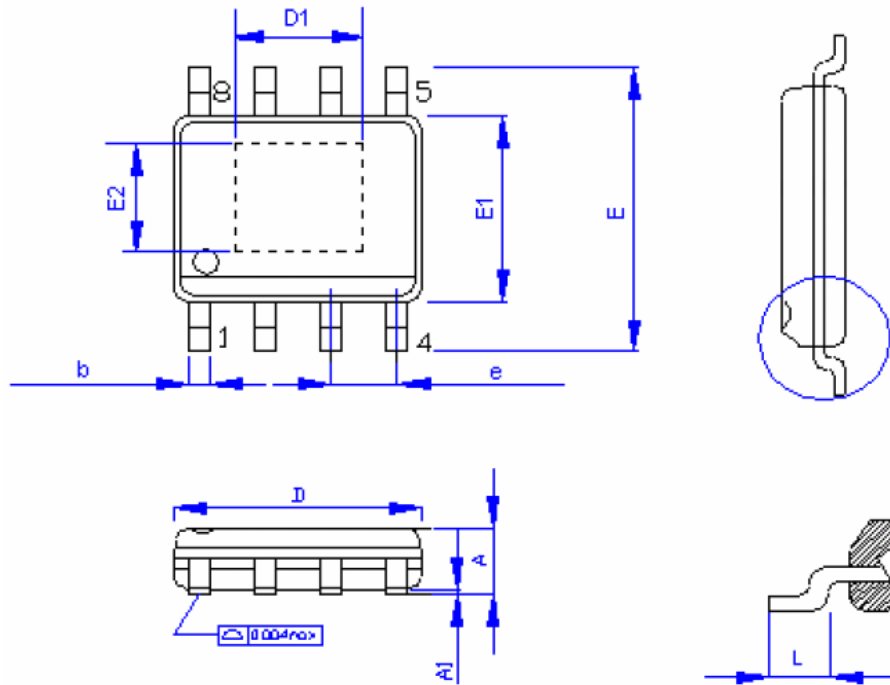

SYMBOLS	MILLIMETERS		INCHES	
	MIN.	MAX.	MIN.	MAX.
A	1.35	1.75	0.053	0.069
A1	0.05	0.25	0.002	0.010
D	4.90		0.193	
E1	3.90		0.153	
E	5.80	6.20	0.228	0.244
L	0.40	1.27	0.016	0.050
b	0.33	0.51	0.013	0.020
e	1.27		0.500	
D1	2.06		0.081	
E2	2.06		0.081	



QFN-16

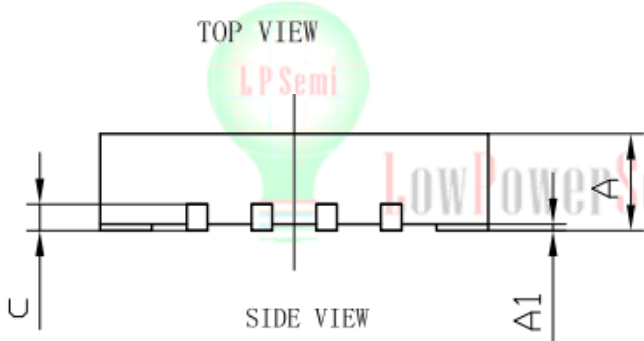
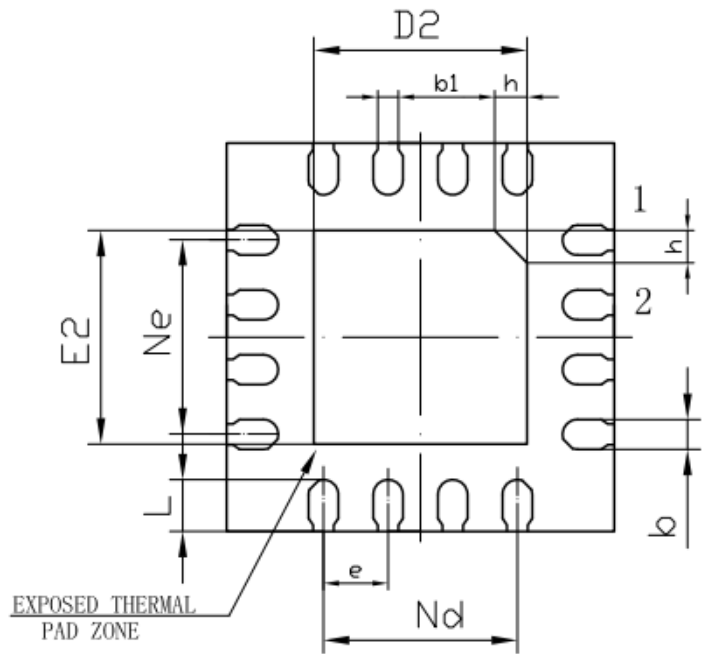
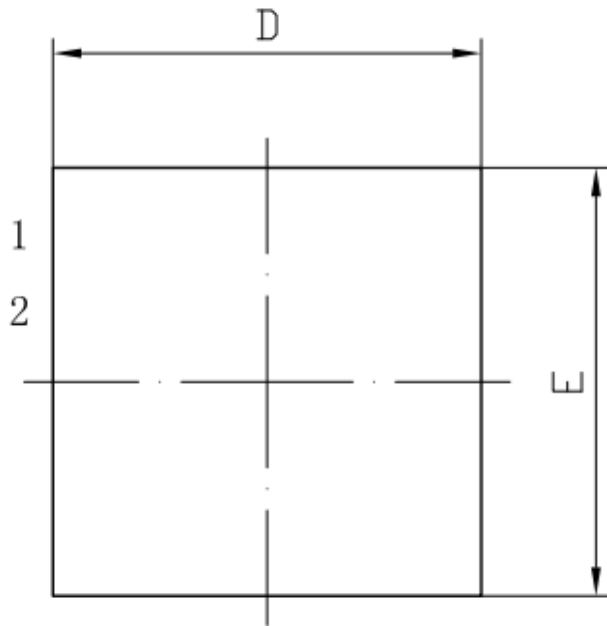

BOTTOM VIEW

SYMBOL	MILLIMETER		
	MIN	NOM	MAX
A	0.70	0.75	0.80
A1	0	0.02	0.05
b	0.18	0.25	0.30
b1	0.16REF		
c	0.18	0.20	0.25
D	2.90	3.00	3.10
D2	1.55	1.65	1.75
e	0.50BSC		
Ne	1.50BSC		
Nd	1.50BSC		
E	2.90	3.00	3.10
E2	1.55	1.65	1.75
L	0.35	0.40	0.45
h	0.20	0.25	0.30