

Model Name :

**LP315T0 Open-Cell Product
Tentative Specification**

The Information Described in the Specification is Preliminary and can be changed
Without Prior notice.

ACCEPTED BY :

APPROVED BY	CHECKED BY	PREPARED BY

Prepared by : Design General Division

Check by : Marketing & Sales Division

CEC PANDA LCD Tech Co., Ltd

19FL, CEC Mansion, No.37 Jianning Rd, XiaGuan district, Nanjing, Jiangsu
TEL: +86-25-58595158 FAX: +86-25-58595178

Doc. No:	LP315T0- Tentative	Issue Date:	2011/05/03
----------	--------------------	-------------	------------

RECORD OF REVISIONS

Revision	Date	Page	Description
Ver1.0	2011/05/03	all	tentative specification was first issued .

CONTENTS

No	Item	Page
1	Application	4
2	Overview	4
3	Mechanical Technical literatures	5
4	Pixel array and member location	5
5	Input Terminals	6
6	Electrical Characteristics	10
7	Timing characteristics of input signals	12
8	Input Signal, Basic Display Colors and Gray Scale of Each Color	13
9	Optical characteristics	14
10	Handling Precautions of the Open-cell	16
11	Packing form	17
12	Reliability test item	17
13	Others	18
14	Carton Storage condition	18
15	Precautions	18

1. Application

This technical literature applies to the color 31.5" Wide XGA TFT-LCD LM315TA-T01

- * These specification sheets are proprietary products of Nanjing CEC-Panda LCD Technology Co., LTD ("CPL") and include materials protected under copyright of CPL. Do not reproduce or cause any third party to reproduce them in any form or by any means, electronic or mechanical, for any purpose, in whole or in part, without the express written permission of CPL.
- * This module is not designed to use in dusty environment and to prevent image retention caused by long-term display of fixed pattern. So please consider items mentioned above before use and design equipment.
- * In case of using the device for applications such as control and safety equipment for transportation (aircraft, trains, automobiles, etc.), rescue and security equipment and various safety related equipment which require higher reliability and safety, take into consideration that appropriate measures such as fail-safe functions and redundant system design should be taken.
- * Do not use the device for equipment that requires an extreme level of reliability, such as aerospace applications, telecommunication equipment (trunk lines), nuclear power control equipment and medical or other equipment for life support.
- * CPL assumes no responsibility for any damage resulting from the use of the device that does not comply with the instructions and the precautions specified in these technical literature.
- * Contact and consult with a CPL sales representative for any questions about this device.

2. Overview

This module is color active matrix LCD Open-cell incorporating amorphous silicon TFT (Thin Film Transistor). It is composed of a color TFT-LCD panel, driver ICs, etc. Graphics and texts can be displayed on a 1366×RGB×768 dots panel with about 16,777,216 colors(R/G/B 8bit in each color) by using LVDS(Low Voltage Differential Signaling) to interface, +12V of DC supply voltage.

In order to improve the response time of LCD, this module applies the Over Shoot driving (O/S driving) technology for the control circuit. In the O/S driving technology, signals are being applied to the Liquid Crystal according to a pre-fixed process as an image signal of the present frame when a difference is found between image signal of the previous frame and that of the current frame after comparing them.

By using the captioned process, the image signals of this LCD module are being set so that image response can be completed within one frame, as a result, image blur can be improved and clear image performance can be realized.

3. Mechanical Technical literatures

Parameter	Technical literatures	Unit
Display size	80.039 (Diagonal)	cm
	31.5 (Diagonal)	inch
Active area	697.685(H) x 392.256(V)	mm
Pixel Format	1366(H) x 768(V) (1pixel = R+G+B)	pixel
Pixel pitch	0.51075(H) x 0.51075 (V)	mm
Pixel configuration	R, G, B vertical stripe	
Display mode	Normally black	
Unit Outline Dimensions (*1)	715.7(W) x456.05(H) x 1.74(D)	mm
Mass	1.15±0.1	kg
Surface treatment(*2)	Anti glare Hard coating: (2H)	

(*1) Outline dimensions are shown in Fig. Outline Dimensions

(*2) This specification is without the protection film.

4. Pixel array and member location

Pixel array and member located as below.

There are 6 Source Drivers (684 input terminals S-Dr) on this panel.

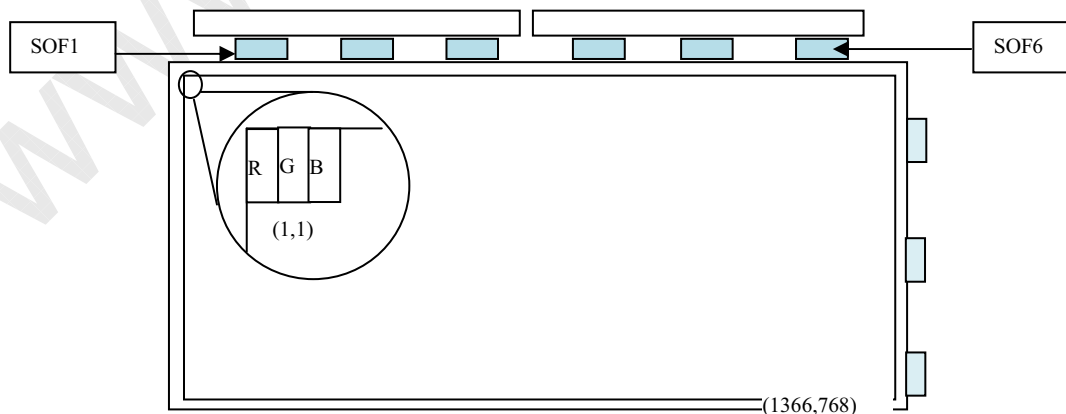

5. Input Terminals

5-1 TFT panel driving

CN1 (Interface signals and +12V DC power supply) Shown on the next table.

Using connector: FI-X30SSL-HF-R2500 (Japan Aviation Electronics Ind., Ltd)

Matching connector: FI-X30H/FI-X30HL, FI-X30C/FI-X30C2L, or FIX30M

(Japan Aviation Electronics Ind., Ltd)

Matching LVDS transmitter: THC63LVDM83R (THine) or equivalent device

Pin No.	Symbol	Function	Remark
1	VCC	+12V Power Supply	
2	VCC	+12V Power Supply	
3	VCC	+12V Power Supply	
4	VCC	+12V Power Supply	
5	GND	Ground	
6	GND	Ground	
7	GND	Ground	
8	GND	Ground	
9	SELLVDS	Select LVDS data order[Note1]	Default: pull down (L:GND) [Note2]
10	Reserved	Not Available	
11	GND	Ground	
12	RIN0-	Negative(-) LVDS differential data input	LVDS
13	RIN0+	Positive(+) LVDS differential data input	LVDS
14	GND	Ground	
15	RIN1-	Negative(-) LVDS differential data input	LVDS
16	RIN1+	Positive(+) LVDS differential data input	LVDS
17	GND	Ground	
18	RIN2-	Negative(-) LVDS differential data input	LVDS
19	RIN2+	Positive(+) LVDS differential data input	LVDS
20	GND	Ground	
21	CLKIN-	Clock Signal(-)	LVDS
22	CLKIN+	Clock Signal(+)	LVDS
23	GND	Ground	
24	RIN3-	Negative(-) LVDS differential data input	LVDS
25	RIN3+	Positive(+) LVDS differential data input	LVDS
26	GND	Ground	
27	Reserved	Not Available	
28	Reserved	Not Available	
29	GND	Ground	
30	GND	Ground	

5-2 SELLVDS

Transmitter		SELLVDS	
Pin No	Data	= L(GND) or Open	=H(3.3V)
51	TA0	R0(LSB)	R2
52	TA1	R1	R3
54	TA2	R2	R4
55	TA3	R3	R5
56	TA4	R4	R6
3	TA5	R5	R7(MSB)
4	TA6	G0(LSB)	G2
6	TB0	G1	G3
7	TB1	G2	G4
11	TB2	G3	G5
12	TB3	G4	G6
14	TB4	G5	G7(MSB)
15	TB5	B0(LSB)	B2
19	TB6	B1	B3
20	TC0	B2	B4
22	TC1	B3	B5
23	TC2	B4	B6
24	TC3	B5	B7(MSB)
27	TC4	NA	NA
28	TC5	NA	NA
30	TC6	DE(*)	DE(*)
50	TD0	R6	R0(LSB)
2	TD1	R7(MSB)	R1
8	TD2	G6	G0(LSB)
10	TD3	G7(MSB)	G1
16	TD4	B6	B0(LSB)
18	TD5	B7(MSB)	B1
25	TD6	NA	NA

NA: Not Available

(*)The display position is prescribed by the rise of DE (Display Enable) signal, please do not fix DE signal during operation at "High."

[Note 2] The equivalent circuit figure of the terminal

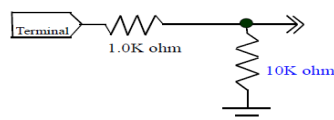

PANDA

2011-5-3

5-3 Interface block diagram

Corresponding Transmitter: Corresponding Transmitter: THC63LVDM83R (THine) or equivalent device.

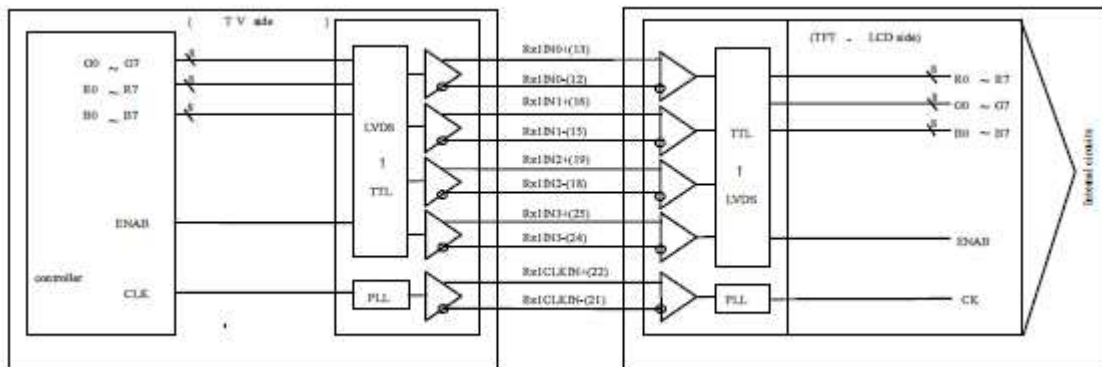

5-4 Block Diagram (Open-cell)

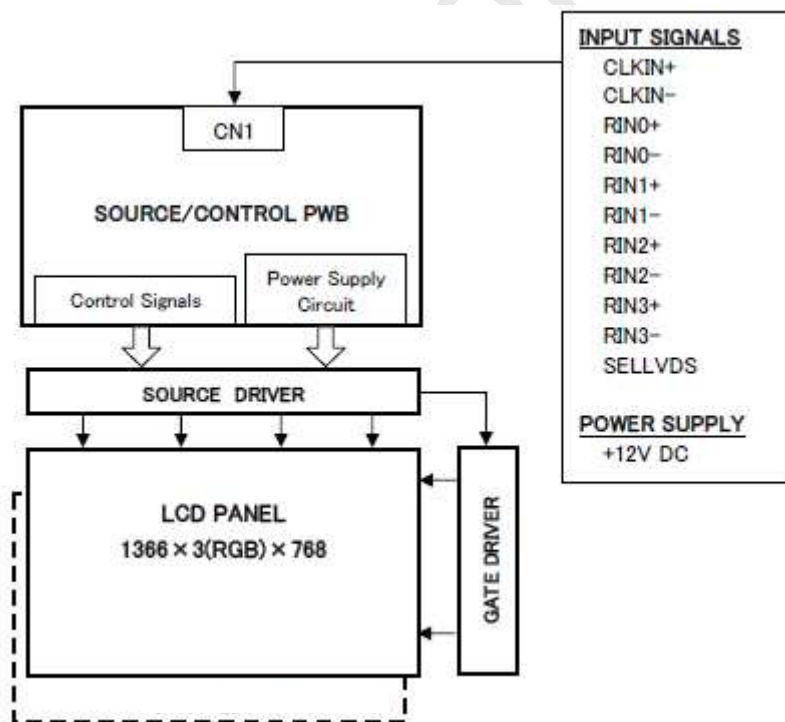

SELLVDS= High (3.3V)

PANDA

2011-5-3

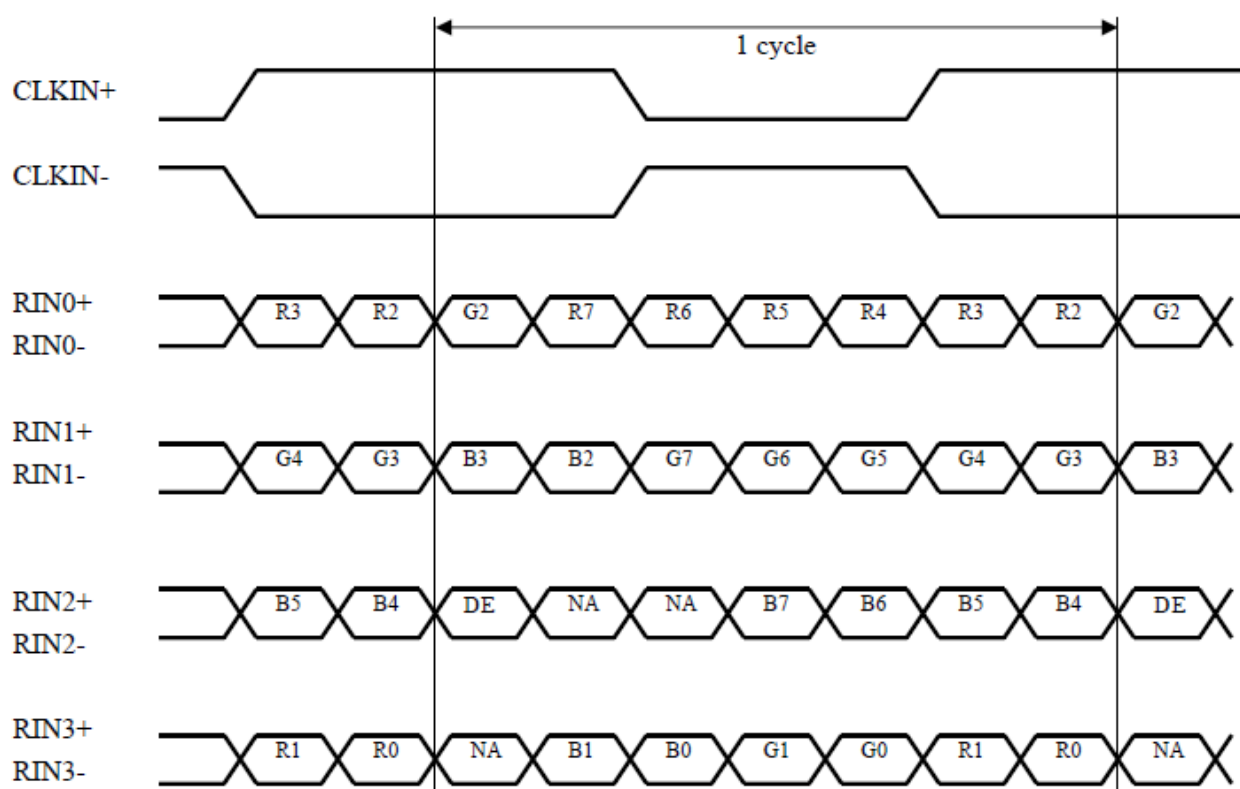

SELLVDS= LOW (GND) or OPEN

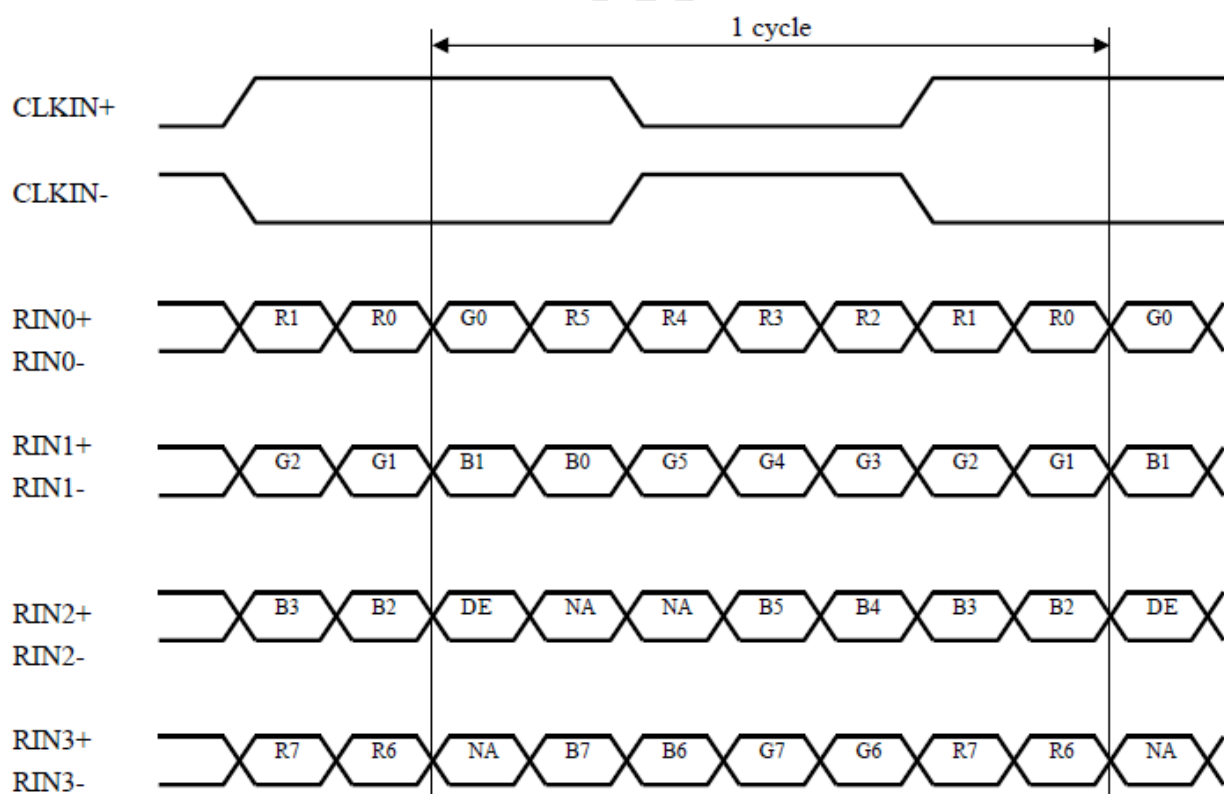

DE: Display Enable

NA: Not Available (Fixed Low)

6. Electrical Characteristics

6-1 Absolute Maximum Rating

Parameter	Symbol	Condition	Ratings	Unit	Remark
Input voltage	V_I	$T_a=25^\circ\text{C}$	-0.3 ~ 3.6	V	[Note 1]
+12V supply voltage (for Control)	V_{CC}	$T_a=25^\circ\text{C}$	0 ~ +15	V	
Storage temperature	T_{stg}	-	-25 ~ +60	$^\circ\text{C}$	
Operation temperature	T_{opa}	-	0 ~ +50	$^\circ\text{C}$	

[Note 1] SELLVDS

6-2 Control circuit driving

Parameter		Symbol	Min.	Typ.	Max.	Unit	Remark
+12V supply voltage	Supply voltage	VCC	TBD	+12.0	TBD	V	[Note 1]
	Current dissipation	ICC	-	TBD	TBD	mA	[Note 2]
		IRUSH	-	TBD	TBD	mA	[Note 5]
		TRUSH	-	TBD	-	ms	[Note 5]
Permissible input ripple voltage		VRP	-	-	100	mVP-P	$V_{CC} = +12.0\text{V}$
Differential input threshold voltage	High	VTH	-	-	100	mV	$V_{CM} = +1.2\text{V}$ [Note 4]
	Low	VTL	-100	-	-	mV	
Input Low voltage		VIL	0	-	TBD	V	[Note 3]
Input High voltage		VIH	TBD	-	TBD	V	
Input leak current (Low)		IIL	-	-	TBD	μA	$V_I = 0\text{V}$ [Note 3]
Input leak current (High)		IIH	-	-	TBD	μA	$V_I = 3.3\text{V}$ [Note 3]

[VCM]: Common mode voltage of LVDS driver

[Note 1] Input voltage sequences

Dip conditions for supply voltage

TBD

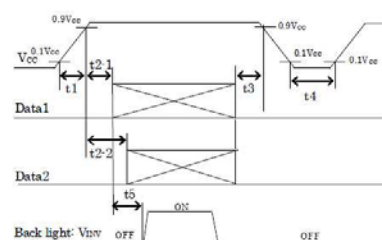

TBD

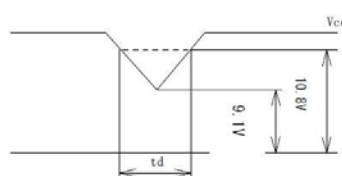

※ Data1: CLKIN \pm , RIN0 \pm , RIN1 \pm , RIN2 \pm , RIN3 \pm

PANDA

2011-5-3

※ Data2: SELLVDS

※ About the relation between data input and back light lighting, please base on the above-mentioned input sequence.

When back light is switched on before panel operation or after a panel operation stop, it may not display normally. But this phenomenon is not based on change of an incoming signal, and does not give damage to a liquid crystal display.

[Note 2] Typical current situation: 256 gray-bar pattern (VCC = +12.0V).

The explanation of RGB gray scale is seen in section 8.

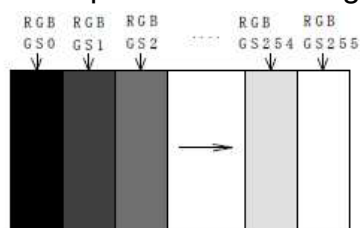

[Note 3] SELLVDS

[Note 4] CLKIN+/CLKIN-, RIN0+/RIN0-, RIN1+/RIN1-, RIN2+/RIN2-, RIN3+/RIN3-

[Note 5] The Rush current corrugation at the time of power on.

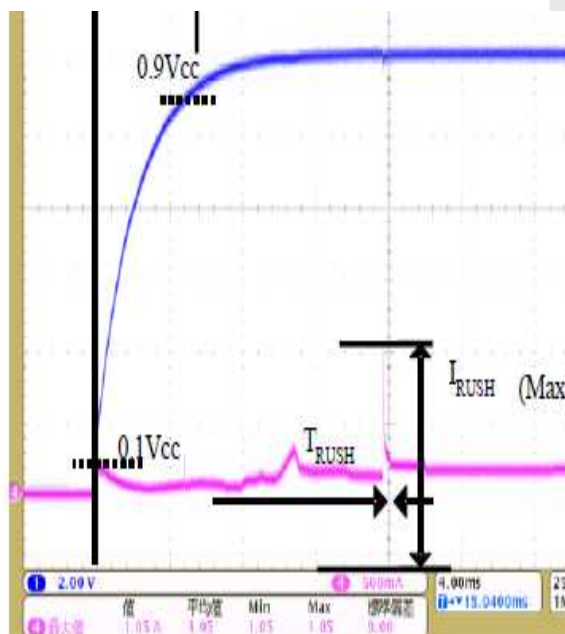

Ton: Vcc(+12V) Rising Time
From 10%Vcc to 90%Vcc
I: Current of Vcc(+12V)
I_{RUSH}: The max current
After Vcc rose.
T_{Rush}: The length of the I_{Rush} peak

[HOW TO]

Measure the Vcc(12V) when you turn the power on. At the same time, measure the current of Vcc(12V).

The single mode of the oscilloscope is useful in this case.

***After the measurement, Please replace the picture (left) with the Measurement.**

7. Timing characteristics of input signals

7-1 Timing Characteristics

Timing diagrams of input signal are shown in Fig.2

Parameter		Symbol	Min	Typ.		Max.	Unit
				NTSC	PAL		
Clock	Frequency	$1/T_c$	TBD	82	82	TBD	MHz
Data enable signal	Horizontal period	TH	TBD	1696	1696	TBD	clock
			TBD	20.68	20.68	TBD	μ s
	Horizontal period (High)	THd	TBD	1366	1366	TBD	clock
	Vertical period	TV	TBD	806	967	TBD	line
	Vertical period (High)	TVd	TBD	768	768	TBD	line

[Note]

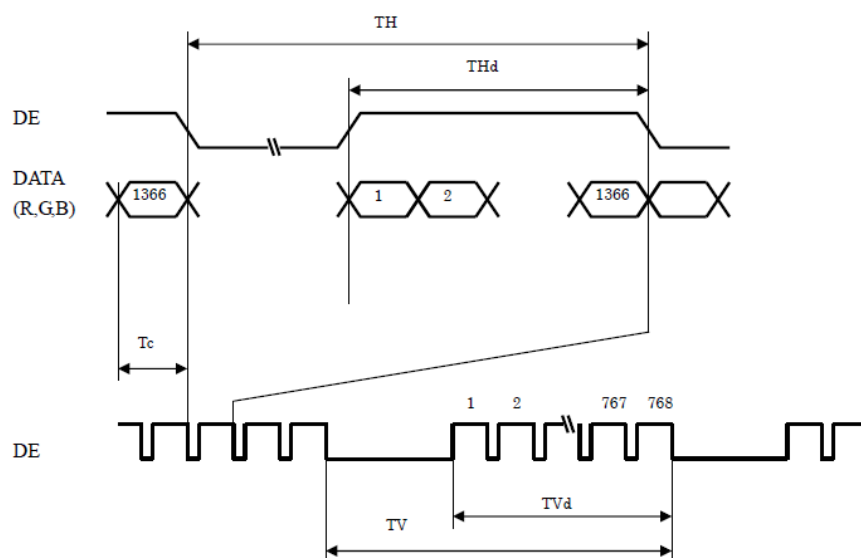

Fig.2 Timing characteristics of input signals

8. Input Signal, Basic Display Colors and Gray Scale of Each Color

Colors & Gray scale	Data signal																									
	Gray Scale	R0	R1	R2	R3	R4	R5	R6	R7	G0	G1	G2	G3	G4	G5	G6	G7	B0	B1	B2	B3	B4	B5	B6	B7	
Basic Color	Black	—	0	0	0	0	0	0	0	0	0	0	0	0	0	0	0	0	0	0	0	0	0	0	0	
	Blue	—	0	0	0	0	0	0	0	0	0	0	0	0	0	0	0	0	1	1	1	1	1	1	1	1
	Green	—	0	0	0	0	0	0	0	0	1	1	1	1	1	1	1	1	0	0	0	0	0	0	0	0
	Cyan	—	0	0	0	0	0	0	0	0	1	1	1	1	1	1	1	1	1	1	1	1	1	1	1	1
	Red	—	1	1	1	1	1	1	1	1	0	0	0	0	0	0	0	0	0	0	0	0	0	0	0	0
	Magenta	—	1	1	1	1	1	1	1	1	0	0	0	0	0	0	0	0	1	1	1	1	1	1	1	1
	Yellow	—	1	1	1	1	1	1	1	1	1	1	1	1	1	1	1	1	0	0	0	0	0	0	0	0
	White	—	1	1	1	1	1	1	1	1	1	1	1	1	1	1	1	1	1	1	1	1	1	1	1	1
Gray Scale of Red	Black	GS0	0	0	0	0	0	0	0	0	0	0	0	0	0	0	0	0	0	0	0	0	0	0	0	
	↑	GS1	1	0	0	0	0	0	0	0	0	0	0	0	0	0	0	0	0	0	0	0	0	0	0	
	Darker	GS2	0	1	0	0	0	0	0	0	0	0	0	0	0	0	0	0	0	0	0	0	0	0	0	
	↑	↓				↓							↓									↓				
	↓	↓				↓							↓									↓				
	Brighter	GS253	1	0	1	1	1	1	1	1	0	0	0	0	0	0	0	0	0	0	0	0	0	0	0	
	↓	GS254	0	1	1	1	1	1	1	1	0	0	0	0	0	0	0	0	0	0	0	0	0	0	0	
	Red	GS255	1	1	1	1	1	1	1	1	0	0	0	0	0	0	0	0	0	0	0	0	0	0	0	
Gray Scale of Green	Black	GS0	0	0	0	0	0	0	0	0	0	0	0	0	0	0	0	0	0	0	0	0	0	0	0	
	↑	GS1	0	0	0	0	0	0	0	1	0	0	0	0	0	0	0	0	0	0	0	0	0	0	0	
	Darker	GS2	0	0	0	0	0	0	0	0	1	0	0	0	0	0	0	0	0	0	0	0	0	0	0	
	↑	↓				↓							↓									↓				
	↓	↓				↓							↓									↓				
	Brighter	GS253	0	0	0	0	0	0	0	0	1	0	1	1	1	1	1	1	0	0	0	0	0	0	0	
	↓	GS254	0	0	0	0	0	0	0	0	0	1	1	1	1	1	1	1	0	0	0	0	0	0	0	
	Green	GS255	0	0	0	0	0	0	0	0	1	1	1	1	1	1	1	1	0	0	0	0	0	0	0	
Gray Scale of Blue	Black	GS0	0	0	0	0	0	0	0	0	0	0	0	0	0	0	0	0	0	0	0	0	0	0	0	
	↑	GS1	0	0	0	0	0	0	0	0	0	0	0	0	0	0	0	1	0	0	0	0	0	0	0	
	Darker	GS2	0	0	0	0	0	0	0	0	0	0	0	0	0	0	0	0	1	0	0	0	0	0	0	
	↑	↓				↓							↓									↓				
	↓	↓				↓							↓									↓				
	Brighter	GS253	0	0	0	0	0	0	0	0	0	0	0	0	0	0	0	1	0	1	1	1	1	1	1	
	↓	GS254	0	0	0	0	0	0	0	0	0	0	0	0	0	0	0	0	1	1	1	1	1	1	1	
	Blue	GS255	0	0	0	0	0	0	0	0	0	0	0	0	0	0	0	1	1	1	1	1	1	1	1	

- 0: Low level voltage,
- 1: High level voltage.

Each basic color can be displayed in 256 gray scales from 8 bit data signals. According to the combination of total 24 bit data signals, the 16,777,216 colors display can be achieved on the screen.

9.Optical characteristics

Ta=25°C

Parameter		Symbol	Condition	Min.	Typ.	Max.	Unit	Remark
Viewing angle range	Horizontal	$\theta 21, \theta 22$	CR>TBD	TBD	TBD	-	Deg.	
	Vertical	$\theta 11, \theta 12$		TBD	TBD	-	Deg.	
Viewing angle range	Horizontal	$\theta 21, \theta 22$	CR>TBD	TBD	TBD	-	Deg.	[Note1,4]
	Vertical	$\theta 11, \theta 12$		TBD	TBD	-	Deg.	
Contrast ratio		CRn	$\theta = 0^\circ$	TBD	TBD	-	-	[Note2,4]
Response time		tr/td	$\theta = 0^\circ$	-	TBD	-	Ms	[Note3(Condition1),4,5]
Chromaticity	White	x	$\theta = 0^\circ$				-	[Note4]
		y					-	
	Red	x					-	
		y					-	
	Green	x					-	
		y					-	
Blue	x				-			
	y				-			
Luminance	White	Y_L				cd/m ²	[Note4]	
uniformity	White	δw			1.43	-	[Note 6]	

*The measurement shall be executed 60 minutes after lighting at rating.

*Need a CPL' s base BACK LIGHT to discuss about the Optical characteristics.

【Note】 The optical characteristics are measured using the following equipment.

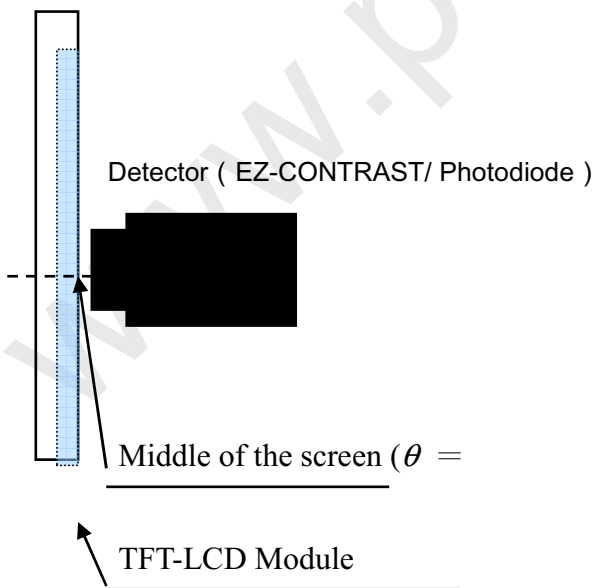

Fig.10-1 Measurement of viewing angle range and Response time.
(Viewing angle range: EZ-CONTRAST, Response time: Photodiode)

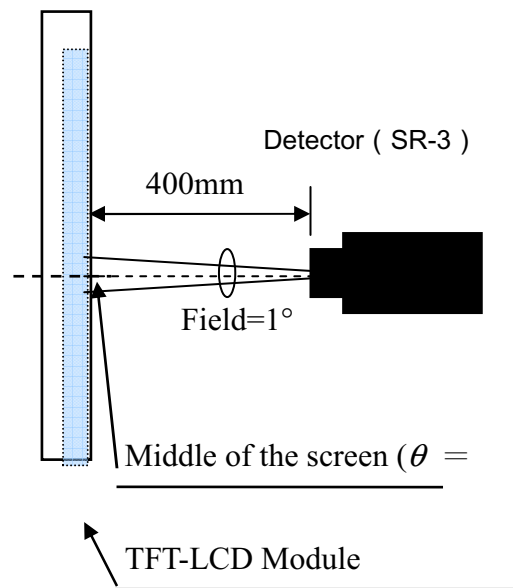

Fig.10-2 Measurement of Contrast, Luminance, Chromaticity and Response time.

[Note 1]Definitions of viewing angle range:

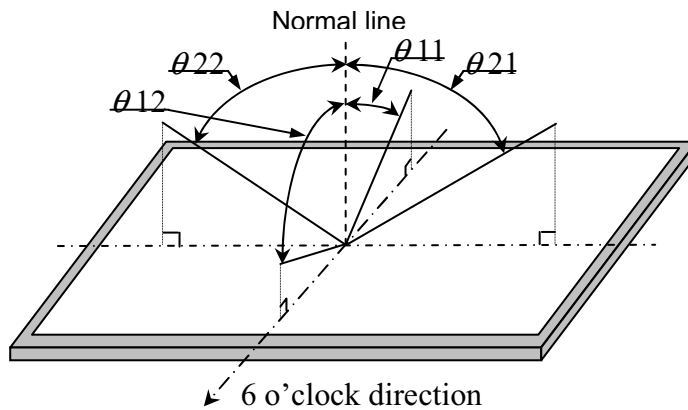

Fig.11 Viewing angle

[Note 2]Definition of contrast ratio:

The contrast ratio is defined as the following.

$$\text{Contrast Ratio} = \frac{\text{Luminance(Brightness) with all pixels white}}{\text{Luminance(Brightness) with all pixels Black}}$$

[Note 3]Definition of response time

The response time (τ_{DRV}) is defined as the following figure and shall be measured by switching the input signal for “ any level of gray (0%, 25%, 50%, 75% and 100%)” and “ any level of gray (0%, 25%, 50%, 75% and 100%)” .

	0%	25%	50%	75%	100%
0%		$\tau_r:0\% - 25\%$	$\tau_r:0\% - 50\%$	$\tau_r:0\% - 75\%$	$\tau_r:0\% - 100\%$
25%	$\tau_d:25\% - 0\%$		$\tau_r:25\% - 50\%$	$\tau_r:25\% - 75\%$	$\tau_r:25\% - 100\%$
50%	$\tau_d:50\% - 0\%$	$\tau_d:50\% - 25\%$		$\tau_r:50\% - 75\%$	$\tau_r:50\% - 100\%$
75%	$\tau_d:75\% - 0\%$	$\tau_d:75\% - 25\%$	$\tau_d:75\% - 50\%$		$\tau_r:75\% - 100\%$
100%	$\tau_d:100\% - 0\%$	$\tau_d:100\% - 25\%$	$\tau_d:100\% - 50\%$	$\tau_d:100\% - 75\%$	

$\tau^*:x-y$...response time from level of gray(x) to level of gray(y)

$$\tau_{DRV} = (\tau^*:x-y)/20$$

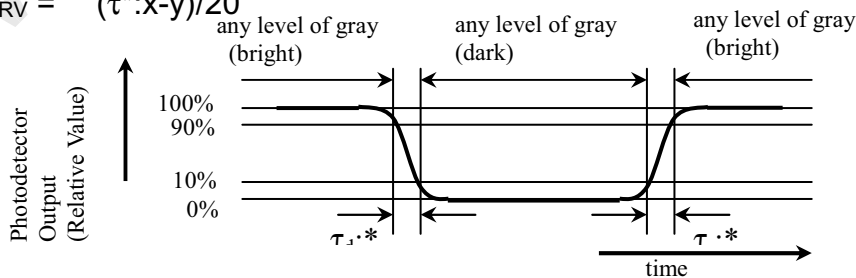

Fig. Response time

[Note 4] This shall be measured at center of the screen.

When black brightness is a max value, the specification of the contrast is satisfied.

[Note 5] This value is valid when O/S driving is used at typical input time value.

[Note 6]Definition of white uniformity;

White uniformity is defined as the following with five measurements. (A ~ E)

$$\delta w = \frac{\text{Maximum luminance of five points (brightness)}}{\text{Minimum luminance of five points (brightness)}}$$

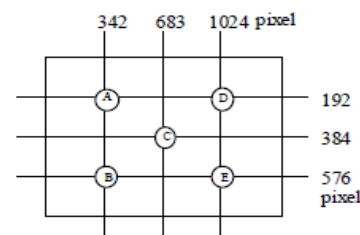

[Note 7] This shall be measured in which case reference voltage is set below and stipulated ROM version is used.

$$\left[\begin{array}{l} \text{VL0= TBD, VH0= TBD, VL56= TBD, VH56= TBD, VL72= TBD, VH72= TBD,} \\ \text{VL176= TBD, VH176= TBD, VL255= TBD, VH255= TBD} \end{array} \right]$$

10. Handling Precautions of the Open-cell

- Be sure to turn off the power supply when inserting or disconnecting the cable.
- Be sure to design the cabinet so that the module can be installed without any extra stress such as warp or twist.
- Since the front polarizer is easily damaged, pay attention not to scratch it.
- Since long contact with water may cause discoloration or spots, wipe off water drop immediately.
- When the panel surface is soiled, wipe it with absorbent cotton or other soft cloth.
- Since the panel is made of glass, it may break or crack if dropped or bumped on hard surface. Handle with care.
- Since CMOS LSI is used in this module, take care of static electricity and take the human earth into consideration when handling.
- The module has some printed circuit boards (PCBs) on the back side, take care to keep them from any stress or pressure when handling or installing the module; otherwise some of electronic parts on the PCBs may be damaged.
- Observe all other precautionary requirements in handling components.
- When some pressure is added onto the module from rear side constantly, it causes display non-uniformity issue, functional defect, etc. So, please avoid such design.

- k) When giving a touch to the panel at power on supply, it may cause some kinds of degradation. In that case, once turn off the power supply, and turn on after several seconds again, and that is disappear.
- l) When handling LCD modules and assembling them into cabinets, please be noted that long-term storage in the environment of oxidization or deoxidization gas and the use of such materials as reagent, solvent, adhesive, resin, etc. which generate these gasses, may cause corrosion and discoloration of the LCD modules.
- m) This LCD module is designed to prevent dust from entering into it. However, there would be a possibility to have a bad effect on display performance in case of having dust inside of LCD module. Therefore, please ensure to design your TV set to keep dust away around LCD module.

11.Packing form

- a) Piling number of cartons : TBD
- b) Packing quantity in one carton : TBD
- c) Carton size : TBD
- d) Total mass of one carton filled with full open-cell : TBD

12.Reliability test item

No	Test item	Condition
1	High temperature storage test	Ta= 60°C 240h
2	Low temperature storage test	Ta=-25°C 240h
3	High temperature and high humidity operation test	Ta= 40°C ; 95%RH 240h (No condensation)
4	High temperature operation test	Ta= 50°C 240h
5	Low temperature operation test	Ta= 0°C 240h
8	ESD	* At the following conditions, it is a thing without incorrect operation and destruction. (1) Non-operation: Contact electric discharge $\pm 10\text{kV}$ Non-contact electric discharge $\pm 20\text{kV}$ (2) Operation Contact electric discharge $\pm 8\text{kV}$ Non-contact electric discharge $\pm 15\text{kV}$ Conditions: 150pF, 330ohm

【Result evaluation criteria】

Under the display quality test condition with normal operation state, there shall be no

change, which may affect practical display function.

13.Others

- 1) Lot No. Label TBD
- 2) Packing label TBD
- 3) Adjusting volume has been set optimally before shipment, so do not change any adjusted value. If adjusted value is changed, the specification may not be satisfied.
- 4) Disassembling the module can cause permanent damage and should be strictly avoided.
- 5) Please be careful since image retention may occur when a fixed pattern is displayed for a long time.
- 6) The chemical compound, which causes the destruction of ozone layer, is not being used.
- 7) When any question or issue occurs, it shall be solved by mutual discussion.
- 8) This Open-cell is corresponded to RoHS.

14.Carton Storage condition

Temperature 0°C to 40°C

Humidity 95%RH or less

Reference condition: 20°C to 35°C, 85%RH or less (summer)

5°C to 15°C, 85%RH or less (winter)

The total storage time (40°C, 95%RH): 240H or less.

Sunlight Be sure to shelter a product from the direct sunlight.

Atmosphere Harmful gas, such as acid and alkali which bites electronic components and/or wires must not be detected.

[Notes]: Be sure to put cartons on palette or base, don't put it on floor, and store them with removing from wall. Please take care of ventilation in storehouse and around cartons, and control changing temperature is within limits of natural environment.

Storage life 1 year

15. Precautions

- a) Because the Open-Cell is too weak to destroy by static electricity, please don't touch the terminal with bare hands.
- b) Front polarizer can easily be damaged. Pay attention on it.
- c) Since long contact with drops of water may cause discoloration or spots, please wipe off them as soon as possible.
- d) When the panel surface is soiled, wipe it with absorbent cotton or other soft cloth.
- e) The Panel will be broken or chipped when it is dropped or bumped against a hard

substance.

f) Precautions of peeling off the Protection film:

- Be sure to peel off slowly (recommended more than 7 sec.) and constant speed.
- Peeling direction shown in the next Fig.
- Be sure to ground person with adequate methods such as the anti-static wrist band.
- Be sure to connect S-PWBs to GND while peeling off the protection film.
- Ionized air should be blown to the surface while peeling off the protection film.
- The protection film must not touch drivers and S-PWBs.
- After the protection film has been peeled off, some adhesive may be remained on the polarizer. Please use isopropyl-alcohol to remove it.

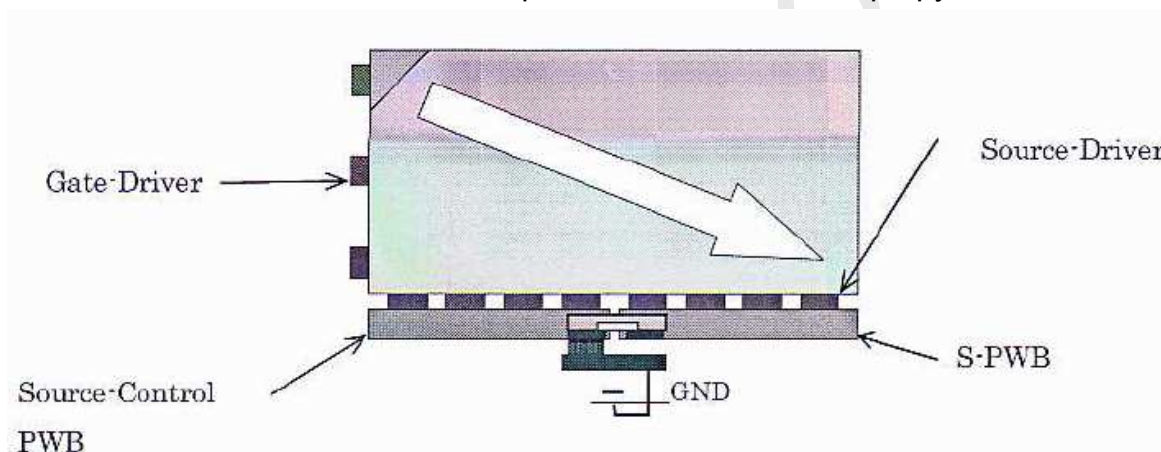

Fig. Direction of peeling off

- g) Since the Open-cell consists of TFT and electronic circuits with CMOS-ICs, which are very weak to electrostatic discharge, persons who are handling an Open-Cell should be grounded through adequate methods such as an anti-static wrist band. Connector pins should not be touched directly with bare hands.

Reference: Process control standard of CPL.

	item	Management standard value and performance standard
1	Anti-static mat(shelf)	1to50[Mega ohm]
2	Anti-static mat(floor, desk)	1to100[Mega ohm]
3	Ionizer	Attenuate from $\pm 1000V$ to $\pm 100V$ within two seconds.
4	Anti-static wrist band	0.8 to 10 [Mega ohm]
5	Anti-static wrist band entry and ground resistance	Below 1000[ohm]

PANDA

2011-5-3

6	Temperature	22 to 26 [°C]
7	Humidity	60 to 70 [%]

- h) Since the Open-cell has some PWBS, please take care to keep them off any stress or pressure when handling or installing the Open-cell, otherwise some of electronic parts on them may be damaged.
- i) Be sure to turn off the power supply when inserting or disconnecting the cable.
- j) Be sure to design the module and cabinet so that the Open-cell van is installed without any extra stress such as warp or twist.
- k) When handling and assembling Open-Cell into module, please be noted that long-term storage in the environment of oxidization or deoxidization gas and the use of materials such as reagent, solvent, adhesive, resin, etc. which generate these gasses, may cause corrosion and discoloration of the Open-Cell.
- l) Applying too much force and stress to PWBs and drivers may cause a malfunction electrically and mechanically.
- m) The Open-cell has high frequency circuits. Sufficient suppression to EMI should be done by system manufactures.
- n) Please be careful since image retention may occur when a fixed pattern is displayed for a long time.
- o) The chemical compound, which causes the destruction of ozone layer, is not being used.
- p) This Open-Cell module is corresponded to RoHs.
- q) When any question or issue occurs, it shall be solved by mutual discussion.

