



LP3910

Power Management IC for Hard Drive Based Portable Media Players

General Description

The LP3910 is a programmable system power management unit that is optimized for HDD-based Portable Media Players. The LP3910 incorporates 2 low-dropout LDO voltage regulators, 2 integrated Buck DC/DC converters with Dynamic Voltage Scaling (DVS), 1 wide load range Buck-Boost DC/DC converter with programmable output voltage, a 4-channel 8-bit A/D converter and a dual source Li-Ion/polymer battery charger. The charger has the capability to charge and maintain a single cell battery from a regulated wall adapter or USB power. When both USB and adapter sources are present, then the adapter source takes precedence and switching between USB and adapter power sources is seamless. In addition, the battery charger supports power routing, which allows system usage immediately after an external power source has been detected. The LP3910 also incorporates some advanced battery management functions such as battery temperature measurement, reverse current blocking for USB, LED charger status indication, thermally regulated internal power FETs, battery voltage monitoring, over-current protection and a 10 hour safety timer.

The Buck-Boost DC/DC converter targets the power management of Hard Disk Drives and maintains a typical operating voltage of $3.3V \pm 5\%$ with a battery voltage below or above this output level. The Buck-Boost output voltage can be selected to be as low as 1.8V.

The 4-channel A/D converter measures the battery voltage and charge current, which can be used for fuel gauging. Two undedicated channels can be used to measure other analog parameters such as discharge current, battery temperature, keyboard resistor scanning and more.

The various IC parameters are programmable through a 400 kHz I²C compatible interface.

The LP3910 is available in a thermally-enhanced 6x6x0.8 mm 48 LLP package and operates over an ambient temperature range of -40°C to $+85^{\circ}\text{C}$.

Features

- 2 low-dropout regulators -- LDO1 is used for general purpose applications, LDO2 is used for low-noise analog applications. Both LDOs have programmable output voltages.
- Green and Red LED charger status drivers
- 4-channel 8-bit dual slope a/d converter
- 2 High-efficiency DVS Buck converters
- Wide load range Buck-Boost DC/DC converter
- 400 kHz I²C compatible interface
- Linear constant-current / constant-voltage charger for single cell lithium-ion batteries
- USB and Adapter charging
- System power supply management
- 6x6x0.8mm 48 LLP package
- Voltage and thermal supervisory circuits
- Continuous battery voltage monitoring
- Interrupt Request output with 8 sources

Key Specifications

- LDO1: 150 mA, 1.2V–3.3V
- LDO2: 150 mA, 1.3V–3.3V
- Buck1: 600 mA, 0.8V–2.0V
- Buck2: 600 mA, 1.8V–3.3V
- Buck-Boost: 1000 mA, 1.8V–3.3V
- 50 mΩ battery path resistance
- 100 mA–1000 mA full-rate charge current using wall adapter
- Selectable 0.05C and 0.1C EOC current
- USB current limit of 100 mA, 500 mA, and 800 mA
- USB pre-qual current of 50 mA
- Selectable 4.1V, 4.2V or 4.38V battery termination voltages
- 0.35% battery termination accuracy
- ± 1 LSB INL/DNL on 8-bit a/d converter

Applications

- Hard drive-based MP3 players
- Portable media players
- Portable gaming devices

Typical Application Circuit

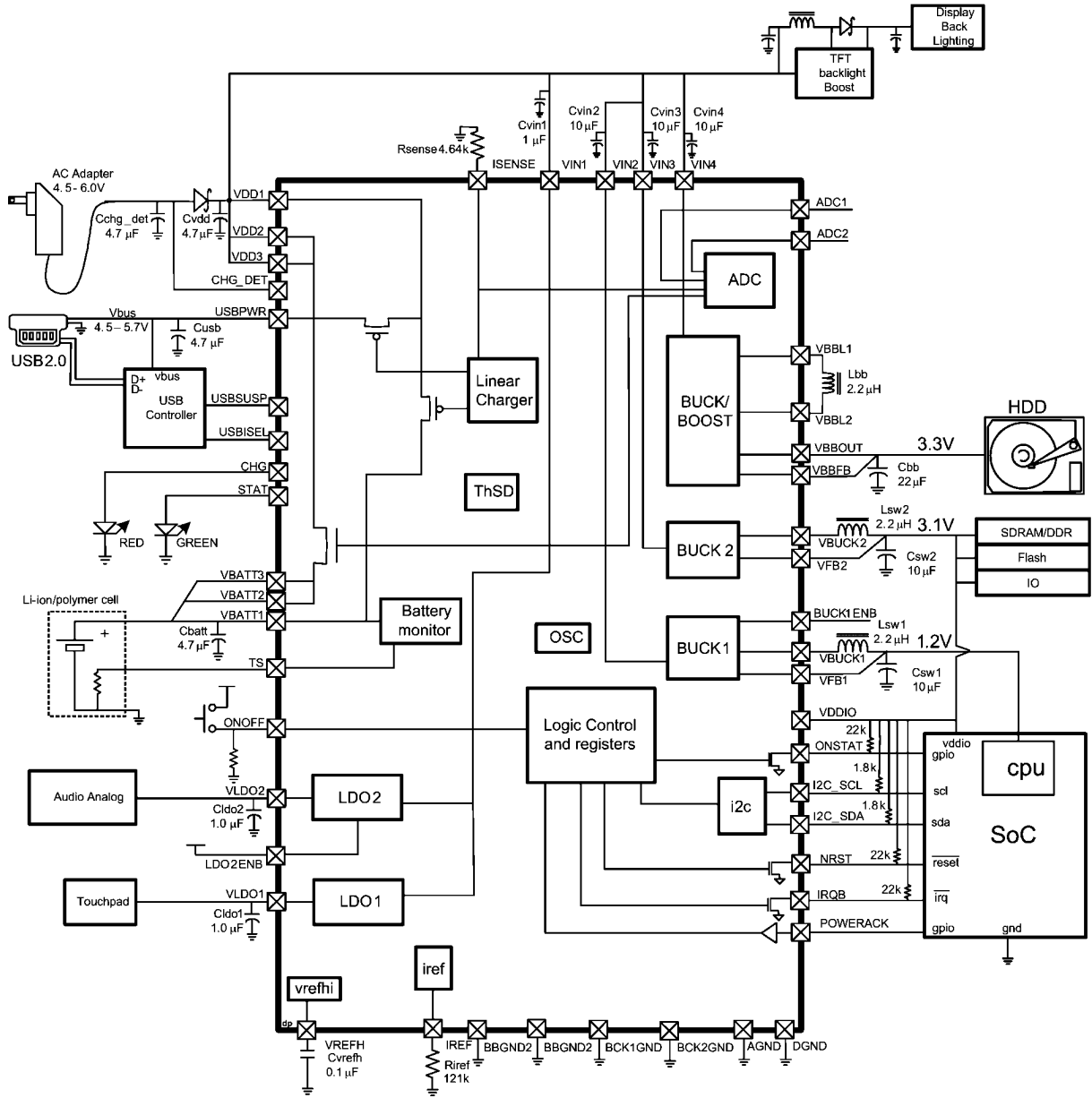

20212301

FIGURE 1. Application Diagram

Connection Diagram

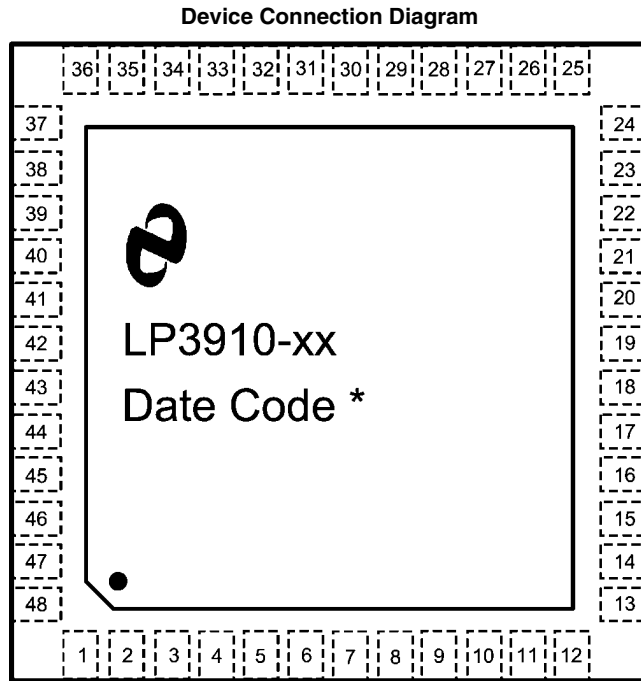

**48 LLP Package (Top View)
SQF48A**

20212302

The physical placement of the package marking will vary from part to part.

(*) UZXYTT format: 'U' – wafer fab code; 'Z' – assembly code; 'XY' 2 digit date code; 'TT' – die run code

See http://www.national.com/quality/marketing_conventions.html for more information on marking information.

Ordering Information

Order Number	Package Type	NSC Package Drawing	Top Mark	Supplied As
LP3910SQ-AA	48-lead LLP	SQF48A	LP3910SQ-AA	250 tape & reel
LP3910SQX-AA	48-lead LLP	SQF48A	LP3910SQX-AA	3000 tape & reel

Device Default Options

Order Number	LDO1	LDO2	Buck1	Buck2	BuckBoost	Other Options
LP3910SQ-AA	2.0V	3.3V	1.2V	3.3V	3.3V	Standard Defaults
LP3910SQX-AA	2.0V	3.3V	1.2V	3.3V	3.3V	Standard Defaults

Physical Dimensions inches (millimeters) unless otherwise noted

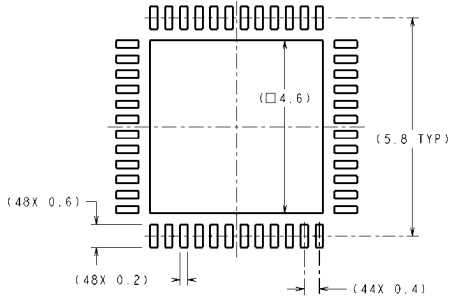

RECOMMENDED LAND PATTERN

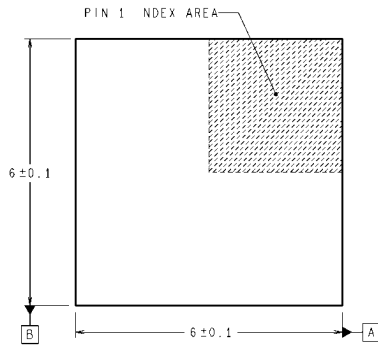

DIMENSIONS ARE IN MILLIMETERS
DIMENSIONS IN () FOR REFERENCE ONLY

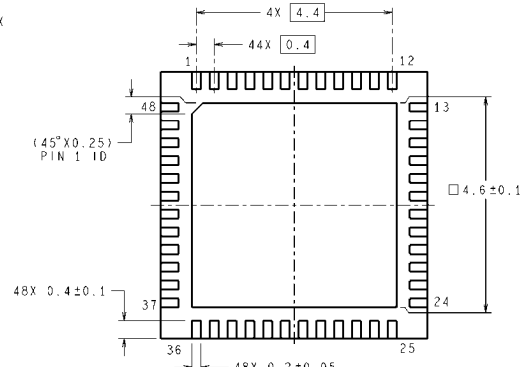
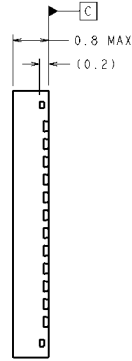
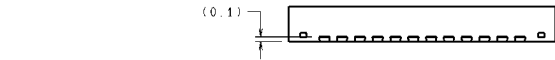

0.1	C	A	B
0.05	C		

SQF48A (Rev A)

SQF48A Package: 6x6x0.8mm 48-Pin LLP Package with 0.4mm Pitch

Notes

Notes

THE CONTENTS OF THIS DOCUMENT ARE PROVIDED IN CONNECTION WITH NATIONAL SEMICONDUCTOR CORPORATION ("NATIONAL") PRODUCTS. NATIONAL MAKES NO REPRESENTATIONS OR WARRANTIES WITH RESPECT TO THE ACCURACY OR COMPLETENESS OF THE CONTENTS OF THIS PUBLICATION AND RESERVES THE RIGHT TO MAKE CHANGES TO SPECIFICATIONS AND PRODUCT DESCRIPTIONS AT ANY TIME WITHOUT NOTICE. NO LICENSE, WHETHER EXPRESS, IMPLIED, ARISING BY ESTOPPEL OR OTHERWISE, TO ANY INTELLECTUAL PROPERTY RIGHTS IS GRANTED BY THIS DOCUMENT.

TESTING AND OTHER QUALITY CONTROLS ARE USED TO THE EXTENT NATIONAL DEEMS NECESSARY TO SUPPORT NATIONAL'S PRODUCT WARRANTY. EXCEPT WHERE MANDATED BY GOVERNMENT REQUIREMENTS, TESTING OF ALL PARAMETERS OF EACH PRODUCT IS NOT NECESSARILY PERFORMED. NATIONAL ASSUMES NO LIABILITY FOR APPLICATIONS ASSISTANCE OR BUYER PRODUCT DESIGN. BUYERS ARE RESPONSIBLE FOR THEIR PRODUCTS AND APPLICATIONS USING NATIONAL COMPONENTS. PRIOR TO USING OR DISTRIBUTING ANY PRODUCTS THAT INCLUDE NATIONAL COMPONENTS, BUYERS SHOULD PROVIDE ADEQUATE DESIGN, TESTING AND OPERATING SAFEGUARDS.

EXCEPT AS PROVIDED IN NATIONAL'S TERMS AND CONDITIONS OF SALE FOR SUCH PRODUCTS, NATIONAL ASSUMES NO LIABILITY WHATSOEVER, AND NATIONAL DISCLAIMS ANY EXPRESS OR IMPLIED WARRANTY RELATING TO THE SALE AND/OR USE OF NATIONAL PRODUCTS INCLUDING LIABILITY OR WARRANTIES RELATING TO FITNESS FOR A PARTICULAR PURPOSE, MERCHANTABILITY, OR INFRINGEMENT OF ANY PATENT, COPYRIGHT OR OTHER INTELLECTUAL PROPERTY RIGHT.

LIFE SUPPORT POLICY

NATIONAL'S PRODUCTS ARE NOT AUTHORIZED FOR USE AS CRITICAL COMPONENTS IN LIFE SUPPORT DEVICES OR SYSTEMS WITHOUT THE EXPRESS PRIOR WRITTEN APPROVAL OF THE CHIEF EXECUTIVE OFFICER AND GENERAL COUNSEL OF NATIONAL SEMICONDUCTOR CORPORATION. As used herein:

Life support devices or systems are devices which (a) are intended for surgical implant into the body, or (b) support or sustain life and whose failure to perform when properly used in accordance with instructions for use provided in the labeling can be reasonably expected to result in a significant injury to the user. A critical component is any component in a life support device or system whose failure to perform can be reasonably expected to cause the failure of the life support device or system or to affect its safety or effectiveness.

National Semiconductor and the National Semiconductor logo are registered trademarks of National Semiconductor Corporation. All other brand or product names may be trademarks or registered trademarks of their respective holders.

Copyright© 2006 National Semiconductor Corporation

For the most current product information visit us at www.national.com



National Semiconductor Americas Customer Support Center
 Email: new.feedback@nsc.com
 Tel: 1-800-272-9959

National Semiconductor Europe Customer Support Center
 Fax: +49 (0) 180-530-85-86
 Email: europe.support@nsc.com
 Deutsch Tel: +49 (0) 69 9508 6208
 English Tel: +49 (0) 870 24 0 2171
 Français Tel: +33 (0) 1 41 91 8790

National Semiconductor Asia Pacific Customer Support Center
 Email: ap.support@nsc.com

National Semiconductor Japan Customer Support Center
 Fax: 81-3-5639-7507
 Email: jpn.feedback@nsc.com
 Tel: 81-3-5639-7560