



800mA Standalone Linear Li-Ion Battery Charger with Dual LED Display

General Description

The LP4061 is a complete constant-current/constant-voltage linear charger for single cell lithium-ion batteries. Its SOT package and low external component count make the LP4061 ideally suited for portable applications. Furthermore, the LP4061 is specifically designed to work within USB power specifications. No external sense resistor is needed, and no blocking diode is required due to the internal MOSFET architecture. Thermal feedback regulates the charge current to limit the die temperature during high power operation or high ambient temperature. The charge voltage is fixed at 4.2V, and the charge current can be programmed externally with a single resistor. The LP4061 automatically terminates the charge cycle when the charge current drops to 1/10th the programmed value after the final float voltage is reached. Other features include charge current monitor, under-voltage lockout, automatic recharge and a status pin to indicate charge termination and the presence of an input voltage.

Features

- ◆ Programmable Charge Current Up to 800mA
- ◆ No MOSFET, Sense Resistor or Blocking Diode Required
- ◆ Complete Linear Charger in SOT Package for Single Cell Lithium-ion Batteries
- ◆ Constant-Current/Constant-Voltage Operation with Thermal Regulation to Maximize
- ◆ Charge Rate Without Risk of Overheating
- ◆ Charges Single Cell Li-Ion Batteries Directly from USB Port
- ◆ Charge Voltage with $\pm 1\%$ Accuracy
- ◆ Available in SOT23-6 Package
- ◆ Charge Current Monitor Output for Gas Gauging
- ◆ Automatic Recharge
- ◆ 2.9V Trickle Charge Threshold
- ◆ C/10 Charge Termination

Order Information

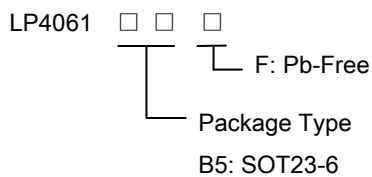

Applications

- ◇ Portable Media Players/MP3 players
- ◇ Cellular and Smart mobile phone
- ◇ PDA/DSC
- ◇ Bluetooth Applications

Typical Application Circuit

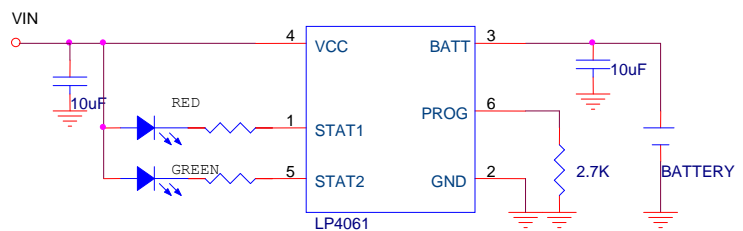

Marking Information

Part	Marking	Package	Shipping
LP4061	LPS BCYWX	SOT23-6	3K/REEL
Marking indication: Y:Production year W:Production week X:Production batch.			



Functional Pin Description

Package Type	Pin Configurations
SOT23-6	<p style="text-align: center;">TOP VIEW</p> <p style="text-align: center;">SOT23-6</p>

Pin Description

Pin	Name	Description
1	STAT1	Open-Drain Charge Status Output. When the battery is charging, the STAT pin is pulled low by an internal N-channel MOSFET. When the charge cycle is completed, the pin is pulled High.
2	GND	Ground.
3	BAT	Charge Current Output. Provides charge current to the battery and regulates the final float voltage to 4.2V. An internal precision resistor divider from this pin sets the float voltage which is disconnected in shutdown mode.
4	VCC	Positive Input Supply Voltage. It provides power to the charger. VCC can range from 4.35V to 6.5V and should be bypassed with at least a 1 μ F capacitor.
5	STAT2	Open-Drain Charge Status Output. When the battery is charging, the STAT pin is pulled High by an internal N-channel MOSFET. When the charge cycle is completed, the pin is pulled Low.
6	PROG	Charge Current Program, Charge Current Monitor and Shutdown Pin. The charge current is programmed by connecting a 1% resistor to ground(RPROG).



Function Block Diagram

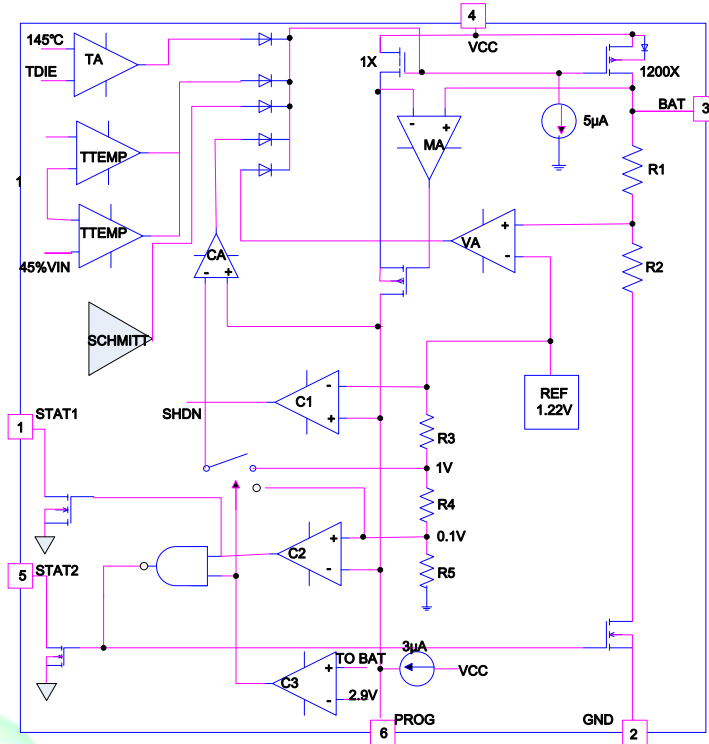

Absolute Maximum Ratings ^{Note 1}

- ✧ Input to GND(VCC) ----- -0.3V to 8V
- ✧ BAT to GND ----- -0.3V to 8V
- ✧ Other Pin to GND ----- -0.3V to 6V
- ✧ BAT Short-circuit Duration ----- Continuous
- ✧ Operation Temperature Range ----- -40°C to 85°C
- ✧ Junction Temperature ----- 150°C
- ✧ Storage Temperature ----- -45°C to 125°C
- ✧ Lead Temp (Soldering,10sec) ----- 260°C

Note Stresses beyond those listed under "Absolute Maximum Ratings" may cause permanent damage to the device. These are stress ratings only, and functional operation of the device at these or any other conditions beyond those indicated in the operational sections of the specifications is not implied. Exposure to absolute maximum rating conditions for extended periods may affect device reliability.

Thermal Information

- ✧ Maximum Power Dissipation (SOT23-5, P_D, T_A=25°C) ----- 0.45W
- ✧ Thermal Resistance (SOT23-5, θ_{JA}) ----- 250°C/W

ESD Susceptibility

- ✧ HBM(Human Body Mode) ----- 2KV
- ✧ MM(Machine Mode) ----- 200V



Electrical Characteristics

(Over $0^{\circ}\text{C} \leq T_J \leq 125^{\circ}\text{C}$ and recommended supply voltage)

Symbol	Parameter	Condition	Min	Typ	Max	Units
V _{CC}	Input Supply Voltage		4.35		6.5	V
I _{CC}	Input Supply Current	Charge Mode (Note 4), R _{PROG} =10k		350	2000	μA
		Standby Mode (Charge Terminated)		200	500	μA
		Shutdown Mode (R _{PROG} NC, V _{CC} <V _{BAT} , or V _{CC} <V _{UV})		25	50	μA
V _{FLOAT}	Regulated Output (Float) Voltage	0°C ≤ T _A ≤ 85°C, I _{BAT} =40mA	4.158	4.2	4.242	V
I _{BAT}	BAT Pin Current	R _{PROG} =10k, Current Mode		100	120	mA
		R _{PROG} =2k, Current Mode		500	600	mA
		Standby Mode, V _{BAT} =4.2V		-2.5	-6	μA
		Shutdown Mode (R _{PROG} NC)		± 1	± 2	μA
		Sleep Mode, V _{CC} =0V		± 1	± 2	μA
I _{TRIKL}	Trickle Charge Current	V _{BAT} <V _{TRIKL} , R _{PROG} =2k		30		mA
V _{TRIKL}	Trickle Charge Threshold Voltage	R _{PROG} =10k, V _{BAT} Rising	2.8	2.9	3.0	V
V _{TRHYS}	Trickle Charge Hysteresis Voltage	R _{PROG} =10k	60	80	110	mV
V _{UV}	V _{CC} Undervoltage Lockout Threshold	From V _{CC} Low to High	3.55	3.7	3.85	V
V _{UVHYS}	V _{CC} Undervoltage Lockout Hysteresis			200		mV
V _{ASD}	V _{CC} -V _{BAT} Lockout Threshold Voltage	V _{CC} from Low to High		100		mV
		V _{CC} from High to Low		80		mV
I _{TERM}	C/10 Termination Current Threshold	R _{PROG} =10k&2K		10		% I _{BAT}
V _{PROG}	PROG Pin Voltage	R _{PROG} =10k, Current Mode		1		V
I _{STAT}	STAT Pin Weak Pull-Down Current	V _{STAT} =5V			5	μA
V _{STAT}	STAT Pin Output Low Voltage	I _{STAT} =5mA		0.35	0.6	V
ΔV _{RECHRG}	Recharge Battery Threshold Voltage	V _{FLOAT} -V _{RECHRG}	100	150	200	mV
T _{LIM}	Junction Temperature in Constant Temperature Mode			150		°C
R _{ON}	Power FET "ON" Resistance (Between V _{CC} and BAT)			600		mΩ
t _{SS}	Soft-Start Time	I _{BAT} =0 to I _{BAT} =850V/R _{PROG}		100		μs



Application Information

The LP4061 is a single cell lithium-ion battery charger using a constant-current/constant-voltage algorithm. It can deliver up to 800mA of charge current (using a good thermal PCB layout) with a final float voltage accuracy of ±1%. The LP4061 includes an internal P-channel power MOSFET and thermal regulation circuitry. No blocking diode or external current sense resistor is required; thus, the basic charger circuit requires only two external components. Furthermore, the LP4061 is capable of operating from a USB power source.

Normal Charge Cycle

A charge cycle begins when the voltage at the VCC pin rises above the UVLO threshold level and a 1% program resistor is connected from the PROG pin to ground or when a battery is connected to the charger output. If the BAT pin is less than 2.9V, the charger enters trickle charge mode. In this mode, the LP4055 supplies fixed 30mA current to bring the battery voltage up to a safe level for full current charging.

When the BAT pin voltage rises above 2.9V, the charger enters constant-current mode, where the programmed charge current is supplied to the battery. When the BAT pin approaches the final float voltage, the LP4061 enters constant-voltage mode and the charge current begins to decrease. The charge cycle ends when the charge current drops to 1/10 of the programmed value.

Programming Charge Current

The charge current is programmed using a single resistor from the PROG pin to ground. The battery charge current is 1000 times the current out of the PROG pin. The program resistor and the charge current are calculated using the following equations:

$$R_{PROG}=1000V/I_{BAT} \quad I_{BAT}=1000V/R_{PROG}$$

The charge current out of the BAT pin can be determined at any time by monitoring the PROG pin voltage using the following equation:

$$I_{BAT}=V_{PROG}/R_{PROG} \times 1000$$

Charge Termination

A charge cycle is terminated when the charge current falls to 1/10th the PROG rammed value after the final float voltage is reached. This condition is detected by using an internal, filtered comparator to monitor the PROG pin. When the PROG pin voltage falls below 200mV for longer than tTERM(typically 1ms), charging is terminated. The charge current is latched off and the LP28056S enters standby mode, where the input supply current drops to 200µA. In this state, all loads on the BAT pin must be supplied by the battery. (Note: C/10 termination is disabled in trickle charging and thermal limiting modes).

Charge Status Indicator (STAT)

The charge status output has two different states: strong pull-down (~5mA) and high impedance. The strong pull-down state indicates that the LP4061 is in a charge cycle. Once the charge cycle has terminated, the pin state is determined by under voltage lockout conditions. High impedance indicates that the LP4061 is in under voltage lockout mode: either VCC is less than 100mV above the BAT pin voltage or insufficient voltage is applied to the VCC pin. A microprocessor can be used to distinguish between these two states

Function	STAT1	STAT2
Charging	Low	High
Charge Completed	High	Low

Charge Termination

An internal thermal feedback loop reduces the programmed charge current if the die temperature attempts to rise above a preset value of approximately 150°C. This feature protects the LP4061 from excessive temperature and allows the user to push the limits of the power handling capability of a given circuit board without risk of damaging the LP4061. The charge current can be set according to typical (not worst-case) ambient temperature with the assurance that the charger will automatically reduce the current in worst-case conditions.



Under voltage Lockout (UVLO)

An internal under voltage lockout circuit monitors the input voltage and keeps the charger in shutdown mode until V_{CC} rises above the under voltage lockout threshold. The UVLO circuit has a built-in hysteresis of 200mV. Furthermore, to protect against reverse current in the power MOSFET, the UVLO circuit keeps the charger in shutdown mode if V_{CC} falls to within 80mV of the battery voltage. If the UVLO comparator is tripped, the charger will not come out of shutdown mode until V_{CC} raises 100mV above the battery voltage.

Manual Shutdown

At any point in the charge cycle, the LP4061 can be put into shutdown mode by removing R_{PROG} thus floating the PROG pin. This reduces the battery drain current to less than 2 μ A and the supply current to less than 50 μ A. A new charge cycle can be initiated by reconnecting the program resistor.

Automatic Recharge

Once the charge cycle is terminated, the LP4061A continuously monitors the voltage on the BAT pin using a comparator with a 2ms filter time (t_{RECHRG}). A charge cycle restarts when the battery voltage falls below 4.05V (which corresponds to approximately 80% to 90% battery capacity). This ensures that the battery is kept at or near a fully charged condition and eliminates the need for periodic charge cycle initiations. CHRG output enters a strong pull-down state.

Power Dissipation

The conditions that cause the LP4061 to reduce charge current through thermal feedback can be approximated by considering the power dissipated in the IC. Nearly all of this power dissipation is generated by the internal MOSFET—this is calculated to be approximately:

$$P_D = (V_{CC} - V_{BAT}) \times I_{BAT}$$

Where P_D is the power dissipated, V_{CC} is the input supply voltage, V_{BAT} is the battery voltage and I_{BAT} is the charge current. The approximate ambient temperature at which the thermal feedback begins to protect the IC is:

$$T_A = 150^\circ\text{C} - P_D \theta_{JA}$$

$$T_A = 150^\circ\text{C} - (V_{CC} - V_{BAT}) \times I_{BAT} \times \theta_{JA}$$

VCC Bypass Capacitor

Many types of capacitors can be used for input bypassing; however, caution must be exercised when using multilayer ceramic capacitors. Because of the self-resonant and high Q characteristics of some types of ceramic capacitors, high voltage transients can be generated under some start-up conditions, such as connecting the charger input to a live power source. Adding a 1.5 Ω resistor in series with an X5R ceramic capacitor will minimize start-up voltage transients.

Layout Considerations

- ✧ Follow the PCB layout guidelines for optimal performance of LP4061.
- ✧ For the main current paths as indicated in bold lines, keep their traces short and wide.
- ✧ Put the input capacitor as close as possible to the device pins (VCC and GND).
- ✧ Connect all analog grounds to a command node and then connect the command node to the power ground behind the output capacitors.
- ✧ Output not connect loading when charging.



Packaging Information

SOT23-6

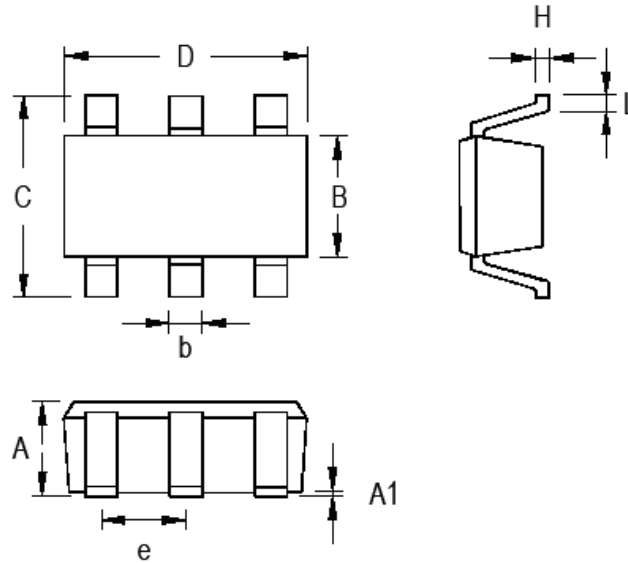

Symbol	Dimensions In Millimeters		Dimensions In Inches	
	Min	Max	Min	Max
A	0.889	1.295	0.031	0.051
A1	0.000	0.152	0.000	0.006
B	1.397	1.803	0.055	0.071
b	0.250	0.560	0.010	0.022
C	2.591	2.997	0.102	0.118
D	2.692	3.099	0.106	0.122
e	0.838	1.041	0.033	0.041
H	0.080	0.254	0.003	0.010
L	0.300	0.610	0.012	0.024