



Over Voltage and Over Current Protection IC

General Description

The LP5301 is an Over-Voltage-Protection(OVP) and programmable Over-Current-Protection (OCP) device. The device will switch off internal MOSFET to disconnect VIN to VOUT to protect load when any of input voltage, input current over the threshold. The Over temperature protection (OTP) function monitors chip temperature to protect the device.

The LP5301 is available in SOT-23-6, DFN-8 2*2mm package. Standard products are Pb-free and Halogen-free.

Features

- ◆ Input Voltage Range: 3.5V to 36V
- ◆ Typical Output Power on Time: 9ms
- ◆ OVP Threshold: 6.1V
- ◆ OVP Threshold Time Less Than 1 μ s
- ◆ Programmable Current Limit up to 2.1A
- ◆ Low R_{DS(ON)} Internal Switches:130m Ω @ 5V /1A
- ◆ Output Discharge
- ◆ Thermal Fault Protection
- ◆ SOT23-6, DFN-8 2*2mmPackage
- ◆ RoHS Compliant and 100% Lead(Pb)-Free

Order Information

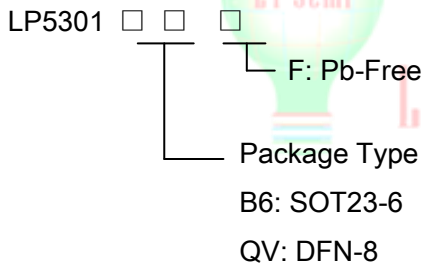

Applications

- ◇ GPS
- ◇ PMP
- ◇ PAD
- ◇ MID
- ◇ Digital cameras, Digital Videos

Typical Application Circuit

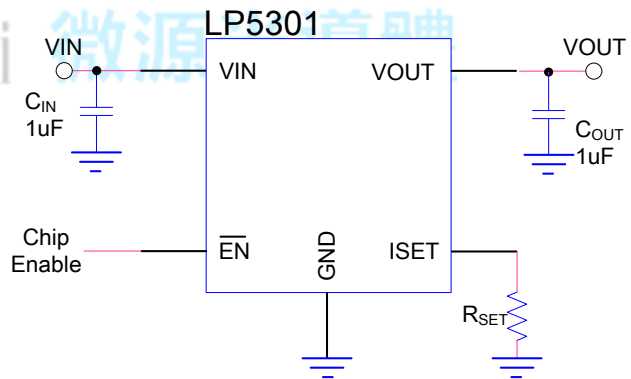

Marking Information

Device	Marking	Package	Shipping
LP5301B6F	9WYWX	SOT23-6	3K/REEL
LP5301QVF	LPS LP5301 YWX	DFN-8	3K/REEL

Marking indication:
Y:Production year W:Production week X:Production batch



Functional Pin Description

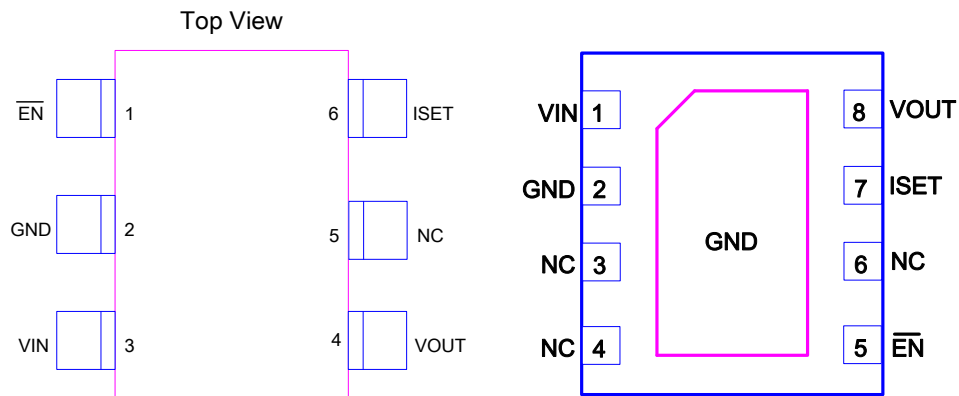

Pin Description

Pin		Name	Description
SOT23-6	DFN-8		
1	5	$\overline{\text{EN}}$	Chip enable pin. Active low.
2	2,PAD	GND	Ground.
3	1	VIN	Input pin. A 1uF low ESR ceramic capacitor or larger must be connected as close as to this pin. It is recommended to use 50V capacitor or according to application.
4	8	VOUT	Output pin.
5	3,4,6	NC	No connector. These pin must be floating without connecting to GND or HIGH voltage.
6	7	ISET	Current program pin. Connect a resistor to ground.



Function Diagram

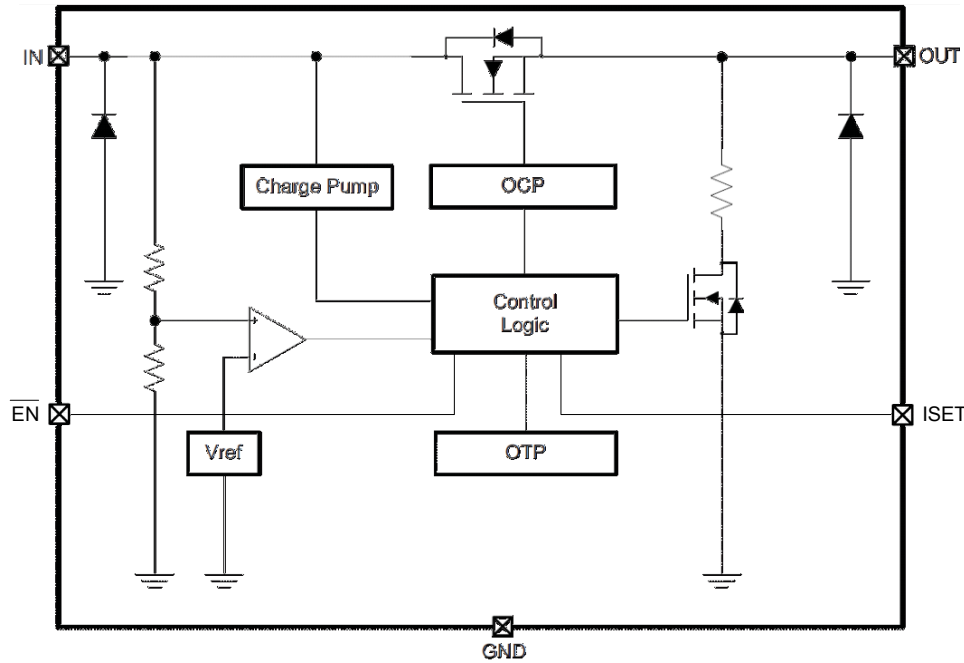

Absolute Maximum Ratings ^{Note 1}

- ◇ Input Voltage to GND ----- 36V
- ◇ Output Voltage to GND ----- 6.5V
- ◇ Other Pin to GND ----- 6V
- ◇ Maximum Junction Temperature ----- 150°C
- ◇ Operating Ambient Temperature Range (T_A) ----- -40°C to 85°C

Note 1. Stresses beyond those listed under “Absolute Maximum Ratings” may cause permanent damage to the device. These are stress ratings only, and functional operation of the device at these or any other conditions beyond those indicated in the operational sections of the specifications is not implied. Exposure to absolute maximum rating conditions for extended periods may affect device reliability.

Thermal Information

- ◇ Maximum Power Dissipation (SOT23-6, P_D, T_A=25°C) ----- 0.45W
- ◇ Thermal Resistance (SOT23-6, θ_{JA}) ----- 250°C/W
- ◇ Maximum Power Dissipation (DFN-8, P_D, T_A=25°C) ----- 1.5W
- ◇ Thermal Resistance (DFN-8, θ_{JA}) ----- 46°C/W

ESD Susceptibility

- ◇ HBM(Human Body Mode) ----- 2KV
- ◇ MM(Machine Mode) ----- 200V



Electrical Characteristics

$V_{IN}=5V$, $T_A=25^{\circ}C$, unless otherwise noted

Symbol	Parameter	Condition	Min	Typ	Max	Units
DC characteristics and Power-ON-Reset						
V_{IN}	Input Voltage		3.5		36	V
I_Q	Input quiescent current	EN=LOW, $I_{OUT}=0A$		110		μA
I_{SD}		EN=HIGH, $I_{OUT}=0A$			1	
R_{ON}	IN-to-OUT ON resistance	$I_{OUT}=1A$		130		m Ω
$R_{DISCHARGE}$	Output discharge resistance			4.3		k Ω
$V_{EN(L)}$	Enable Threshold Low	Chip enable			0.4	V
$V_{EN(H)}$	Enable Threshold High	Chip shutdown	1.4		5	V
UVLO	Under voltage lock out threshold	V_{IN} increasing from 0~5V	2.6	2.8	3	V
$V_{HYS-UVLO}$	Under voltage lock out hysteresis	V_{IN} decreasing from 5~0V		500		mV
T_{ON}	Output power-on time	EN=LOW, $V_{IN}=0 \rightarrow 5V$ to output ON		9		ms
	Turn on through EN	EN=HIGH \rightarrow LOW to output ON		9		
Input Over-Voltage-Protection (OVP)						
V_{OVP}	OVP threshold	V_{IN} increasing from 5~7V	5.8	6.1	6.4	V
$V_{HYS-OVP}$	OVP hysteresis	V_{IN} decreasing from 7~5V		300		mV
T_{OVP}	OVP active time	$V_{IN}=5 \rightarrow 10V$			1	μs
$T_{ON(OVP)}$	OVP recovery time	$V_{IN}=10 \rightarrow 5V$ to output ON		9		ms
Input Over-Current-Protection (OCP)						
I_{OCP}	OCP threshold	$R_{SET}=51K$		1.9		A
		$R_{SET}=82K$		1.3		
		$R_{SET}=150K$		0.85		
$I_{OCPLIMIT}$	OCP LIMIT Current	$R_{SET}=NC$	2.1	2.5		A
T_{OCP}	OCP active time			30		ms
V_{ISET}	ISET Voltage			0.8		V
$T_{ON(OCP)}$	OCP recovery time			1		s
Over-Temperature-Protection (OTP)						
T_{OTP}	OTP threshold			150		$^{\circ}C$
T_{OTP_HYS}	OTP hysteresis			20		$^{\circ}C$



Typical Operating Characteristics

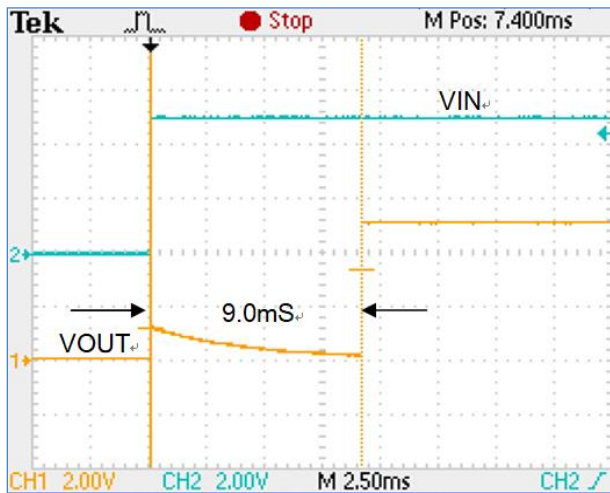
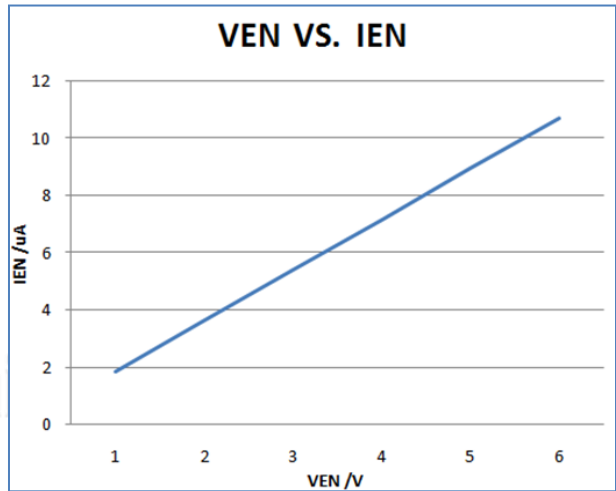
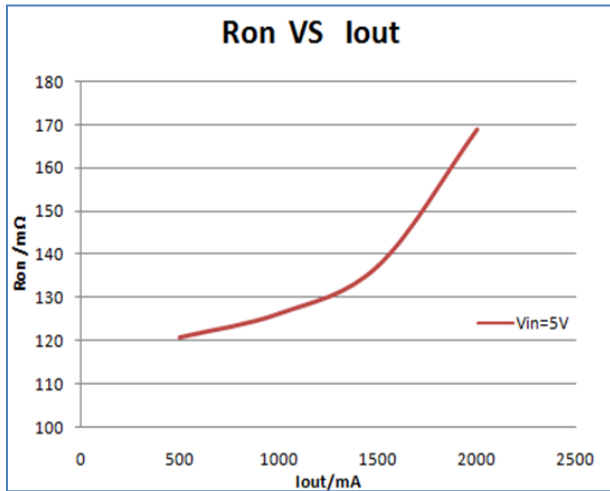
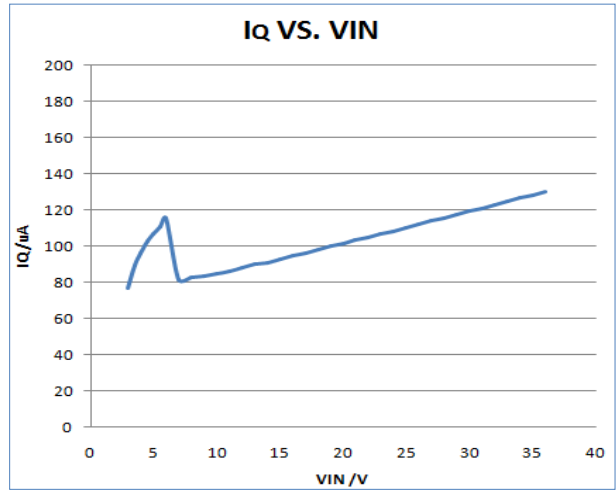
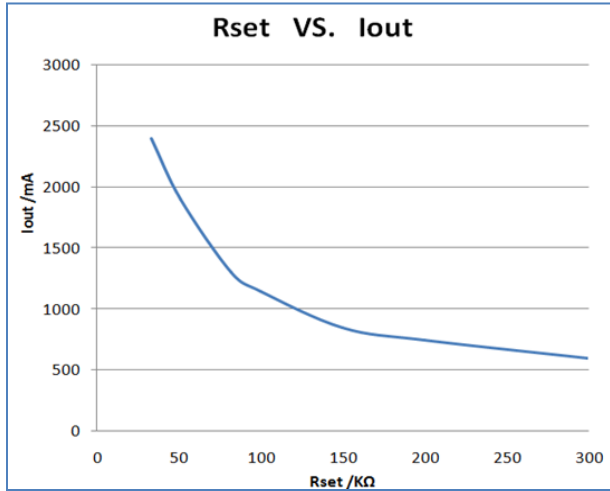

Turn on with $V_{EN}=0V$

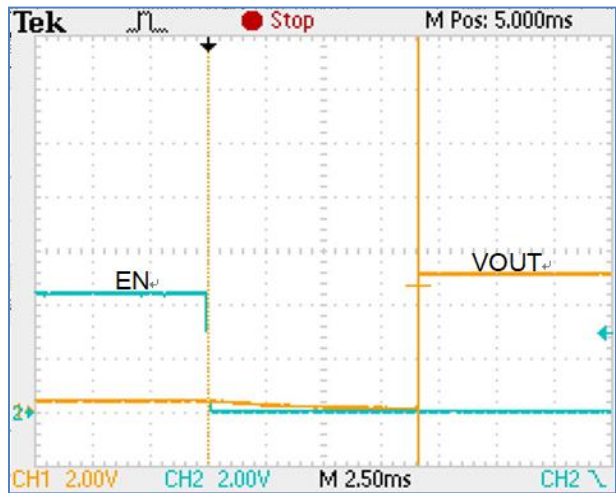

Turn on with $V_{IN}=5V$

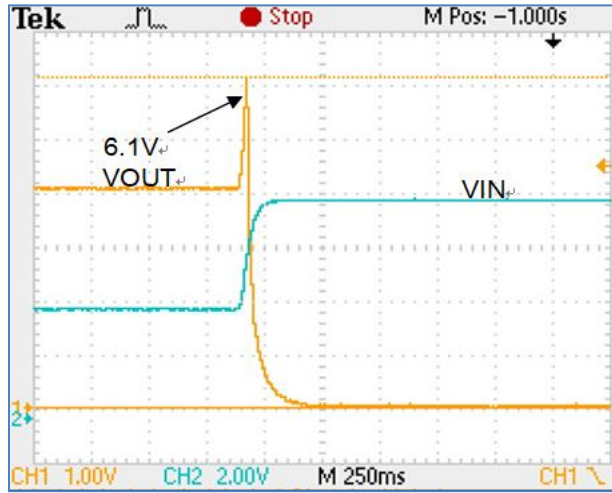

OVP waveform

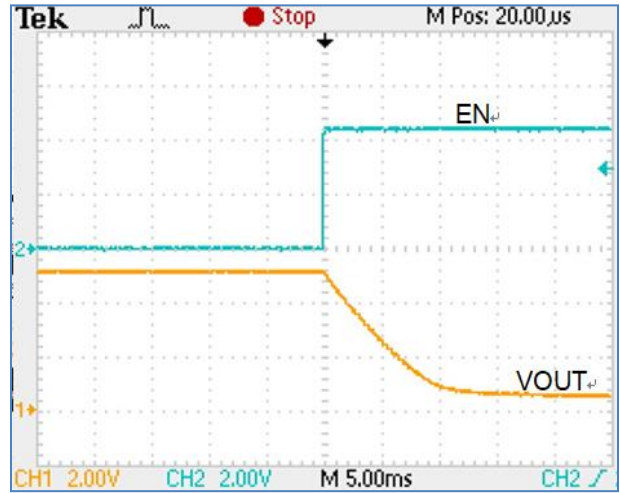

Turn off waveform with $I_{OUT}=0A$

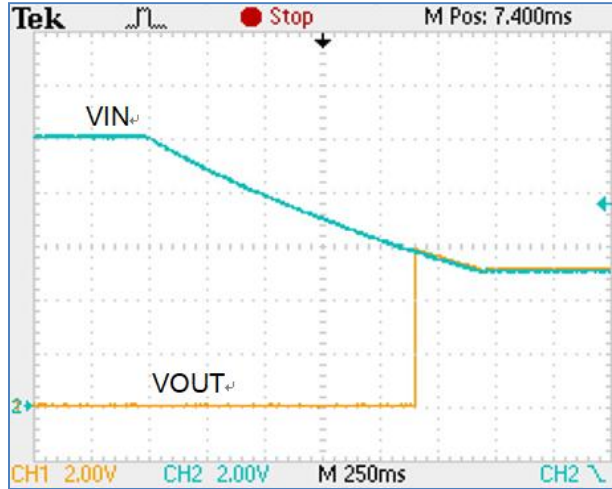

V_{IN} falling waveform

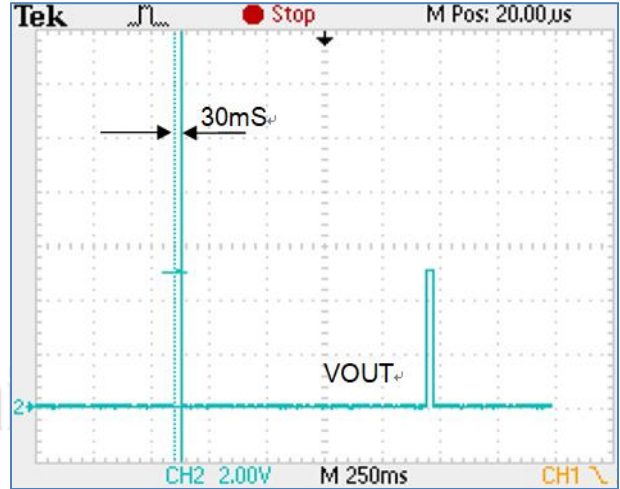

OCP detection time



Packaging Information

SOT23-6

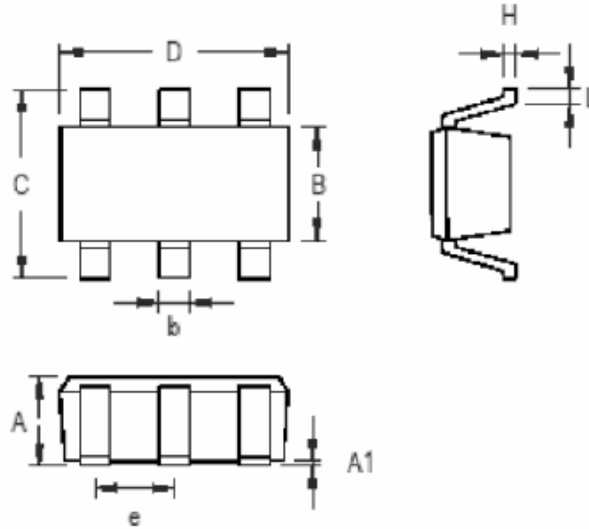

Symbol	Dimensions In Millimeters		Dimensions In Inches	
	Min	Max	Min	Max
A	0.889	1.295	0.031	0.051
A1	0.000	0.152	0.000	0.006
B	1.397	1.803	0.055	0.071
b	0.250	0.560	0.010	0.022
C	2.591	2.997	0.102	0.118
D	2.692	3.099	0.106	0.122
e	0.838	1.041	0.033	0.041
H	0.080	0.254	0.003	0.010
L	0.300	0.610	0.012	0.024

SOT-23-6 Surface Mount Package



DFN-8

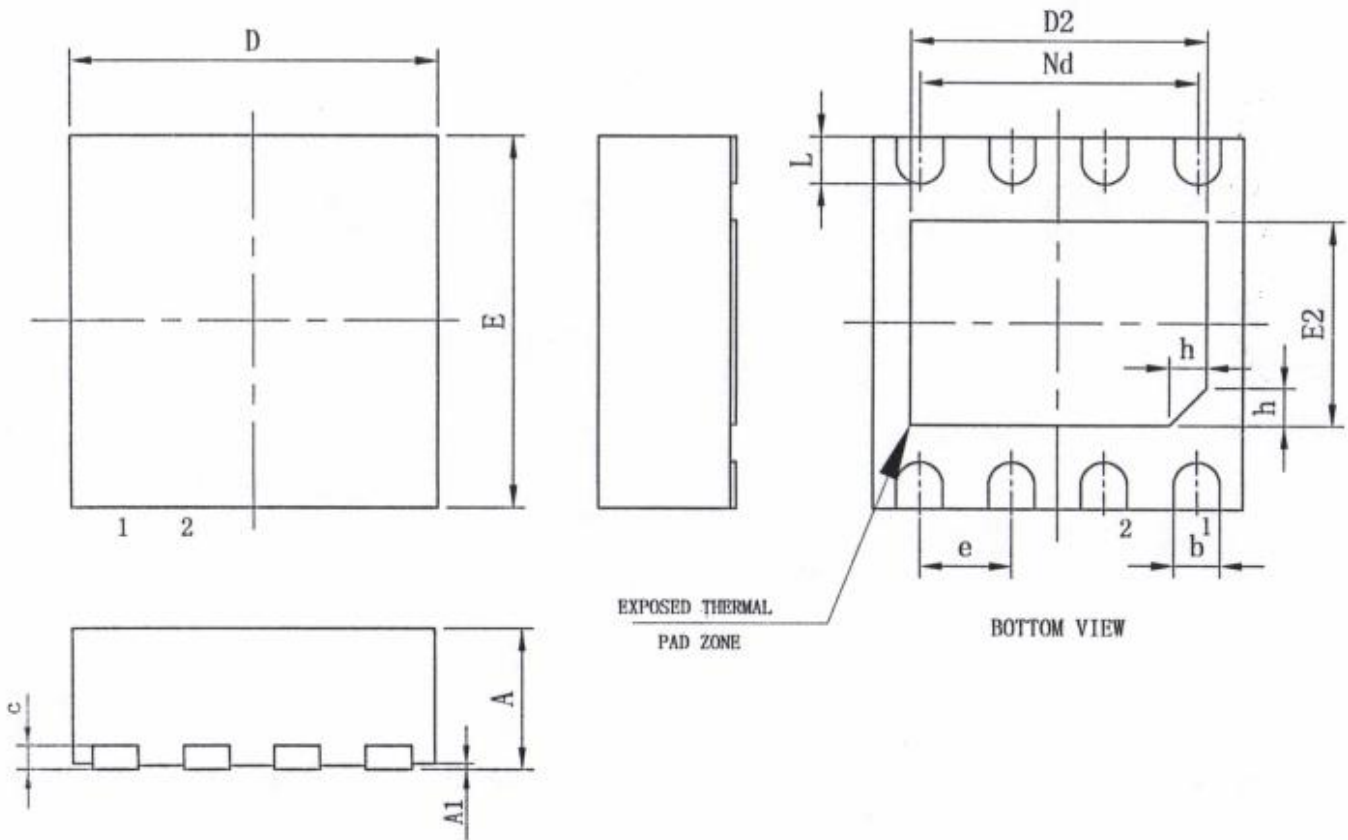

SYMBOL	MILLIMETER		
	MIN	NOM	MAX
A	0.70	0.75	0.80
A1	—	0.02	0.05
b	0.18	0.25	0.30
c	0.18	0.20	0.25
D	1.90	2.00	2.10
D2	1.50	1.60	1.70
e	0.50BSC		
Nd	1.50BSC		
E	1.90	2.00	2.10
E2	1.00	1.10	1.20
L	0.20	0.25	0.30
h	0.15	0.20	0.25