

LP5524 Parallel LED Driver with PWM Brightness Control in Micro SMD Package

General Description

The LP5524 is a highly integrated dual-zone LED driver that can drive up to four LEDs in parallel with a total output current of 100mA. Regulated high side internal current sources deliver excellent current and brightness matching in all LEDs.

LED driver current sources are split into two independently controlled banks for driving secondary displays, keypad and indicator LEDs. Brightness control is achieved by applying PWM signals to each enable pin. Default LED current is factory-programmable and an optional external resistor can be used to set LED current to user programmable values.

LP5524 is available in National's tiny 9-bump thin micro SMD package.

Features

- High side LED driver
- Drives 4 LEDs with Up to 25mA per LED
- Ultra-Small Solution Size:
 - No External Components
 - Micro SMD-9 Package with 0.4 mm pitch: 1.215mm x 1.215mm x 0.6mm (LxWxH)
- 0.4% Typical Current Matching
- PWM Brightness Control
- Over-Current Protection
- Wide Input Voltage Range: 2.7V to 5.5V

Applications

- Sub display Backlight
- Keypad LED Backlight
- Indicator LED

Typical Application

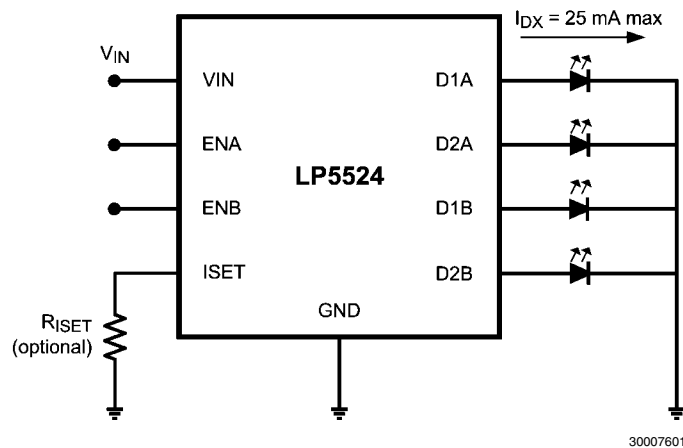

Connection Diagrams and Package Mark Information

Connection Diagrams

Micro SMD-9 package, 1.215 x 1.215 x 0.60 mm body size, 0.4 mm pitch NS Package Number TMD09AAA

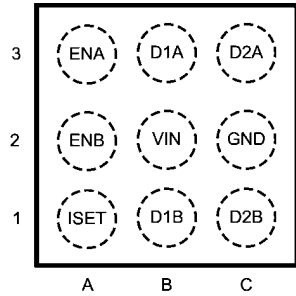

Top View

30007602

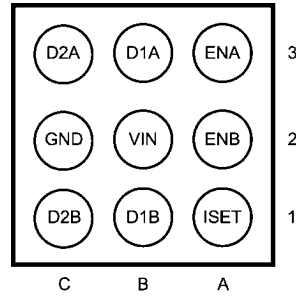

Bottom View

30007603

PACKAGE MARK

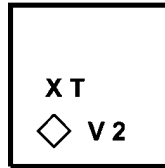

X = 1 Digit Date Code
 T = Die Traceability
 V2 = Product Identification
 ◇ = Pin A1

30007604

ORDERING INFORMATION

Order Number	Default LED Current (Note 1)	Package Marking	Supplied As	Spec/Flow
LP5524TM-5	5 mA	V2	TNR 250	NOPB
LP5524TMX-5	5 mA	V2	TNR 3000	NOPB

Note 1: Other current options are available upon request, please contact the National Semiconductor Sales Office.

PIN DESCRIPTIONS

Pin	Name	Type	Description
A1	ISET	AI	Current set input
A2	ENB	DI	Enable for bank B
A3	ENA	DI	Enable for bank A
B1	D1B	AO	Current source output, bank B LED1
B2	VIN	P	Power supply pin
B3	D1A	AO	Current source output, bank A LED1
C1	D2B	AO	Current source output, bank B LED2
C2	GND	G	Ground
C3	D2A	AO	Current source output, bank A LED2

A: Analog Pin **D:** Digital Pin **G:** Ground Pin **P:** Power Pin

I: Input Pin **O:** Output Pin

Absolute Maximum Ratings (Notes 2, 3)

If Military/Aerospace specified devices are required, please contact the National Semiconductor Sales Office/Distributors for availability and specifications.

V (VIN, DX, ISET)	-0.3V to +6.0V
Voltage on logic pins (ENA, ENB)	-0.3V to +6.0V
Continuous Power Dissipation (Note 4)	Internally Limited
Junction Temperature (T _{J-MAX})	125°C
Storage Temperature Range	-65°C to +150°C
Maximum Lead Temperature (Reflow soldering, 3 times)	(Note 5)
ESD Rating (Note 6)	
Human Body Model	2 kV

Operating Ratings (Notes 2, 3)

Voltage on power pin (VIN)	2.7V to 5.5V
Junction Temperature (T _J) Range	-40°C to +125°C
Ambient Temperature (T _A) Range (Note 7)	-40°C to +85°C

Thermal Properties

Junction-to-Ambient Thermal Resistance (θ _{JA}), TMD09 Package (Note 8)	80 - 125°C/W
---	--------------

Electrical Characteristics (Notes 3, 9)

Limits in standard typeface are for T_J = 25°C. Limits in **boldface** type apply over the operating ambient temperature range (-40°C < T_A < +85°C). Unless otherwise noted, specifications apply to the LP5524 Block Diagram with: V_{IN} = 3.6V, R_{ISET} = 32.4 kΩ, C_{IN} = 100 nF.

Symbol	Parameter	Condition	Min	Typ	Max	Units
I _{VIN}	Shutdown Supply Current	ENA = ENB = 0V		0.2	1	μA
	Active Mode Supply Current	ENA = ENB = H, ISET = open		170	210	μA
I _{DX}	Recommended LED Current		3		25	mA
I _{OUT}	LED Output Current Accuracy	I _{DX} = 5mA, V _{DX} = V _{IN} - 0.2V ISET = open		0.5	5	%
	LED Output Current Accuracy	I _{DX} = 15.9mA, V _{DX} = V _{IN} - 0.2V		0.5	4	%
I _{MATCH}	LED Current Matching (Note 10)	I _{DX} = 15.9mA		0.4	2.5	%
ΔI _{DX} %/ΔV _{IN}	Line Regulation			1		%/V
ΔI _{DX} %/ΔV _{DX}	Load Regulation	V _{DX} < V _{IN} - 0.2V		0.4		%/V
V _{HR}	Minimum Headroom Voltage (V _{IN} - V _{DX})(Note 11)	I _{DX} set to 5 mA		10		mV
		I _{DX} set to 15 mA		30	75	mV
I _{MIRROR}	External R _{ISET} to LED Current Mirroring Ratio			1:416		
V _{ISET}	ISET Reference Voltage			1.237		V
I _{ISET}	ISET Pin Current Range		2.5		62.5	μA
t _{PWM MIN}	Recommended Minimum On Time For PWM Signal			33		μs
V _{IL}	Logic Input Low Level				0.4	V
V _{IH}	Logic Input High Level		1.2			V
I _{IN}	CTRL Input Current	ENA / ENB = 1.2V		1.2	1.9	μA
t _{SD}	Shutdown Delay Time	Delay from ENA and ENB = low to I _{DX} = 0.1 x I _{DX} nom		20	25	μs

Note 2: Absolute Maximum Ratings indicate limits beyond which damage to the component may occur. Operating Ratings are conditions under which operation of the device is guaranteed. Operating Ratings do not imply guaranteed performance limits. For guaranteed performance limits and associated test conditions, see the Electrical Characteristics tables.

Note 3: All voltages are with respect to the potential at the GND pin.

Note 4: Internal thermal shutdown circuitry protects the device from permanent damage. Thermal shutdown engages at T_J=160°C (typ.) and disengages at T_J=140°C (typ.).

Note 5: For detailed soldering specifications and information, please refer to National Semiconductor Application Note AN1112: Micro SMD Wafer Level Chip Scale Package.

Note 6: The Human body model is a 100 pF capacitor discharged through a 1.5 kΩ resistor into each pin. MIL-STD-883 3015.7

Note 7: In applications where high power dissipation and/or poor package thermal resistance is present, the maximum ambient temperature may have to be derated. Maximum ambient temperature (T_{A-MAX}) is dependent on the maximum operating junction temperature (T_{J-MAX-OP} = 125°C), the maximum power dissipation of the device in the application (P_{D-MAX}), and the junction-to ambient thermal resistance of the part/package in the application (θ_{JA}), as given by the following equation: T_{A-MAX} = T_{J-MAX-OP} - (θ_{JA} × P_{D-MAX}).

Note 8: Junction-to-ambient thermal resistance is highly application and board-layout dependent. In applications where high maximum power dissipation exists, special care must be paid to thermal dissipation issues in board design.

Note 9: Min and Max limits are guaranteed by design, test, or statistical analysis. Typical numbers are not guaranteed, but do represent the most likely norm.

Note 10: Matching is the maximum difference from the average.

Note 11: The current source is connected internally between V_{IN} and V_{DX} . The voltage across the current source, $(V_{IN} - V_{DX})$, is referred to a Headroom Voltage (V_{HR}). Minimum Headroom Voltage is defined as the V_{HR} voltage when the LED current has dropped 20% from the value measured at $V_{DX} = V_{IN} - 1V$.

LP5524 Block Diagram

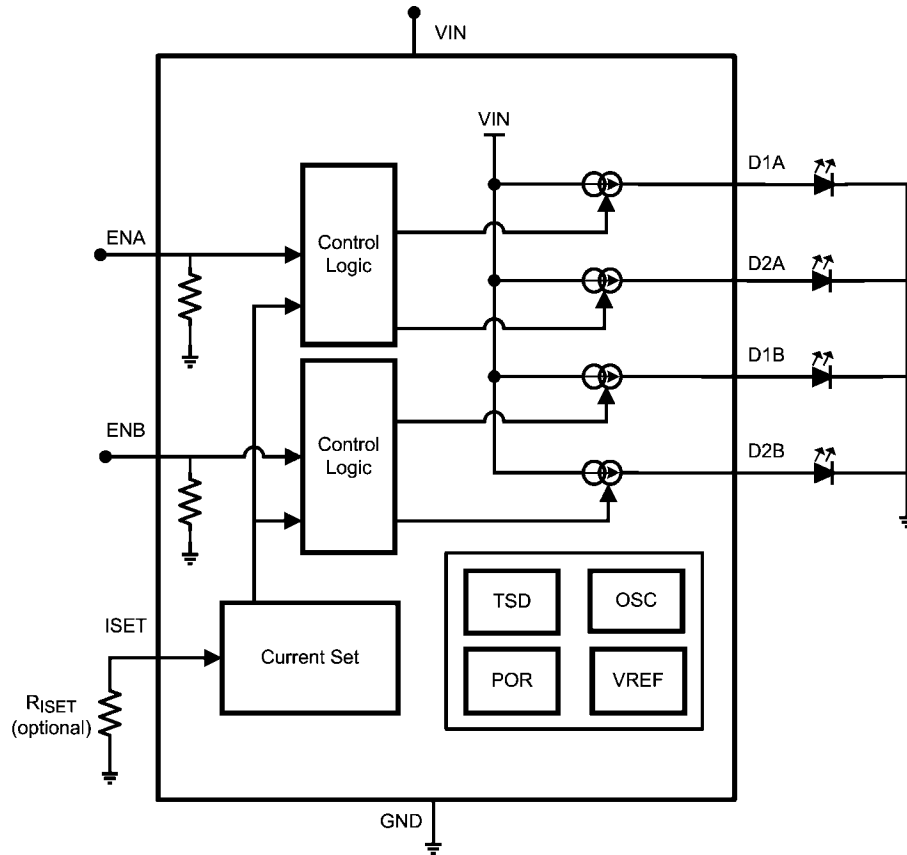

30007636

LED Driver Typical Performance Characteristics

$T_J = 25^\circ\text{C}$. Unless otherwise noted, typical performance characteristics apply to the LP5524 Block Diagram with: $V_{IN} = 3.6\text{V}$, $R_{ISET} = 32.4\text{ k}\Omega$, $C_{IN} = 100\text{ nF}$.

Output Current vs R_{ISET} (Expanded Range)

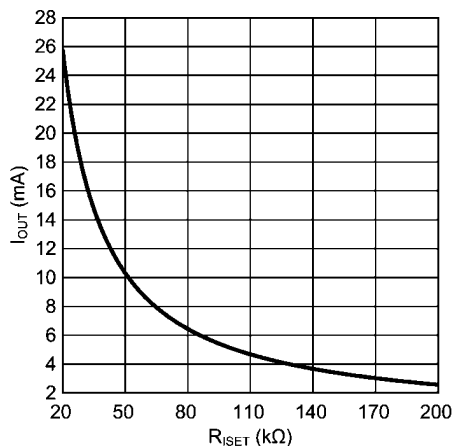

30007622

Output Current vs R_{ISET}

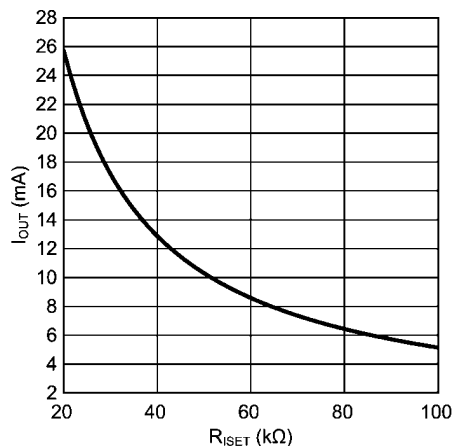

30007623

Output Current vs Input Voltage (ISET Connected To VDD)

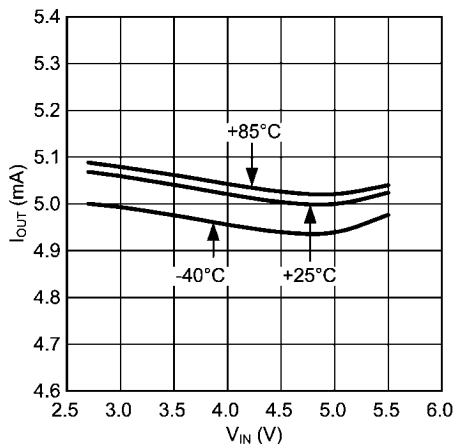

30007624

Output Current vs Headroom Voltage

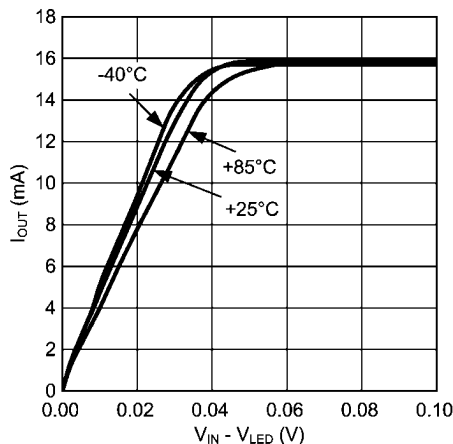

30007625

PWM Response (Both Channels)

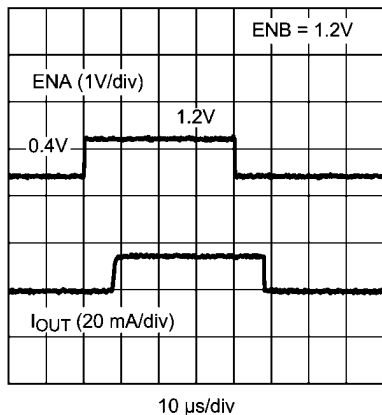

30007629

PWM Response (Single Channel)

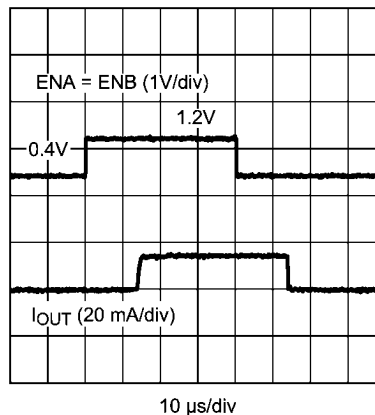

30007627

Application Information

ENABLE MODE

The LP5524 has four constant current LED outputs which are split into two independently controlled banks. Each bank has its own enable input. ENA is used to control bank A and ENB is used to control bank B. Both enables are active high and have internal pull-down resistors. When both enables are low part is in low power standby mode. Driving either enable high will activate the part and corresponding LED outputs.

ISET PIN

An external resistor (R_{ISET}) connected to ISET pin sets the output current of all the LEDs. The internal current mirror sets the LEDs output current with a 416:1 ratio to the current through R_{ISET} . The following equation approximates the LED current:

$$I_{DX} = 515 / R_{ISET} \text{ (Amps)}$$

The use of R_{ISET} is optional. If R_{ISET} is not used ISET pin can be left floating or connected to V_{IN} . In these cases LED current is set to default current.

PWM BRIGHTNESS CONTROL

The brightness of LEDs can be linearly varied from zero up to the maximum programmed current level by applying a Pulse-Width-Modulated signal to the ENx pin of the LP5524. The following procedures illustrate how to program the LED drive current and adjust the output current level using a PWM signal.

1. Determine the maximum desired LED current. Use the I_{DX} equation to calculate R_{ISET} .
2. Brightness control can be implemented by pulsing a signal at the ENx pin. LED brightness is proportional to the duty cycle (D) of the PWM signal.

For linear brightness control over the full duty cycle adjustment range, the LP5524 uses a special turn-off time delay to compensate the turn-on time of the device.

If the PWM frequency is much less than 100Hz, flicker may be seen in the LEDs. For the LP5524, zero duty cycle will turn off the LEDs and a 50% duty cycle will result in an average I_{DX} being half of the programmed LED current. For example, if R_{ISET} is set to program LED current to 15 mA, a 50% duty cycle will result in an average I_{DX} of 7.5mA.

LED HEADROOM VOLTAGE

A single current source is connected internally between V_{IN} and DX outputs (D1A, D2A, D1B and D2B). The voltage across the current source, ($V_{IN} - V_{DX}$), is referred to as headroom voltage (V_{HR}). The current source requires a sufficient amount of headroom voltage to be present across it in order to regulate properly.

Figure Output Current vs Headroom Voltage shows how output current of the LP5524 varies with respect to headroom voltage. On the flat part of the graph, the current is regulated properly as there is sufficient headroom voltage for regulation. On the sloping part of the graph the headroom voltage is too small, the current source is squeezed, and the current drive capability is limited. Thus, operating the LP5524 with insufficient headroom voltage across the current source should be avoided.

LED OUTPUTS

If more than 25 mA of output current is required LED outputs can be connected parallel. Connecting LED outputs of different group parallel generates a simply two stage brightness control. With I_{DX} set to 25 mA, enabling one group sets the LED current to 25 mA. Enabling second bank increases the LED current to 50 mA. Unused LED outputs can be left floating or tied to V_{IN} .

Recommended External Components

INPUT CAPACITOR, C_{IN}

Although not required for normal operation, a capacitor can be added to V_{IN} to reduce line noise. A surface-mount multi-layer ceramic capacitor (MLCC) is recommended. MLCCs with a X7R or X5R temperature characteristic are preferred.

CURRENT SET RESISTOR, R_{ISET}

If other than 5 mA current is required, R_{ISET} resistor can be used to adjust the current. For 15.9 mA current 32.4 k Ω re-

sistor is required. Accuracy of the resistor directly effects to the accuracy of the LED current. 1% or better is recommended.

LED

Forward voltage of LED must be less than minimum input voltage minus minimum headroom voltage (V_{HR}). For example with 2.7V input voltage and 20 mA LED current the maximum LED forward voltage is 2.7V - 100 mV = 2.6V.

List of Recommended External Components

Symbol	Symbol Explanation	Value	Unit	Type
C_{IN}	VDD Bypass Capacitor	100	nF	Ceramic, X7R or X5R
R_{ISET}	Current Set Resistor for 15.9 mA LED Current	32.4	k Ω	1%
LEDs		User defined		

Recommended E96 Series (1% Tolerance) Current Set Resistors

R_{ISET} (k Ω)	I_{DX} (mA)	R_{ISET} (k Ω)	I_{DX} (mA)
169	3.0	34.0	15.1
127	4.1	32.4	15.9
102	5.0	30.1	17.1
84.5	6.1	28.7	17.9
73.2	7.0	26.7	19.3
64.9	7.9	25.5	20.2
56.2	9.2	24.3	21.2
51.1	10.1	23.2	22.2
46.4	11.1	22.1	23.3
42.2	12.2	21.5	24.0
39.2	13.1	20.5	25.1
36.5	14.1		

$$I_{DX} = 515 / R_{ISET} \text{ (Amps)}$$

Physical Dimensions inches (millimeters) unless otherwise noted

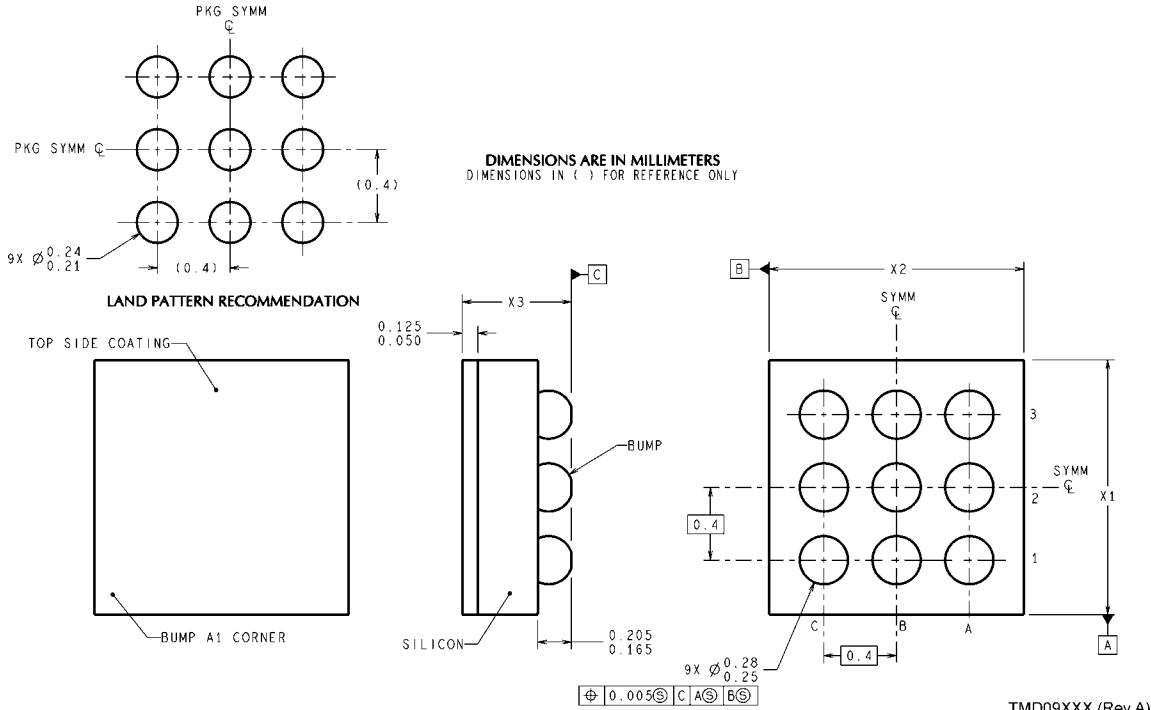

TMD09XXX (Rev A)

The dimension for X1, X2 and X3 are as given:

- X1 = 1.215 mm ±0.03 mm
- X2 = 1.215 mm ±0.03 mm
- X3 = 0.60 mm ±0.075 mm

NS Package Number TMD09AAA
microSMD-9

See National Semiconductor Application Note 1112 Micro SMD Wafer Level Chip Scale Package for PCB design and assembly instructions.

Notes

Notes

THE CONTENTS OF THIS DOCUMENT ARE PROVIDED IN CONNECTION WITH NATIONAL SEMICONDUCTOR CORPORATION ("NATIONAL") PRODUCTS. NATIONAL MAKES NO REPRESENTATIONS OR WARRANTIES WITH RESPECT TO THE ACCURACY OR COMPLETENESS OF THE CONTENTS OF THIS PUBLICATION AND RESERVES THE RIGHT TO MAKE CHANGES TO SPECIFICATIONS AND PRODUCT DESCRIPTIONS AT ANY TIME WITHOUT NOTICE. NO LICENSE, WHETHER EXPRESS, IMPLIED, ARISING BY ESTOPPEL OR OTHERWISE, TO ANY INTELLECTUAL PROPERTY RIGHTS IS GRANTED BY THIS DOCUMENT.

TESTING AND OTHER QUALITY CONTROLS ARE USED TO THE EXTENT NATIONAL DEEMS NECESSARY TO SUPPORT NATIONAL'S PRODUCT WARRANTY. EXCEPT WHERE MANDATED BY GOVERNMENT REQUIREMENTS, TESTING OF ALL PARAMETERS OF EACH PRODUCT IS NOT NECESSARILY PERFORMED. NATIONAL ASSUMES NO LIABILITY FOR APPLICATIONS ASSISTANCE OR BUYER PRODUCT DESIGN. BUYERS ARE RESPONSIBLE FOR THEIR PRODUCTS AND APPLICATIONS USING NATIONAL COMPONENTS. PRIOR TO USING OR DISTRIBUTING ANY PRODUCTS THAT INCLUDE NATIONAL COMPONENTS, BUYERS SHOULD PROVIDE ADEQUATE DESIGN, TESTING AND OPERATING SAFEGUARDS.

EXCEPT AS PROVIDED IN NATIONAL'S TERMS AND CONDITIONS OF SALE FOR SUCH PRODUCTS, NATIONAL ASSUMES NO LIABILITY WHATSOEVER, AND NATIONAL DISCLAIMS ANY EXPRESS OR IMPLIED WARRANTY RELATING TO THE SALE AND/OR USE OF NATIONAL PRODUCTS INCLUDING LIABILITY OR WARRANTIES RELATING TO FITNESS FOR A PARTICULAR PURPOSE, MERCHANTABILITY, OR INFRINGEMENT OF ANY PATENT, COPYRIGHT OR OTHER INTELLECTUAL PROPERTY RIGHT.

LIFE SUPPORT POLICY

NATIONAL'S PRODUCTS ARE NOT AUTHORIZED FOR USE AS CRITICAL COMPONENTS IN LIFE SUPPORT DEVICES OR SYSTEMS WITHOUT THE EXPRESS PRIOR WRITTEN APPROVAL OF THE CHIEF EXECUTIVE OFFICER AND GENERAL COUNSEL OF NATIONAL SEMICONDUCTOR CORPORATION. As used herein:

Life support devices or systems are devices which (a) are intended for surgical implant into the body, or (b) support or sustain life and whose failure to perform when properly used in accordance with instructions for use provided in the labeling can be reasonably expected to result in a significant injury to the user. A critical component is any component in a life support device or system whose failure to perform can be reasonably expected to cause the failure of the life support device or system or to affect its safety or effectiveness.

National Semiconductor and the National Semiconductor logo are registered trademarks of National Semiconductor Corporation. All other brand or product names may be trademarks or registered trademarks of their respective holders.

Copyright© 2007 National Semiconductor Corporation

For the most current product information visit us at www.national.com



National Semiconductor Americas Customer Support Center
 Email: new.feedback@nsc.com
 Tel: 1-800-272-9959

National Semiconductor Europe Customer Support Center
 Fax: +49 (0) 180-530-85-86
 Email: europe.support@nsc.com
 Deutsch Tel: +49 (0) 69 9508 6208
 English Tel: +49 (0) 870 24 0 2171
 Français Tel: +33 (0) 1 41 91 8790

National Semiconductor Asia Pacific Customer Support Center
 Email: ap.support@nsc.com

National Semiconductor Japan Customer Support Center
 Fax: 81-3-5639-7507
 Email: jpn.feedback@nsc.com
 Tel: 81-3-5639-7560