

LP5553 PowerWise® AVS Energy Management Unit with SPMI

Check for Samples: [LP5553](#)

FEATURES

- **SPMI Bus for System-Level Power Management**
- **High-Efficiency PowerWise® Technology Adaptive Voltage Scaling for Intelligent Energy Management in AVS and DVS Environments**
- **Two Digitally Programmable 3.6 MHz Buck Regulators to Power Dual Voltage Domains**
- **Five Programmable LDOs for System Functions Such as:**
 - **PLL/Clock Generation**
 - **I/O**
 - **Memory Retention**
- **Internal Soft Start**
- **Variable Regulator Power Up Sequencing.**

KEY SPECIFICATIONS

- **Input Voltage Range: 2.7 to 4.8V**
- **Output Voltage Range: $\pm 2\%$ (typical)**
- **Programmable DC/DC Buck Converters**
 - **Output Current per DC/DC Converter: 800 mA**
 - **Efficiency: Up to 88%**
 - **Digitally Programmable: from 0.6 to 1.235V**
- **Programmable LDOs**
 - **Five digitally programmable LDOs**

APPLICATIONS

- **GSM/GPRS/EDGE & UMTS Cellular Handsets**
- **Hand-Held Radios**
- **PDA's**
- **Battery Powered Devices**
- **Portable Instruments**



These devices have limited built-in ESD protection. The leads should be shorted together or the device placed in conductive foam during storage or handling to prevent electrostatic damage to the MOS gates.

DESCRIPTION

The LP5553 is a System Power Management Interface (SPMI) compliant Energy Management Unit for reducing power consumption of low power hand held applications such as dual-core processors and DSPs.

The LP5553 contains 2 advanced, digitally controlled step-down DC/DC converters for supplying variable voltages to a SoC. The device also incorporates 5 programmable low-dropout, low noise linear regulators for powering I/O, peripheral logic blocks, auxiliary system functions, and maintaining memory retention (dual-domain) in shutdown-mode.

The LP5553 implements 2 Non-Request Capable Slaves that are controlled via the SPMI. The LP5553 operates cooperatively with PowerWise® AVS technology compatible processors to optimize supply voltages adaptively (AVS - Adaptive Voltage Scaling) over process and temperature variations. It also supports dynamic voltage scaling (DVS) using frequency/voltage pairs from pre-characterized look-up tables.



Please be aware that an important notice concerning availability, standard warranty, and use in critical applications of Texas Instruments semiconductor products and disclaimers thereto appears at the end of this data sheet.

All trademarks are the property of their respective owners.

System Diagram

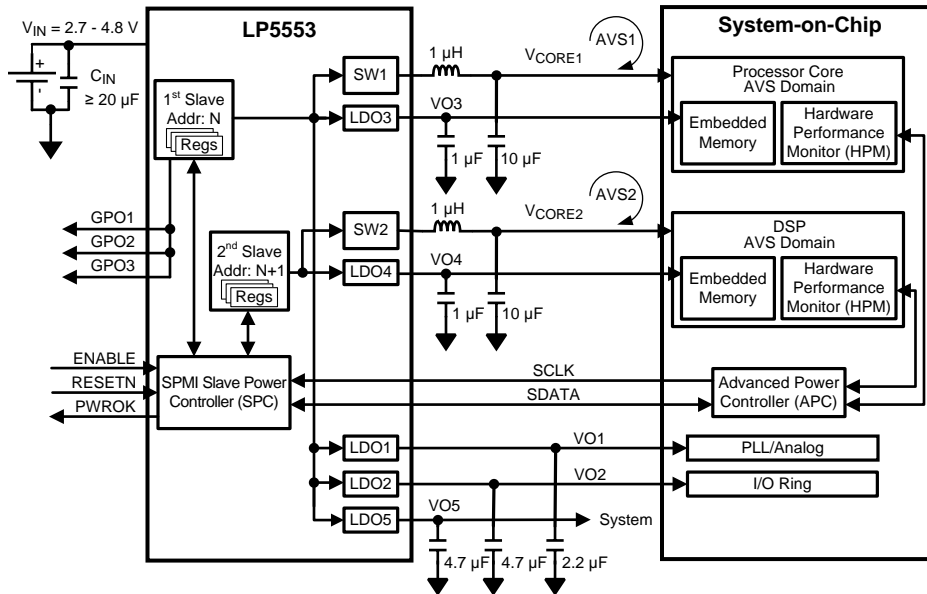

Connection Diagrams and Package Mark Information

**CONNECTION DIAGRAM
LP5553 Pinout (Top View)**

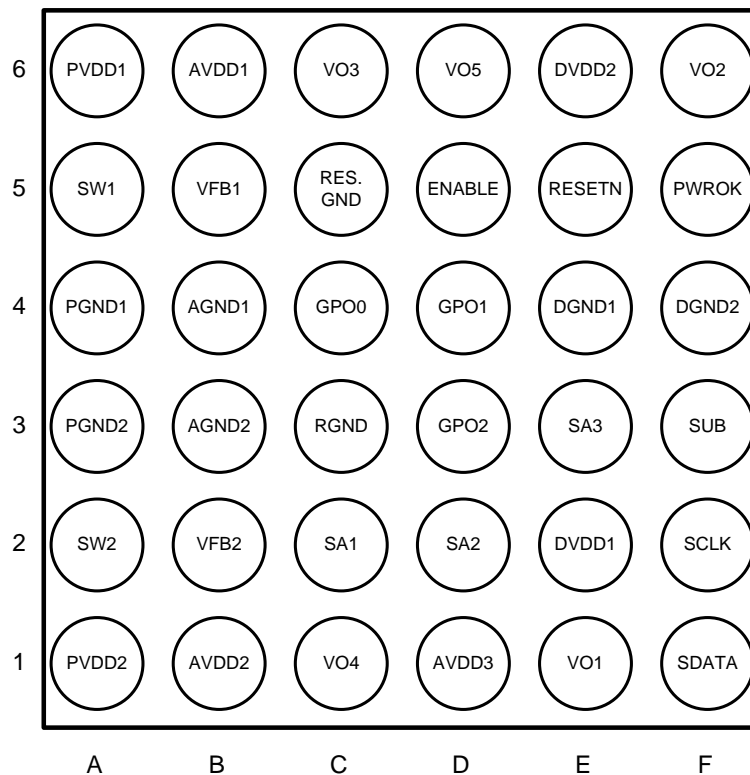

Pin Descriptions

Pin #	Pin Name	I/O ⁽¹⁾	Type ⁽¹⁾	Function
E2	DVDD1	P	P	Power supply voltage input for digital. Connect to V_{IN} .
E6	DVDD2	P	P	Power supply voltage input for digital, LDO2 and LDO5. Connect to V_{IN} .
B6	AVDD1	P	P	Power supply voltage input for analog, switching regulator #1 and LDO3. Connect to V_{IN} .
B1	AVDD2	P	P	Power supply voltage input for analog, switching regulator #2 and LDO4. Connect to V_{IN} .
D1	AVDD3	P	P	Power supply voltage input for analog and LDO1. Connect to V_{IN} .
A6	PVDD1	P	P	Power supply voltage input to internal PFET of switching regulator #1. Connect to V_{IN} .
A1	PVDD2	P	P	Power supply voltage input to internal PFET of switching regulator #2. Connect to V_{IN} .
E4	DGND1	G	G	Digital Ground. Connect to system Ground.
F4	DGND2	G	G	Digital Ground. Connect to system Ground.
B4	AGND1	G	G	Analog Ground. Connect to system Ground.
B3	AGND2	G	G	Analog Ground. Connect to system Ground.
A4	PGND1	G	G	Power Ground. Connect to system Ground.
A3	PGND2	G	G	Power Ground. Connect to system Ground.
F3	SUB	G	G	Substrate Ground. Connect to system Ground.
C3	RGND	G	G	Reference/sense Ground. Should connect to the Ground node of the switching regulators output capacitors.
D5	ENABLE	I	D	Enable input. Set this digital input high for normal operation.
F2	SCLK	I	D	SPMI clock input
F1	SDATA	I/O	D	SPMI bi-directional data
E5	RESETN	I	D	Active low Reset input. Set this digital input high for normal operation.
F5	PWROK	O	D	Power OK indicator. This is a digital, active high output signal.
E1	VO1	P	P	LDO1 output voltage.
F6	VO2	P	P	LDO2 output voltage. SPMI signals SCLK and SDATA reference voltage.
C6	VO3	P	P	LDO3 output voltage. Can be programmed to track V_{CORE1} voltage.
C1	VO4	P	P	LDO4 output voltage. Can be programmed to track V_{CORE2} voltage.
D6	VO5	P	P	LDO5 output voltage.
A5	SW1	P	P	V_{CORE1} Switching node; connected to filter inductor.
A2	SW2	P	P	V_{CORE2} Switching node; connected to filter inductor.
B5	VFB1	I	A	V_{CORE1} DC/DC analog feedback input. Connect to the V_{CORE1} output voltage.
B2	VFB2	I	A	V_{CORE2} DC/DC analog feedback input. Connect to the V_{CORE2} output voltage.
C4	GPO0	O	D/OD	General Purpose Output 0. Can be programmed as a CMOS output referenced to V_{O2} or as an open-drain output to a user selected voltage.
D4	GPO1	O	D/OD	General Purpose Output 1. Can be programmed as a CMOS output referenced to V_{O2} or as an open-drain output to a user selected voltage.
D3	GPO2	O	D/OD	General Purpose Output 2. Can be programmed as a CMOS output referenced to V_{O2} or as an open-drain output to a user selected voltage.
C2	SA1	I	D	SPMI Slave Address Bit 1. Tie to Ground or V_{IN} for 0 or 1, respectively. (Note: SA0 is internal. '0' = Slave(N) = V_{CORE1} ; '1' = Slave(N+1) = V_{CORE2})
D2	SA2	I	D	SPMI Slave Address Bit 2. Tie to Ground or V_{IN} for 0 or 1, respectively.
E3	SA3	I	D	SPMI Slave Address Bit 3 (MSB). Tie to Ground or V_{IN} for 0 or 1, respectively.
C5	Reserved	G	G	Must be tied to Ground. Failure to do so may result in undefined behavior.

(1) A: Analog Pin; D: Digital Pin; G: Ground Pin; P: Power Pin; I: Input Pin; I/O: Input/Output Pin; O: Output Pin; OD: Open Drain Output Pin

Absolute Maximum Ratings (1) (2)(3)

V_{IN} pins (All V_{DD} pins)	-0.3V to +6.0V
SW1, SW2, V_{O1} , V_{O2} , V_{O3} , V_{O4} , V_{O5} to GND	-0.3V to ($V_{IN} + 0.3V$)
ENABLE, RESETN, SCLK, SA1, SA2, SA3	-0.3V to ($V_{IN} + 0.3V$)
SDATA, PWROK, V_{FB1} , V_{FB2} , GPO0, GPO1, GPO2	-0.3V to ($V_{IN} + 0.3V$)
Junction Temperature (T_{J-MAX})	150°C
Storage Temperature Range	-65°C to +150°C
Max Continuous Power Dissipation P_{D-MAX} (4) (5)	Internally limited
Maximum Lead Temperature (Soldering 10 seconds)	+260°C

- (1) Absolute Maximum Ratings are limits beyond which damage to the device may occur. Operating Ratings are conditions under which operation of the device is ensured. Operating Ratings do not imply ensured performance limits. For ensured performance limits and associated test conditions, see the Electrical Characteristics tables.
- (2) All voltages are with respect to the potential at the GND pin.
- (3) If Military/Aerospace specified devices are required, please contact the TI Sales Office/ Distributors for availability and specifications.
- (4) The Absolute Maximum power dissipation depends on the ambient temperature and can be calculated using the formula $P = (T_J - T_A) / \theta_{JA}$ where T_J is the junction temperature, T_A is the ambient temperature and θ_{JA} is the junction-to-ambient thermal resistance. Junction-to-ambient thermal resistance is highly application and board-layout dependent. In applications where high maximum power dissipation exists, special care must be paid to thermal dissipation issues in board design.
- (5) Internal thermal shutdown circuitry protects the device from permanent damage. Thermal shutdown engages at $T_J = 150^\circ\text{C}$ (typ.) and disengages at $T_J = 140^\circ\text{C}$ (typ.).

ESD Ratings (1)

All pins	2 kv HBM
	200V MM

- (1) The human-body model is 100 pF discharged through 1.5 k Ω . The machine model is a 200 pF capacitor discharged directly into each pin, MIL-STD-883 3015.7.

Operating Ratings (1) (2)

Input voltage range V_{IN}	2.7 to 4.8V
ENABLE, RESETN, PWROK	0V to V_{IN}
SDATA, SCLK	0V to V_{O2}
SA1, SA2, SA3	0V to V_{IN}

- (1) Absolute Maximum Ratings are limits beyond which damage to the device may occur. Operating Ratings are conditions under which operation of the device is ensured. Operating Ratings do not imply ensured performance limits. For ensured performance limits and associated test conditions, see the Electrical Characteristics tables.
- (2) All voltages are with respect to the potential at the GND pin.

Thermal Properties⁽¹⁾

Junction Temperature (T_J)	-40°C to +125°C
Ambient Temperature (T_A) ⁽²⁾	-40°C to +85°C
Junction-to-Ambient Thermal Resistance (θ_{JA}) ⁽³⁾	60°C/W

- (1) In applications where high power dissipation and/or poor package thermal resistance is present, the maximum ambient temperature may have to be derated. Maximum ambient temperature (T_{A-MAX}) is dependent on the maximum operating junction temperature ($T_{J-MAX-OP} = 125^\circ\text{C}$), the maximum power dissipation of the device in the application (P_{D-MAX}) and the junction-to ambient thermal resistance of the part/package in the application (θ_{JA}), as given by the following equation: $T_{A-MAX} = T_{J-MAX-OP} - (\theta_{JA} \times P_{D-MAX})$.
- (2) All limits are ensured by design, test and/or statistical analysis. All electrical characteristics having room-temperature limits are tested during production with $T_J = 25^\circ\text{C}$. All hot and cold limits are ensured by correlating the electrical characteristics to process and temperature variations and applying statistical process control.
- (3) Junction-to-ambient thermal resistance (θ_{JA}) is taken from a thermal modeling result, performed under the conditions and guidelines set forth in the JEDEC standard JESD51-7. The test board is a 4-layer FR-4 board measuring 102 mm x 76 mm x 1.6 mm with a 2x1 array of thermal vias. The ground plane on the board is 50 mm x 50 mm. Thickness of copper layers are 36 μm / 18 μm / 18 μm / 36 μm (1.5 oz / 1 oz / 1 oz / 1.5 oz). Ambient temperature in simulation is 22°C, still air. Power dissipation is 1W. Junction-to-ambient thermal resistance is highly application and board-layout dependent. In applications where high maximum power dissipation exists, special care must be paid to thermal dissipation issues in board design. The value of θ_{JA} of this product can vary significantly, depending on PCB material, layout and environmental conditions. In applications where high maximum power dissipation exists (high V_{IN} , high I_{OUT}), special care must be paid to thermal dissipation issues. For more information on these topics, please refer to *Application Note 1112: Micro SMD Wafer Level Chip Scale Package SNVA009* and the [Board Layout Considerations](#) section of this datasheet.

General Electrical Characteristics⁽¹⁾ ⁽²⁾ ⁽³⁾

Unless otherwise noted, $V_{IN} = 3.6\text{V}$. Typical values and limits appearing in normal type apply for $T_J = 25^\circ\text{C}$. Limits appearing in **boldface** type apply over the entire junction temperature range for operation, $-40^\circ\text{C} \leq T_J \leq +125^\circ\text{C}$.

Symbol	Parameter	Conditions	Min	TYP	Max	Units
I_Q	Shutdown Supply Current	All circuits off; $-40^\circ\text{C} \leq T_A = T_J \leq +125^\circ\text{C}$		1	75	μA
	Memory retention current in Deep Sleep (i.e., both slaves in Sleep state)	V_{CORE1} and V_{CORE2} in Sleep state; V_{O1} , V_{O2} and V_{O5} on, but unloaded; V_{O3} and V_{O4} in low I_Q		130	350	
	No load supply current	All regulators active and unloaded; switching regulators in Burst-PWM		735	930	
UVLO-high	Under Voltage Lockout, high threshold			2.6	2.7	V
UVLO-low	Under Voltage Lockout, low threshold		2.5	2.6		V
Thermal Shutdown						
TSD	Threshold ⁽⁴⁾ Hysteresis ⁽⁴⁾		160 20			$^\circ\text{C}$
Logic and Control Inputs						
V_{IL}	Logic Input Low	ENABLE, RESETN, SDATA, SCLK $2.7\text{V} \leq V_{IN} \leq 4.8\text{V}$			0.2	V
$V_{IH-SIDEBAND}$	Logic Input High	ENABLE, RESETN $2.7\text{V} \leq V_{IN} \leq 4.8\text{V}$	2.0			V
$V_{IH-SPMI}$	Logic Input High	SDATA, SCLK $1.5\text{V} \leq V_{O2} \leq 3.3\text{V}$	$V_{O2} - 0.2$			V
I_{IL}	Input Leakage Current	ENABLE, RESETN $2.7\text{V} \leq V_{IN} \leq 4.8\text{V}$	-1		+1	μA
	Input Leakage Current (Note: Largely due to pull-down resistors)	SDATA, SCLK $1.5\text{V} \leq V_{O2} \leq 3.3\text{V}$	-1		+5	
$R_{PD-SPMI}$	Pull-down resistance for SPMI signals	SDATA, SCLK	0.5	1	2	M Ω

- (1) All voltages are with respect to the potential at the GND pin.
- (2) All limits are ensured by design, test and/or statistical analysis. All electrical characteristics having room-temperature limits are tested during production with $T_J = 25^\circ\text{C}$. All hot and cold limits are ensured by correlating the electrical characteristics to process and temperature variations and applying statistical process control.
- (3) Capacitors: Low-ESR Surface-Mount Ceramic Capacitors are (MLCCs) used in setting electrical characteristics
- (4) ensured specifically by design.

General Electrical Characteristics ⁽¹⁾ ⁽²⁾ ⁽³⁾ (continued)

Unless otherwise noted, $V_{IN} = 3.6V$. Typical values and limits appearing in normal type apply for $T_J = 25^\circ C$. Limits appearing in **boldface** type apply over the entire junction temperature range for operation, $-40^\circ C \leq T_J \leq +125^\circ C$.

Symbol	Parameter	Conditions	Min	TYP	Max	Units
Logic and Control Outputs						
V_{OL}	Logic Output Low	PWROK, SDATA, GPOx $I_{SINK} \leq 1 \text{ mA}$			0.4	V
$V_{OH-SIDEBAND}$	Logic Output High	PWROK $I_{SOURCE} \leq 1 \text{ mA}$	$V_{IN} - 0.4$			V
$V_{OH-SPMI}$	Logic Output High	SDATA $I_{SOURCE} \leq 1 \text{ mA}$	$V_{O2} - 0.4$			V
$V_{OH-GPOX}$	Logic Output High	GPOx, GPOs set for CMOS out $I_{SOURCE} \leq 1 \text{ mA}$	$V_{O2} - 0.4$			V
$V_{OD-GPOX}$	Maximum Open-Drain High Voltage	GPOx			$V_{IN} + 0.3$	V
I_{GPO}	GPO Source/Sink Current			1		mA
T_{ENL}	Minimum ENABLE low pulse time		100			ns
T_{RSTL}	Minimum RESETN low pulse time		100			ns

Output Specification ⁽¹⁾ ⁽²⁾

Supply	Output Voltage Range (V)	Default Output Voltage (V)	Output Voltage Resolution (mV)	I_{MAX} Maximum Output Current (mA)	Typical Application
V_{CORE1}	0.6 to 1.235	1.235	5	800	Voltage Scaling Domain 1
V_{CORE2}	0.6 to 1.235	1.235	5	800	Voltage Scaling Domain 2
LDO1	0.7 to 2.2	1.2	100	100	PLL/Fixed Logic
LDO2	1.5 to 3.3	3.3	100-300	250	I/O Voltage
LDO3	0.6 to 1.35	1.25	50	50	Embedded Memory Domain 1
LDO4	0.6 to 1.35	1.25	50	50	Embedded Memory Domain 2
LDO5	1.2 to 3.3	3.3	100-300	250	Peripheral(s)

(1) All voltages are with respect to the potential at the GND pin.

(2) Capacitors: Low-ESR Surface-Mount Ceramic Capacitors are (MLCCs) used in setting electrical characteristics

$V_{\text{CORE1}}/V_{\text{CORE2}}$ DC/DC Converters 1 and 2 Output Voltage Characteristics

Unless otherwise noted, $V_{\text{IN}} = 3.6\text{V}$. Typical values and limits appearing in normal type apply for $T_J = 25^\circ\text{C}$. Limits appearing in **boldface** type apply over the entire junction temperature range for operation, -40°C to $+125^\circ\text{C}$. ⁽¹⁾ ⁽²⁾ ⁽³⁾

Symbol	Parameter	Conditions	Min	Typ	Max	Units
V_{OUT} Accuracy	Output voltage, Static accuracy	$0.65\text{V} \leq V_{\text{OUT}} \leq 1.235\text{V}$ $I_{\text{OUT}} = 0 - 800\text{ mA}$	-2		+2	%
	Output voltage, Static accuracy	$0.60\text{V} \leq V_{\text{OUT}} \leq 0.65\text{V}$ $I_{\text{OUT}} = 0 - 800\text{ mA}$	-4		+4	%
V_{OUT} Range	Programmable Output Voltage Range	$0\text{mA} \leq I_{\text{OUT}} \leq 800\text{ mA}$	0.6	1.235(def ault)	1.235	V
ΔV_{OUT}	Line regulation	$2.7\text{V} \leq V_{\text{IN}} \leq 4.8\text{V}$, $I_{\text{OUT}} = 100\text{ mA}$		0.05		%/V
	Load regulation	$I_{\text{OUT}} = 100 - 800\text{ mA}$		0.001		%/mA
T_{SCALING}	V_{OUT} Setting Time	From min to max output voltage $I_{\text{OUT}} = 400\text{ mA}$			30	μs
I_{Q}	Quiescent current	No Load, Burst-PWM Mode		325		μA
$R_{\text{DS-ON(P)}}$	P-FET resistance	$V_{\text{IN}} = V_{\text{SG}} = 3.6\text{V}$		255		$\text{m}\Omega$
$R_{\text{DS-ON(N)}}$	N-FET resistance	$V_{\text{IN}} = V_{\text{GS}} = 3.6\text{V}$		135		$\text{m}\Omega$
I_{OUT}	Continuous load current		0		800	mA
I_{LIM}	Peak switching current limit		850	1200	1560	mA
η	Efficiency peak	$I_{\text{OUT}} = 200\text{ mA}$, $V_{\text{IN}} = 2.7\text{V}$, $V_{\text{COREx}} = 1.235\text{V}$		88		%
f_{OSC}	Oscillator frequency	PWM-mode	3.45	3.6	3.75	MHz
C_{OUT}	Output Filter Capacitance	$0\text{ mA} \leq I_{\text{OUT}} \leq 800\text{ mA}$	7	10	13	μF
	Output Capacitor ESR		0		20	$\text{m}\Omega$
L	Output Filter Inductance	$0\text{ mA} \leq I_{\text{OUT}} \leq 800\text{ mA}$	0.7	1.0	1.3	μH
t_{SS}	Soft start ramp time			120		μs
$t_{\text{START-UP}}$	Start-Up Time from V_{COREx} enable to V_{OUT}	$V_{\text{COREx}} = 1.235\text{V}$, unloaded		200		μs

- (1) All voltages are with respect to the potential at the GND pin.
- (2) All limits are ensured by design, test and/or statistical analysis. All electrical characteristics having room-temperature limits are tested during production with $T_J = 25^\circ\text{C}$. All hot and cold limits are ensured by correlating the electrical characteristics to process and temperature variations and applying statistical process control.
- (3) Capacitors: Low-ESR Surface-Mount Ceramic Capacitors are (MLCCs) used in setting electrical characteristics

V_{O1} LDO1 Output Voltage Characteristics

Unless otherwise noted, V_{IN} = 3.6V, V_{OUT} = 1.2V (default). Typical values and limits appearing in normal type apply for T_J = 25°C. Limits appearing in **boldface** type apply over the full operating junction temperature range, -40° to +125°C.^{(1) (2) (3)}

Symbol	Parameter	Conditions	Min	Typ	Max	Units
V _{OUT} Accuracy	Output Voltage	1 mA ≤ I _{OUT} ≤ 100 mA, 2.7V ≤ V _{IN} ≤ 4.8V	-2		2	%
V _{OUT} Range	Programmable Output Voltage Range	0 mA ≤ I _{OUT} ≤ 100 mA 16 steps of 100 mV	0.7	1.2(default)	2.2	V
I _{OUT}	Output Current	2.7V ≤ V _{IN} ≤ 4.8V			100	mA
	Output Current Limit	V _{O1} = 0V (i.e., tied to Ground)			400	
I _Q	Quiescent Current ⁽⁴⁾	I _{OUT} = 50 mA		19		μA
ΔV _{OUT}	Line Regulation	2.7V ≤ V _{IN} ≤ 4.8V I _{OUT} = 50 mA	-0.1		0.1	%/V
	Load Regulation	1 mA ≤ I _{OUT} ≤ 100 mA	-0.005		0.005	%/mA
	Line Transient Regulation	V _{IN} = 3.9V → 3.6V → 3.9V T _{RISE} = T _{FALL} = 10 μs		10		mV
	Load Transient Regulation	V _{IN} = 3.6V I _{OUT} = 10 mA → 90 mA → 10 mA T _{RISE} = T _{FALL} = 10 μs		60		mV
e _N	Output Noise Voltage	10 Hz ≤ f ≤ 100 kHz C _{OUT} = 2.2 μF		100		μV _{RMS}
PSRR	Power Supply Ripple Rejection Ratio	f = 1 kHz C _{OUT} = 2.2 μF		50		dB
		f = 10 kHz C _{OUT} = 2.2 μF		40		dB
C _{OUT}	Output Capacitance	0 mA ≤ I _{OUT} ≤ 100 mA	1	2.2	20	μF
	Output Capacitor ESR		5		500	mΩ
t _{START-UP}	Start-Up Time from LDO1 enable	C _{OUT} = 2.2 μF, I _{OUT} = 100 mA		50		μs

- (1) All voltages are with respect to the potential at the GND pin.
- (2) All limits are ensured by design, test and/or statistical analysis. All electrical characteristics having room-temperature limits are tested during production with T_J = 25°C. All hot and cold limits are ensured by correlating the electrical characteristics to process and temperature variations and applying statistical process control.
- (3) Capacitors: Low-ESR Surface-Mount Ceramic Capacitors are (MLCCs) used in setting electrical characteristics
- (4) Quiescent currents for LDO1 through LDO5 do not include shared blocks such as the bandgap reference.

V_{O2} LDO2 (I/O Voltage) Output Voltage Characteristics

Unless otherwise noted, V_{IN} = 3.6V, I_{OUT} = 125 mA, V_{O2} = 3.3V. Typical values and limits appearing in normal type apply for T_J = 25°C. Limits appearing in **boldface** type apply over the full operating junction temperature range, -40 to +125°C. ⁽¹⁾ ⁽²⁾ ⁽³⁾

Symbol	Parameter	Conditions	Min	Typ	Max	Units
V _{OUT} Accuracy	Output Voltage	1 mA ≤ I _{OUT} ≤ 250 mA, 3.6V ≤ V _{IN} ≤ 4.8V	-2		2	%
V _{OUT} Range	Programmable Output Voltage Range	1.5 through 2.3 in 100 mV steps, 2.5, 2.8, 3.0V and 3.3V	1.5	3.3(default)	3.3	V
I _{OUT}	Output Current	(V _{O2} + 0.4V) ≤ V _{IN} ≤ 4.8V			250	mA
	Output Current Limit	V _{O2} = 0V (i.e., tied to Ground)			800	
V _{IN} - V _{O2}	Dropout Voltage ⁽⁴⁾	I _{OUT} = 125 mA		70	260	mV
I _Q	Quiescent Current ⁽⁵⁾	I _{OUT} = 125 mA		19		μA
ΔV _{OUT}	Line Regulation	(V _{O2} + 0.4V) ≤ V _{IN} ≤ 4.8V I _{OUT} = 125 mA	-0.1		0.1	%/V
	Load Regulation	V _{IN} = 3.6V 1 mA ≤ I _{OUT} ≤ 250 mA	-0.005		+0.005	%/mA
	Line Transient Regulation ⁽⁶⁾	V _{IN} = 4.0V → 3.6V → 4.0V V _{O2} = 3.3V T _{RISE} = T _{FALL} = 10 μs		10		mV
	Load Transient Regulation	V _{IN} = 3.6V I _{OUT} = 25 mA → 225 mA → 25 mA T _{RISE} = T _{FALL} = 1 μs		125		mV
PSRR	Power Supply Ripple Rejection Ratio	f = 1 kHz C _{OUT} = 4.7 μF		55		dB
		f = 10 kHz C _{OUT} = 4.7 μF		40		dB
C _{OUT}	Output Capacitance	0 mA ≤ I _{OUT} ≤ 250 mA	2	4.7	20	μF
	Output Capacitor ESR		5		500	mΩ
t _{START-UP}	Start-Up Time from LDO2 enable	C _{OUT} = 4.7 μF, I _{OUT} = 250 mA		50		μs

- (1) All voltages are with respect to the potential at the GND pin.
- (2) All limits are ensured by design, test and/or statistical analysis. All electrical characteristics having room-temperature limits are tested during production with T_J = 25°C. All hot and cold limits are ensured by correlating the electrical characteristics to process and temperature variations and applying statistical process control.
- (3) Capacitors: Low-ESR Surface-Mount Ceramic Capacitors are (MLCCs) used in setting electrical characteristics
- (4) Dropout voltage is the input-to-output voltage difference at which the output voltage is 100 mV below its nominal value. Other parameters are not ensured when the LDO is in dropout. This specification applies only when the output voltage is greater than 2.7V.
- (5) Quiescent currents for LDO1 through LDO5 do not include shared blocks such as the bandgap reference.
- (6) V_{IN} for line transient is above the default 3.6V to allow for 400 mV of headroom from V_{IN} to V_{OUT}

V_{O3}/V_{O3} LDO3 and LDO4 Output Voltage Characteristics

Unless otherwise noted, $V_{IN} = 3.6V$. Typical values and limits appearing in normal type apply for $T_J = 25^\circ C$. Limits appearing in **boldface** type apply over the full operating junction temperature range, -40 to $+125^\circ C$. ⁽¹⁾ ⁽²⁾ ⁽³⁾

Symbol	Parameter	Conditions	Min	Typ	Max	Units
V_{OUT} Accuracy	Active/Independent, High I_Q	$I_{OUT} \leq 50$ mA, $2.7V \leq V_{IN} \leq 4.8V$ Low I_Q bit is cleared	-2.5		2.5	%
	Active/Independent, Low I_Q	$I_{OUT} \leq 5$ mA, $2.7V \leq V_{IN} \leq 4.8V$ Low I_Q bit is cleared	-2.5		2.5	
V_{OFFSET}	Active state offset from tracked V_{CORE} Offset = $V_{O3} - V_{FB1}$ Offset = $V_{O4} - V_{FB2}$	0 mA $\leq I_{OUT} \leq 50$ mA, $V_{FB} = 0.9V$ $2.7V \leq V_{IN} \leq 4.8V$	0	25	70	mV
V_{OUT} Range	Programmable Output Voltage Range	16 steps of 50 mV	0.6	1.25 (default)	1.35	V
I_Q	Quiescent Current ⁽⁴⁾	Active state/Tracking mode $I_{OUT} = 10$ μ A Low I_Q bit is set		35		μ A
		Sleep state or Active/Independent mode $I_{OUT} = 10$ μ A Low I_Q bit is set		10		
I_{OUT}	Output Current Low I_Q bit is cleared	$2.7V \leq V_{IN} \leq 4.8V$		50		mA
	Output Current Limit Active state/Tracking, Low I_Q bit is set	$2.7V \leq V_{IN} \leq 4.8V$		50		
	Quiescent Current Sleep state/Tracking, Low I_Q bit is set	$2.7V \leq V_{IN} \leq 4.8V$		5		
	Output Current, Independent, Low I_Q bit is set	$2.7V \leq V_{IN} \leq 4.8V$		5		
	Output Current Limit	$V_{O2} = 0V$ (i.e., tied to Ground)			420	
PSRR	Power Supply Ripple Rejection Ratio	$f = 1$ kHz $C_{OUT} = 1.0$ μ F		37		dB
C_{OUT}	Output Capacitance	0 mA $\leq I_{OUT} \leq 5$ mA	0.75	1.0	2.2	μ F
	Output Capacitor ESR		5		500	m Ω
$t_{START-UP}$	Start-Up Time from LDOx enable	$C_{OUT} = 1.0$ μ F, $I_{OUT} = 20$ mA		50		μ s

(1) All voltages are with respect to the potential at the GND pin.

(2) All limits are ensured by design, test and/or statistical analysis. All electrical characteristics having room-temperature limits are tested during production with $T_J = 25^\circ C$. All hot and cold limits are ensured by correlating the electrical characteristics to process and temperature variations and applying statistical process control.

(3) Capacitors: Low-ESR Surface-Mount Ceramic Capacitors are (MLCCs) used in setting electrical characteristics

(4) Quiescent currents for LDO1 through LDO5 do not include shared blocks such as the bandgap reference.

V_{O5} LDO5 Output Voltage Characteristics

Unless otherwise noted, V_{IN} = 3.6V, I_{OUT} = 125 mA, V_{O2} = 3.3V. Typical values and limits appearing in normal type apply for T_J = 25°C. Limits appearing in **boldface** type apply over the full operating junction temperature range, -40 to +125°C. ⁽¹⁾ ⁽²⁾ ⁽³⁾

Symbol	Parameter	Conditions	Min	Typ	Max	Units
V _{OUT} Accuracy	Output Voltage	1 mA ≤ I _{OUT} ≤ 250 mA, V _{O2} = 3.3V 3.6V ≤ V _{IN} ≤ 4.8V	-2		2	%
V _{OUT} Range	Programmable Output Voltage Range	1.2 through 2.3 in 100 mV steps, 2.5, 2.8, 3.0V and 3.3V	1.2	3.3 (default)	3.3	V
I _{OUT}	Output Current	(V _{O5} + 0.4V) ≤ V _{IN} ≤ 4.8V			250	mA
	Output Current Limit	V _{O5} = 0V (i.e., tied to Ground)			800	
V _{IN} - V _{O5}	Dropout Voltage ⁽⁴⁾	I _{OUT} = 125 mA		70	260	mV
I _Q	Quiescent Current ⁽⁵⁾	I _{OUT} = 125 mA		19		μA
ΔV _{OUT}	Line Regulation	(V _{O5} + 0.4V) ≤ V _{IN} ≤ 4.8V I _{OUT} = 125 mA	-0.1		0.1	%/V
	Load Regulation	V _{IN} = 3.6V 1 mA ≤ I _{OUT} ≤ 250 mA	-0.005		0.005	%/mA
	Line Transient Regulation ⁽⁶⁾	V _{IN} = 4.0V → 3.6V → 4.0V V _{O5} = 3.3V T _{RISE} = T _{FALL} = 10 μs		10		mV
	Load Transient Regulation	V _{IN} = 3.6V I _{OUT} = 25 mA → 225 mA → 25 mA T _{RISE} = T _{FALL} = 1 μs		125		mV
PSRR	Power Supply Ripple Rejection Ratio	f = 1 kHz C _{OUT} = 4.7 μF		55		dB
		f = 10 kHz C _{OUT} = 4.7 μF		40		dB
C _{OUT}	Output Capacitance	0 mA ≤ I _{OUT} ≤ 250 mA	2	4.7	20	μF
	Output Capacitor ESR		5		500	mΩ
t _{START-UP}	Start-Up Time from LDO5 enable	C _{OUT} = 4.7 μF, I _{OUT} = 250 mA		50		μs

- (1) All voltages are with respect to the potential at the GND pin.
- (2) All limits are ensured by design, test and/or statistical analysis. All electrical characteristics having room-temperature limits are tested during production with T_J = 25°C. All hot and cold limits are ensured by correlating the electrical characteristics to process and temperature variations and applying statistical process control.
- (3) Capacitors: Low-ESR Surface-Mount Ceramic Capacitors are (MLCCs) used in setting electrical characteristics
- (4) Dropout voltage is the input-to-output voltage difference at which the output voltage is 100 mV below its nominal value. Other parameters are not ensured when the LDO is in dropout. This specification applies only when the output voltage is greater than 2.7V.
- (5) Quiescent currents for LDO1 through LDO5 do not include shared blocks such as the bandgap reference.
- (6) V_{IN} for line transient is above the default 3.6V to allow for 400 mV of headroom from V_{IN} to V_{OUT}

LP5553 - Typical Performance Characteristics

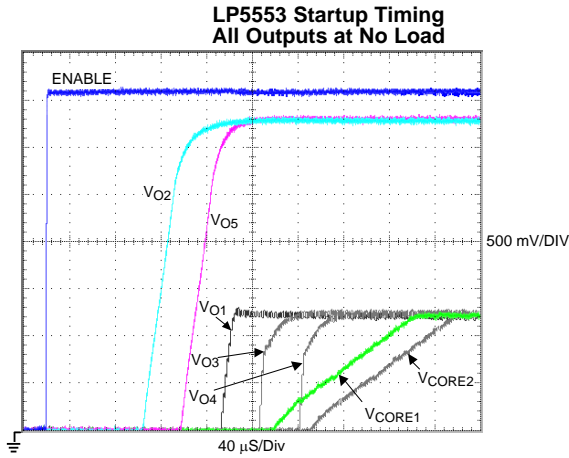

Figure 1.

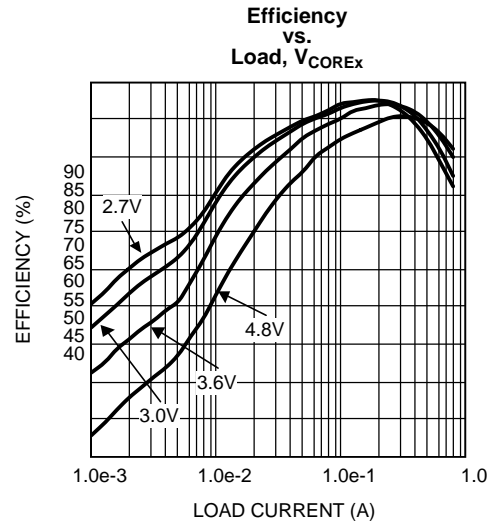

Figure 2.

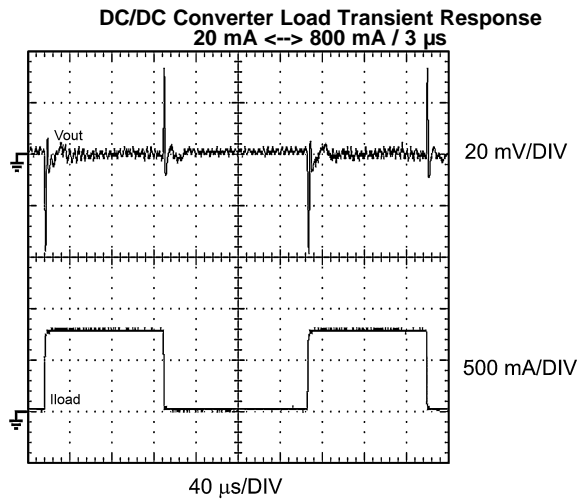

Figure 3.

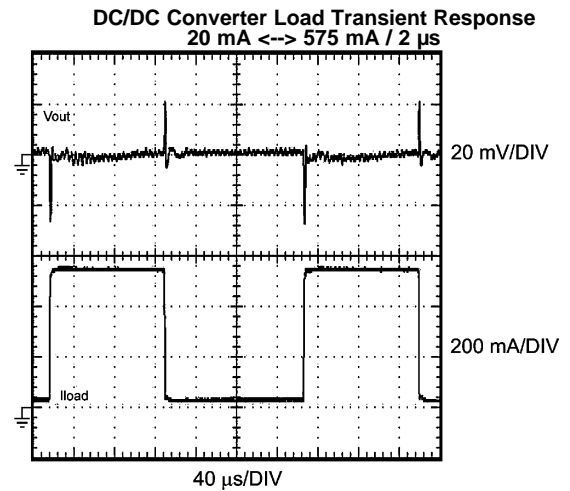

Figure 4.

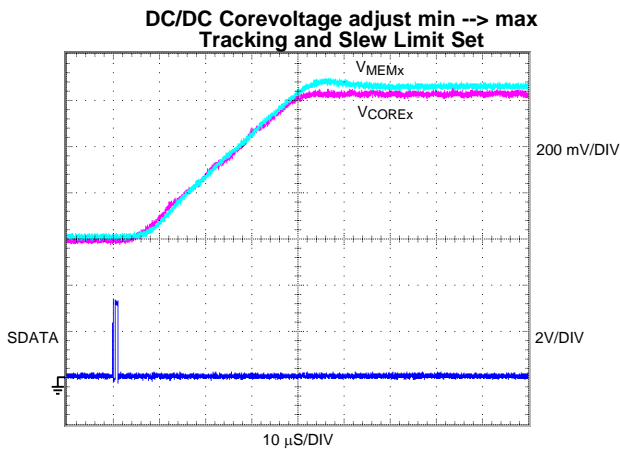

Figure 5.

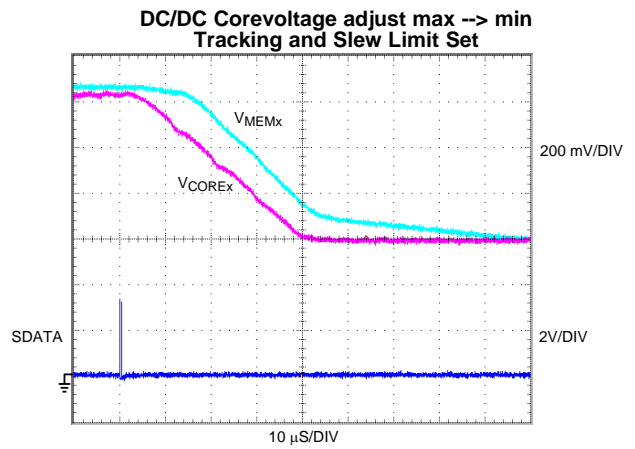

Figure 6.

LP5553 - Typical Performance Characteristics (continued)

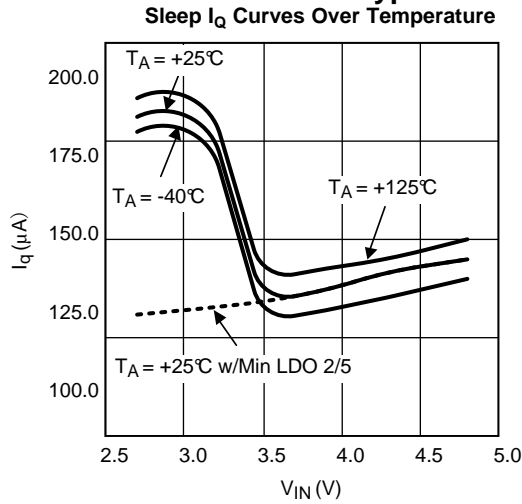

Figure 7.

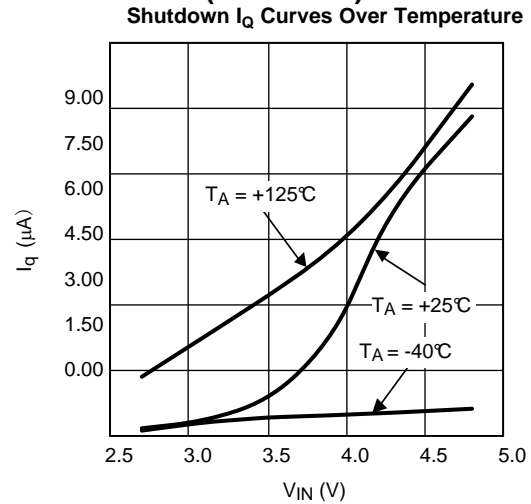

Figure 8.

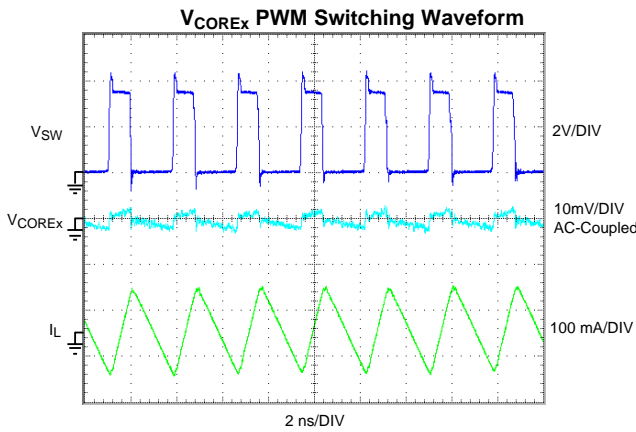

Figure 9.

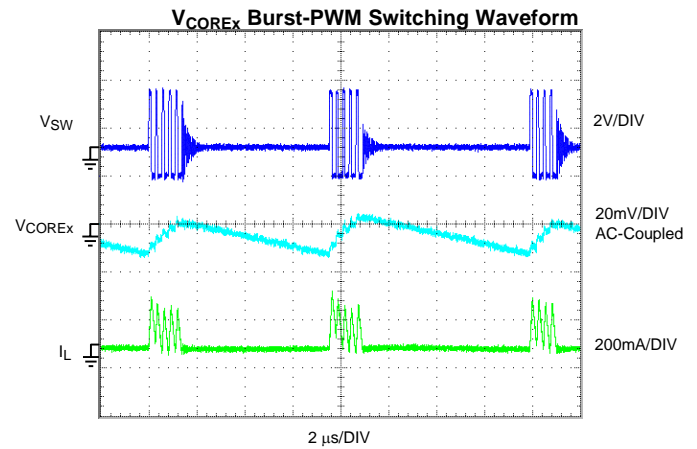

Figure 10.

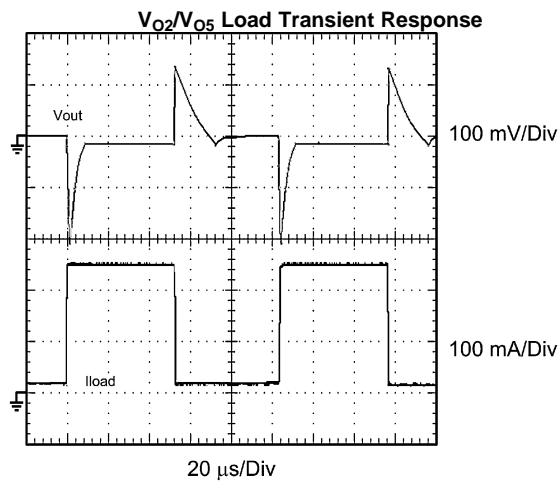

Figure 11.

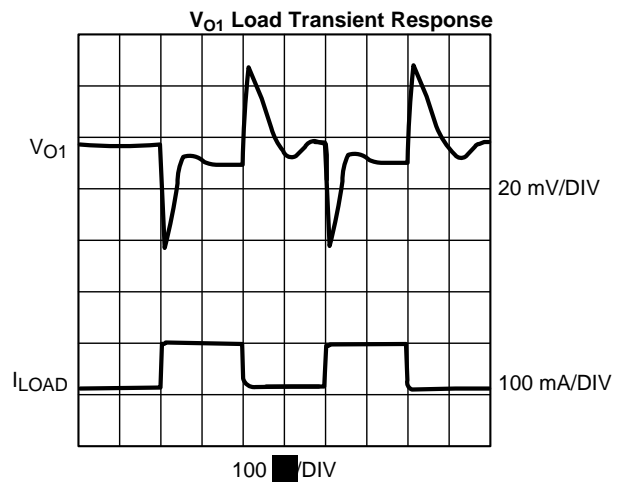

Figure 12.

LP5553 - Typical Performance Characteristics (continued)

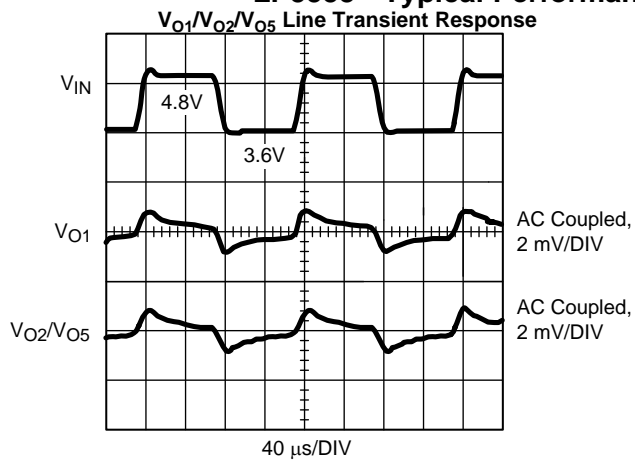

Figure 13.

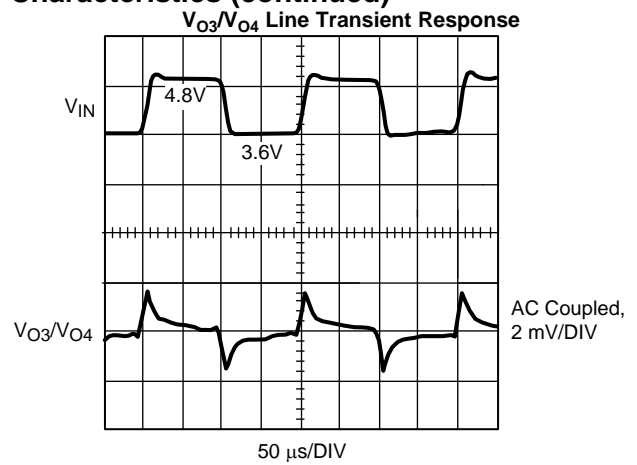

Figure 14.

LP5553 SPMI REGISTER MAP

This table summarizes LP5553 SPMI register usage and shows default register bit values after reset, as programmed by the factory. The following sub-sections provide additional details on the use of each individual register.

Slave Address [N]												
Base Registers												
Register Name	Register Usage	Register Address	Type	Reset Default Value ⁽¹⁾								
				7	6	5	4	3	2	1	0	
R0	Core Voltage 1 Switcher #1	0x00	R/W	0*	1	1	1	1	1	1	1	1
R1	Memory Voltage 1 Independent Mode	0x01	R/W	0*	1	1	0	1	0*	0*	0*	0*
R2	LDO3 Memory Retention Voltage 1 Sleep State	0x02	R/W	0*	1	1	0	1	0*	0*	0*	0*
R3	Reserved Do not use	0x03	N/A	-	-	-	-	-	-	-	-	-
R4	Reserved Do not use	0x04	N/A	-	-	-	-	-	-	-	-	-
R5-R6	Not Implemented											
R7	LDO2 Voltage (I/O Voltage)	0x07	R/W	0*	1	1	1	1	0*	0*	0*	0*
R8	LDO1 Voltage	0x08	R/W	0*	0	1	0	1	0*	0*	0*	0*
R9	LDO5 Voltage	0x09	R/W	0*	1	1	1	1	0*	0*	0*	0*
R10	Enable Control 1	0x0A	R/W	0*	1 V _{CORE1} Enable	1 LDO3 Enable	1 LDO2 Enable	1 LDO1 Enable	1 LDO5 Enable	0*	0	0 Force PWM Switcher #1
R11	Not Implemented											
R12	GPO Data Register	0x0C	R/W	0*	0*	0*	0*	0*	0 GP2	0 GP1	0 GP0	0 GP0
R13	Miscellaneous Control 1	0x0D	R/W	0*	0*	0*	0*	1 GPO Open Drain Select	0 SW1 Slew Control	0 LDO3 Tracking Select	0 LDO3 Low IQ Bit	0 LDO3 Low IQ Bit
R14-R30	Not Implemented											
R31	Reserved Do not use	0x1F	N/A	-	-	-	-	-	-	-	-	-
Extended Registers												
ER0-ER255	Not Implemented											
Extended Long Registers												
ELR0-ELR65535	Not Implemented											

(1) Note: A bit with an asterisk (*) denotes a register bit that is always read as a fixed value. Writes to these bits will be ignored. A bit with a hyphen (-) denotes a bit in a reserved register location. Accessing reserved registers should be avoided to prevent undefined behavior of the LP5553. A write into unimplemented register(s) will be ignored. A read of an unimplemented register(s) will produce a "No response frame". Please refer to SPMI specification for further information.

Slave Address [N+1]											
Base Registers											
Register Name	Register Usage	Register Address	Type	Reset Default Value ⁽¹⁾							
				7	6	5	4	3	2	1	0
R0	Core Voltage 2 Switcher #2	0x00	R/W	0*	1	1	1	1	1	1	1
R1	Memory Voltage 2 Independent Mode	0x01	R/W	0*	1	1	0	1	0*	0*	0*
R2	LDO4 Memory Retention Voltage 2 Sleep State	0x02	R/W	0*	1	1	0	1	0*	0*	0*
R3	Reserved Do not use	0x03	N/A	-	-	-	-	-	-	-	-
R4	Reserved Do not use	0x04	N/A	-	-	-	-	-	-	-	-
R5-R9	Not Implemented										
R10	Enable Control 2	0x0A	R/W	0*	1 V _{CORE2} Enable	1 LDO4 Enable	0*	0*	0*	0*	0 Force PWM Switcher #2
R11-R12	Not Implemented										
R13	Miscellaneous Control 2	0x0D	R/W	0*	0*	0*	0*	0*	0 SW2 Slew Control	0 LDO4 Tracking Select	0 LDO4 Low IQ Bit
R14-R31	Not Implemented										
Extended Registers											
ER0-ER255	Not Implemented										
Extended Long Registers											
ELR0-ELR65535	Not Implemented										

(1) Note: A bit with an asterisk (*) denotes a register bit that is always read as a fixed value. Writes to these bits will be ignored. A bit with a hyphen (-) denotes a bit in a reserved register location. Accessing reserved registers should be avoided to prevent undefined behavior of the LP5553. A write into unimplemented register(s) will be ignored. A read of an unimplemented register(s) will produce a "No response frame". Please refer to SPMI specification for further information.

**Slave Address [N] - 1st Slave Device
R0 - V_{CORE1} - Core Voltage 1**

Address	0x00
Slave Address	N
Type	R/W
Reset Default	8h'7F

Register Bits ⁽¹⁾								Register Value [hex]	Voltage Value [V]
7	6	5	4	3	2	1	0		
Sign	Voltage Data								
0*	0	0	0	0	0	0	0	0x00	0.600
	0	0	0	0	0	0	1	0x01	0.605
	0	0	0	0	0	1	0	0x02	0.610
	0	0	0	0	0	1	1	0x03	0.615
	x	x	x	x	x	x	x	Linear Scaling	
	1	1	1	1	1	1	0	0x7E	1.230
	1	1	1	1	1	1	1	0x7F	1.235 (default)

(1) Note: A bit with an asterisk (*) denotes a register bit that is always read as a fixed value. Write to this bit will be ignored.

R1 - V_{O3} - LDO3 Memory Voltage 1 - Independent Mode

Address	0x01
Slave Address	N
Type	R/W
Reset Default	8h'68

Register Bits ⁽¹⁾								Register Value [hex]	Voltage Value [V]
7	6	5	4	3	2	1	0		
Sign	Voltage Data				Unused				
0*	0	0	0	0	0*	0*	0*	0x00	0.60
	0	0	0	1				0x08	0.65
	0	0	1	0				0x10	0.70
	0	0	1	1				0x18	0.75
	0	1	0	0				0x20	0.80
	0	1	0	1				0x28	0.85
	0	1	1	0				0x30	0.90
	0	1	1	1				0x38	0.95
	1	0	0	0				0x40	1.00
	1	0	0	1				0x48	1.05
	1	0	1	0				0x50	1.10
	1	0	1	1				0x58	1.15
	1	1	0	0				0x60	1.20
	1	1	0	1				0x68	1.25 (default)
	1	1	1	0				0x70	1.30
1	1	1	1	0x78	1.35				

(1) Note: A bit with an asterisk (*) denotes a register bit that is always read as a fixed value. Writes to these bits will be ignored.

R2 - V_{O3} - LDO3 Memory Retention Voltage 1 - Sleep State Value

Address	0x02
Slave Address	N
Type	R/W
Reset Default	8h'68

Register Bits ⁽¹⁾								Register Value [hex]	Voltage Value [V]
7	6	5	4	3	2	1	0		
Sign	Voltage Data				Unused				
0*	0	0	0	0	0*	0*	0*	0x00	0.60
	0	0	0	1				0x08	0.65
	0	0	1	0				0x10	0.70
	0	0	1	1				0x18	0.75
	0	1	0	0				0x20	0.80
	0	1	0	1				0x28	0.85
	0	1	1	0				0x30	0.90
	0	1	1	1				0x38	0.95
	1	0	0	0				0x40	1.00
	1	0	0	1				0x48	1.05
	1	0	1	0				0x50	1.10
	1	0	1	1				0x58	1.15
	1	1	0	0				0x60	1.20
	1	1	0	1				0x68	1.25 (default)
	1	1	1	0				0x70	1.30
	1	1	1	1				0x78	1.35

(1) Note: A bit with an asterisk (*) denotes a register bit that is always read as a fixed value. Writes to these bits will be ignored.

R3 - Reserved

Address	0x03
Slave Address	N
Type	Reserved
Reset Default	8h'00

Register bits							
7	6	5	4	3	2	1	0
Reserved							
Do not use							

R4 - Reserved

Address	0x04
Slave Address	N
Type	Reserved
Reset Default	8h'00

Register bits							
7	6	5	4	3	2	1	0
Reserved							
Do not use							

R7 - V_{O2} - LDO2 Voltage

Address	0x07
Slave Address	N
Type	R/W
Reset Default	8h'78

Register Bits ⁽¹⁾							Register Value [hex]	Voltage Value [V]	
7	6	5	4	3	2	1			0
Sign	Voltage Data				Unused				
0*	0	0	0	0	0*	0*	0*	0x00	1.5
	0	0	0	1				0x08	1.5
	0	0	1	0				0x10	1.5
	0	0	1	1				0x18	1.5
	0	1	0	0				0x20	1.6
	0	1	0	1				0x28	1.7
	0	1	1	0				0x30	1.8
	0	1	1	1				0x38	1.9
	1	0	0	0				0x40	2.0
	1	0	0	1				0x48	2.1
	1	0	1	0				0x50	2.2
	1	0	1	1				0x58	2.3
	1	1	0	0				0x60	2.5
	1	1	0	1				0x68	2.8
1	1	1	0	0x70	3.0				
1	1	1	1	0x78	3.3 (default)				

(1) Note: A bit with an asterisk (*) denotes a register bit that is always read as a fixed value. Writes to these bits will be ignored.

R8 - V_{O1} - LDO1 Voltage

Address	0x08
Slave Address	N
Type	R/W
Reset Default	8h'28

Register Bits ⁽¹⁾								Register Value [hex]	Voltage Value [V]
7	6	5	4	3	2	1	0		
Sign	Voltage Data				Unused				
0*	0	0	0	0	0*	0*	0*	0x00	0.7
	0	0	0	1				0x08	0.8
	0	0	1	0				0x10	0.9
	0	0	1	1				0x18	1.0
	0	1	0	0				0x20	1.1
	0	1	0	1				0x28	1.2 (default)
	0	1	1	0				0x30	1.3
	0	1	1	1				0x38	1.4
	1	0	0	0				0x40	1.5
	1	0	0	1				0x48	1.6
	1	0	1	0				0x50	1.7
	1	0	1	1				0x58	1.8
	1	1	0	0				0x60	1.9
	1	1	0	1				0x68	2.0
	1	1	1	0				0x70	2.1
	1	1	1	1				0x78	2.2

(1) Note: A bit with an asterisk (*) denotes a register bit that is always read as a fixed value. Writes to these bits will be ignored.

R9 - V_{O5} - LDO5 Voltage

Address	0x09
Slave Address	N
Type	R/W
Reset Default	8h78

Register Bits ⁽¹⁾								Register Value [hex]	Voltage Value [V]
7	6	5	4	3	2	1	0		
Sign	Voltage Data				Unused				
0*	0	0	0	0	0*	0*	0*	0x00	1.2
	0	0	0	1				0x08	1.3
	0	0	1	0				0x10	1.4
	0	0	1	1				0x18	1.5
	0	1	0	0				0x20	1.6
	0	1	0	1				0x28	1.7
	0	1	1	0				0x30	1.8
	0	1	1	1				0x38	1.9
	1	0	0	0				0x40	2.0
	1	0	0	1				0x48	2.1
	1	0	1	0				0x50	2.2
	1	0	1	1				0x58	2.3
	1	1	0	0				0x60	2.5
	1	1	0	1				0x68	2.8
	1	1	1	0				0x70	3.0
	1	1	1	1				0x78	3.3 (default)

(1) Note: A bit with an asterisk (*) denotes a register bit that is always read as a fixed value. Writes to these bits will be ignored.

R10 - Enable Control Register 1

Address	0x0A
Slave Address	N
Type	R/W
Reset Default	8h'7C

Register bits ⁽¹⁾							
7	6	5	4	3	2	1	0
Unused	R0, Core Voltage 1 Enable	R2, LDO3 Voltage Enable	R7, LDO2 Voltage Enable	R8, LDO1 Voltage Enable	R9, LDO5 Voltage Enable	Unused	Forced PWM Mode - DC/DC #1
0*	1: regulator is enabled (default) 0: regulator is disabled	1: regulator is enabled (default) 0: regulator is disabled	1: regulator is enabled (default) 0: regulator is disabled	1: regulator is enabled (default) 0: regulator is disabled	1: regulator is enabled (default) 0: regulator is disabled	0*	0: Intelligent and Automatic PFM/PWM Transition - Most Energy Efficient (default) 1: Forced PWM - No PFM Mode Allowed - Smallest Voltage Ripple

(1) Note: A bit with an asterisk (*) denotes a register bit that is always read as a fixed value. Writes to these bits will be ignored.

R12 - GPO Data Register

Address	0x0C
Slave Address	N
Type	R/W
Reset Default	8h'00

Register Bits ⁽¹⁾							
7	6	5	4	3	2	1	0
Unused					GPO2	GPO1	GPO0
0*	0*	0*	0*	0*	General Purpose Output - digital This bit drives the GP2 pin 0: GP2 is low (default) 1: GP2 is high	General Purpose Output - digital This bit drives the GP1 pin 0: GP1 is low (default) 1: GP1 is high	General Purpose Output - digital This bit drives the GP0 pin 0: GP0 is low (default) 1: GP0 is high

(1) Note: A bit with an asterisk (*) denotes a register bit that is always read as a fixed value. Writes to these bits will be ignored.

R13 - Misc Control Register 1

Address	0x0D
Slave Address	N
Type	R/W
Reset Default	8h'08

Register Bits ⁽¹⁾							
7	6	5	4	3	2	1	0
Unused				GPO Open Drain Select	SW1 Slew Control	LDO3 Tracking Select	LDO3 Low I _q Bit
0*	0*	0*	0*	0: GPOs will behave as push-pull CMOS outputs referenced to V _{O2} 1: GPOs will act as open-drain outputs (default)	0: No slew rate restriction on V _{CORE1} DC/DC output voltage (default) 1: Slew rate of V _{CORE1} DC/DC output voltage is reduced	0: LDO3 at R1 register value in Active mode. LDO3 does not track V _{CORE1} (default) 1: LDO3 tracks V _{CORE1} with offset	0: Selects the higher bias point for LDO3 which results in 50 mA operation (default) 1: Selects the lower bias point for LDO3 which results in 5 mA operation See Table 3 for a more detailed explanation of this bit

(1) Note: A bit with an asterisk (*) denotes a register bit that is always read as a fixed value. Writes to these bits will be ignored.

R31 - Reserved

Address	0x1F
Slave Address	N
Type	Reserved
Reset Default	8h'00

Register bits							
7	6	5	4	3	2	1	0
Reserved							
Do not use							

**Slave Address [N+1] - 2nd Slave Device
R0 - V_{CORE2} - Core Voltage 2**

Address	0x00
Slave Address	N + 1
Type	R/W
Reset Default	8h'7F

Register Bits ⁽¹⁾								Register Value [hex]	Voltage Value [V]
7	6	5	4	3	2	1	0		
Sign	Voltage Data								
0*	0	0	0	0	0	0	0	0x00	0.600
	0	0	0	0	0	0	1	0x01	0.605
	0	0	0	0	0	1	0	0x02	0.610
	0	0	0	0	0	1	1	0x03	0.615
	x	x	x	x	x	x	x	Linear Scaling	
	1	1	1	1	1	1	0	0x7E	1.230
	1	1	1	1	1	1	1	0x7F	1.235 (default)

(1) Note: A bit with an asterisk (*) denotes a register bit that is always read as a fixed value. Write to this bit will be ignored.

R1 - V_{O4} - LDO4 Memory Voltage 2 - Independent Mode

Address	0x01
Slave Address	N + 1
Type	R/W
Reset Default	8h'68

Register Bits ⁽¹⁾								Register Value [hex]	Voltage Value [V]
7	6	5	4	3	2	1	0		
Sign	Voltage Data				Unused				
0*	0	0	0	0	0*	0*	0*	0x00	0.60
	0	0	0	1				0x08	0.65
	0	0	1	0				0x10	0.70
	0	0	1	1				0x18	0.75
	0	1	0	0				0x20	0.80
	0	1	0	1				0x28	0.85
	0	1	1	0				0x30	0.90
	0	1	1	1				0x38	0.95
	1	0	0	0				0x40	1.00
	1	0	0	1				0x48	1.05
	1	0	1	0				0x50	1.10
	1	0	1	1				0x58	1.15
	1	1	0	0				0x60	1.20
	1	1	0	1				0x68	1.25 (default)
	1	1	1	0				0x70	1.30
	1	1	1	1				0x78	1.35

(1) Note: A bit with an asterisk (*) denotes a register bit that is always read as a fixed value. Writes to these bits will be ignored.

R2 - V_{O4} - LDO4 Memory Retention Voltage 2 - Sleep State Value

Address	0x02
Slave Address	N + 1
Type	R/W
Reset Default	8h'68

Register Bits ⁽¹⁾								Register Value [hex]	Voltage Value [V]
7	6	5	4	3	2	1	0		
Sign	Voltage Data				Unused				

(1) Note: A bit with an asterisk (*) denotes a register bit that is always read as a fixed value. Writes to these bits will be ignored.

0*	0	0	0	0	0*	0*	0*	0x00	0.60
	0	0	0	1				0x08	0.65
	0	0	1	0				0x10	0.70
	0	0	1	1				0x18	0.75
	0	1	0	0				0x20	0.80
	0	1	0	1				0x28	0.85
	0	1	1	0				0x30	0.90
	0	1	1	1				0x38	0.95
	1	0	0	0				0x40	1.00
	1	0	0	1				0x48	1.05
	1	0	1	0				0x50	1.10
	1	0	1	1				0x58	1.15
	1	1	0	0				0x60	1.20
	1	1	0	1				0x68	1.25 (default)
	1	1	1	0				0x70	1.30
	1	1	1	1				0x78	1.35

R3 - Reserved

Address	0x03
Slave Address	N + 1
Type	Reserved
Reset Default	8h'00

Register bits							
7	6	5	4	3	2	1	0
Reserved							
Do not use							

R4 - Reserved

Address	0x03
Slave Address	N + 1
Type	Reserved
Reset Default	8h'00

Register bits							
7	6	5	4	3	2	1	0
Reserved							
Do not use							

R10 - Enable Control Register 2

Address	0x0A
Slave Address	N + 1
Type	R/W
Reset Default	8h'60

Register bits ⁽¹⁾								
7	6	5	4	3	2	1	0	
Unused	R0, Core Voltage 2 Enable	R2, LDO4 Voltage Enable	Unused				Forced PWM Mode - DC/DC #2	
0*	1: regulator is enabled (default) 0: regulator is disabled	1: regulator is enabled (default) 0: regulator is disabled	0*	0*	0*	0*	0: Intelligent and Automatic PFM/PWM Transition - Most Energy Efficient (default) 1: Forced PWM - No PFM Mode Allowed - Smallest Voltage Ripple	

(1) Note: A bit with an asterisk (*) denotes a register bit that is always read as a fixed value. Writes to these bits will be ignored.

R13 - Misc Control Register 2

Address	0x0D
Slave Address	N + 1
Type	R/W
Reset Default	8h'00

Register Bits ⁽¹⁾							
7	6	5	4	3	2	1	0
Unused				SW2 Slew Control		LDO4 Tracking Select	LDO4 Low I _Q Bit
0*	0*	0*	0*	0*	0: No slew rate restriction on V _{CORE2} DC/DC output voltage (default) 1: Slew rate of V _{CORE2} DC/DC output voltage is reduced	0: LDO4 at R1 register value in Active mode. LDO3 does not track V _{CORE2} (default) 1: LDO4 tracks V _{CORE2} with offset	0: Selects the higher bias point for LDO4 which results in 50 mA operation (default) 1: Selects the lower bias point for LDO4 which results in 5 mA operation See Table 3 for a more detailed explanation of this bit

(1) Note: A bit with an asterisk (*) denotes a register bit that is always read as a fixed value. Writes to these bits will be ignored.

LP5553 Operation

GENERAL DESCRIPTION

The LP5553 is a System Power Management Interface (SPMI) compliant energy management unit (EMU) for application or baseband processors in mobile phones and other portable equipment. It operates cooperatively with processors using Advanced Power Controller (APC) to provide Adaptive Voltage Scaling (AVS) which drastically improves processor efficiencies compared to conventional power delivery methods. The LP5553 consists of two high efficiency switching DC/DC buck converters to supply two voltage scaling domains and five LDOs for supplying additional support circuitry.

VOLTAGE SCALING

The LP5553 is designed to be used in a voltage scaling system to lower the power dissipation of the system. By scaling supply voltage with the clock frequency of a processor, dramatic power savings can be achieved. Two types of voltage scaling are supported, dynamic voltage scaling (DVS) and adaptive voltage scaling (AVS). Both DC/DC 1 and 2 support AVS and DVS modes. DVS systems switch between pre-characterized voltages, which are paired to clock frequencies used for frequency scaling in the processor. AVS systems track the processor performance and optimize the supply voltage to the required performance. AVS is a closed loop system that provides process and temperature compensation such that for any given processor, temperature, or clock frequency, the minimum supply voltage is delivered.

SYSTEM POWER MANAGEMENT INTERFACE

LP5553 is compliant with the SPMI specification low-speed device category and operates at bus speeds below 15 MHz. SPMI interface controls the various voltages, modes and states of the regulators in the LP5553. SPMI control of DC/DC 1 and 2 facilitates PowerWise AVS and DVS operation.

LP5553 implements two non-request capable logic slaves in addresses N and N+1. N is selectable with SA[3:0] pins. Both slaves in the LP5553 support the following SPMI commands as described in the SPMI specification:

- Reset
- Sleep
- Shutdown
- Wakeup
- Register Read
- Register Write
- Register 0 Write
- Authenticate

Please see the SPMI specification for a complete description of the interface standard.

The 2-wire SPMI interface is composed of the SCLK and SDATA pins on the LP5553. SCLK is always an input to the LP5553 and should be driven by a SPMI master in the system. The SCLK clock rate can operate from 32 kHz to 15 MHz. SDATA is a bi-directional serial data line. It can drive a 50pF line and meet timing standards for a 15 MHz SPMI bus. Both signals are referenced to the voltage present at VO2, the LDO2 output voltage. Both signals contain an internal pull-down resistor of ~1 MΩ, in accordance with the SPMI specification.

Unsupported Features

LP5553 does not support optional SPMI commands: Extended Register Read and Write, Extended Register Read Long, Extended Register Write Long and MIPI Descriptor Block (DDB) Slave Read. LP5553 does not support any master specific commands.

SPMI slaves are divided into Request Capable Slaves and Non-Request Capable Slaves. Request Capable Slaves have capability to initiate and send sequences to any other Master or Slave connected to the SPMI bus. LP5553 is Non-Request Capable Slave and thus it is not able to initiate sequences. Please refer to the SPMI specification for a complete description of all SPMI functionality.

SLAVE ADDRESSING DESCRIPTION

SPMI supports up to 16 logical slaves in the same system. The LP5553 contains 2 logical slaves. The 3 MSBs of the LP5553's slave address are set by the SA1, SA2 and SA3 pins. They are actively decoded by the LP5553 for every transaction. The LSB of the slave address is hardwired inside the LP5553. Slave 'N' will always be located at SA[0] = 0 and slave 'N+1' will always exist at SA[0] = 1. As an example, if we were to tie SA1 = SA3 = VDD and SA2 = GND in our system, then the LP5553's slave 'N' would be located at SA[3:0] = 0xA and slave 'N+1' would be SA[3:0] = 0xB.

CONTROL AND STATUS SIGNALS

The LP5553 implements all 3 of the SPMI control and status signals. ENABLE and RESETN are inputs to the LP5553 that allow for power-up and power-down sequencing, as well as resetting the EMU to a known state. Both ENABLE and RESETN must be a logic '1' during normal operation. PWROK is an indicator to the system that the LP5553 is in regulation and power is stable. It's output is dependent upon the state of the two slave devices. Value of PWROK signal is logic '1' if at least one of the slaves is in active or sleep state. See [Table 1](#), "PWROK Value Per Slave State," below for details. All 3 signals are asynchronous signals.

Table 1. PWROK Value Per Slave State

		SLAVE (N+1)			
		STARTUP	ACTIVE	SLEEP	SHUTDOWN
SLAVE (N)	STARTUP	0	1	1	0
	ACTIVE	1	1	1	1
	SLEEP	1	1	1	1
	SHUTDOWN	0	1	1	0

GENERAL PURPOSE OUTPUTS

The LP5553 contains 3 digital output pins that can be used as the system designer sees fit. By default, they are configured as open-drain outputs, outputting a logic '0'. They can be changed to a push-pull CMOS output by clearing Slave 'N', R13[3]. In the open-drain configuration, they can be referenced to any voltage less than the VDD of the LP5553. The push-pull output mode will reference the high-side to the voltage of LDO2. The 3 GPO pins are ensured to sink and source 1mA of current.

SLAVE OPERATING STATES

Each slave in the LP5553 has four operating states: Startup, Active, Sleep and Shutdown. (Figure 15)

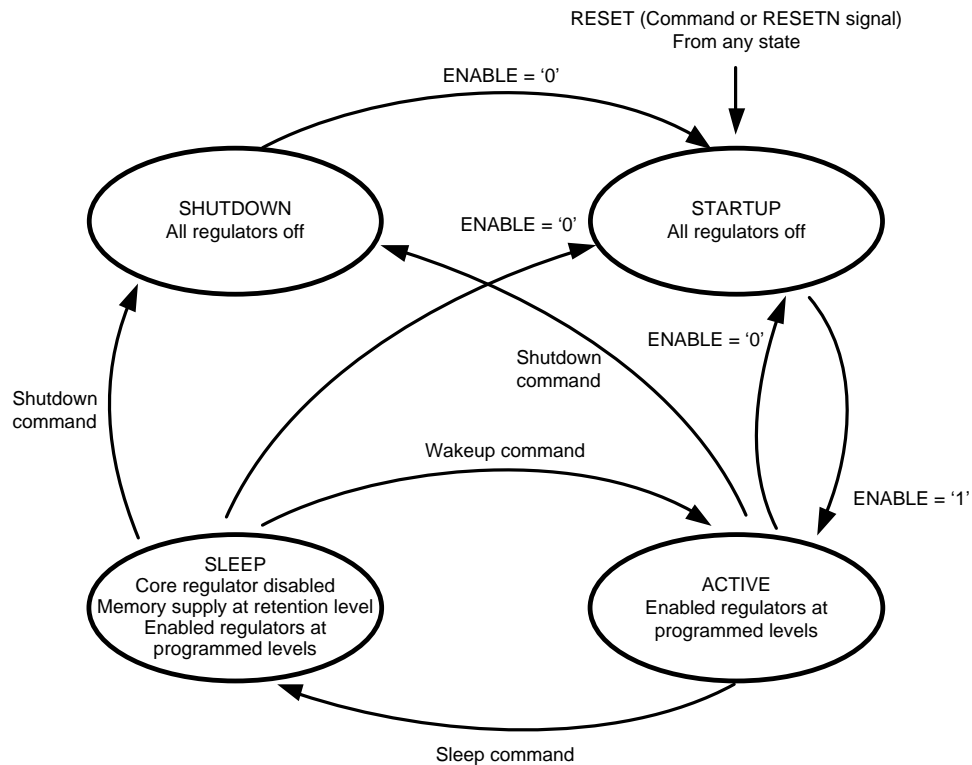

Figure 15. LP5553 Slave State Diagram

The Startup state is the default state for both slaves after reset. All regulators are off and PWROK output is a '0'.

The device will move to the Active state when the external ENABLE and RESETN signals are both pulled high. After the state transition completes, both slaves will be in the Active state, but each slave will maintain its own independent state thereafter.

The default, factory-programmed power-up sequence of the LP5553 can be seen in Figure 16. From the global ENABLE of the chip, there is ~80 μ s of time for powering on and stabilizing internal support circuitry. Once this time has expired, the start-up time slots begin. Table 2 shows the time slots that each regulator begins in. Note that for the switchers, there is an additional ~75 μ s of set-up time from the beginning of the time slot until the soft-start ramp begins.

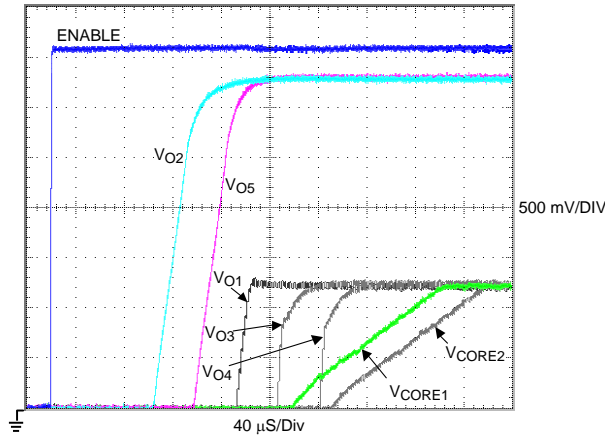

Figure 16. LP5553 Startup Timing

Table 2. Factory Programmed Startup Time Slots

Time slot	Start time (μ s)	Regulator(s)
0	0	LDO2
1	32	LDO5/AVS1
2	64	LDO1/AVS2
3	96	LDO3
4	128	LDO4

In the Active state, all regulators that are enabled are on and their outputs are defined by their programmed register values. If the Active state has been reached from the Startup state, the regulators will be programmed to their default value. In the Active state, the SPMI master has complete control over the LP5553’s operation. The PWROK output is ‘1’ if either slave is in this state.

The Sleep state is entered by issuing the Sleep command on the SPMI bus. The core regulator of the addressed slave and the associated memory LDO will both respond to the Sleep command. For the first 32 μ s after the command is decoded, the core regulator will transition to its zero-code value of 0.6V and the LDO will move to its POR value of 1.25V. After the 32 μ s has expired, the core regulator will be turned off and the LDO will transition to its memory retention value as programmed in register R2. See Figure 17. LDO1, LDO2 and LDO5 are unaffected by the Sleep command and will maintain their programmed values. They may be turned off manually, if desired. The LP5553 will still respond to all SPMI traffic as long as LDO2 remains active.

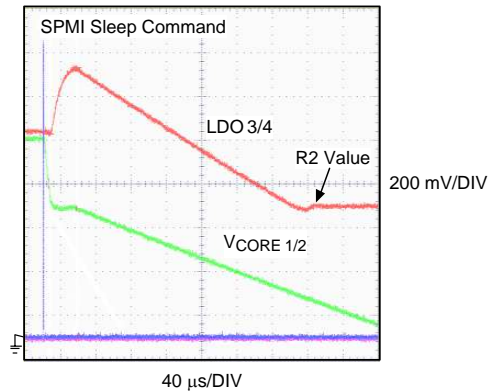

Figure 17. Sleep Behavior of Core and Memory

A slave may return to the Active state by issuing the Wakeup command. This will result in the core regulator turning on after a $\sim 75 \mu\text{s}$ delay and a soft-start ramp. It will wake up at its maximum value of 1.235V. The associated memory LDO will go to its default POR value of 1.25V until the core has reached the end of its soft-start period and then will transition to its programmed configuration (i.e., either tracking the core or to the value programmed in R1). See [Figure 18](#). The PWROK output is '1' if either slave is in this state.

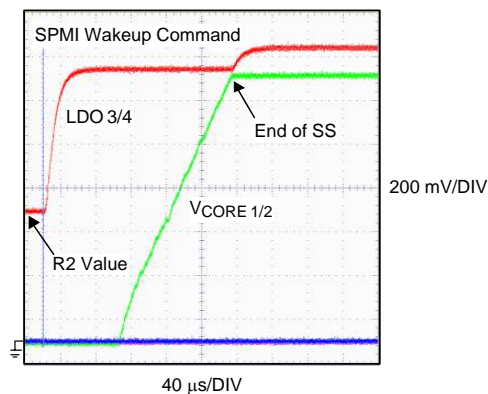

Figure 18. Wakeup Behavior of Core and Memory

The Shutdown command will place the addressed slave in the Shutdown state. This command may be issued to any slave in either the Active or Sleep states. All regulators within that state will turn off. The LP5553 holds out one exception to this rule. LDO1, LDO2 and LDO5 act as a shared resource between the two slave devices in the EMU. Therefore, placing just slave 'N' into Shutdown will not turn off these regulators even though their registers exist within that space. Slave 'N' can be in the Shutdown state, but as long as Slave 'N+1' is still in either Active or Sleep states, these shared LDOs will remain on and SPMI traffic will be decoded. When only one of the slaves is in the Shutdown state, it can be started up by sending the Reset command to that slave. Once the Shutdown command has been sent to both slaves, all regulators on the LP5553 will be turned off. The PWROK signal will be '0' if both slaves are in the Shutdown state. The only way to transition away from the Shutdown state is by disabling or resetting the LP5553. By taking the ENABLE pin or the RESETN pin low, the LP5553 will transition to the Startup state.

Power-down sequencing is not actively managed by the LP5553 logic, but can be handled by turning off regulators in the desired order within the application, prior to Shutdown.

PWM/BURST-PWM OPERATION

The switching regulators in the LP5553 have two modes of operation, pulse width modulation (PWM) and “Burst”-PWM. In PWM, the converter switches at 3.6 MHz. Each period can be split into two cycles. During the first cycle, the high-side switch is on and the low-side switch is off. During this cycle, the inductor current is rising. In the second cycle, the high-side switch is off and the low-side switch is on causing the inductor current to decrease. The output ripple voltage is lowest in PWM mode. As the load current decreases, the converter efficiency becomes worse due to switching losses. The LP5553 will automatically transition to Burst mode at light load current levels. The exact transition point is dependent upon the present operating environment and the mode assessment is constantly evaluated. The transition is approximately equal to:

$$I_{\text{PWM/Burst-PWM}} \approx \frac{V_{\text{OUT}}}{V_{\text{IN}}} \times \frac{V_{\text{IN}} - V_{\text{OUT}}}{2 \times L \times f_{\text{S}}}$$

In this mode, the output voltage will be allowed to coast with no switching action by the regulator. When the output voltage dips to 1% below nominal, the switches are enabled, the voltage is boosted back up to the programmed value and the coast process repeats itself. If the user desires tighter control of the output voltage, at the expense of light-load efficiency, the switchers can be commanded to stay in PWM-only mode by setting bit 0 of R10 in the slave’s registers.

CURRENT LIMITING

A current limit feature exists for all regulators to help protect the LP5553 and external components during overload conditions. The switcher’s current limit feature will trip around 1.2A (typ). Once the fault has occurred and current limit has been entered, the switcher will not resume operation until the output current has decreased to a hysteretic low-level set point. Normal operation will proceed after the fault has been cleared. Likewise, the LDOs all implement current limit and will turn off their pass element when their trip point is reached. Please refer to the [Electrical Characteristics](#) section for details.

SOFT START

Both switching regulators implement a digital soft-start feature to limit in-rush current during the Startup to Active state transition. The voltage output of the switchers will be gradually increased to the default value of 1.235V. An unloaded switcher output will reach its final value in 120 μs (typ.) while a fully loaded switcher – 800 mA -- will reach its output in 135 μs (typ). Because the LP5553 uses voltage increments to handle soft-start, its turn-on time is less dependent on output capacitance and load current than regulators that gradually increase current limit to implement soft-start.

LDO2

The on-board LDO2 regulator has special significance to the LP5553. All digital data on the SCLK, SDATA and the GPOx pins while in push-pull mode, is referenced to this voltage. This regulator is used internally to power the I/O drivers. As such, this regulator must be on in order to communicate with the LP5553. The user should ensure that this regulator does not go into dropout or SPMI communication will most likely not be possible. If it is not desirable to use this regulator in the system, the user can turn this regulator off by setting bit 4 of R10 in Slave ‘N’ during system initialization while back-driving the required I/O voltage onto the pin.

TRACKING, SLEW RATE LIMITING AND LOW I_Q BITS

There are 3 bits in each slave’s R13 register that determine the performance and operational behavior of the V_{COREX} and V_{O3}/V_{O4} outputs. Their significance and interaction is described below.

The Low I_Q bit setting in R13, bit 0, of each slave allows the selection of a lower I_Q bias point at the expense of decreased output current capability for V_{O3} and V_{O4}. At reset, the default setting is high I_Q mode (i.e., bit 0 is cleared) which results in a 50 mA output capability for the associated LDO. If bit 0 is set, the quiescent current draw of the part will decrease, but the output current capability of the associated LDO will drop to 5 mA. Setting V_{O3} and V_{O4} up for low I_Q mode is useful in situations where just a trickle of current is required, such as when maintaining some type of low-power memory.

The Tracking bit, bit 1 in R13, determines whether or not the LDO3 voltage will track the V_{CORE1} voltage in Slave 'N'. Slave 'N+1' has its own tracking bit which will determine whether LDO4 tracks V_{CORE2} . Each slave device can be independently configured to tracking or independent mode. When set to operate independently, LDO3 and LDO4 will maintain a voltage output equal to the programmed value of R1 while in the Active state. When set to operate in tracking mode, LDO3 and LDO4 will track the output voltage of their associated switcher, attempting to maintain approximately a 25 mV positive offset.

There is some interaction between the Low I_Q and Tracking bits based on the state of the slave device and that is detailed in the following table:

Table 3. Tracking, IQ Bit, Slave State Truth Table

Input			Output
Tracking, R13[1]	Low I_Q , R13[0]	State	LDO3/LDO4 Capability
0	0	Active	50 mA
0	0	Sleep	50 mA
0	1	Active	5 mA
0	1	Sleep	5 mA
1	0	Active	50 mA
1	0	Sleep	50 mA
1	1	Active	50 mA
1	1	Sleep	5 mA

The final bit, the Slew Rate Limiting bit (R13[2]), places a limit on how fast the output voltage of the V_{COREx} regulators can change. If slew rate limiting is not enabled while in tracking mode (i.e., R13[2] is cleared), then the switcher will achieve its new programmed value faster than the tracking LDO can change its output. By setting the Slew Rate Limiting bit, the LP5553 will attempt to keep the positive offset of the tracking LDO in relation to the V_{COREx} output.

For AVS systems, the expected configuration is to have all 3 bits, R13[2:0] set to '1'. It generally will not make sense to set the Slew Rate Limiting bit while not in tracking mode. Setting all 3 bits will result in a system which has the following properties:

1. The tracking LDO will maintain positive offset from V_{COREx} in Active state.
2. Tracking LDO will be 50mA output capable in Active state and 5mA capable in Sleep state.

Application Hints

SWITCHERS

Input Capacitors

The input capacitor to a switching regulator supplies the AC switching current drawn from the switching action of the internal power FETs. The input current of a buck converter is discontinuous, so the ripple current supplied by the input capacitor is large. The input capacitor must be rated to handle this current:

$$I_{\text{RMS_CIN}} = I_{\text{OUT}} \sqrt{\frac{V_{\text{OUT}} \times (V_{\text{IN}} - V_{\text{OUT}})}{V_{\text{IN}}}} \quad (\text{A})$$

The power dissipated in the input capacitor is given by:

$$P_{\text{D_CIN}} = I_{\text{RMS_CIN}}^2 \times R_{\text{ESR_CIN}} \quad (\text{W})$$

The input capacitor must be rated to handle both the RMS current and the dissipated power. A 10 μF ceramic capacitor, rated to handle at least 10V, is recommended for each PVDDx/PGNDx pair.

Inductor

A 1 μH inductor should be used for the switchers' output filter. The inductor should be rated to handle the peak load current plus the ripple current:

$$\begin{aligned}
 I_{L(\text{MAX})} &= I_{\text{LOAD}(\text{MAX})} + \Delta I_{L(\text{MAX})} \\
 &= I_{\text{LOAD}(\text{MAX})} + \frac{D \times (V_{\text{IN}(\text{MAX})} - V_{\text{OUT}})}{2 \times L \times f_s} \\
 &= I_{\text{LOAD}(\text{MAX})} + \frac{D \times (V_{\text{IN}(\text{MAX})} - V_{\text{OUT}})}{9.4} \text{ (A)}, \\
 &\quad \left\{ \begin{array}{l} f_s = 1 \text{ MHz,} \\ L = 4.7 \mu\text{H} \end{array} \right.
 \end{aligned}$$

Table 4. Suggested Inductors and Their Suppliers

Model	Vendor	Dimensions LxWxH (mm)	DCR (Typical)
LPS3010-102	Coilcraft	3.0 x 3.0 x 1.0	85 mΩ
LQM31PN1R0MC0	muRata	3.2 x 1.6 x 0.5	140 mΩ

Output Capacitors

The switchers in the LP5553 are designed to be used with 10 μF of capacitance in the output filter. It is recommended that a 10 μF ceramic capacitor, rated to handle at least 10V and comprised of X5R dielectric material, be chosen. The output capacitor of a switching regulator absorbs the AC ripple current from the inductor and provides the initial response to a load transient. The ripple voltage at the output of the converters is the product of the ripple current flowing through the output capacitor and the impedance of the capacitor. The impedance of the capacitor can be dominated by capacitive, resistive, or inductive elements within the capacitor or the PCB interconnect, depending upon the frequency of the ripple current. Ceramic capacitors are predominantly used in portable systems and have very low ESR and should remain capacitive given good PCB layout practices. The switcher peak-to-peak output voltage ripple in steady state can be calculated as:

$$V_{PP} = I_{LPP} \left(R_{ESR} + \frac{1}{f_s \times 8 \times C_{OUT}} \right)$$

Table 5. Suggested Switcher Output Capacitors and Their Suppliers

Model	Vendor	Value	Type	Voltage	Case Size (Height)
GRM219R61A106KE44	muRata	10 μF	Ceramic, X5R	10V	0805 (0.85 mm)
LMK212BJ106KD	Taiyo Yuden	10 μF	Ceramic, X5R	10V	0805 (0.85 mm)

A NOTE ABOUT CAPACITORS

Capacitors are typically specified by their manufacturers as a particular value +/-X%. These specified values are only valid for a particular test condition that is often not applicable to the final application circuit. If you were to take a ceramic 10 μF capacitor in 0805 package and measure it with an LCR meter, a typical result would be around 7 μF. This is before you even insert the capacitor into the application circuit. Capacitance will decrease with increasing frequency and DC bias point and will generally vary with temperature. A typical 6.3V, 10 μF, 0603 capacitor may only be providing 4 - 5 μF of capacitance when used as the output capacitor in the switching regulators' loop filter. It is highly recommended that measurements be done on your selected capacitor(s) to ensure you have the proper amount of capacitance.

LDOs**Input Capacitors**

While not mandatory, it is highly recommended that some input capacitance be provided for the DVDDx and AVDDx pins. Typical values may be in the 0.1 - 1.0 μF range. These capacitors will provide bypass for the LP5553 control electronics and LDOs.

Output Capacitors

The output capacitor of an LDO sets a low frequency pole and a high frequency zero in the control loop of an LDO, as well as providing the initial response for a load transient. The capacitance and the equivalent series resistance (ESR) of the capacitor must be within a specified range to meet stability requirements. The LDOs in the LP5553 are designed to be used with ceramic output capacitors. The following table can be used to select suitable output capacitors:

Table 6. LDO Output Capacitor Selection Guide

	Output Capacitance Range (Recommended Typical Value)	ESR Range
LDO1	1.0 - 20 μ F (2.2 μ F)	5 m Ω - 500 m Ω
LDO2	2.0 - 20 μ F (4.7 μ F)	5 m Ω - 500 m Ω
LDO3	0.7 - 2.2 μ F (1.0 μ F)	5 m Ω - 500 m Ω
LDO4	0.7 - 2.2 μ F (1.0 μ F)	5 m Ω - 500 m Ω
LDO5	2.0 - 20 μ F (4.7 μ F)	5 m Ω - 500 m Ω

Dropout Voltages

All linear regulators are subject to dropout. Dropout Voltage is the minimum voltage required across the regulator ($V_{IN} - V_{OUT}$) to maintain a constant, specified output voltage. The LP5553 has a V_{IN} range of 2.7V – 4.8V. V_{O1} , V_{O3} and V_{O4} cannot be programmed to a level that would make dropout a factor. However, V_{O2} and V_{O5} can reach as high as 3.3V on their outputs. Both of those regulators have a dropout voltage of 260mV (MAX). To ensure proper operation of those regulators, the user should ensure that $V_{IN} \geq (V_{OX-PROGRAMMED} + 260 \text{ mV})$. If a regulator does go into dropout, the output voltage will start to track the input: $V_O = V_{IN} - V_{DROPOUT}$. Also, the PSRR will go to zero, meaning any noise at the input will be seen at the output.

BOARD LAYOUT CONSIDERATIONS

PC board layout is an important part of DC-DC converter design. Poor board layout can disrupt the performance of a DC-DC converter and surrounding circuitry by contributing to EMI, ground bounce and resistive voltage loss in the traces. These can send erroneous signals to the DC-DC converter IC, resulting in poor regulation or instability. Good layout for the LP5553 can be implemented by following design rules below. See [Figure 19](#) through [Figure 31](#) for a good example of proper layout (LP5553 Evaluation Board). It is also recommended to reference AN-1112 for information on the micro SMD package and its requirements.

The evaluation board is comprised of four layers. From top to bottom they are:

1. Top layer, component side
2. Ground plane
3. V_{IN} plane
4. Bottom layer

Being a very high performance EMU in a small physical package requires that some care be taken when placing the IC into the application circuit. The breakout of the IC should be done as similarly to the example artwork as possible. Everything on the outer ring of the micro SMD should be routed on the component layer while microvias are used to escape the remaining signals on the adjacent layer. The layout should be done in the following order to ensure best performance:

1. Switchers
2. System Power Management Interface (SPMI)
3. Input Caps
4. LDO Output Caps
5. Any remaining layout

For good performance of the circuit, it is essential to place the input and output capacitors as close as physically possible to the associated pin.

Sensitive components should be placed far from those components with high switching currents.

It's a good practice to minimize high-current and switching current paths.

DC/DC Buck Switching Regulators

Due to the high switching currents and accuracy of the LP5553, this is the most crucial aspect of the layout. And because the switchers are almost a complete mirror image of one another on the part, the design is most easily placed symmetrically about the part.

The 10 μ F input capacitors should be placed first, as near to PVDDx and PGNDx as possible. PVDDx (pins A6 and A1) are the voltage rails for the high-side power FETs. PGNDx (pins A4 and A3) are the return paths for the low-side power FETs. As seen with C3 and C4 in the artwork, these components have their associated pads very near the pins that they will decouple. These capacitors are important in sourcing charge during switching events.

The 10 μ F output capacitors are the next components to be placed. They can be seen in the artwork as C1 and C2. Best performance of the LP5553 will be realized by maintaining tight physical coupling of the grounds of the input capacitor, output capacitor and PGND pin for each switcher. By placing the input/output capacitors as depicted, a channel is created that will allow routing the switching node out to the inductor between the pads of the input and output capacitors.

The output magnetics should be placed in a way that best allows the switching node, output node and supplied load to be routed easily. The inductors and associated connections, are the least sensitive to layout variation. Note that the evaluation board contains a 0-ohm series resistor between the switching node and the inductor. This is included as a means to more easily make measurements on the evaluation board and is NOT required in the application circuit.

Once placement of these components has been completed, the associated wiring/routing should be done. The switching nodes should be routed to their associated inductors. Next, a ground polygon and/or plane should be used to tie all capacitor grounds together and to the PGNDs. An example of this is shown in the board artwork. Here we have a pour on the top layer that connects everything together and we stitched it into the ground plane to maintain the same potential at both points. There will be quite a bit of switching current in this area so it should be physically isolated from other sensitive circuitry. Once the ground connections are in place, proceed to routing the V_{IN} connections. Finally, the FBx and RGND contacts should be routed. The RGND should tie into a quiet location that will track the potential of the PGND pins. On the evaluation board layout, this connection was made at the edge of the ground polygon on the top layer. Evaluation board contains a 0-ohm series resistor (R13) on the RGND line. This is not required in the application circuit. The FB lines should closely match the RGND routing to reduce the inductive loop of this pair. The FB and RGND lines make up a highside and low-side sense connection to maintain the accuracy of the switcher outputs. The FB line should cross the switching trace as close to perpendicular as possible and tie into the output node of the regulator. Low impedance power connections should be maintained for all of these connections.

SPMI Routing

The System Power Management Interface SCLK and SDATA lines should then be routed to the appropriate master in the system. If this is a multi-master and/or multi-slave system, care should be taken in matching the trace lengths of all segments of the SPMI bus. Additionally, the designer must ensure that the electrical characteristics of the interconnect do not violate the restrictions in the SPMI specification.

Input Capacitors

Any additional input decoupling capacitors that are part of the design should now be placed and routed. In the case of the evaluation board, this includes capacitors C5 and C6. They are general purpose caps and are tied directly to the V_{IN} plane on the board. It is not mandatory to include additional bypass caps, however it is recommended. Low impedance connections are required to allow the capacitors to function at their peak performance. Regardless of any decoupling capacitors, EVERY V_{IN} CONNECTION SHOULD HAVE ITS OWN ROUTING FROM THE SOURCE. Vias and/or traces should NOT be shared amongst V_{IN} pins. The PVDDx pins especially should have their own separate supply connections.

LDO Output Capacitors

This step involves placing the output capacitors of the LDO regulators. If an LDO will not be used, it is not necessary to place its output capacitor in the design. These capacitors should be placed as physically close to the LP5553 IC as possible. Again, use low-impedance connections to the output capacitors for best performance.

Evaluation Board Schematic

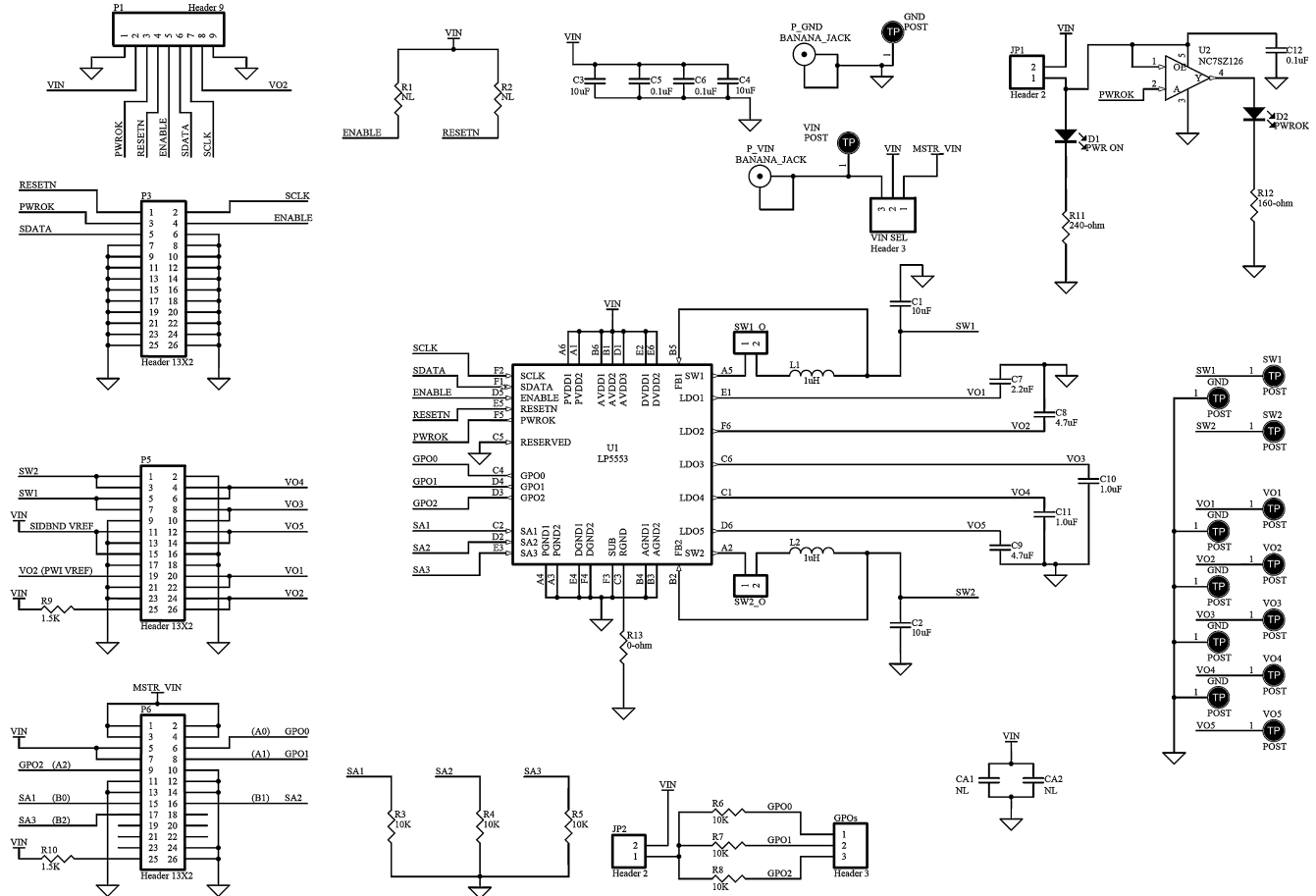

Figure 19. LP5553 Evaluation Board Schematic

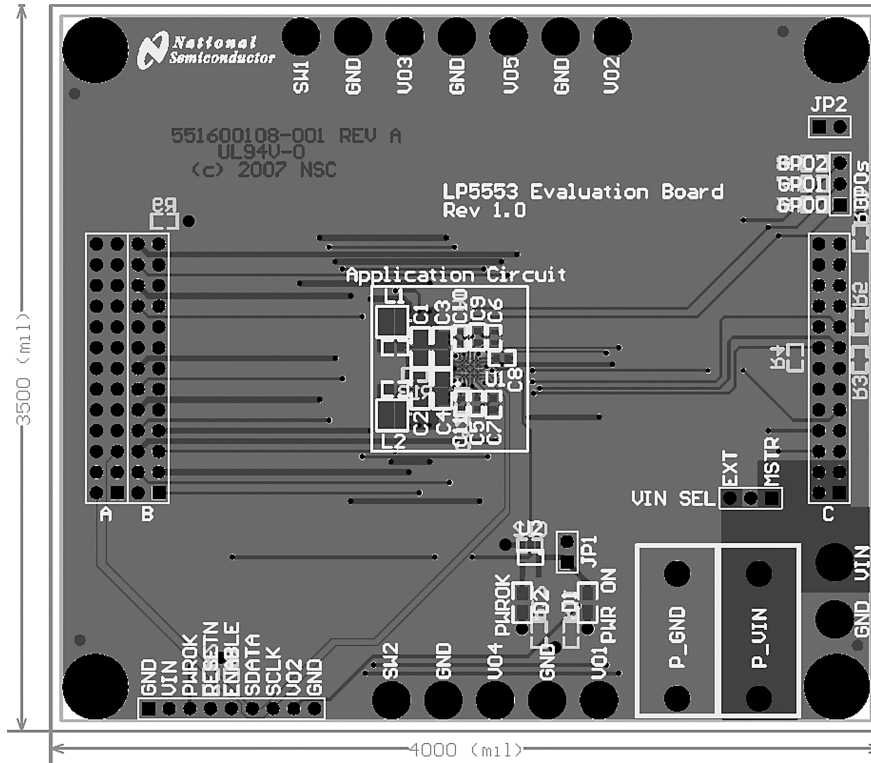

Figure 20. Composite View

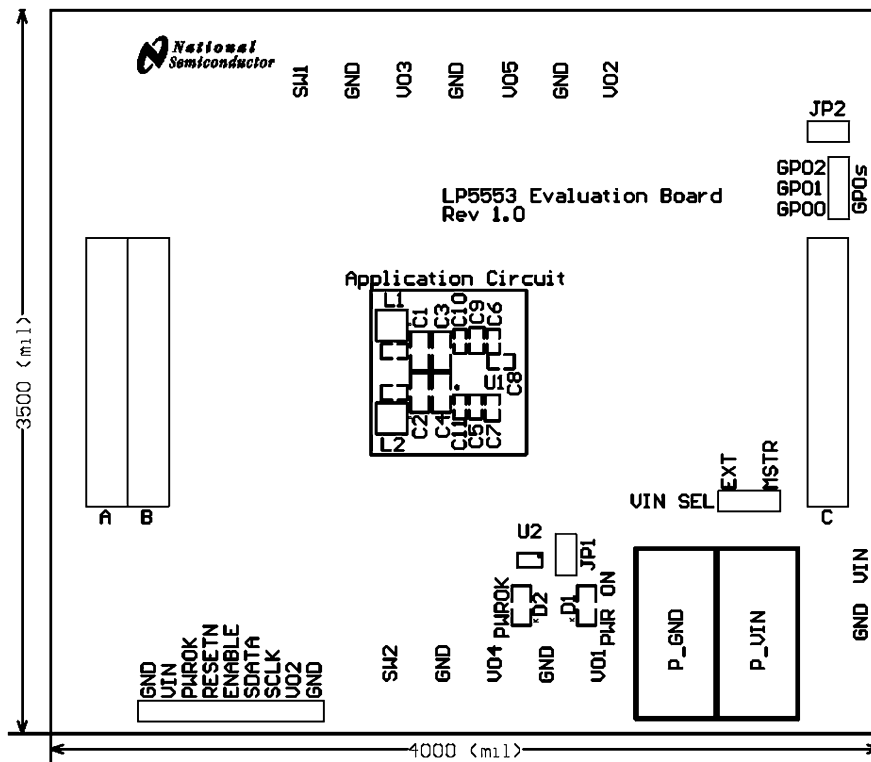

Figure 21. Top Silk Screen

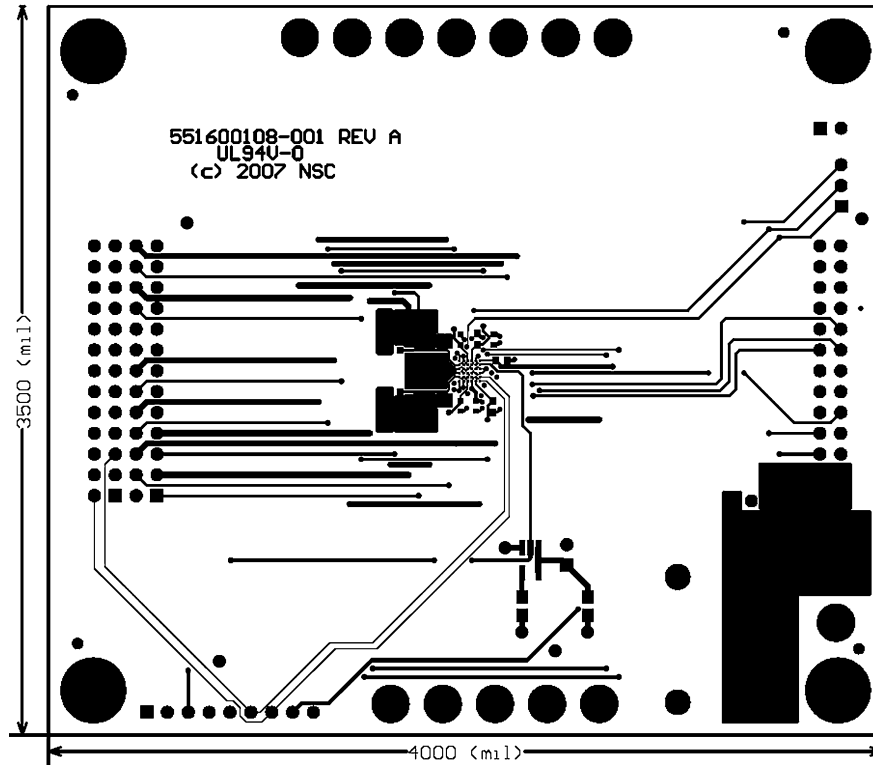

Figure 22. Top Layer

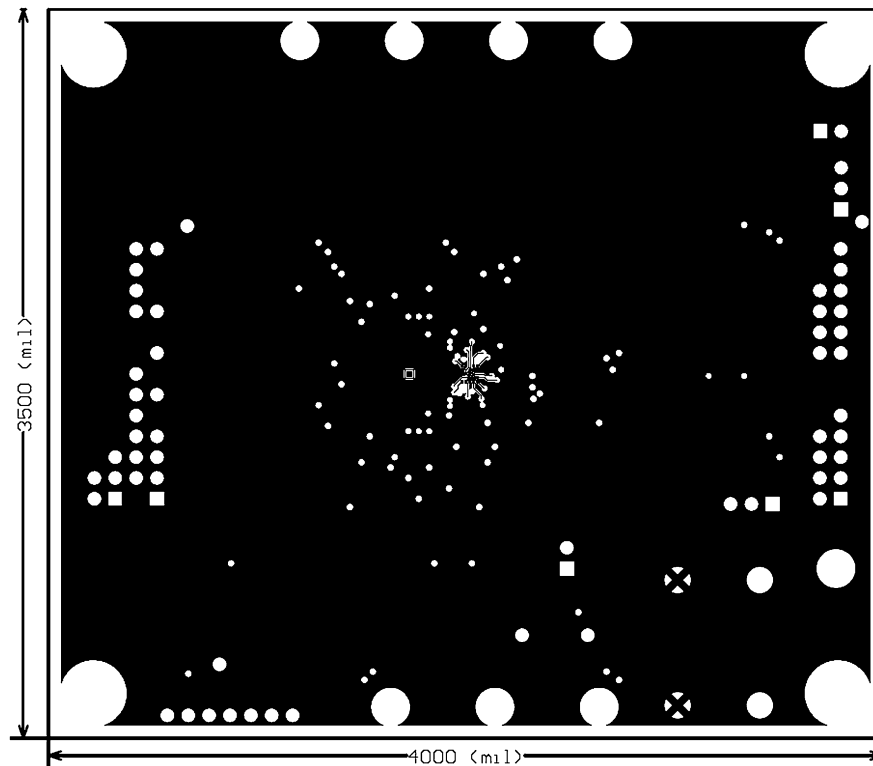

Figure 23. Layer 2, Ground Plane

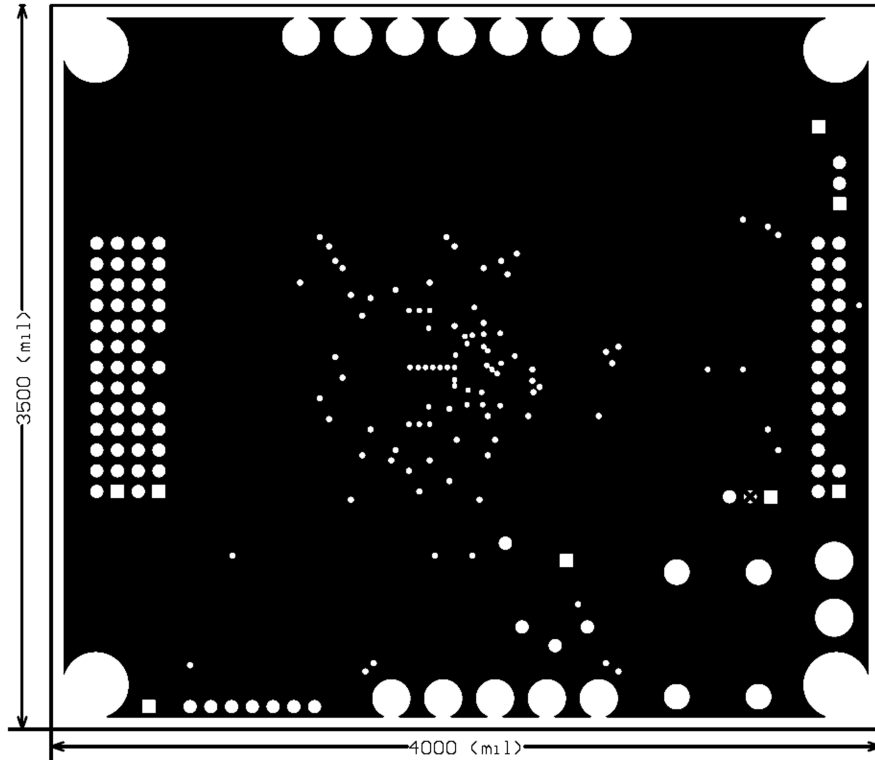

Figure 24. Layer 3, V_{IN} Plane

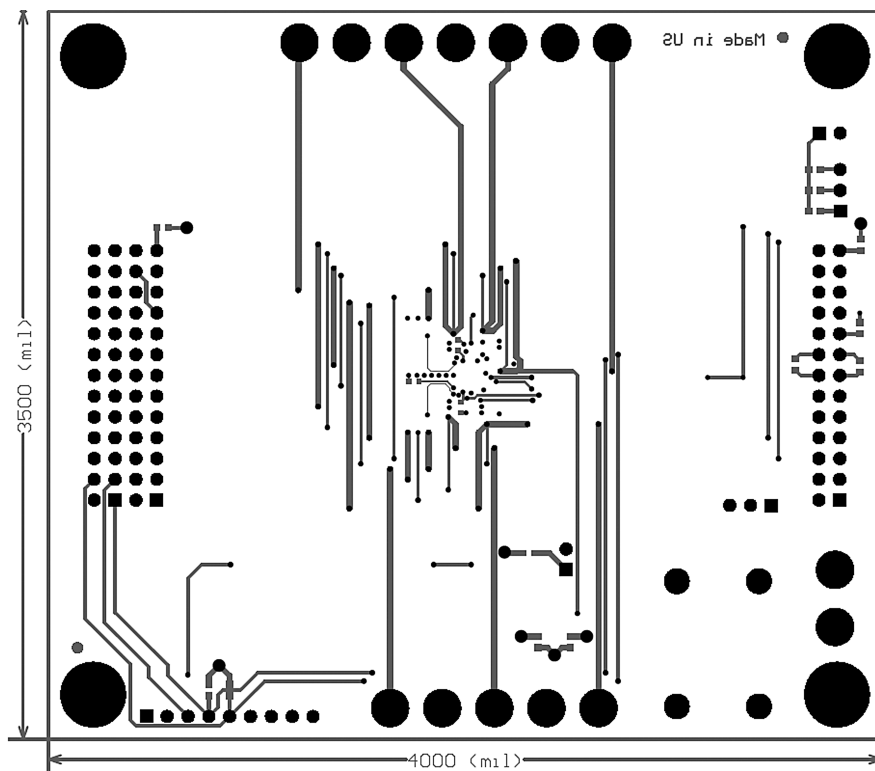

Figure 25. Bottom Layer

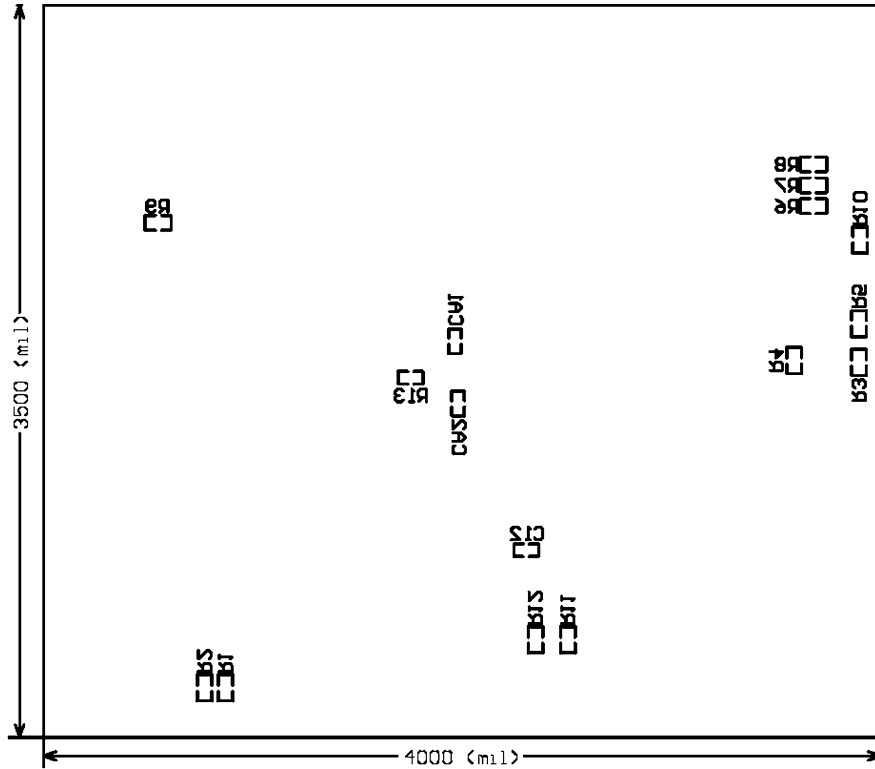

Figure 26. Bottom Silk Screen

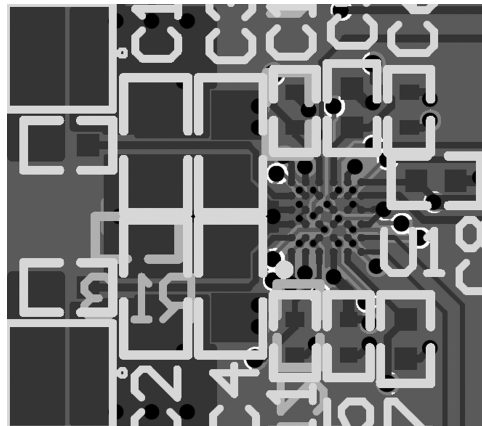

Figure 27. Compose View Close Up

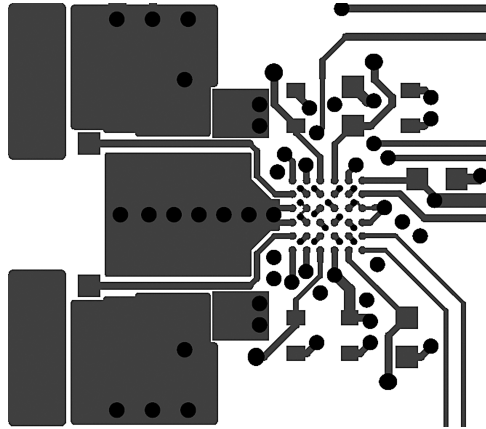

Figure 28. Top Layer Close Up

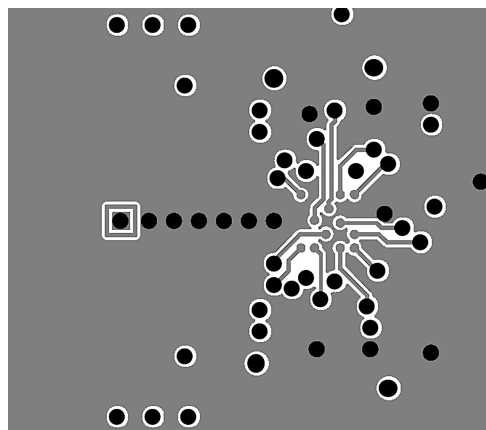

Figure 29. L2 Close Up

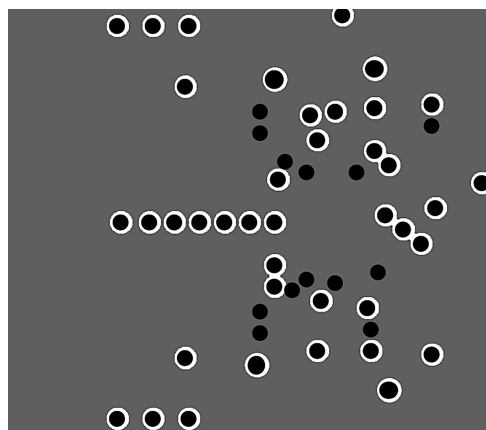
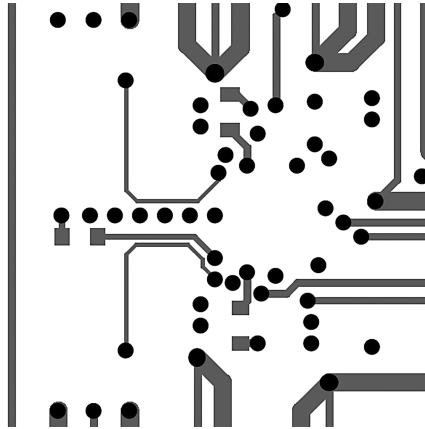

Figure 30. L3 Close Up

Figure 31. Bottom Layer Close up
Table 7. Bill of Materials (LP5553 Evaluation Board)

Designator	Part Value	P/N	Footprint	Description	Manufacturer
A	2x13 Pin Array	9-146252-0-13	DIP-26	Mainboard Connector	AMP/Tyco
B	2x13 Pin Array	9-146252-0-13	DIP-26	Mainboard Connector	AMP/Tyco
C	2x13 Pin Array	9-146252-0-13	DIP-26	Mainboard Connector	AMP/Tyco
CA1	NL		0402	AVDD1 Bypass Cap	N/A
CA2	NL		0402	AVDD2 Bypass Cap	N/A
C1	10 μ F	LMK212BJ106KD	0805	SW1 Output Cap	Taiyo Yuden
C2	10 μ F	LMK212BJ106KD	0805	SW2 Output Cap	Taiyo Yuden
C3	10 μ F	LMK212BJ106KD	0805	SW1 Input Cap	Taiyo Yuden
C4	10 μ F	LMK212BJ106KD	0805	SW2 Input Cap	Taiyo Yuden
C5	0.1 μ F/16V/X5R/10%		0402	General Bypass Cap	N/A
C6	0.1 μ F/16V/X5R/10%		0402	General Bypass Cap	N/A
C7	2.2 μ F/10V/X5R/10%		0603	LDO1 Output Cap	N/A
C8	4.7 μ F/10V/X5R/10%		0603	LDO2 Output Cap	N/A
C9	4.7 μ F/10V/X5R/10%		0603	LDO5 Output Cap	N/A
C10	1.0 μ F/10V/X5R/10%	LMK105BJ105KV	0402	LDO3 Output Cap	Taiyo Yuden
C11	1.0 μ F/10V/X5R/10%	LMK105BJ105KV	0402	LDO4 Output Cap	Taiyo Yuden
C12	0.1 μ F/16V/X5R/10%		0402	PWROK Buffer Bypass Cap	N/A
L1	1 μ H	LPS3010-102ML	LPS30xx	SW1 Output Inductor	Coilcraft
L2	1 μ H	LPS3010-102ML	LPS30xx	SW2 Output Inductor	Coilcraft
PWR_ON	Red LED	LTST-C171KRKT	0805	Red Power On Indicator	Lite-On
PWROK	Green LED	LTST-C170KGKT	0805	Green PWROK Indicator	Lite-On
R1	NL		0603	Pull-up for ENABLE	N/A
R2	NL		0603	Pull-up for RESETN	N/A
R3	10k/0.1W/5%		0603	SA1 Pull-down	N/A
R4	10k/0.1W/5%		0603	SA2 Pull-down	N/A
R5	10k/0.1W/5%		0603	SA3 Pull-down	N/A
R6	10k/0.1W/5%		0603	GPO0 Pull-up	N/A
R7	10k/0.1W/5%		0603	GPO1 Pull-up	N/A
R8	10k/0.1W/5%		0603	GPO2 Pull-up	N/A
R9	1.5k/0.1W/5%		0603	Mainboard Presence Detect	N/A

Table 7. Bill of Materials (LP5553 Evaluation Board) (continued)

Designator	Part Value	P/N	Footprint	Description	Manufacturer
R10	1.5k/0.1W/5%		0603	Mainboard Presence Detect	N/A
R11	240-ohm/0.1W/5%		0603	Red LED Current Limit Res.	N/A
R12	160-ohm/0.1W/5%		0603	Green LED Current Limit Res.	N/A
R13	0-ohm/0.063W/5%		0402	RGND Isolation Res.	N/A
SW1_O	0-ohm/0.1W/5%		0603	Measurement Pads SW1	N/A
SW2_O	0-ohm/0.1W/5%		0603	Measurement Pads SW2	N/A
U1	LP5553 PMIC	LP5553	μSMD-36	PMIC	TI
U2	Tri-State Buffer	NC7SZ126M5	SOT23-5	PWROK LED Buffer	Fairchild Semiconductor

REVISION HISTORY

Changes from Revision D (March 2013) to Revision E	Page
• Changed layout of National Data Sheet to TI format	41

PACKAGING INFORMATION

Orderable Device	Status (1)	Package Type	Package Drawing	Pins	Package Qty	Eco Plan (2)	Lead/Ball Finish (6)	MSL Peak Temp (3)	Op Temp (°C)	Device Marking (4/5)	Samples
LP5553TL/NOPB	OBSOLETE	DSBGA	YZR	36		TBD	Call TI	Call TI	-40 to 125		
LP5553TLX/NOPB	OBSOLETE	DSBGA	YZR	36		TBD	Call TI	Call TI	-40 to 125		

(1) The marketing status values are defined as follows:

ACTIVE: Product device recommended for new designs.

LIFEBUY: TI has announced that the device will be discontinued, and a lifetime-buy period is in effect.

NRND: Not recommended for new designs. Device is in production to support existing customers, but TI does not recommend using this part in a new design.

PREVIEW: Device has been announced but is not in production. Samples may or may not be available.

OBSOLETE: TI has discontinued the production of the device.

(2) Eco Plan - The planned eco-friendly classification: Pb-Free (RoHS), Pb-Free (RoHS Exempt), or Green (RoHS & no Sb/Br) - please check <http://www.ti.com/productcontent> for the latest availability information and additional product content details.

TBD: The Pb-Free/Green conversion plan has not been defined.

Pb-Free (RoHS): TI's terms "Lead-Free" or "Pb-Free" mean semiconductor products that are compatible with the current RoHS requirements for all 6 substances, including the requirement that lead not exceed 0.1% by weight in homogeneous materials. Where designed to be soldered at high temperatures, TI Pb-Free products are suitable for use in specified lead-free processes.

Pb-Free (RoHS Exempt): This component has a RoHS exemption for either 1) lead-based flip-chip solder bumps used between the die and package, or 2) lead-based die adhesive used between the die and leadframe. The component is otherwise considered Pb-Free (RoHS compatible) as defined above.

Green (RoHS & no Sb/Br): TI defines "Green" to mean Pb-Free (RoHS compatible), and free of Bromine (Br) and Antimony (Sb) based flame retardants (Br or Sb do not exceed 0.1% by weight in homogeneous material)

(3) MSL, Peak Temp. - The Moisture Sensitivity Level rating according to the JEDEC industry standard classifications, and peak solder temperature.

(4) There may be additional marking, which relates to the logo, the lot trace code information, or the environmental category on the device.

(5) Multiple Device Markings will be inside parentheses. Only one Device Marking contained in parentheses and separated by a "~" will appear on a device. If a line is indented then it is a continuation of the previous line and the two combined represent the entire Device Marking for that device.

(6) Lead/Ball Finish - Orderable Devices may have multiple material finish options. Finish options are separated by a vertical ruled line. Lead/Ball Finish values may wrap to two lines if the finish value exceeds the maximum column width.

Important Information and Disclaimer: The information provided on this page represents TI's knowledge and belief as of the date that it is provided. TI bases its knowledge and belief on information provided by third parties, and makes no representation or warranty as to the accuracy of such information. Efforts are underway to better integrate information from third parties. TI has taken and continues to take reasonable steps to provide representative and accurate information but may not have conducted destructive testing or chemical analysis on incoming materials and chemicals. TI and TI suppliers consider certain information to be proprietary, and thus CAS numbers and other limited information may not be available for release.

In no event shall TI's liability arising out of such information exceed the total purchase price of the TI part(s) at issue in this document sold by TI to Customer on an annual basis.

YZR0036

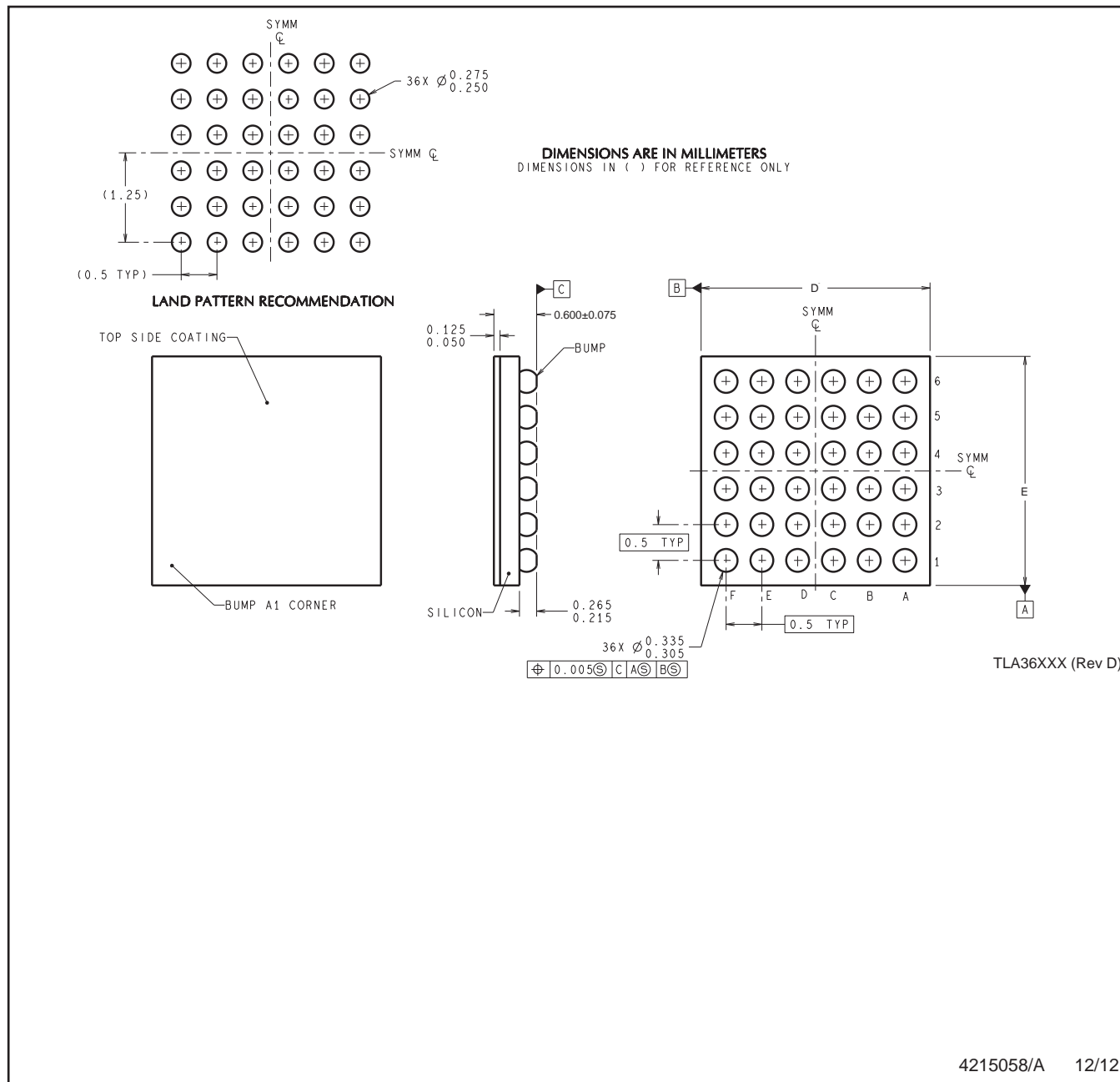

4215058/A 12/12

NOTES: A. All linear dimensions are in millimeters. Dimensioning and tolerancing per ASME Y14.5M-1994.
B. This drawing is subject to change without notice.

IMPORTANT NOTICE

Texas Instruments Incorporated and its subsidiaries (TI) reserve the right to make corrections, enhancements, improvements and other changes to its semiconductor products and services per JESD46, latest issue, and to discontinue any product or service per JESD48, latest issue. Buyers should obtain the latest relevant information before placing orders and should verify that such information is current and complete. All semiconductor products (also referred to herein as "components") are sold subject to TI's terms and conditions of sale supplied at the time of order acknowledgment.

TI warrants performance of its components to the specifications applicable at the time of sale, in accordance with the warranty in TI's terms and conditions of sale of semiconductor products. Testing and other quality control techniques are used to the extent TI deems necessary to support this warranty. Except where mandated by applicable law, testing of all parameters of each component is not necessarily performed.

TI assumes no liability for applications assistance or the design of Buyers' products. Buyers are responsible for their products and applications using TI components. To minimize the risks associated with Buyers' products and applications, Buyers should provide adequate design and operating safeguards.

TI does not warrant or represent that any license, either express or implied, is granted under any patent right, copyright, mask work right, or other intellectual property right relating to any combination, machine, or process in which TI components or services are used. Information published by TI regarding third-party products or services does not constitute a license to use such products or services or a warranty or endorsement thereof. Use of such information may require a license from a third party under the patents or other intellectual property of the third party, or a license from TI under the patents or other intellectual property of TI.

Reproduction of significant portions of TI information in TI data books or data sheets is permissible only if reproduction is without alteration and is accompanied by all associated warranties, conditions, limitations, and notices. TI is not responsible or liable for such altered documentation. Information of third parties may be subject to additional restrictions.

Resale of TI components or services with statements different from or beyond the parameters stated by TI for that component or service voids all express and any implied warranties for the associated TI component or service and is an unfair and deceptive business practice. TI is not responsible or liable for any such statements.

Buyer acknowledges and agrees that it is solely responsible for compliance with all legal, regulatory and safety-related requirements concerning its products, and any use of TI components in its applications, notwithstanding any applications-related information or support that may be provided by TI. Buyer represents and agrees that it has all the necessary expertise to create and implement safeguards which anticipate dangerous consequences of failures, monitor failures and their consequences, lessen the likelihood of failures that might cause harm and take appropriate remedial actions. Buyer will fully indemnify TI and its representatives against any damages arising out of the use of any TI components in safety-critical applications.

In some cases, TI components may be promoted specifically to facilitate safety-related applications. With such components, TI's goal is to help enable customers to design and create their own end-product solutions that meet applicable functional safety standards and requirements. Nonetheless, such components are subject to these terms.

No TI components are authorized for use in FDA Class III (or similar life-critical medical equipment) unless authorized officers of the parties have executed a special agreement specifically governing such use.

Only those TI components which TI has specifically designated as military grade or "enhanced plastic" are designed and intended for use in military/aerospace applications or environments. Buyer acknowledges and agrees that any military or aerospace use of TI components which have **not** been so designated is solely at the Buyer's risk, and that Buyer is solely responsible for compliance with all legal and regulatory requirements in connection with such use.

TI has specifically designated certain components as meeting ISO/TS16949 requirements, mainly for automotive use. In any case of use of non-designated products, TI will not be responsible for any failure to meet ISO/TS16949.

Products

Audio	www.ti.com/audio
Amplifiers	amplifier.ti.com
Data Converters	dataconverter.ti.com
DLP® Products	www.dlp.com
DSP	dsp.ti.com
Clocks and Timers	www.ti.com/clocks
Interface	interface.ti.com
Logic	logic.ti.com
Power Mgmt	power.ti.com
Microcontrollers	microcontroller.ti.com
RFID	www.ti-rfid.com
OMAP Applications Processors	www.ti.com/omap
Wireless Connectivity	www.ti.com/wirelessconnectivity

Applications

Automotive and Transportation	www.ti.com/automotive
Communications and Telecom	www.ti.com/communications
Computers and Peripherals	www.ti.com/computers
Consumer Electronics	www.ti.com/consumer-apps
Energy and Lighting	www.ti.com/energy
Industrial	www.ti.com/industrial
Medical	www.ti.com/medical
Security	www.ti.com/security
Space, Avionics and Defense	www.ti.com/space-avionics-defense
Video and Imaging	www.ti.com/video

TI E2E Community

e2e.ti.com