

## High Efficiency 2.5A/28V Boost DC/DC Convertor

### General Description

The LP6230 is a current mode boost DC-DC converter. Its PWM circuitry with built-in 0.12Ω, 28V, 2.5A Current power MOSFET makes this converter highly power efficiently. Selectable high switching frequency allows faster loop response and easy filtering with a low noise output. The non-inverting input its error amplifier is connected to an internal 1.25V precision reference voltage. Soft-Start time can be programmed with an external capacitor, which sets the input current ramp rate. Current mode control and external compensation network make it easy and flexible to stabilize the system.

### Ordering Information

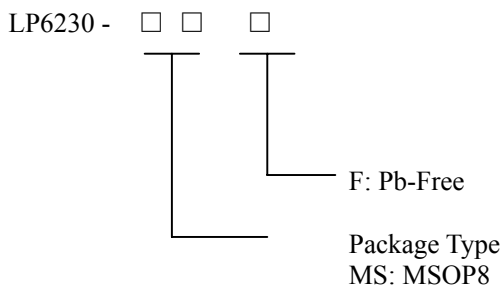

### Typical Application Circuit

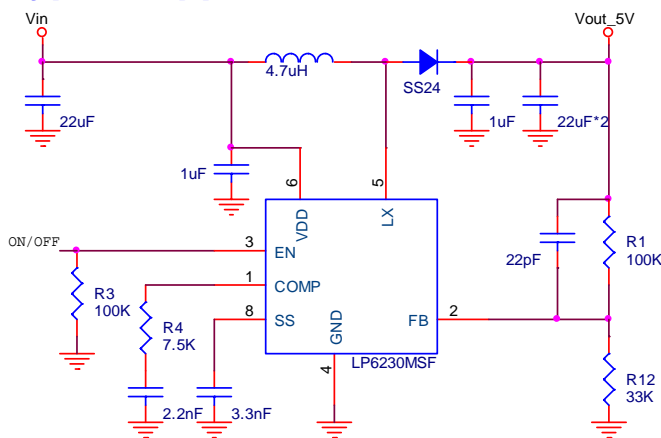

### Features

- ◆ Up to 94% efficiency
- ◆ Output to Input Disconnect at Shutdown Mode
- ◆ Shut-down current: <1uA
- ◆ Output voltage Up to 28V
- ◆ Internal Compensation
- ◆ 1.2MHz fixed frequency switching
- ◆ High switch on current: 2.5A/30V
- ◆ Available in MSOP8 Package

### Applications

- ◇ Battery products
- ◇ Host Products
- ◇ Panel

### Pin Configurations

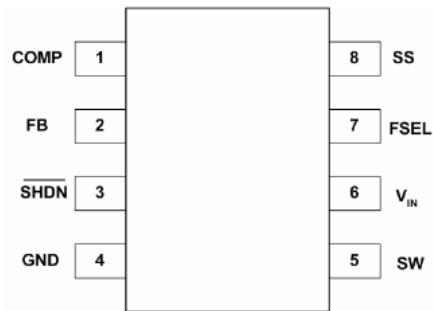

### Marking Information

Please see website: [www.lowpowersemi.com](http://www.lowpowersemi.com).

### Functional Pin Description

PIN	PIN Name	Description
1	COMP	Error Amplifier Compensation Output.
2	FB	Regulation Feedback Input. Connect to an external resistive voltage divider from the output to FB to set the output voltage.
3	EN	Regulator On/off Control Input. A logic high input(VEN>1.4V) turns on the regulator. A logic low input(VEN<0.4V) puts the LP6230 into low current shutdown mode.
4	GND	Ground.
5	SW/LX	Output switching node. SW is the drain of the internal low-side N-Channel MOSFET and high-side P-Channel MOSFET. Connect the inductor to SW to Complete the step-up converter.
6	VIN	Power Supply pin.
7	FSEL/NC	No Connector, The Frequency switching is 1.2MHz.
8	SS	Soft Star pin.

### Function Block Diagram

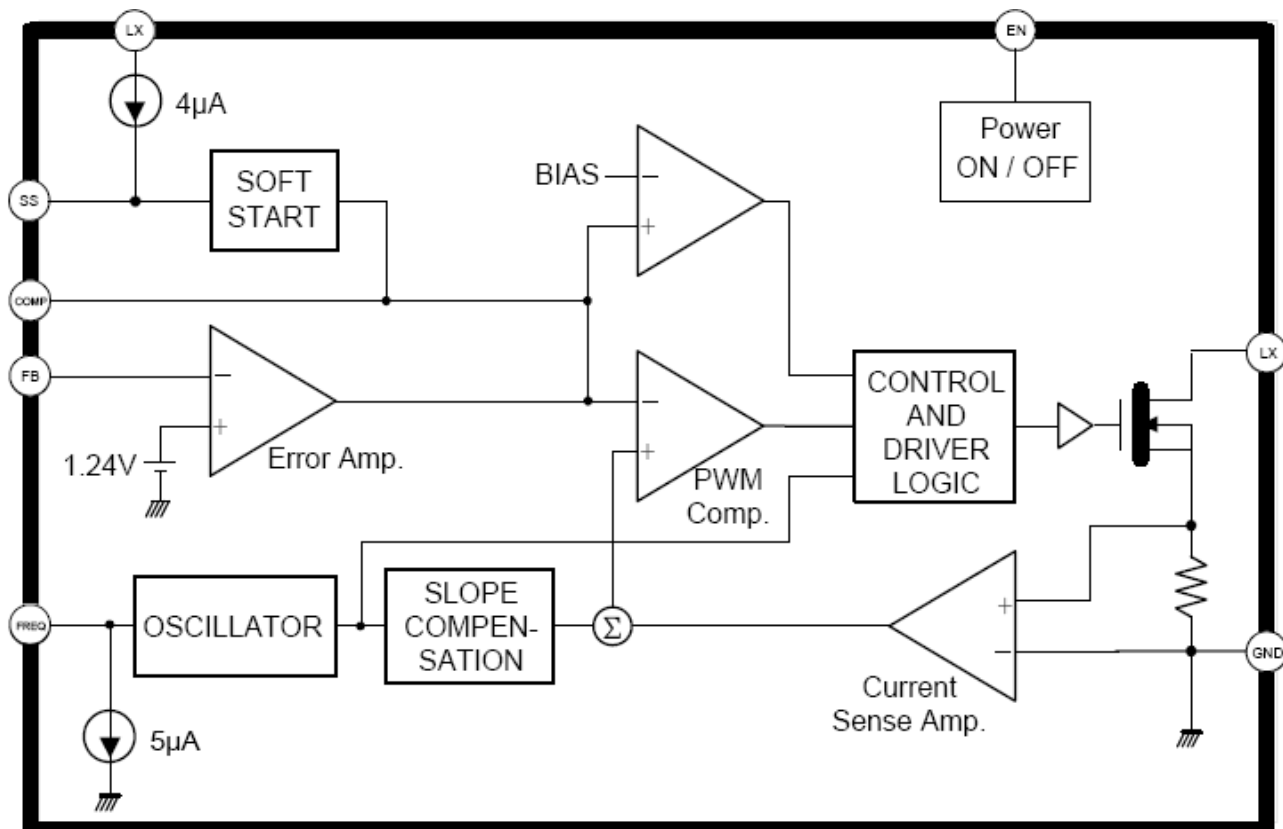

## Absolute Maximum Ratings

Supply Input Voltage-----6V  
 Power Dissipation, PD @ TA = 25° C  
 MSOP8-----900mW  
 Package Thermal Resistance  
 MSOP8,  $\theta_{JA}$  -----165°C/W  
 Lead Temperature (Soldering, 10 sec.) -----260°C

### Recommended Operating Conditions

Supply Input Voltage-----2.2V to 6V  
 EN Input Voltage -----0V to 5.5V  
 Operation Junction Temperature Range -----40°C to 125°C  
 Operation Ambient Temperature Range-----40°C to 85°C

## Electrical Characteristics

(Vin=2.4V, Vout=3.5V, Cin=10uF, Cout=22uF, L1=4.7uH, R1=178K, R2=100K)

Parameter	Conditions	LP6230			Units
		Min	Typ	Max	
Supply Voltage		2.2		5	V
Output Voltage Range		2.5		28	V
Supply Current(Shutdown)	VEN=VOUT=0V, VSW=5V		0.05	1	uA
Supply Current	VFB=1.3V		0.39		mA
Feedback Voltage		1.22	1.25	1.28	V
Feedback Input Current	VFB=1.2V		50		nA
Switching Frequency			1200		KHz
Maximum Duty Cycle		80	90	95	%
EN Input Low Voltage				0.4	V
EN Input High Voltage		1.4			V
EN Pull Down Resistance			1		MΩ
Low-side On Resistance	Vout=3.3V		450		mΩ
Low-side Current Limit			2.5		A
High-side On Resistance	Vout=3.3V		120		mΩ
Mosfet Voltage			30		V

Typical Operating Characteristics

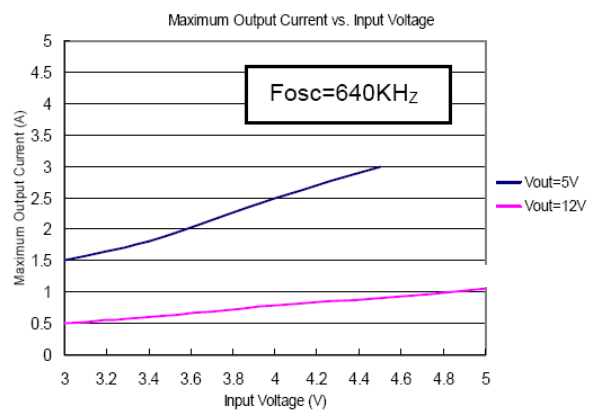
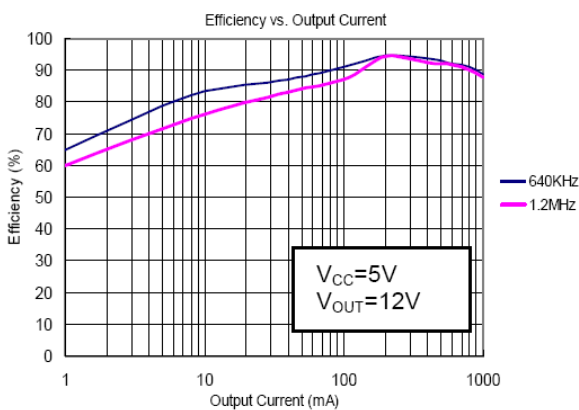
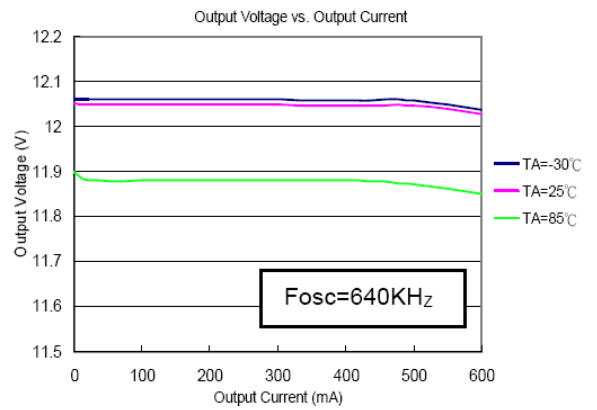
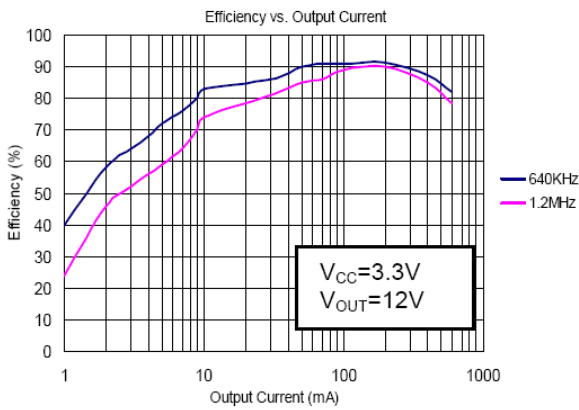
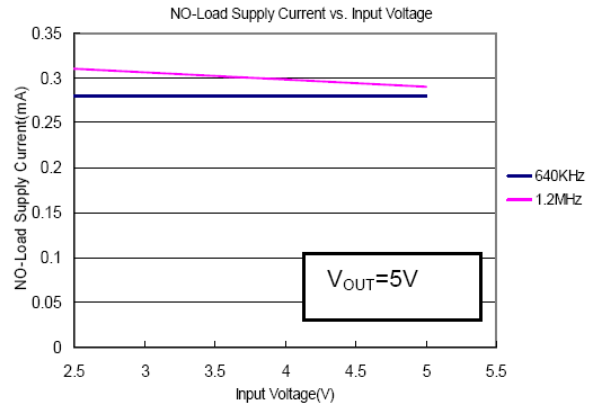
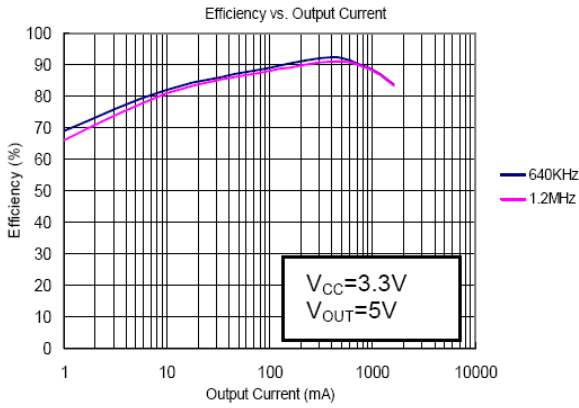

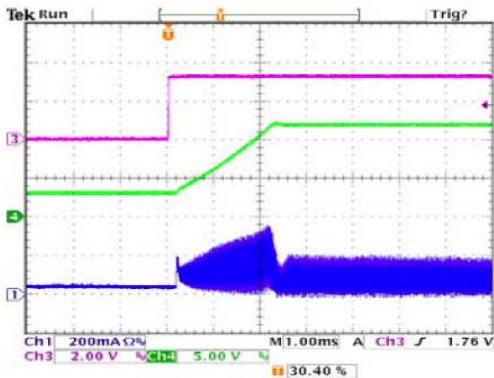

CH1=Inductor Current,CH4=  $V_{OUT}$   
 $V_{CC}=3.3V$ ,  $V_{OUT}=12V$   
 $I_{LOAD}=10mA$   
 Frequency=640KHz

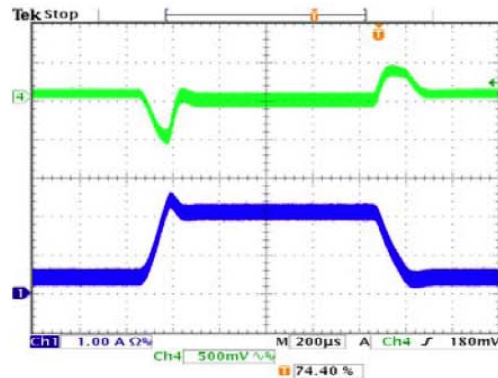

CH1=Inductor Current,CH3=EN,CH4= $V_{OUT}$   
 $V_{CC}=3.3V$ ,  $V_{OUT}=12V$   
 $I_{LOAD}=100mA\sim 500mA$   
 Frequency=640KHz

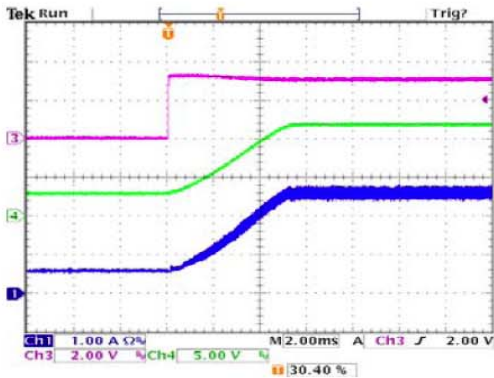

CH1=Inductor Current,CH3=EN,CH4= $V_{OUT}$   
 $V_{CC}=3.3V$ ,  $V_{OUT}=12V$   
 $I_{LOAD}=600mA$   
 Freq=640KHz

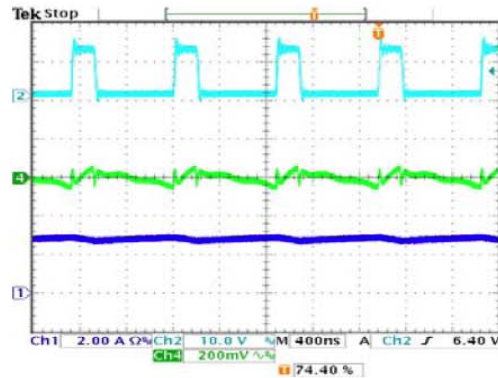

CH1=Inductor Current,CH3=LX,CH4=  $V_{OUT}$   
 AC-Coupled  
 $V_{CC}=3.3V$ ,  $V_{OUT}=12V$   
 $I_{LOAD}=600mA$   
 Freq=1.2MHz

### Operation Information

The LP6230 uses a 640K/1200KHz fixed-frequency, current-mode regulation architecture to regulate the output voltage. The LP6230 measures the output voltage through an external resistive voltage divider and compares that to the internal 1.25V reference to generate the error voltage to the inductor current to regulate the output voltage. The use of current-mode regulation improves transient response and control loop stability. When the LP6230 is disabled (EN=Low), both power switches are off. There is no current path from SW to OUT. Therefore, the output voltage discharges to ground. When the LP6230 is enabled (EN=High), a limited start-current charges the output voltage rising to SW, then the part operates in force PWM mode for regulating the output voltage to the target value. At the beginning of each cycle, the N-channel MOSFET switch is turned on, forcing the inductor current to rise. The current at the source of the switch is internally measured and converted to a voltage by the current sense amplifier. That voltage is compared to the error voltage. When the inductor current rises sufficiently, the PWM comparator turns off the switch, forcing the inductor current to the output capacitor through the internal P-Channel MOSFET rectifier, which forces the inductor current to decrease. The peak inductor current is controlled by the error voltage. Thus the output voltage controls the inductor current to satisfy the load.

### Setting the Output Voltage

Set the output voltage by selecting the resistive voltage divider ratio. The voltage divider drops the output voltage to the 1.25V feedback voltage. Use a

100K resistor for R2 of the voltage divider. Determine the high-side resistor R1 by the equation:  
 $V_{out} = (R1/R2 + 1) \times V_{FB}$

### Application Information

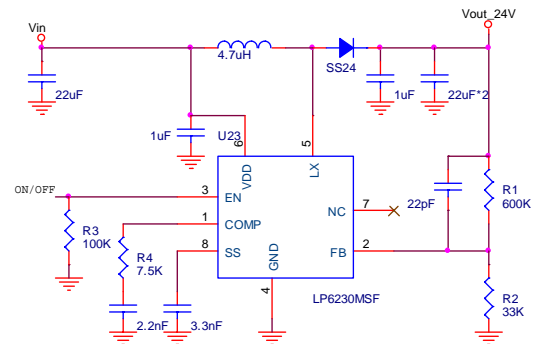

Figure1. LP6230MSF Output 24V with Li-ion Battery

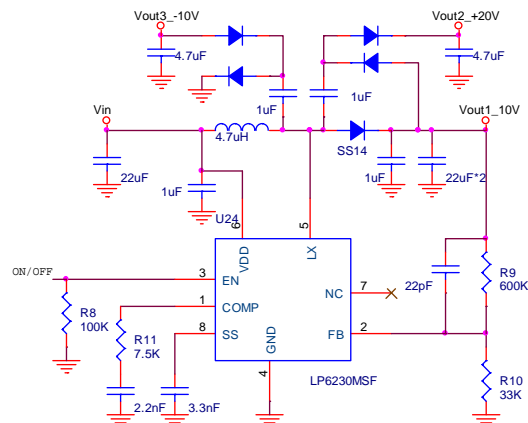
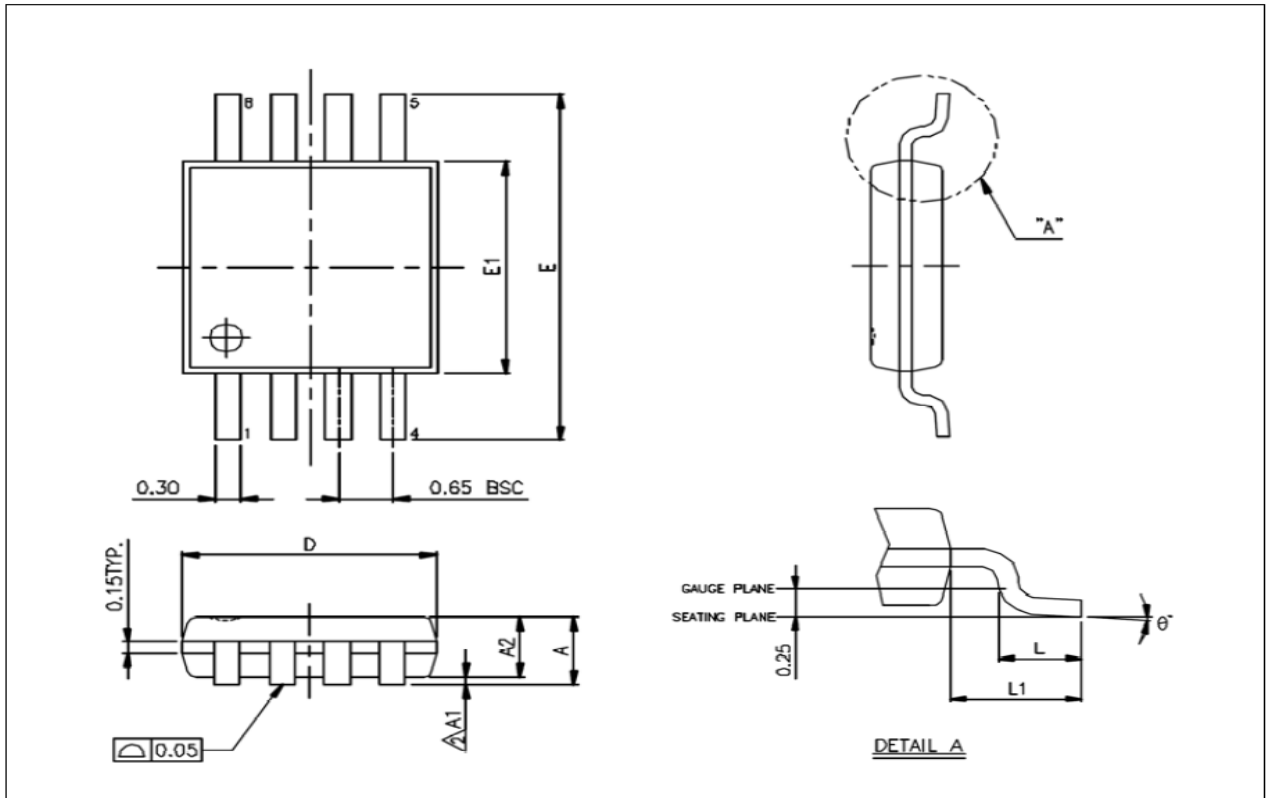

Figure2. LP6230MSF For Panel application with Li-ion Battery

## Packaging Information

### MSOP-8L



Unit: mm

Symbols	Min. (mm)	Max. (mm)
A		1.100
A1	0.000	0.150
A2	0.750	0.950
D	3.000 BSC	
E	4.900 BSC	
E1	3.000 BSC	
L	0.400	0.800
L1	0.950 REF	
$\theta^\circ$	0°	8°

**Note:**

1. Package dimensions are in compliance with JEDEC outline: MO-187 AA.
2. Dimension "D" does not include molding flash, protrusions or gate burrs.
3. Dimension "E1" does not include inter-lead flash or protrusions.