



Document Name	Document No.	Ver	Date	Page
LP904374F Specification	ZJQM-RD-SPC-A01523	0.0	2015-10-14	1/9

EEMB CO., LTD

Lithium Iron Phosphate Battery Specification

磷酸铁锂电池

产品规格书

Model 型号:	LP904374F
Capacity 容量:	2100mAh

Prepared 编制	Checked 审核	Approved 批准

Customer 客户名称:

Customer Approval (Customer confirmation) 客户确认:

Signature 签字	Checked 审核	Approved 批准

Address: Room ABCD, 25/F, Block A, Fortune Plaza, NO.7060 Shennan Road Shenzhen, China

Postal code: 518040

Phone: 0086-755-83022275

FAX: 0086-755-83021966

<http://www.eemb.com>

Document Name	Document No.	Ver	Date	Page
LP904374F Specification	ZJQM-RD-SPC-A01523	0.0	2015-10-14	2/9

Catalog

Chapter	Content	Page
0	Catalog.....	2
1	Scope.....	3
2	Battery Cell Basic Characteristics.....	3
2.1	Model.....	3
2.2	Capacity.....	3
2.3	Nominal Voltage.....	3
2.4	Weight.....	3
2.5	Internal Impedance.....	3
2.6	Dimension.....	3
2.7	Charge.....	3
2.8	Discharge.....	3
2.9	Operation Temperature.....	3
2.10	Storage Temperature.....	3
2.11	Storage Relative Humidity.....	3
3	Battery Cell Shape and Dimensions.....	4
4	Appearance.....	4
5	Battery Cell Specification.....	4
5.1	Electrical Characteristics.....	4
5.1.1	1C ₅ A Rate Discharge Capacity.....	4
5.1.2	High Temp. Discharge Capacity.....	4
5.1.3	Low Temp. Discharge Capacity.....	4
5.1.4	Cycle Life.....	5
5.1.5	Capacity Retention.....	5
5.2	Acclimatization Characteristics.....	5
5.2.1	High Temp. and High Humidity.....	5
5.2.2	Vibration.....	5
5.2.3	Drop.....	5
5.2.4	Low-pressure.....	5
5.3	Safety Characteristics.....	6
5.3.1	Overcharge.....	6
5.3.2	Short-Circuit.....	6
5.3.3	Heating.....	6
5.3.4	Temperature Cycle.....	6
6	Battery Shipping Voltage.....	6
7	Warranty.....	7
8	Matters Needing Attention.....	7~9

Document Name	Document No.	Ver	Date	Page
LP904374F Specification	ZJQM-RD-SPC-A01523	0.0	2015-10-14	3/9

1. Scope 适用范围

This product specification defines the requirements of the rechargeable lithium iron phosphate battery supplied to the customer by EEMB Co., Ltd.

本产品规格书适用于 EEMB 提供的磷酸铁锂电池

2. Battery Cell Basic Characteristics 电芯产品基本特性

No.	Item 项目	Characteristics 性能指标	Remark 备注	
2.1	Model 型号	LP904374F		
2.2	Capacity 容量	Nominal 标称容量	2100 mAh	0.2C ₅ A
		Minimum 最小容量	2000 mAh	0.2C ₅ A
2.3	Nominal Voltage 额定电压	3.2 V		
2.4	Weight 重量	Approx. 52.5 g		
2.5	Internal Impedance 内阻	≤ 70 mΩ	AC 1KHz(50% charge)	
2.6	Dimension 外形尺寸	Length 长	≤ 75 mm	
		Width 宽	≤ 43.5 mm	
		Thickness 主体厚	≤ 9.3 mm	
2.7	Charge 充电	Maximum Current 最大充电电流	2100 mA	1C ₅ A (CC&CV)
		Limited Voltage 充电上限电压	3.650±0.020 V	
		End-of Current 充电截至电流	42 mA	
2.8	Discharge 放电	Maximum Current 最大放电电流	4200 mA	2.0C ₅ A
		Cut-off Voltage 放电终止电压	2.000±0.005 V	
2.9	Operation Temperature 工作温度	Charge 充电温度	0 ~ 45 °C	
		Discharge 放电温度	-10 ~ +60 °C	
2.10	Storage Temperature 贮存温度	1 month 1 个月 (贮存期)	-20 ~ +60 °C	
		3 months 3 个月 (贮存期)	-20 ~ +45 °C	
		12 months 12 个月 (贮存期)	-20 ~ +25 °C	
2.11	Storage Relative Humidity 贮存湿度	65±20 %		

Document Name	Document No.	Ver	Date	Page
LP904374F Specification	ZJQM-RD-SPC-A01523	0.0	2015-10-14	4/9

3. Battery Cell Shape and Dimensions (Unit: mm)

产品外形及尺寸 (单位: mm)

Item 项目	Specification 规格
T	Max9.3
W	Max43.5
L	Max75
L1	Max76
L2	10±1
M	25±1
N	4±0.5

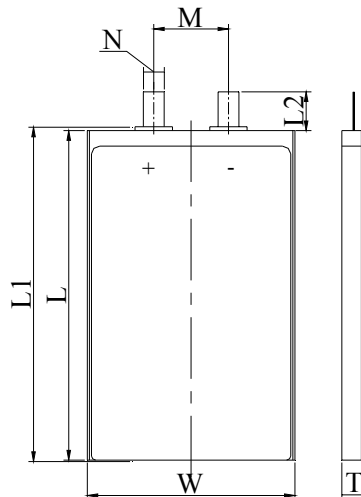

4. Appearance 外观

It shall be free from any defects such as remarkable scratches, breaks, cracks, discoloration, leakage, or middle deformation.

电池表面无划伤、裂纹、脏点、锈蚀、变形、变色、漏液等缺陷，中间无翘起

5. Battery Cell Specification 电池性能测试规范

5.1 Electrical Characteristics 电学性能

No.	Item 项目	Criteria 标准	Test Instructions 测试方法
5.1.1	1C ₅ A rate discharge capacity 1C ₅ A 放电容量	Discharge Capacity ≥ Minimum Capacity 放电容量 ≥ 最小容量	Full charge at 20±5°C, rest for 30 min, then discharge at the same temperature with 1.0C ₅ A to 2.0V. 电池在 20±5°C 完全充电后放置半小时后用 1C ₅ A 恒流放电至电池两端电压为 2.0V 时止记录放电容量。
5.1.2	High temp. discharge capacity 高温性能	Discharge Time ≥ 54min 放电时间 ≥ 54min	Full charge at 20±5°C, store at 55±2°C for 2h, then discharge at the same temperature with 1.0C ₅ A to 2.0V. 电池在 20±5°C 完全充电后放入 55±2°C 的高温箱中恒温 2h, 然后在同一温度下以 1.0C ₅ A 电流放电至 2.0V 记录放电时间。
5.1.3	Low temp. discharge capacity 低温性能	Discharge Time ≥ 3h 放电时间 ≥ 3h	Full charge at 20±5°C, store at -10°C±2°C for 16h~24h, then discharge at the same temperature with 0.2C ₅ A to 2.0V 电池在 20±5°C 完全充电后放入 -10±2°C 的低温箱中恒温 16~24h, 然后在同一温度下以 0.2C ₅ A 电流放电至 2.0V 记录放电时间。

Document Name	Document No.	Ver	Date	Page
LP904374F Specification	ZJQM-RD-SPC-A01523	0.0	2015-10-14	5/9

5.1.4	Cycle life 循环寿命	≥ 2000 cycles (0.5C ₅ A) ≥ 2000 次 (0.5C ₅ A)	Lay aside for 10 min after fully charged. Then discharge at constant current of 0.5C ₅ A to 2.0V and leave it for 10 minutes. Repeat above steps till retained discharge time is 84min. 电池完全充电后搁置 10min, 然后以 0.5C ₅ A 电流放电至 2.0V, 搁置 10min。重复上述步骤直到连续两次循环的放电时间均少于 84min 时寿命即为终止。
5.1.5	Capacity Retention 荷电保持能力	Discharge Time ≥ 4.5 h 放电时间 ≥ 4.5 h	After full charge, store at 20 \pm 5 $^{\circ}$ C for 28 days. Then discharge with 0.2C ₅ A to 2.0V 电池完全充电后在温度为 20 \pm 5 $^{\circ}$ C 条件下将电池开路搁置 28 天后, 以 0.2C ₅ A 电流放电至 2.0V 记录放电时间。

5.2 Acclimatization Characteristics 环境适应性能

No.	Item 项目	Criteria 标准	Test Instructions 测试方法
5.2.1	High Temp. And High Humidity 恒定湿热性能	No deformation, no rust, no fire or explosion; Discharge time ≥ 36 min 电池外观应无明显变形、锈蚀、冒烟或爆炸, 放电时间应不低于 36 min。	After full charge, store at 40 $^{\circ}$ C \pm 2 $^{\circ}$ C (90%~95%RH) for 48h. After test, place at 20 $^{\circ}$ C \pm 5 $^{\circ}$ C for 2h and then discharge with 1C ₅ A to end-voltage 电池完全充电后在 40 $^{\circ}$ C \pm 2 $^{\circ}$ C, 相对湿度为 90%~95%的恒温恒湿箱中搁置 48h 后, 将电池取出在环境温度 20 $^{\circ}$ C \pm 5 $^{\circ}$ C 的条件下搁置 2h, 然后 1C ₅ A 电流放电至终止电压。
5.2.2	Vibration 振动	No damnification, leakage, no fire or explosion; Battery Voltage ≥ 3.2 V 电池外观应无明显损伤、漏液、冒烟或爆炸, 电池电压应不低于 3.2V	Batteries are vibrated 30 min in three mutually perpendicular directions with amplitude of 0.38mm (10~30Hz) or 0.19mm (30~55Hz) and the scanning rate of 1oct per min 在三个相互垂直的方向按单振幅 0.38mm (振动频率 10~30Hz)、0.19mm (振动频率 30~55Hz) 循环扫描振动 30min, 扫频速度为 1oct/min。
5.2.3	Drop 自由跌落	No leakage, no fire or explosion; Discharge Time ≥ 51 min 电池应不漏液、不冒烟、不爆炸; 放电时间应不低于 51 min。	Batteries are dropped onto a hard board with the thickness of 18~20mm from 1meter from X, Y, Z direction of the positive and negative (six directions) and then discharge with 1C ₅ A to end-voltage, 电池由高度 (最低点高度) 为 1000mm 的位置自由跌落到置于水泥地面上的 18mm~20mm 厚的硬木板上, 从 X、Y、Z 正负方向 (六个方向) 每个方向自由跌落 1 次。自由跌落结束后, 将电池以 1C ₅ A 电流放电至终止电压
5.2.4	Low-pressure 低气压	No leakage, no fire or explosion 电池应不漏液、不起火、不爆炸	Put the batteries in a sealed vacuum and reduce internal pressure gradually to lower than 11.6 kpa. Keep for 6h 将电芯搁置在真空箱中, 真空箱密封后, 逐渐减少其内部压力至不高于 11.6kpa 并保持 6h

Document Name	Document No.	Ver	Date	Page
LP904374F Specification	ZJQM-RD-SPC-A01523	0.0	2015-10-14	6/9

5.3 Safety Characteristics 安全性能

No.	Item 项目	Criteria 标准	Test Instructions 测试方法
5.3.1	Overcharge 过充电	No fire or explosion 电池应不爆炸、不起火。	Charged the cells at 3C ₅ A current 20±5℃ with a voltage limit of 4.8V and end the test when current drops close to 0 A 将接有热电偶的电池置于通风橱中，接正负极于恒流恒压源，调节电流至 3C ₅ A、电压为 4.8V。然后对电池以 3C ₅ A 充电，直至电池电压为 4.8V，当电流降到接近于 0A，结束试验。
5.3.2	Short-Circuit 短路	No fire or explosion; The maximum Temperature: 150℃. 电池不起火、不爆炸。电池外表面温度不超过 150℃。	Place the battery with thermocouple into a fume hood, and short-circuit by connecting the positive and negative terminals (resistance load of 0.1Ω), monitoring the battery temperature changes in the course of test. End the test when the battery temperature drops to about 10℃ lower than peak value. 将接有热电偶的电池置于通风橱中，短路其正负极（线路总电阻 100mΩ），试验过程中监视电池温度变化。当电池温度下降到比峰值低约 10℃时，结束试验。
5.3.3	Thermal abuse 热滥用	No fire or explosion 电池应不起火、不爆炸。	Cell is heated in a circulating air oven at a rate of (5±2)℃ per minute to 130±2℃, and then placed for 30 minutes at 130±2℃ 电池放置于热箱中，温度以 (5±2℃)/min 的速率升至 130±2℃ 并保温 30min。
5.3.4	Temperature cycle 温度循环	No leakage, no fire or explosion 电池应不泄露，不起火，不爆炸	After full charge, place the battery in the temperature control box of 20±5℃, do the following steps: (1)Put the battery into test chamber of 75℃±2℃ and keep for 6h. (2)Lower the temperature to -40±2℃ and keep for 6h (3)Temperature conversion time is no longer than 30 min (4)Repeat the above three steps for 10 cycles. 将电池充满电后，将电池放置在温度为 20℃±5℃ 的温控箱中进行如下步骤： (1)将电池放入温度为 75℃±2℃ 的试验箱中保持 6h (2)将试验箱的温度降为 -40℃±2℃，并保持 6h (3)温度转换时间不大于 30min (4)重复步骤(1)~(3)，共循环 10 次

Note: Unless otherwise specified, all tests stated in this specification are conducted at the following conditions: Temp.: 20±5℃; Relative Humidity: 25%~85%.

备注：除特别说明外，本产品规格书规定的测试条件为：温度 20±5℃，相对湿度 25%~85%。

6. Battery Shipping Voltage 电池出货电压

Voltage: 3.2V~3.4V

电池出货电压：3.2V~3.4V

7. Warranty 保质期

6 months warranty for sample battery after date of production. One year warranty for finished battery after the date of production

样品电池保质期为（出厂之日起）半年；产品电池保质期为（出厂之日起）1 年。

Document Name	Document No.	Ver	Date	Page
LP904374F Specification	ZJQM-RD-SPC-A01523	0.0	2015-10-14	7/9

8. Matters Needing Attention 注意事项

Strictly observes the following needing attention. EEMB will not be responsible for any accident occurred by handling outside of the precautions in this specification.

您必须严格遵守下述电池使用注意事项。对于没有按照以下注意事项所造成的任何意外事故，EEMB 不承担任何责任。

! Danger 危险

- Strictly prohibits heat or throw cell into fire. 严禁把将电池投进火中或进行加热
- Strictly prohibits throw and wet cell in liquid such as water、gasoline or drink etc.
严禁把电池投入液体中，如水、汽油、饮料等，也不要弄湿。
- Strictly prohibits use leave cell close to fire or inside of a car where temperature may be above 60°C.
Also do not charge / discharge in such conditions.
禁止在火源附近或温度超过 60°C 的轿车中使用或遗留电池，也不要这些环境中进行充放电。
- Strictly prohibits put batteries in your pockets or a bag together with metal objects such as necklaces. Hairpins, coins, or screws. Do not store or transportation batteries with such objects.
禁止把电池同项链、发夹、硬币或螺钉等金属品一起放在兜中或包中，也不要把电池同上述物品一起储存或运输。
- Strictly prohibits short circuit the (+) and (-) terminals with other metals.
禁止使用金属导体短路电池的正负极。
- Do not place Cell in a device with the (+) and (-) in the wrong way around.
在装入设备时注意电池的正负极不要反装。
- Strictly prohibits pierce Cell with a sharp object such as a needle.
禁止使用锐利的物品刺穿电池。
- Strictly prohibits disassemble or modify the cell.
禁止对电池进行分解。
- Strictly prohibits welding a cell directly.
禁止直接对电池进行焊接。
- Do not use a Cell with serious scar or deformation.
禁止使用已经损坏的电池。
- Thoroughly read the user's manual before use, inaccurate handling of lithium iron phosphate rechargeable cell may cause leakage, heat, smoke, an explosion, or fire, capacity decreasing.
在使用之前请仔细阅读操作说明书，不适当的操作可能引起电池变热、着火、爆炸、毁坏或电池容量的衰减。

! Warning 警告

- Strictly prohibits put cell into a microware oven, dryer, or high-pressure container.
禁止把电池放加热器皿、洗衣机或高压容器中。
- Strictly prohibits use cell with dry cells and other primary batteries, or new and old battery or batteries of a different package, type, or brand.
禁止把电池同干电池或其它原电池或者新旧电池一起使用，也不要同不同包装、不同型号或不同品牌的电池一起使用。
- Stop charging the Cell if charging is not completed within the specified time.
如果在规定的充电时间内充电没有结束，停止充电。

Document Name	Document No.	Ver	Date	Page
LP904374F Specification	ZJQM-RD-SPC-A01523	0.0	2015-10-14	8/9

- Stop using the Cell if abnormal heat, odor, discoloration, deformation or abnormal condition is detected during use, charge, or storage.
在使用、充电或储存期间如发现电池有变热、散发气味、变色、变形或其它反常之处停止使用。
- Keep away from fire immediately when leakage or foul odor is detected.
当发现电池漏液或散发出难闻的气味时立即远离。
- If liquid leaks onto your skin or clothes, wash well with fresh water immediately.
如果电解液渗漏到您的皮肤或衣服上，立刻用大量清水冲洗。
- If liquid leaking from the Cell gets into your eyes, do not rub your eyes. Wash them well with clean edible oil and go to see a doctor immediately.
如果电解液渗出并进入您的眼睛里，不要揉擦您的眼睛，立刻用食用油清洗眼睛并就医。

! Caution 注 意

- Before using the Cell, be sure to read the user's manual and cautions on handling thoroughly.
在使用电池之前，应仔细阅读操作指南并对使用中的注意事项有足够深刻的理解。
- Charging with specific charger according to product specification. Charge with CC/CV method. Strictly prohibits reversed charging. Connect cell reverse will not charge the cell. At the same time, it will reduce the charge-discharge characteristics and safety characteristics; this will lead to product heat and leakage.
充电时请使用指定的充电器并按照本规格书的要求进行充电。采用恒流恒压方式充电，禁止反向充电。若电池正负极接反，将无法对电芯进行充电；同时，反向充电会降低电芯的充放电性能和安全性，并会导致发热和泄漏。
- Store batteries out of reach of children so that they are not accidentally swallowed.
把电池放到小孩够不到的地方以免吞服。
- If younger children use the Cell, their guardians should explain the proper handling.
小孩使用电池时，监护人应详细解释操作方法。
- Before using the Cell, be sure to read the user's manual and cautions on handling thoroughly.
在将电池装入设备或从设备中取出之前仔细阅读设备操作手册。
- Batteries have life cycles. If the time that the Cell powers equipment becomes much shorter than usual, the Cell life is at an end. Replace the Cell with a new same one.
电池具有使用寿命，如果使用电池的设备的工作时间比平常少的多，请更换新电池。
- When not using Cell for an extended period, remove it from the equipment and store in a place with low humidity and low temperature.
当长期不用时，要将电池从设备中取出并放在低温低湿的环境中保存。
- While the Cell pack is charged, used and stored, keep it away from objects or materials with static electric charges.
电池应在远离静电的场所进行充电、使用和储存。
- If the terminals of the Cell become dirty, wipe with a dry clothe before using the Cell.
如果电池的接线端变脏，在使用之前用干布擦净。
- Storage the cells in storage temperature range as the specifications. After full discharged, we suggest that charging to 3.2~3.4V. with no using for a long time.
电芯应贮存在产品规格书规定的温度范围内，电芯放电放完后，如果长期不使用，建议充电至 3.2~3.4V 贮存。
- Battery should be charged and discharged every 3 months at 0.2 C during long term storage, and then charge to 50-70% of the capacity for storage.
- 电池在长期贮存过程中，必须每 3 个月 0.2C 进行充放电一次，然后充电至 50~70% 的容量进行

Document Name	Document No.	Ver	Date	Page
LP904374F Specification	ZJQM-RD-SPC-A01523	0.0	2015-10-14	9/9

贮存。

- Do not exceed these ranges of the following temperature ranges:

电池在使用和贮存时的温度不能超出下面的要求:

Charge temperature range 充电 : 0°C to 45°C;

Discharge temperature range 放电 : -10°C to 60°C.

Store less than 1 month 贮存 1 个月 : -20°C - +60°C

Store less than 3 months 贮存 3 个月 : -20°C - +45°C

Store less than 1 year 贮存 12 个月 : -20°C - +25°C

! Special Notice 特别注意

Keep the cells in **50% charged state** during long period storage. We recommend to charge the battery up to 50% of the total capacity every 3 months after receipt of the battery and maintain the voltage 3.2~3.4V. And store the battery in cool and dry place.

电池在长时间储存的过程中保持带电量为 50%。我们建议每 3 个月充电至 **50%**以上容量, 保持电压在 3.2~3.4V。将电池存储在阴凉干燥的地方。

EEMB reserves the final explanation. Please use battery strictly according to specification. EEMB will not be responsible for any inappropriate operation. EEMB keeps the right to change product specifications without previous notice. If any question, please consult with the manufacturer

EEMB 保留最终解释权。请严格按照规范使用电池。EEMB 对任何不当操作将不负责。EEMB 保留修改产品规格书不另行通知的权利。如有任何问题, 请咨询制造商。