

## LPC660 Low Power CMOS Quad Operational Amplifier

### General Description

The LPC660 CMOS Quad operational amplifier is ideal for operation from a single supply. It features a wide range of operating voltages from +5V to +15V and features rail-to-rail output swing in addition to an input common-mode range that includes ground. Performance limitations that have plagued CMOS amplifiers in the past are not a problem with this design. Input  $V_{OS}$ , drift, and broadband noise as well as voltage gain (into 100 k $\Omega$  and 5 k $\Omega$ ) are all equal to or better than widely accepted bipolar equivalents, while the power supply requirement is typically less than 1 mW.

This chip is built with National's advanced Double-Poly Silicon-Gate CMOS process.

See the LPC662 datasheet for a Dual CMOS operational amplifier and LPC661 datasheet for a single CMOS operational amplifier with these same features.

- Long-term integrator
- High-impedance preamplifier
- Active filter
- Sample-and-Hold circuit
- Peak detector

### Features

- Rail-to-rail output swing
- Micropower operation: (1 mW)
- Specified for 100 k $\Omega$  and 5 k $\Omega$  loads
- High voltage gain: 120 dB
- Low input offset voltage: 3 mV
- Low offset voltage drift: 1.3  $\mu\text{V}/^\circ\text{C}$
- Ultra low input bias current: 2 fA
- Input common-mode includes  $V^-$
- Operation range from +5V to +15V
- Low distortion: 0.01% at 1 kHz
- Slew rate: 0.11 V/ $\mu\text{s}$
- Full military temp. range available

### Applications

- High-impedance buffer
- Precision current-to-voltage converter

### Connection Diagram

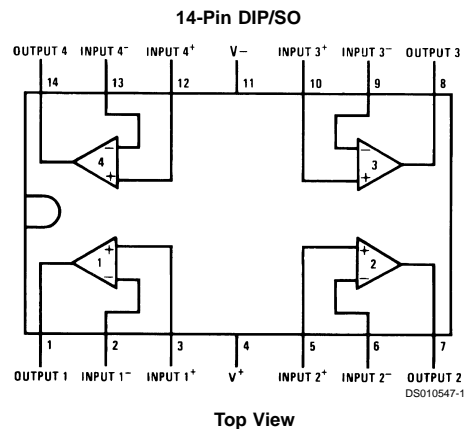

## Ordering Information

| Package                              | Temperature Range |                          | NSC<br>Drawing | Transport<br>Media    |
|--------------------------------------|-------------------|--------------------------|----------------|-----------------------|
|                                      | Military          | Industrial               |                |                       |
| 14-Pin<br>Side Brazed<br>Ceramic DIP | LPC660AMD         |                          | D14E           | Rail                  |
| 14-Pin<br>Small Outline              |                   | LPC660AIM<br>or LPC660IM | M14A           | Rail<br>Tape and Reel |
| 14-Pin<br>Molded DIP                 |                   | LPC660AIN<br>or LPC660IN | N14A           | Rail                  |
| 14-Pin<br>Ceramic DIP                | LPC660AMJ/883     |                          | J14A           | Rail                  |

## Absolute Maximum Ratings (Note 3)

If Military/Aerospace specified devices are required, please contact the National Semiconductor Sales Office/Distributors for availability and specifications.

|                                |                 |
|--------------------------------|-----------------|
| Differential Input Voltage     | ±Supply Voltage |
| Supply Voltage ( $V^+ - V^-$ ) | 16V             |
| Output Short Circuit to $V^+$  | (Note 11)       |
| Output Short Circuit to $V^-$  | (Note 1)        |
| Lead Temperature               |                 |
| (Soldering, 10 sec.)           | 260°C           |
| Storage Temp. Range            | -65°C to +150°C |
| Junction Temperature (Note 2)  | 150°C           |
| ESD Rating                     |                 |
| (C = 100 pF, R = 1.5 kΩ)       | 1000V           |
| Power Dissipation              | (Note 2)        |
| Current at Input Pin           | ±5 mA           |
| Current at Output Pin          | ±18 mA          |

|                             |                                    |
|-----------------------------|------------------------------------|
| Voltage at Input/Output Pin | ( $V^+$ ) + 0.3V, ( $V^-$ ) - 0.3V |
| Current at Power Supply Pin | 35 mA                              |

## Operating Ratings (Note 3)

|   |                        |
|---|------------------------|
| Temperature Range                               |                        |
| LPC660AM  | -55°C ≤ $T_J$ ≤ +125°C |
| LPC660AI  | -40°C ≤ $T_J$ ≤ +85°C  |
| LPC660I   | -40°C ≤ $T_J$ ≤ +85°C  |
| Supply Range                                    | 4.75V to 15.5V         |
| Power Dissipation                               | (Note 9)               |
| Thermal Resistance ( $\theta_{JA}$ ), (Note 10) |                        |
| 14-Pin Ceramic DIP                              | 90°C/W                 |
| 14-Pin Molded DIP                               | 85°C/W                 |
| 14-Pin SO                                       | 115°C/W                |
| 14-Pin Side Brazed Ceramic DIP                  | 90°C/W                 |

## DC Electrical Characteristics

Unless otherwise specified, all limits guaranteed for  $T_J = 25^\circ\text{C}$ . **Boldface** limits apply at the temperature extremes.  $V^+ = 5\text{V}$ ,  $V^- = 0\text{V}$ ,  $V_{CM} = 1.5\text{V}$ ,  $V_O = 2.5\text{V}$ , and  $R_L > 1\text{M}$  unless otherwise specified.

| Parameter                             | Conditions  | Typ         | LPC660AM                      | LPC660AI                      | LPC660I                       | Units                        |
|---------------------------------------|---|-------------|-------------------------------|-------------------------------|-------------------------------|------------------------------|
|                                       |   |             | LPC660AMJ/883                 | Limit                         | Limit                         |                              |
|                                       |   |             | (Notes 4, 8)                  | (Note 4)                      | (Note 4)                      |                              |
| Input Offset Voltage                  |   | 1           | 3                             | 3                             | 6                             | mV                           |
|                                       |   |             | <b>3.5</b>                    | <b>3.3</b>                    | <b>6.3</b>                    | max                          |
| Input Offset Voltage Average Drift    |   | 1.3         |                               |                               |                               | $\mu\text{V}/^\circ\text{C}$ |
| Input Bias Current                    |   | 0.002       | 20                            |                               |                               | pA                           |
|                                       |   |             | <b>100</b>                    | <b>4</b>                      | <b>4</b>                      | max                          |
| Input Offset Current                  |   | 0.001       | 20                            |                               |                               | pA                           |
|                                       |   |             | <b>100</b>                    | <b>2</b>                      | <b>2</b>                      | max                          |
| Input Resistance                      |   | >1          |                               |                               |                               | Tera $\Omega$                |
| Common Mode Rejection Ratio           | $0\text{V} \leq V_{CM} \leq 12.0\text{V}$<br>$V^+ = 15\text{V}$ | 83          | 70                            | 70                            | 63                            | dB                           |
| Positive Power Supply Rejection Ratio | $5\text{V} \leq V^+ \leq 15\text{V}$                            | 83          | 70                            | 70                            | 63                            | dB                           |
|                                       |   |             | <b>68</b>                     | <b>68</b>                     | <b>61</b>                     | min                          |
| Negative Power Supply Rejection Ratio | $0\text{V} \leq V^- \leq -10\text{V}$                           | 94          | 84                            | 84                            | 74                            | dB                           |
|                                       |   |             | <b>82</b>                     | <b>83</b>                     | <b>73</b>                     | min                          |
| Input Common Mode Voltage Range       | $V^+ = 5\text{V} \ \& \ 15\text{V}$<br>For CMRR > 50 dB         | -0.4        | -0.1                          | -0.1                          | -0.1                          | V                            |
|                                       |   |             | <b>0</b>                      | <b>0</b>                      | <b>0</b>                      | max                          |
|                                       |   | $V^+ - 1.9$ | $V^+ - 2.3$                   | $V^+ - 2.3$                   | $V^+ - 2.3$                   | V                            |
|                                       |   |             | <b><math>V^+ - 2.6</math></b> | <b><math>V^+ - 2.5</math></b> | <b><math>V^+ - 2.5</math></b> | min                          |
| Large Signal Voltage Gain             | $R_L = 100\text{ k}\Omega$ (Note 5)                             | 1000        | 400                           | 400                           | 300                           | V/mV                         |
|                                       |   |             | <b>250</b>                    | <b>300</b>                    | <b>200</b>                    | min                          |
|                                       |   | 500         | 180                           | 180                           | 90                            | V/mV                         |
|                                       | <b>70</b>   |             | <b>120</b>                    | <b>70</b>                     | min                           |                              |
|                                       | $R_L = 5\text{ k}\Omega$ (Note 5)                               | 1000        | 200                           | 200                           | 100                           | V/mV                         |
|                                       |   |             | <b>150</b>                    | <b>160</b>                    | <b>80</b>                     | min                          |
| 250                                   |   | 100         | 100                           | 50                            | V/mV                          |                              |
|                                       | <b>35</b>   | <b>60</b>   | <b>40</b>                     | min                           |                               |                              |

## DC Electrical Characteristics (Continued)

Unless otherwise specified, all limits guaranteed for  $T_J = 25^\circ\text{C}$ . **Boldface** limits apply at the temperature extremes.  $V^+ = 5\text{V}$ ,  $V^- = 0\text{V}$ ,  $V_{\text{CM}} = 1.5\text{V}$ ,  $V_{\text{O}} = 2.5\text{V}$ , and  $R_L > 1\text{M}$  unless otherwise specified.

| Parameter   | Conditions   | Typ   | LPC660AM  | LPC660AI          | LPC660I           | Units         |           |
|---|--|---|---|-------------------|-------------------|---------------|-----------|
|   |  |   | LPC660AMJ/883                                       | Limit             | Limit             |               | Limit     |
|   |  |   | Limit<br>(Notes 4, 8)                               | Limit<br>(Note 4) | Limit<br>(Note 4) |               |           |
| Output Swing  | $V^+ = 5\text{V}$<br>$R_L = 100\text{ k}\Omega$ to $V^+/2$ | 4.987   | 4.970   | 4.970             | 4.940             | V<br>min      |           |
|   |  |   | <b>4.950</b>  | <b>4.950</b>      | <b>4.910</b>      |               |           |
|   |  | 0.004   | 0.030   | 0.030             | 0.060             | V<br>max      |           |
|   |  |   | <b>0.050</b>  | <b>0.050</b>      | <b>0.090</b>      |               |           |
|   |  | 4.940   | 4.850   | 4.850             | 4.750             | V<br>min      |           |
|   |  |   | <b>4.750</b>  | <b>4.750</b>      | <b>4.650</b>      |               |           |
|   | $V^+ = 5\text{V}$<br>$R_L = 5\text{ k}\Omega$ to $V^+/2$   | 0.040   | 0.150   | 0.150             | 0.250             | V<br>max      |           |
|   |  |   | <b>0.250</b>  | <b>0.250</b>      | <b>0.350</b>      |               |           |
|   |  | $V^+ = 15\text{V}$<br>$R_L = 100\text{ k}\Omega$ to $V^+/2$ | 14.970  | 14.920            | 14.920            | 14.880        | V<br>min  |
|   |  |   |   | <b>14.880</b>     | <b>14.880</b>     | <b>14.820</b> |           |
|   |  |   | 0.007   | 0.030             | 0.030             | 0.060         | V<br>max  |
|   |  |   |   | <b>0.050</b>      | <b>0.050</b>      | <b>0.090</b>  |           |
| $V^+ = 15\text{V}$<br>$R_L = 5\text{ k}\Omega$ to $V^+/2$ | 14.840   |   | 14.680  | 14.680            | 14.580            | V<br>min      |           |
|   |  |   | <b>14.600</b>                                       | <b>14.600</b>     | <b>14.480</b>     |               |           |
|   | 0.110  | 0.220   | 0.220   | 0.320             | V<br>max          |               |           |
|   |  | <b>0.300</b>  | <b>0.300</b>  | <b>0.400</b>      |                   |               |           |
|   | Output Current<br>$V^+ = 5\text{V}$                        | Sourcing, $V_{\text{O}} = 0\text{V}$                        | 22  | 16                | 16                | 13            | mA<br>min |
|   |  |   |   | <b>12</b>         | <b>14</b>         | <b>11</b>     |           |
| Sinking, $V_{\text{O}} = 5\text{V}$                       |  |   | 21  | 16                | 16                | 13            | mA<br>min |
|   |  |   | <b>12</b>   | <b>14</b>         | <b>11</b>         |               |           |
|   |  | Output Current<br>$V^+ = 15\text{V}$                        | Sourcing, $V_{\text{O}} = 0\text{V}$                | 40                | 19                | 28            | 23        |
|   |  |   |   | <b>19</b>         | <b>25</b>         | <b>20</b>     |           |
| Sinking, $V_{\text{O}} = 13\text{V}$<br>(Note 11)         | 39   |   |   | 19                | 28                | 23            | mA<br>min |
|   |  |   | <b>19</b>   | <b>24</b>         | <b>19</b>         |               |           |
|   | Supply Current   |   | All Four Amplifiers<br>$V_{\text{O}} = 1.5\text{V}$ | 160               | 200               | 200           | 240       |
|   |  |   |   | <b>250</b>        | <b>230</b>        | <b>270</b>    |           |

## AC Electrical Characteristics

Unless otherwise specified, all limits guaranteed for  $T_J = 25^\circ\text{C}$ . **Boldface** limits apply at the temperature extremes.  $V^+ = 5\text{V}$ ,  $V^- = 0\text{V}$ ,  $V_{\text{CM}} = 1.5\text{V}$ ,  $V_{\text{O}} = 2.5$ , and  $R_L > 1\text{M}$  unless otherwise specified.

| Parameter                    | Conditions   | Typ    | LPC660AM              | LPC660AI          | LPC660I           | Units                   |
|------------------------------|--|--------|-----------------------|-------------------|-------------------|-------------------------|
|                              |  |        | LPC660AMJ/883         | Limit             | Limit             |                         |
|                              |  |        | Limit<br>(Notes 4, 8) | Limit<br>(Note 4) | Limit<br>(Note 4) |                         |
| Slew Rate                    | (Note 6)   | 0.11   | 0.07                  | 0.07              | 0.05              | V/ $\mu\text{s}$<br>min |
|                              |  |        | <b>0.04</b>           | <b>0.05</b>       | <b>0.03</b>       |                         |
| Gain-Bandwidth Product       |  | 0.35   |                       |                   |                   | MHz                     |
| Phase Margin                 |  | 50     |                       |                   |                   | Deg                     |
| Gain Margin                  |  | 17     |                       |                   |                   | dB                      |
| Amp-to-Amp Isolation         | (Note 7)   | 130    |                       |                   |                   | dB                      |
| Input Referred Voltage Noise | F = 1 kHz  | 42     |                       |                   |                   | nV/ $\sqrt{\text{Hz}}$  |
| Input Referred Current Noise | F = 1 kHz  | 0.0002 |                       |                   |                   | pA/ $\sqrt{\text{Hz}}$  |
| Total Harmonic Distortion    | F = 1 kHz, $A_v = -10$<br>$R_L = 100\text{ k}\Omega$ , $V_{\text{O}} = 8\text{ V}_{\text{PP}}$ | 0.01   |                       |                   |                   | %                       |

**Note 1:** Applies to both single supply and split supply operation. Continuous short circuit operation at elevated ambient temperature and/or multiple Op Amp shorts can result in exceeding the maximum allowed junction temperature of  $150^\circ\text{C}$ . Output currents in excess of  $\pm 30\text{ mA}$  over long term may adversely affect reliability.

**Note 2:** The maximum power dissipation is a function of  $T_{\text{J(max)}}$ ,  $\theta_{\text{JA}}$  and  $T_{\text{A}}$ . The maximum allowable power dissipation at any ambient temperature is  $P_{\text{D}} = (T_{\text{J(max)}} - T_{\text{A}})/\theta_{\text{JA}}$ .

**Note 3:** Absolute Maximum Ratings indicate limits beyond which damage to the device may occur. Operating Ratings indicate conditions for which the device is intended to be functional, but do not guarantee specific performance limits. For guaranteed specifications and test conditions, see the Electrical Characteristics. The guaranteed specifications apply only for the test conditions listed.

**Note 4:** Limits are guaranteed by testing or correlation.

**Note 5:**  $V^+ = 15\text{V}$ ,  $V_{\text{CM}} = 7.5\text{V}$  and  $R_L$  connected to  $7.5\text{V}$ . For Sourcing tests,  $7.5\text{V} \leq V_{\text{O}} \leq 11.5\text{V}$ . For Sinking tests,  $2.5\text{V} \leq V_{\text{O}} \leq 7.5\text{V}$ .

**Note 6:**  $V^+ = 15\text{V}$ . Connected as Voltage Follower with  $10\text{V}$  step input. Number specified is the slower of the positive and negative slew rates.

**Note 7:** Input referred.  $V^+ = 15\text{V}$  and  $R_L = 100\text{ k}\Omega$  connected to  $V^+/2$ . Each amp excited in turn with  $1\text{ kHz}$  to produce  $V_{\text{O}} = 13\text{ V}_{\text{PP}}$ .

**Note 8:** A military RETS electrical test specification is available on request. At the time of printing, the LPC660AMJ/883 RETS specification complied fully with the **boldface** limits in this column. The LPC660AMJ/883 may also be procured to a Standard Military Drawing specification.

**Note 9:** For operating at elevated temperatures, the device must be derated based on the thermal resistance  $\theta_{\text{JA}}$  with  $P_{\text{D}} = (T_{\text{J}} - T_{\text{A}})/\theta_{\text{JA}}$ .

**Note 10:** All numbers apply for packages soldered directly into a PC board.

**Note 11:** Do not connect output to  $V^+$  when  $V^+$  is greater than  $13\text{V}$  or reliability may be adversely affected.

## Typical Performance Characteristics $V_{\text{S}} = \pm 7.5\text{V}$ , $T_{\text{A}} = 25^\circ\text{C}$ unless otherwise specified

Supply Current vs Supply Voltage

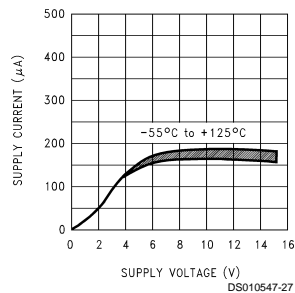

Input Bias Current vs Temperature

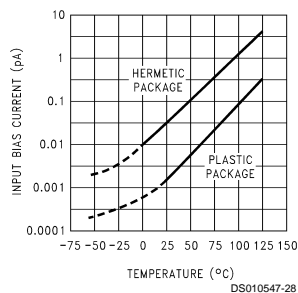

Common-Mode Voltage Range vs Temperature

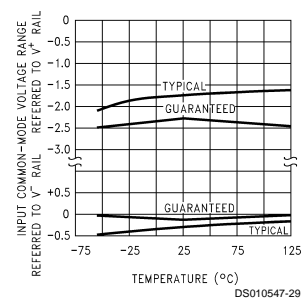

**Typical Performance Characteristics**  $V_S = \pm 7.5V$ ,  $T_A = 25^\circ C$  unless otherwise specified (Continued)

**Output Characteristics  
Current Sinking**

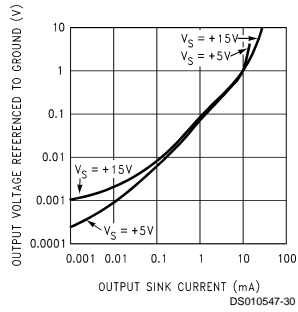

**Output Characteristics  
Current Sourcing**

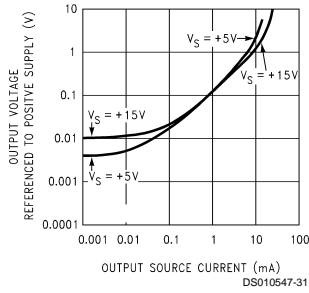

**Input Voltage Noise  
vs Frequency**

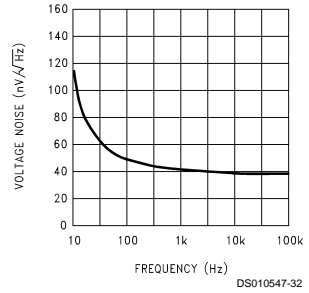

**Crosstalk Rejection  
vs Frequency**

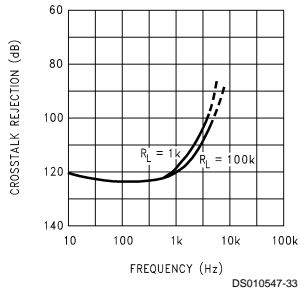

**CMRR vs Frequency**

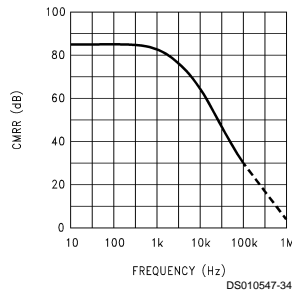

**CMRR vs Temperature**

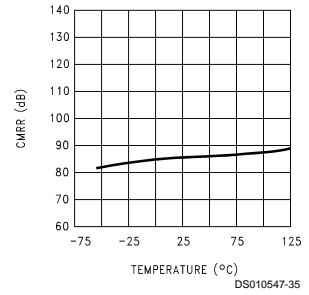

**Power Supply Rejection  
Ratio vs Frequency**

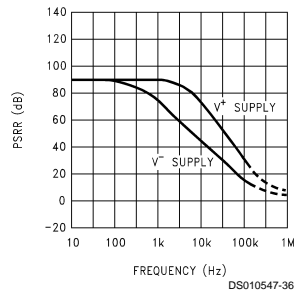

**Typical Performance Characteristics**  $V_S = \pm 7.5V$ ,  $T_A = 25^\circ C$  unless otherwise specified (Continued)

**Open-Loop Voltage Gain vs Temperature**

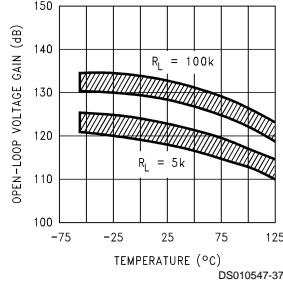

**Open-Loop Frequency Response**

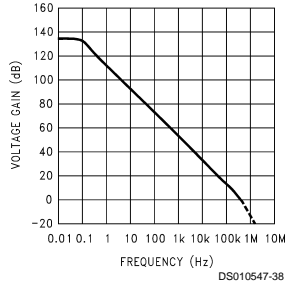

**Gain and Phase Responses vs Load Capacitance**

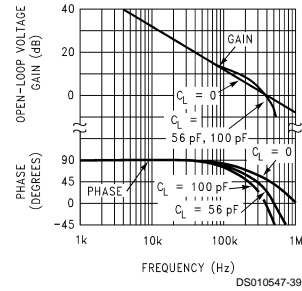

**Gain and Phase Responses vs Temperature**

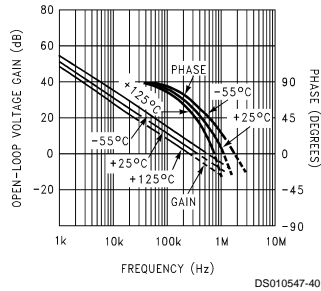

**Gain Error ( $V_{OS}$  vs  $V_{OUT}$ )**

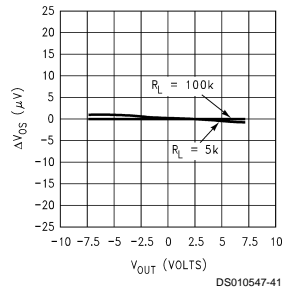

**Non-Inverting Slew Rate vs Temperature**

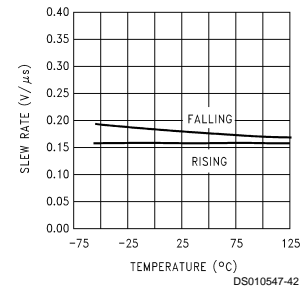

**Inverting Slew Rate vs Temperature**

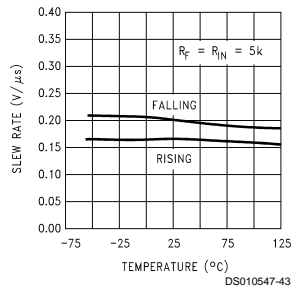

**Large-Signal Pulse Non-Inverting Response ( $A_V = +1$ )**

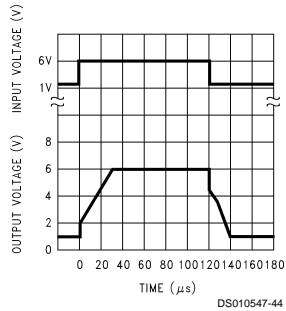

**Non-Inverting Small Signal Pulse Response ( $A_V = +1$ )**

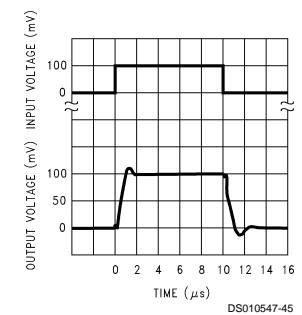

**Typical Performance Characteristics**  $V_S = \pm 7.5V$ ,  $T_A = 25^\circ C$  unless otherwise specified (Continued)

**Inverting Large-Signal Pulse Response**

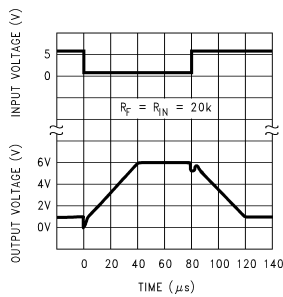

DS010547-46

**Inverting Small-Signal Pulse Response**

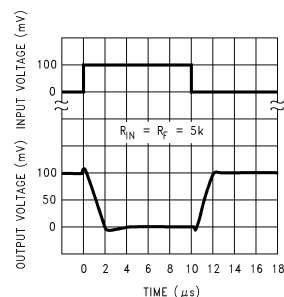

DS010547-47

**Stability vs Capacitive Load**

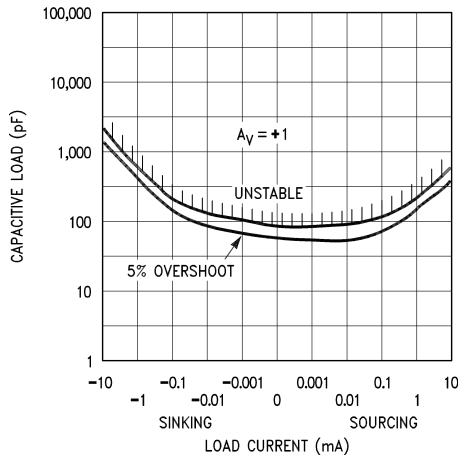

DS010547-4

**Note:** Avoid resistive loads of less than 500Ω, as they may cause instability.

**Stability vs Capacitive Load**

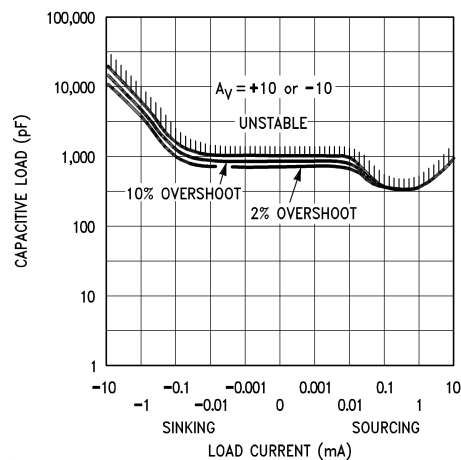

DS010547-5

**Application Hints**

**AMPLIFIER TOPOLOGY**

The topology chosen for the LPC660 is unconventional (compared to general-purpose op amps) in that the traditional unity-gain buffer output stage is not used; instead, the output is taken directly from the output of the integrator, to allow rail-to-rail output swing. Since the buffer traditionally delivers the power to the load, while maintaining high op amp gain and stability, and must withstand shorts to either rail, these tasks now fall to the integrator.

As a result of these demands, the integrator is a compound affair with an embedded gain stage that is doubly fed forward (via  $C_f$  and  $C_{ff}$ ) by a dedicated unity-gain compensation driver. In addition, the output portion of the integrator is a push-pull configuration for delivering heavy loads. While sinking current the whole amplifier path consists of three gain stages with one stage fed forward, whereas while sourcing the path contains four gain stages with two fed forward.

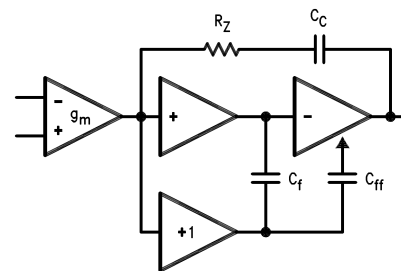

DS010547-6

**FIGURE 1. LPC660 Circuit Topology (Each Amplifier)**

The large signal voltage gain while sourcing is comparable to traditional bipolar op amps, for load resistance of at least 5 kΩ. The gain while sinking is higher than most CMOS op



## Application Hints (Continued)

amps, due to the additional gain stage; however, when driving load resistance of 5 k $\Omega$  or less, the gain will be reduced as indicated in the Electrical Characteristics. The op amp can drive load resistance as low as 500 $\Omega$  without instability.

### COMPENSATING INPUT CAPACITANCE

Refer to the LMC660 or LMC662 datasheets to determine whether or not a feedback capacitor will be necessary for compensation and what the value of that capacitor would be.

### CAPACITIVE LOAD TOLERANCE

Like many other op amps, the LPC660 may oscillate when its applied load appears capacitive. The threshold of oscillation varies both with load and circuit gain. The configuration most sensitive to oscillation is a unity-gain follower. See the Typical Performance Characteristics.

The load capacitance interacts with the op amp's output resistance to create an additional pole. If this pole frequency is sufficiently low, it will degrade the op amp's phase margin so that the amplifier is no longer stable at low gains. The addition of a small resistor (50 $\Omega$  to 100 $\Omega$ ) in series with the op amp's output, and a capacitor (5 pF to 10 pF) from inverting input to output pins, returns the phase margin to a safe value without interfering with lower-frequency circuit operation. Thus, larger values of capacitance can be tolerated without oscillation. Note that in all cases, the output will ring heavily when the load capacitance is near the threshold for oscillation.

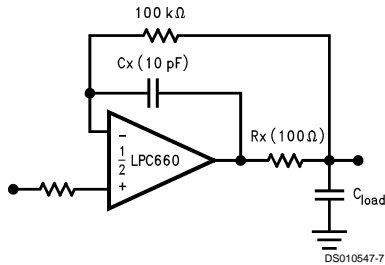

**FIGURE 2. Rx, Cx Improve Capacitive Load Tolerance**

Capacitive load driving capability is enhanced by using a pull up resistor to V<sup>+</sup> (Figure 3). Typically a pull up resistor conducting 50  $\mu$ A or more will significantly improve capacitive load responses. The value of the pull up resistor must be determined based on the current sinking capability of the ampli-

fier with respect to the desired output swing. Open loop gain of the amplifier can also be affected by the pull up resistor (see Electrical Characteristics).

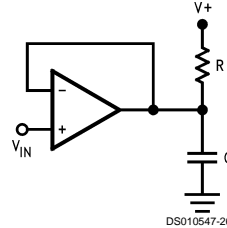

**FIGURE 3. Compensating for Large Capacitive Loads with A Pull Up Resistor**

### PRINTED-CIRCUIT-BOARD LAYOUT FOR HIGH-IMPEDANCE WORK

It is generally recognized that any circuit which must operate with less than 1000 pA of leakage current requires special layout of the PC board. When one wishes to take advantage of the ultra-low bias current of the LPC660, typically less than 0.04 pA, it is essential to have an excellent layout. Fortunately, the techniques for obtaining low leakages are quite simple. First, the user must not ignore the surface leakage of the PC board, even though it may sometimes appear acceptably low, because under conditions of high humidity or dust or contamination, the surface leakage will be appreciable.

To minimize the effect of any surface leakage, lay out a ring of foil completely surrounding the LPC660's inputs and the terminals of capacitors, diodes, conductors, resistors, relay terminals, etc. connected to the op-amp's inputs. See Figure 4. To have a significant effect, guard rings should be placed on both the top and bottom of the PC board. This PC foil must then be connected to a voltage which is at the same voltage as the amplifier inputs, since no leakage current can flow between two points at the same potential. For example, a PC board trace-to-pad resistance of 10<sup>12</sup> ohms, which is normally considered a very large resistance, could leak 5 pA if the trace were a 5V bus adjacent to the pad of an input. This would cause a 100 times degradation from the LPC660's actual performance. However, if a guard ring is held within 5 mV of the inputs, then even a resistance of 10<sup>11</sup> ohms would cause only 0.05 pA of leakage current, or perhaps a minor (2:1) degradation of the amplifier's performance. See Figure 5a, Figure 5b, Figure 5d for typical connections of guard rings for standard op-amp configurations. If both inputs are active and at high impedance, the guard can be tied to ground and still provide some protection; see Figure 5d.

## Application Hints (Continued)

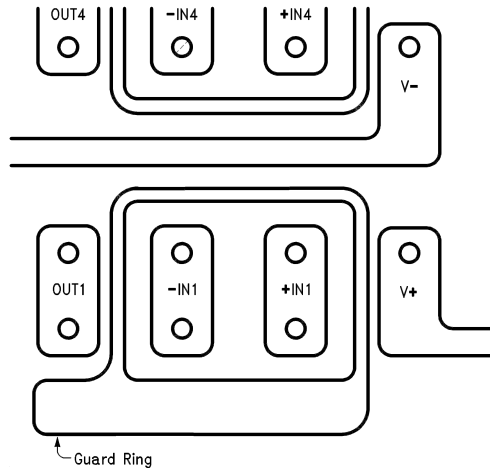

DS010547-19

FIGURE 4. Example of Guard Ring in P.C. Board Layout using the LPC660

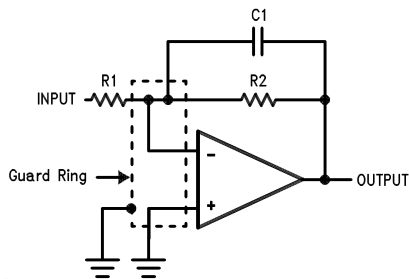

DS010547-20

(a) Inverting Amplifier

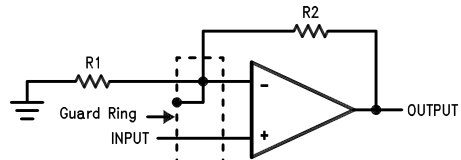

DS010547-21

(b) Non-Inverting Amplifier

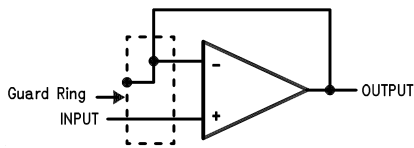

DS010547-22

(c) Follower

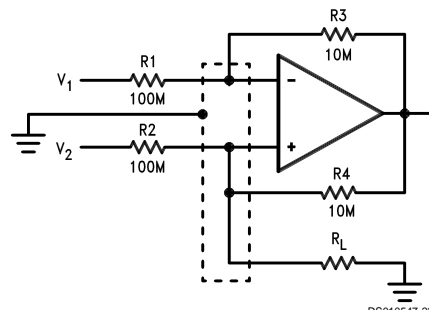

DS010547-23

(d) Howland Current Pump

FIGURE 5. Guard Ring Connections

The designer should be aware that when it is inappropriate to lay out a PC board for the sake of just a few circuits, there is another technique which is even better than a guard ring on a PC board: Don't insert the amplifier's input pin into the board at all, but bend it up in the air and use only air as an insulator. Air is an excellent insulator. In this case you may have to forego some of the advantages of PC board con-

struction, but the advantages are sometimes well worth the effort of using point-to-point up-in-the-air wiring. See Figure 6.

## Application Hints (Continued)

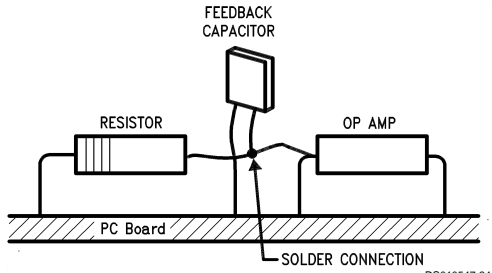

(Input pins are lifted out of PC board and soldered directly to components. All other pins connected to PC board.)

FIGURE 6. Air Wiring

### BIAS CURRENT TESTING

The test method of *Figure 7* is appropriate for bench-testing bias current with reasonable accuracy. To understand its operation, first close switch S2 momentarily. When S2 is opened, then

$$I^- = \frac{dV_{OUT}}{dt} \times C_2$$

## Typical Single-Supply Applications $(V^+ = 5.0 V_{DC})$

### Photodiode Current-to-Voltage Converter

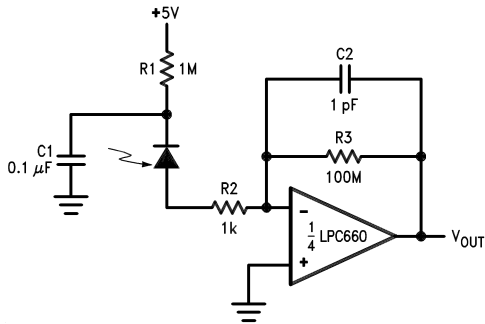

DS010547-17

**Note:** A 5V bias on the photodiode can cut its capacitance by a factor of 2 or 3, leading to improved response and lower noise. However, this bias on the photodiode will cause photodiode leakage (also known as its dark current).

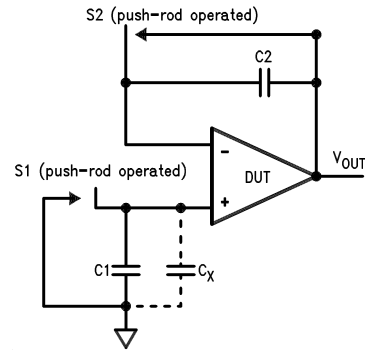

DS010547-25

FIGURE 7. Simple Input Bias Current Test Circuit

A suitable capacitor for C2 would be a 5 pF or 10 pF silver mica, NPO ceramic, or air-dielectric. When determining the magnitude of  $I^-$ , the leakage of the capacitor and socket must be taken into account. Switch S2 should be left shorted most of the time, or else the dielectric absorption of the capacitor C2 could cause errors.

Similarly, if S1 is shorted momentarily (while leaving S2 shorted)

$$I^+ = \frac{dV_{OUT}}{dt} \times (C_1 + C_x)$$

where  $C_x$  is the stray capacitance at the + input.

### Micropower Current Source

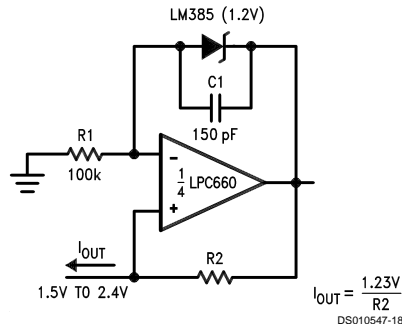

$$I_{OUT} = \frac{1.23V}{R_2}$$

DS010547-18

**Note:** (Upper limit of output range dictated by input common-mode range; lower limit dictated by minimum current requirement of LM385.)

## Typical Single-Supply Applications (V<sup>+</sup> = 5.0 V<sub>DC</sub>) (Continued)

### Low-Leakage Sample-and-Hold

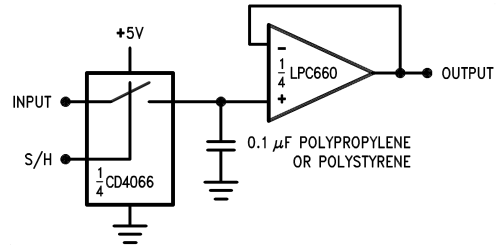

### Instrumentation Amplifier

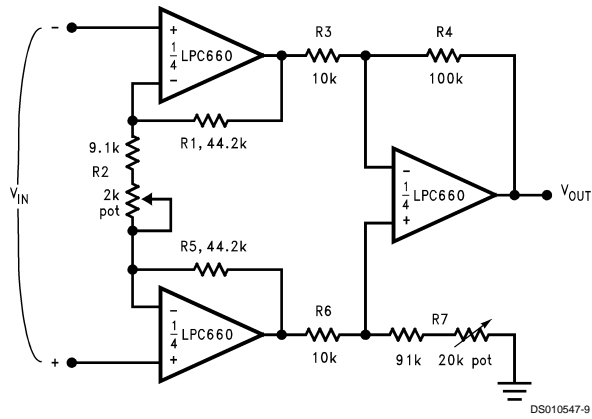

If  $R1 = R5$ ,  $R3 = R6$ , and  $R4 = R7$ :

$$\text{then } \frac{V_{OUT}}{V_{IN}} = \frac{R2 + 2R1}{R1} \times \frac{R4}{R3}$$

$\therefore A_V \approx 100$  for circuits shown.

For good CMRR over temperature, low drift resistors should be used. Matching of  $R3$  to  $R6$  and  $R4$  to  $R7$  affects CMRR. Gain may be adjusted through  $R2$ . CMRR may be adjusted through  $R7$ .

## Typical Single-Supply Applications (V<sup>+</sup> = 5.0 V<sub>DC</sub>) (Continued)

### Sine-Wave Oscillator

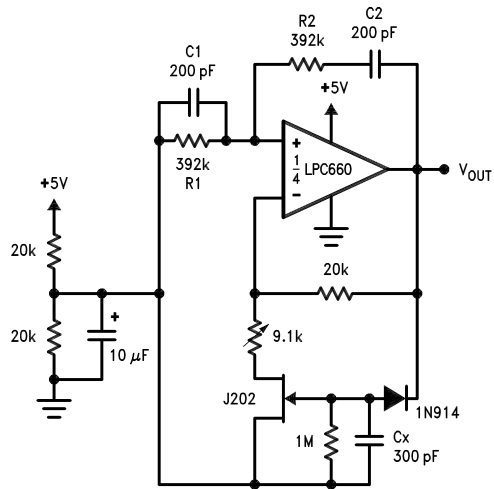

DS010547-10

Oscillator frequency is determined by R1, R2, C1, and C2:

$$f_{\text{OSC}} = 1/2\pi RC$$

where R = R1 = R2 and C = C1 = C2.

This circuit, as shown, oscillates at 2.0 kHz with a peak-to-peak output swing of 4.5V

### 1 Hz Square-Wave Oscillator

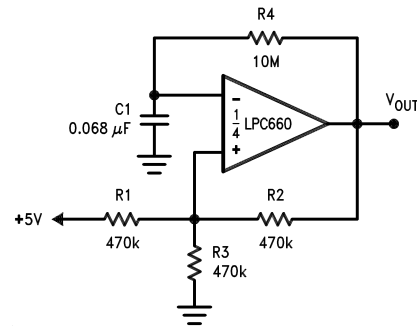

DS010547-11

### Power Amplifier

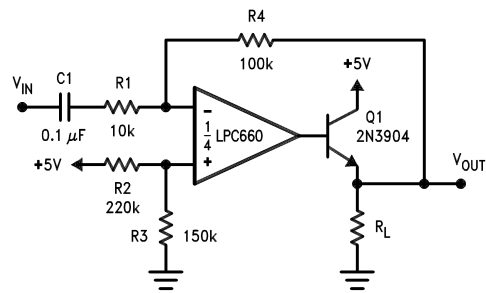

DS010547-12

## Typical Single-Supply Applications ( $V^+ = 5.0 V_{DC}$ ) (Continued)

### 10 Hz Bandpass Filter

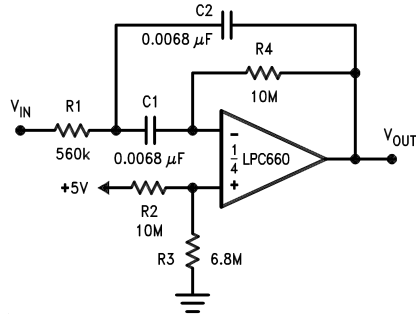

DS010547-13

$f_o = 10 \text{ Hz}$   
 $Q = 2.1$   
 Gain = -8.8

### 10 Hz High-Pass Filter (2 dB Dip)

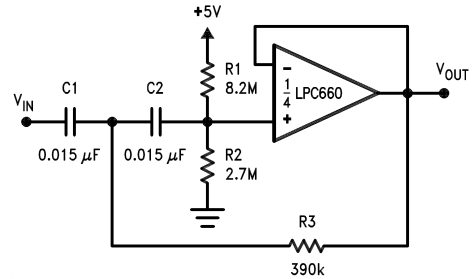

DS010547-14

$f_c = 10 \text{ Hz}$   
 $d = 0.895$   
 Gain = 1

### 1 Hz Low-Pass Filter (Maximally Flat, Dual Supply Only)

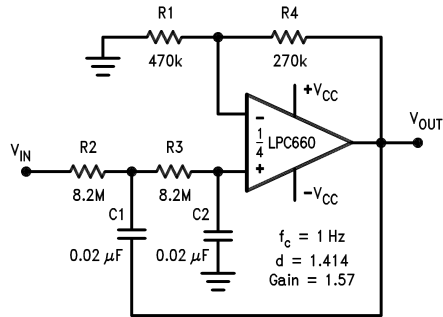

DS010547-15

$f_c = 1 \text{ Hz}$   
 $d = 1.414$   
 Gain = 1.57

### High Gain Amplifier with Offset Voltage Reduction

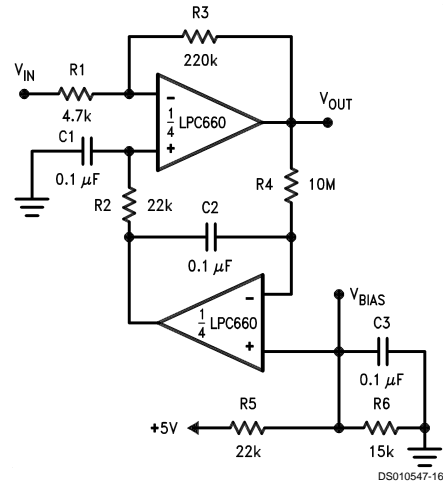

DS010547-16

Gain = -46.8  
 Output offset voltage reduced to the level of the input offset voltage of the bottom amplifier (typically 1 mV), referred to  $V_{BIAS}$ .

**Physical Dimensions** inches (millimeters) unless otherwise noted

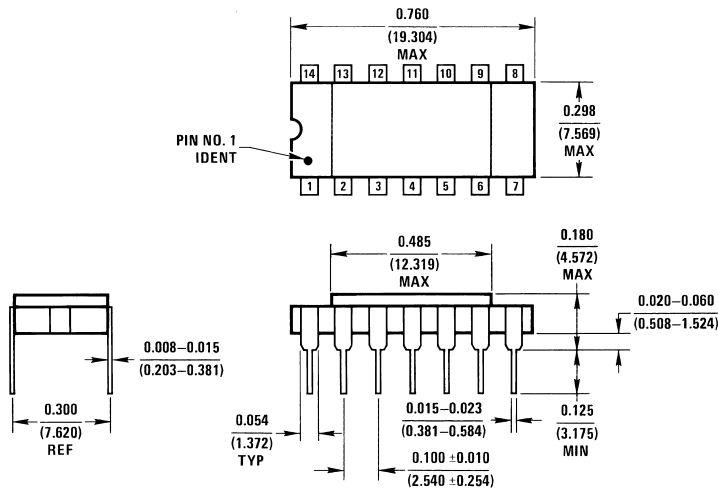

D14E (REV E)

**14-Pin Cavity Dual-In-Line Package (D)**  
**Order Number LPC660AMD**  
**NS Package Number D14E**

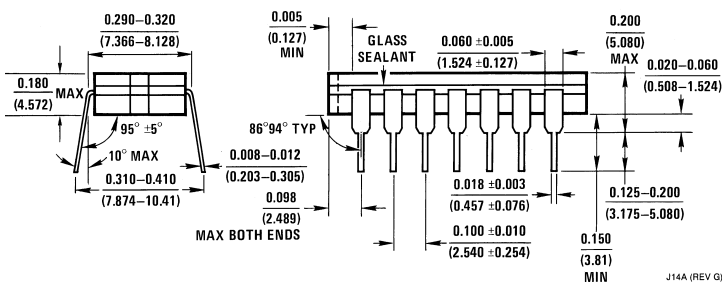
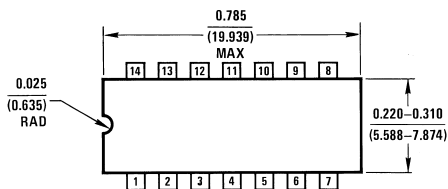

J14A (REV G)

**14-Lead Ceramic Dual-In-Line Package (J)**  
**Order Number LPC660AMJ/883**  
**NS Package Number J14A**

**Physical Dimensions** inches (millimeters) unless otherwise noted (Continued)

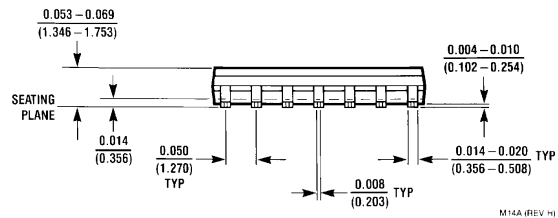
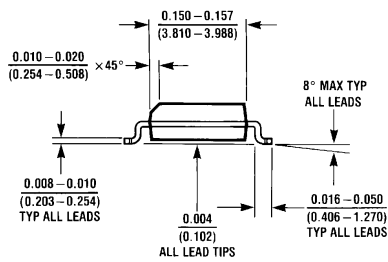
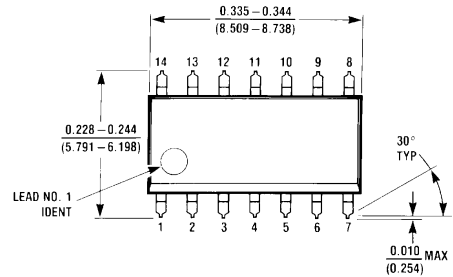

M14A (REV H)

**14-Pin Small Outline Molded Package (M)**  
**Order Number LPC660AIM or LPC660IM**  
**NS Package Number M14A**

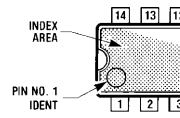
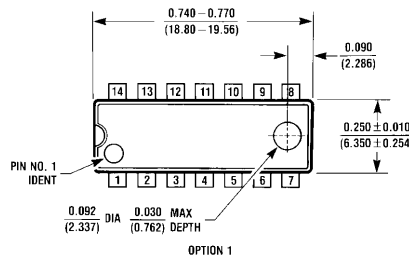

OPTION 02

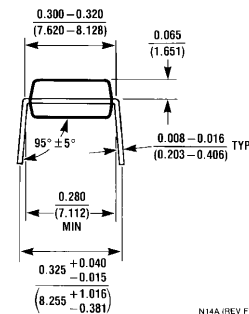
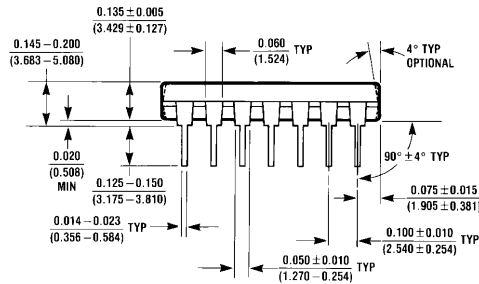

N14A (REV F)

**14-Pin Molded Dual-In-Line Package (N)**  
**Order Number LPC660AIN or LPC660IN**  
**NS Package Number N14A**



## Notes

### LIFE SUPPORT POLICY

NATIONAL'S PRODUCTS ARE NOT AUTHORIZED FOR USE AS CRITICAL COMPONENTS IN LIFE SUPPORT DEVICES OR SYSTEMS WITHOUT THE EXPRESS WRITTEN APPROVAL OF THE PRESIDENT OF NATIONAL SEMICONDUCTOR CORPORATION. As used herein:

1. Life support devices or systems are devices or systems which, (a) are intended for surgical implant into the body, or (b) support or sustain life, and whose failure to perform when properly used in accordance with instructions for use provided in the labeling, can be reasonably expected to result in a significant injury to the user.
2. A critical component is any component of a life support device or system whose failure to perform can be reasonably expected to cause the failure of the life support device or system, or to affect its safety or effectiveness.



**National Semiconductor Corporation**  
Americas  
Tel: 1-800-272-9959  
Fax: 1-800-737-7018  
Email: support@nsc.com

[www.national.com](http://www.national.com)

**National Semiconductor Europe**  
Fax: +49 (0) 1 80-530 85 86  
Email: europe.support@nsc.com  
Deutsch Tel: +49 (0) 1 80-530 85 85  
English Tel: +49 (0) 1 80-532 78 32  
Français Tel: +49 (0) 1 80-532 93 58  
Italiano Tel: +49 (0) 1 80-534 16 80

**National Semiconductor Asia Pacific Customer Response Group**  
Tel: 65-2544466  
Fax: 65-2504466  
Email: sea.support@nsc.com

**National Semiconductor Japan Ltd.**  
Tel: 81-3-5639-7560  
Fax: 81-3-5639-7507