

PREPARED BY: _____	DATE _____	 DISPLAY DEVICE GROUP SHARP(CHINA) INVESTMENT CO.,LTD <b>SPECIFICATION</b>	SPEC No. LCY-W12203C
			FILE No.
APPROVED BY: _____	DATE _____		ISSUE: Apr. 19. 2013
			PAGE : 44 pages

DEVICE SPECIFICATION FOR  
**TFT-LCD module**  
 MODEL No. LQ040Y3DX80



CUSTOMER'S APPROVAL

DATE \_\_\_\_\_  
 BY \_\_\_\_\_

DATE \_\_\_\_\_  
 BY \_\_\_\_\_

PRESENTED  
 BY T. Yamamoto

TAKAHIRO YAMAMOTO  
 DEPARTMENT GENERAL MANAGER  
 DEVELOPMENT DIVISION II  
 DESIGN CENTER 2  
 DISPLAY DEVICE GROUP  
 SHARP(CHINA) INVESTMENT CO.,LTD



## TFT-LCD MODULE

## LQ040Y3DX80

## DEVICE SPECIFICATIONS

## CONTENTS

1	General	P3
2	Features	P3
3	Mechanical specifications	P3
4	Input terminal and its function	P4
5	Absolute maximum ratings	P5
6	Electrical characteristics(DC Characteristics)	P6
7	Electrical characteristics (AC Characteristics/Functional Description)	P7
8	Power On/Off Sequence	P14
9	Reset input timing	P14
10	Initial Sequence	P15
11	Internal Display Backlight Control (PWM Control, CABC)	P18
12	Serial Interface	P19
13	Optical characteristics	P21
14	Display quality	P23
15	Mechanical characteristics	P23
16	For handling and system design	P23
17	Packaging Specification	P24
18	For operating LCD module	P25
19	Precautions for Storage	P25
20	Serial Number Label Identification	P26
21	Reliability Test Items	P26
22	RoHS	P27
Fig 1	Outline dimensions	P28
Appendix	Initial Code	P29

## NOTICE

\* "SHARP" includes the meaning of Wuxi Sharp Electronic Components Co., Ltd.

This publication is the proprietary of SHARP and is copyrighted, with all rights reserved. Under the copyright laws, no part of this publication may be reproduced or transmitted in any form or by any means, electronic or mechanical for any purpose, in whole or in part, without the express written permission of SHARP. Express written permission is also required before any use of this publication may be made by a third party.

The application circuit examples in this publication are provided to explain the representative applications of SHARP devices and are not intended to guarantee any circuit design or permit any industrial property right or other rights to be executed. SHARP takes no responsibility for any problems related to any industrial property right or a third party resulting from the use of SHARP devices, except for those resulting directly from device manufacturing processes.

In the absence of confirmation by device specification sheets, SHARP takes no responsibility for any defects that occur in equipment using any of SHARP devices, shown in catalogs, data books, etc. Contact to WUXI SHARP in order to obtain the latest device specification sheets before using any WUXI SHARP devices.

SHARP reserves the right to make changes in the specifications, characteristics, data, materials, structures and other contents described herein at any time without notice in order to improve design or reliability. Contact to WUXI SHARP in order to obtain the latest specification sheets before using any WUXI SHARP devices. Manufacturing locations are also subject to change without notice.

Observe the following points when using any device in this publication. SHARP takes no responsibility for damage caused by improper use of the devices.

This device was developed for the China domestic market.

This device may make change of material in the range of specification sheet description for performance improvement etc.. Please understand in advance it. In that case we will contact you in advance.

The devices in this publication are designed for use in general electronic equipment designs , such as:

Consumer electronics / Personal computers / Office automation equipment / Telecommunication equipment / PDA(Personal digital assistant) / MID(Multimedia information display) / Audio visual equipment /

The appropriate design measures should be taken to ensure reliability and safety when SHARP's devices are used for equipment, such as:

- Transportation control and safety equipment(i.e., aircraft ,trains, automobiles etc.)
- Traffic signals · Gas leakage sensor breakers · Alarm equipment · Various safety devices etc.

SHARP's devices shall not be used for equipment that requires extremely high level of reliability, such as:

- Military and space applications · Nuclear power control equipment · Medical equipment for life support

Contact to WUXI SHARP representative, in advance, when intending to use WUXI SHARP's devices for any "specific" applications other than those recommended by WUXI SHARP.

Contact and consult with a WUXI SHARP representative if there are any questions about the contents of this publication.

## 1. General

This TFT-LCD module is a color active matrix LCD (Liquid Crystal Display) module of transmissive type incorporating amorphous silicon TFT (Thin Film Transistor). General specification of the module is shown in the Table 3-1. It is composed of a color TFT-LCD panel, driver IC, FPC, backlight unit.

This TFT-LCD module is controlled by LCD driver IC NT35512. LCD driver IC basic specification refer to the LCD driver IC specification sheet.



## 2. Features

- Utilizes a panel with a 3:5 aspect ratio, which makes the module suitable for use in wide screen systems.
- The 3.97 screen produces a high resolution image that is composed of 384,000 pixels elements in a stripe arrangement.
- Graphics and texts can be displayed on a 480 x RGB x 800 dots panel with 16,777,216 colors by supplying 24 bits (8 bits×RGB) data signal.
- Wide viewing field angle technology is employed.
- By adopting an active matrix drive, a picture with high contrast is realized.
- By COG method, realized a slim, lightweight, and compact module.
- Realized a high quality picture of the natural color appearance by adopting Normally Black Mode which is superior to the color appearance.
- 24bit RGB interface. 

## 3. Mechanical specifications

Table 3-1

Parameter	Specifications	Units	Remarks
Display format	480×RGB×800	pixels	
Active area	51.84 (W)×86.4(H)	mm	
Screen size (Diagonal)	3.97	inch	
Dot pitch	0.108(H) X 0.108(V)	mm	
Display mode	Transmissive , Normally black	-	
Pixel configuration	R. G. B. vertical stripe	-	
Viewing angle	Full viewing	-	
Outline dimensions(typ)	57.14(W)×96.85(H)×1.85(D)	mm	[Note3-1]
Mass	21.3 (MAX)	g	

[Note3-1] Typical values are shown.

For detailed measurements and tolerances, please refer to Fig.1.  
(FPC, electronic parts are excepted.)

**4. Input terminal and its function**

## 4-1 TFT-LCD panel driving part

Table 4-1

Recommended connector : FH26-51S-0.3SHW





Pin No.	Symbol	I/O	Description	Remarks
1	LEDK	-	LED backlight cathode(-)	
2	LEDA	-	LED backlight anode(+)	
3	YU(NC)	-	No connection	
4	XR(NC)	-	No connection	
5	YD(NC)	-	No connection	
6	XL(NC)	-	No connection	
7	GND	-	Power ground	
8	VCI	-	Power supply to liquid crystal power supply(analog)	
9	NC	-	Open	
10	IOVCC	-	Power supply to interface pins(logic)	
11	TE	O	FMARK Signal	
12	SDO	O	Serial data output pin	
13	SDI	I/O	Serial data input bus.	
14	SCL	I	Serial clock pin 	
15	CS	I	Chip select input pin ("Low" enable)	
16	RESET	I	Reset the device. Signal is low active	
17	DB23	I/O	Data Bus	
18	DB22	I/O	Data Bus	
19	DB21	I/O	Data Bus	
20	DB20	I/O	Data Bus	
21	DB19	I/O	Data Bus	
22	DB18	I/O	Data Bus	
23	DB17	I/O	Data Bus	
24	DB16	I/O	Data Bus	
25	DB15	I/O	Data Bus	
26	DB14	I/O	Data Bus	
27	DB13	I/O	Data Bus	
28	DB12	I/O	Data Bus	
29	DB11	I/O	Data Bus	
30	DB10	I/O	Data Bus	
31	DB09	I/O	Data Bus	
32	DB08	I/O	Data Bus	
33	DB07	I/O	Data Bus	
34	DB06	I/O	Data Bus	
35	DB05	I/O	Data Bus	
36	DB04	I/O	Data Bus	
37	DB03	I/O	Data Bus	
38	DB02	I/O	Data Bus	
39	DB01	I/O	Data Bus	
40	DB00	I/O	Data Bus	
41	ENABLE	I	Data Enable signal	
42	DOTCLK	I	Pixel clock signal	
43	HSYNC	I	Horizontal Sync signal	
44	VSYNC	I	Vertical Sync signal	
45	LEDPWM	O	It is a PWM type control signal for brightness of the LED backlight.	
46	LEDON	O	It is a LED driver control signal which is used for turning ON/OFF the LED backlight.	

Table 4-1 (sequel)

Pin No.	Symbol	I/O	Description	Remarks
47	NC 	I	Open	
48	NC 	I	Open	
49	IM0	I	Data bus Select Pin, set as High level "1". 	[Note4-1]
50	IM1	I	Data bus Select Pin, set as High level "1". 	[Note4-1]
51	GND	-	Power ground	

[Note4-1] IM1 / IM0 

IM1	IM0	SRAM	Register	Remarks
1	1	24bit-RGB interface, D[23:0]	16-bit SPI, SDI/SDO Serial data, SCL rising trigger DB23~DB16: R7~R0 DB15~DB8: G7~G0 DB7~DB0: B7~B0	

## 5. Absolute maximum ratings

Table5-1 Absolute maximum ratings

GND=0V

Parameter		Symbol	MIN	MAX	Unit	Remark
Power Supply Voltage	Analog	VCI	-0.3	+4.4	V	Ta=25deg.C
	Digital	IOVCC	-0.3	+4.4	V	Ta=25deg.C
Input Signal		VI	-0.3	IOVCC+0.5	V	Ta=25deg.C
Output Signal		VO	-0.3	IOVCC+0.5	V	Ta=25deg.C
Back Light Input Current		ILEDK	-0.0002	30	mA	Ta=25deg.C
Back Light Input Voltage		VLEDK	-	3	V	Ta=25deg.C
Storage Temperature		Tstg	-30	80	deg.C	[Note5-1,2]
Operating Temperature		Topr1	-20	70	deg.C	[Note5-1,2,3]

[Note5-1] This rating applies to all parts of the module and should not be exceeded.

[Note5-2] Avoid dew condensation on the module.

Otherwise electrical current leaks will occur , and it cannot meet the specifications.

[Note5-3] The operating temperature guarantees only operation of the circuit. For contrast, speed of response, and other factors related to display quality are determined in the circumstances with Ta=25deg.C .

**6. Electrical characteristics(DC Characteristics)**

6-1 TFT-LCD panel driving section

Table6-1

GND=0V , Ta=25°C

Parameter	Symbol	Min	Typ	Max	Unit	Remark
Power Supply Voltage(Analog)	VCI	2.6	2.8	3.3	V	[Note6-1]
Power Supply Voltage(Didital)	IOVCC	1.7	1.8	3.3	V	[Note6-1]
Input Voltage(Low)	VIL	0	-	0.3IOVCC	V	[Note6-1]
Input Voltage(High)	VIH	0.7IOVCC	-	IOVCC	V	[Note6-1]
Input Current(Low)	IIL	-10	-	-	uA	
Input Curent(High)	IIH	-	-	10	uA	
Output Voltage(Low)	VOL	0	-	0.2IOVCC	V	IOL=+0.1mA
Output Voltage(High)	VOh	0.8IOVCC	-	IOVCC	V	IOH=-0.1mA
Power Consumption	Pnorm	-	75	-	mW	[Note6-1]
	PSLEEP	-	10	-	mW	[Note6-1]
	PDeepsleep	-	1.0	-	mW	[Note6-1]

[Note6-1]

1. Conditions : Ta=25deg.C,VCI=2.8V,IOVCC=1.8V,Refresh rate=60Hz,Ta=-20 to +70deg.C operational

2. Pnorm: Power Consumption of normal display mode.

PSLEEP: Power Consumption of Sleep mode.

PDeepsleep: Power Consumption of Deep sleep mode.

6-2 LED back light driving section

Table6-2

GND=0V , Ta=25°C

Parameter	Symbol	Min	Typ	Max	Unit	Remark
Back Light Input Current	ILB	-	20	-	A	[Note6-2,3]
Back Light Input Voltage	VBL	24.8	25.2	25.6	V	[Note6-2]
Back Light Power Copsuption	PBL	-	504	840	mW	[Note6-4]

[Note6-2] Apply to terminal of LEDK

[Note6-3] For better LED Backlight driving quality, it is recommended to utilize the adaptive boost

Converter with current balancing function to drive LED Backlight.

[Note6-4]  $P_{BL} = I_{BL} \times V_{BL}$  (Without LED converter transfer efficiency)

[Note6-5] Ambient Temperature – Allowable Forward Current

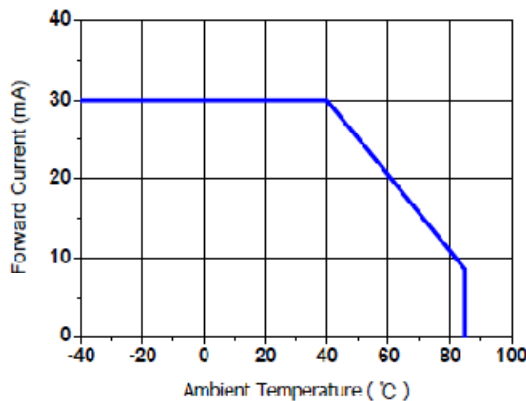



**7. Electrical characteristics (AC Characteristics/FUNCTIONAL DESCRIPTION)**

7-1 Input Data Signals and Display Position on the screen

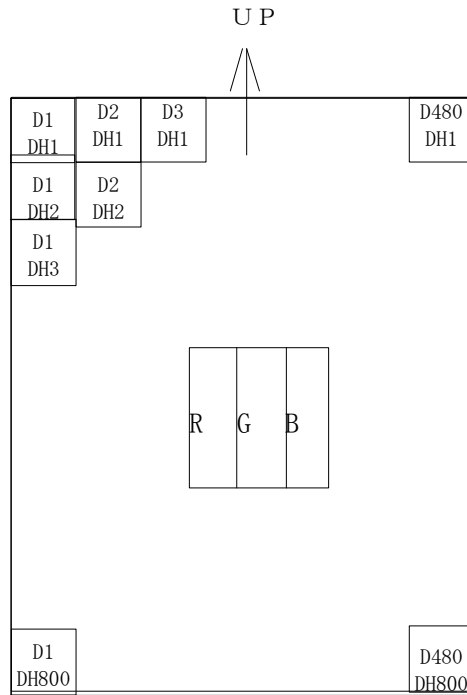

Display position of input data (H,V)

7-2. Serial Interface Characteristics

Serial Interface detail information refer to LCD driver IC specification sheet.



7-2-1 Serial Interface Timing Diagrams

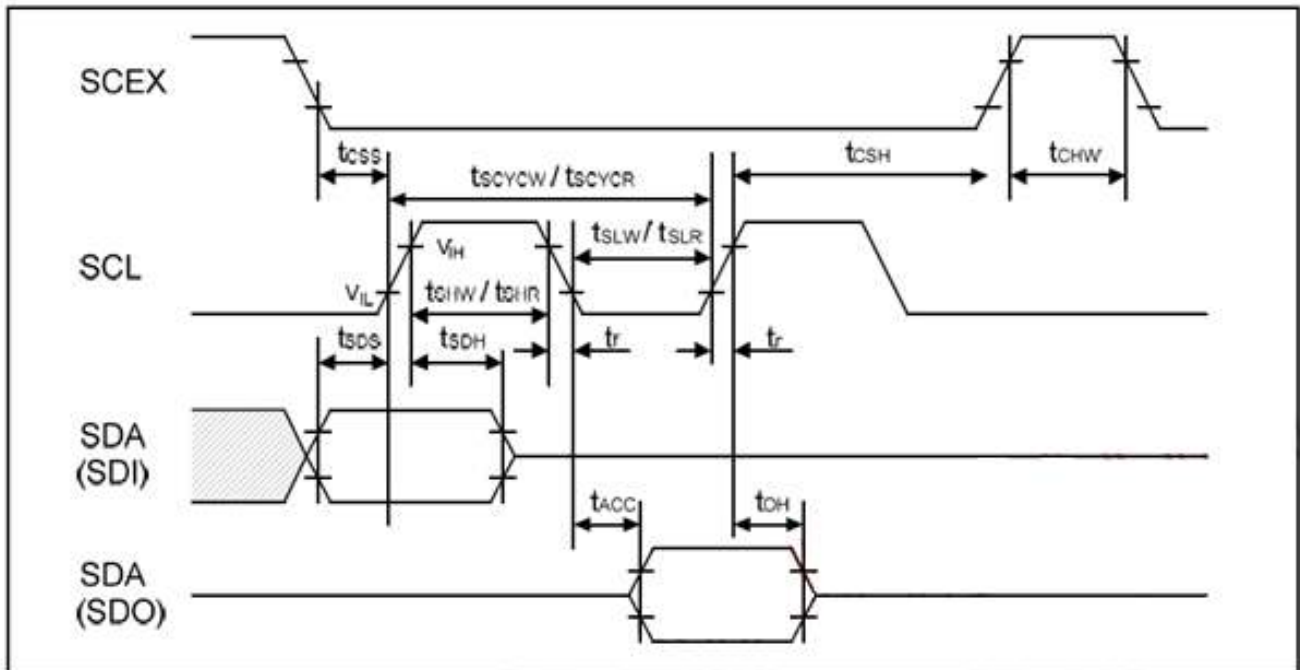

Table7-2

Signal	Symbol	Parameter	MIN	MAX	Unit	Remark
SCL	tSCYW	Serial clock cycle(Write)	100	-	ns	
	tSHW	SCL"H"pulse width(Write)	40	-	ns	
	tSLW	SCL"L"pulse width(Write)	40	-	ns	
	tSCYCR	Serial clock cycle(Read GRAM)	300	-	ns	
	tSHR	SCL"H"pulse width(Read GRAM)	140	-	ns	
	tSLR	SCL"L"pulse width(Read GRAM)	140	-	ns	
	tSCYCR	Serial clock cycle(Read ID)	300	-	ns	
	tSHR	SCL"H"pulse width(Read ID)	140	-	ns	
	tSLR	SCL"L"pulse width(Read ID)	140	-	ns	
SDI(SDO)	tSDS	Data setup time	20	-	ns	
	tSDH	Data hold time	20	-	ns	
	tACC	Access time		120	ns	
	tOH	Output disable time	5	-	ns	
CSX	tCHW	Chip select "H" pulse width	45	-	ns	
	tCSS	Chip select setup time	20	-	ns	
	tCSH	Chip select hold time	20	-	ns	

[Note7-1] VCI=2.6V to 3.3V, IOVCC=1.7V to 4.8V, GND=0V, Ta=-30 to 70 deg.C

[Note7-2] The input signal rise time and fall time (tr, tf) is specified at 15 ns or less.

Logic high and low levels are specified as 20% and 80% of VDDI for Input signals.

### 7-3. RGB Interface Characteristics

RGB Interface more detail information refer to LCD driver IC specification sheet.

#### 7-3-1 RGB Interface General Timing Diagram

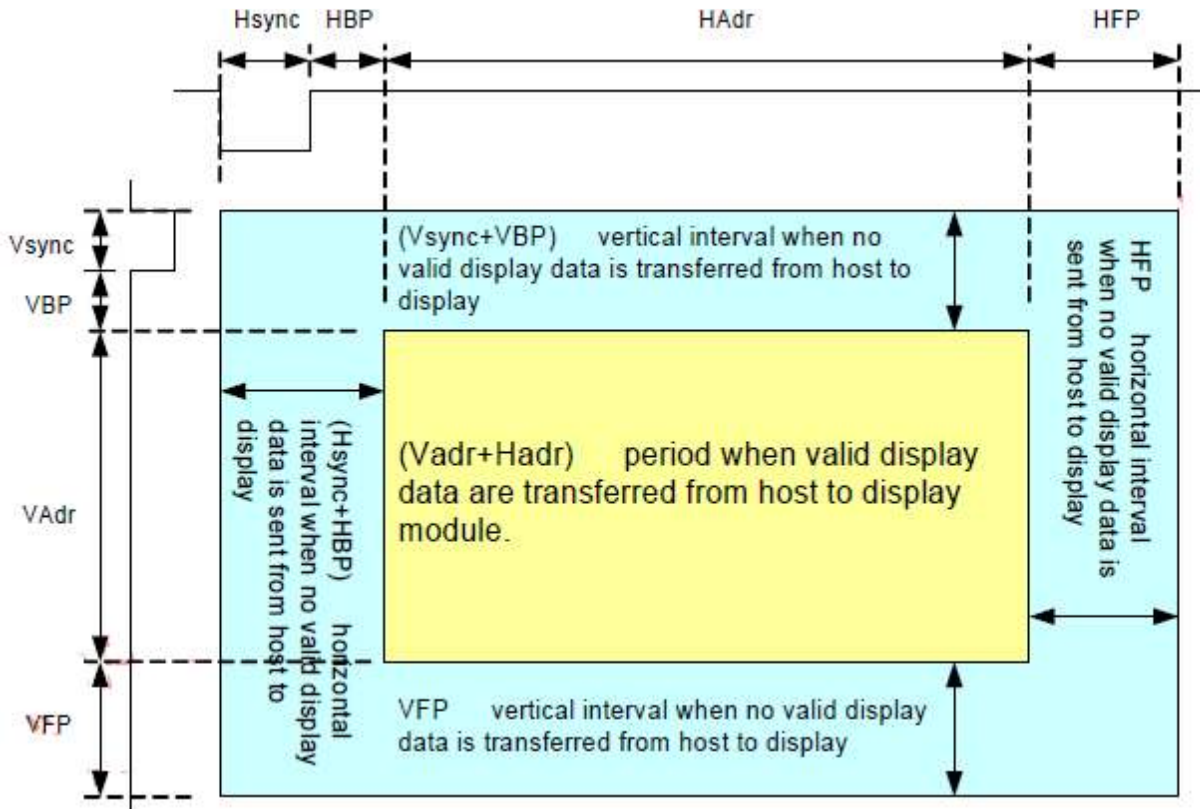

7-3-2 Video signal data writing method in RGB Interface

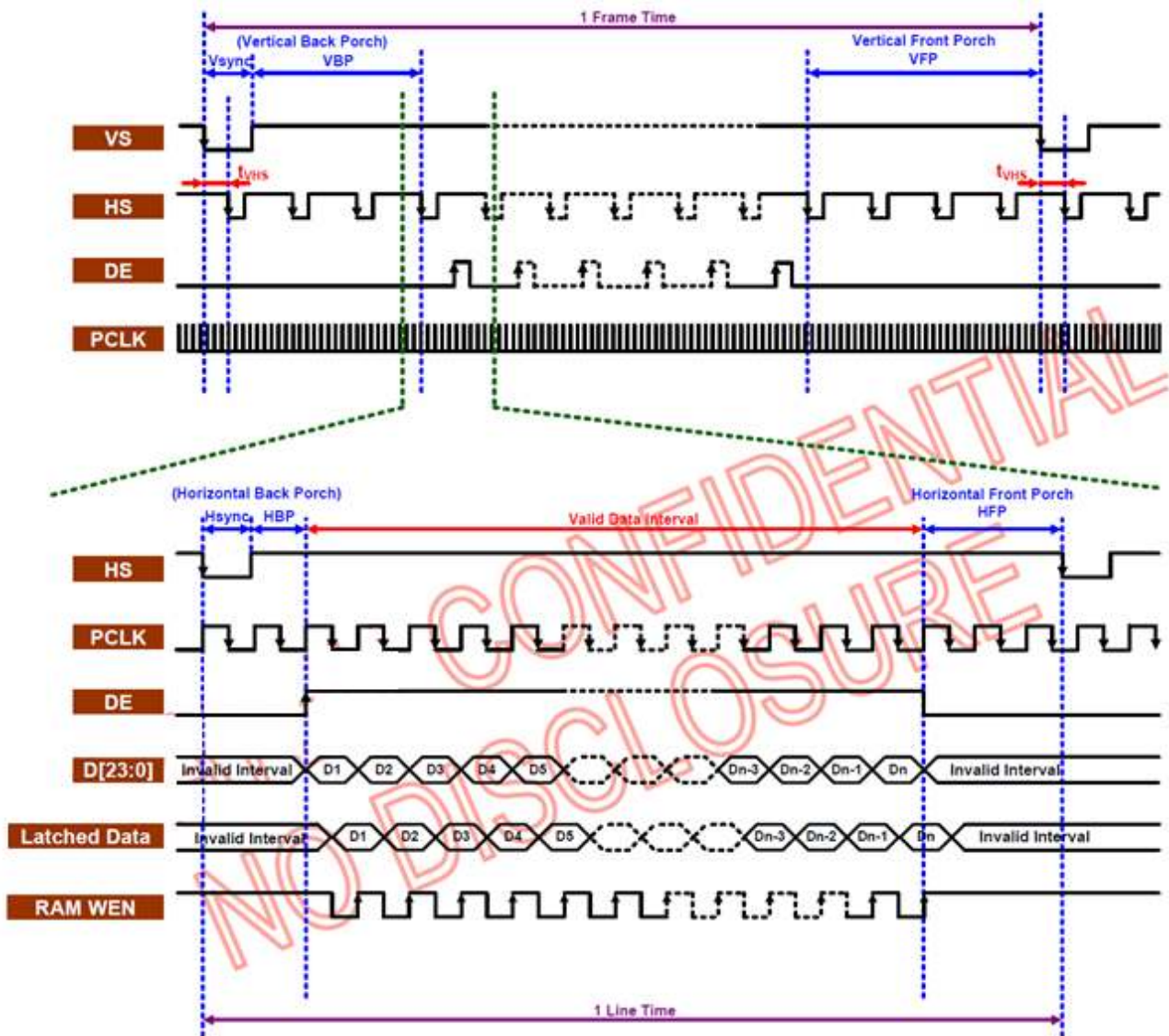

Notes:

1. Constraint:

V-Back Porch (Vsync+VBP)  $\geq$  5 HS lines, V-Front-Borch (VFP)  $\geq$  2 HS lines

H-Back Porch (Hsync+HBP)  $\geq$  5 PCLK clocks, H-Front-Porch (HFP)  $\geq$  2 PCLK clocks

2. tVHS  $\geq$  400ns

Note2:

RGB interface with SPI Timing Sequence is refer to LCD driver IC specification sheet.

Parameters	Symbols	Min.	Typ.	Max.	Units
PCLK Cycle	tDCYC	33	49.8	125	ns
Pixel Clock Low Duration	tDLW	11	-	-	ns
Pixel Clock High Duration	tDHW	11	-	-	ns
Horizontal Synchronization	Hsync	5	9	-	PCLK
Horizontal Back Porch	HBP	5	30	-	PCLK
Horizontal Address	Hadr	480	480	-	PCLK
Horizontal Front Porch	HFP	5	16	-	PCLK
Vertical Synchronization	Vsync	2	5	-	Line
Vertical Back Porch	VBP	2	3	-	Line
Vertical Address	Vadr	800	800	-	Line
Vertical Front Porch	VFP	2	3	-	Line
Vertical Frequency	VF	55	60	65	Hz
Horizontal Frequency	HF	-	-	-	KHz
PCLK Frequency	PF	20.3	23.5	28.1	MHz
Vsync setup Time	tVSYNS	10	-	-	ns
Vsync hold Time	tVSYNH	10	-	-	ns
Hsync setup Time	tHSYNS	10	-	-	ns
Hsync hold Time	tHSYNH	10	-	-	ns
Data setup Time	tDDS	10	-	-	ns
Data Hold Time	tDDH	10	-	-	ns

7-3-3 Write data for RGB interface bus width set

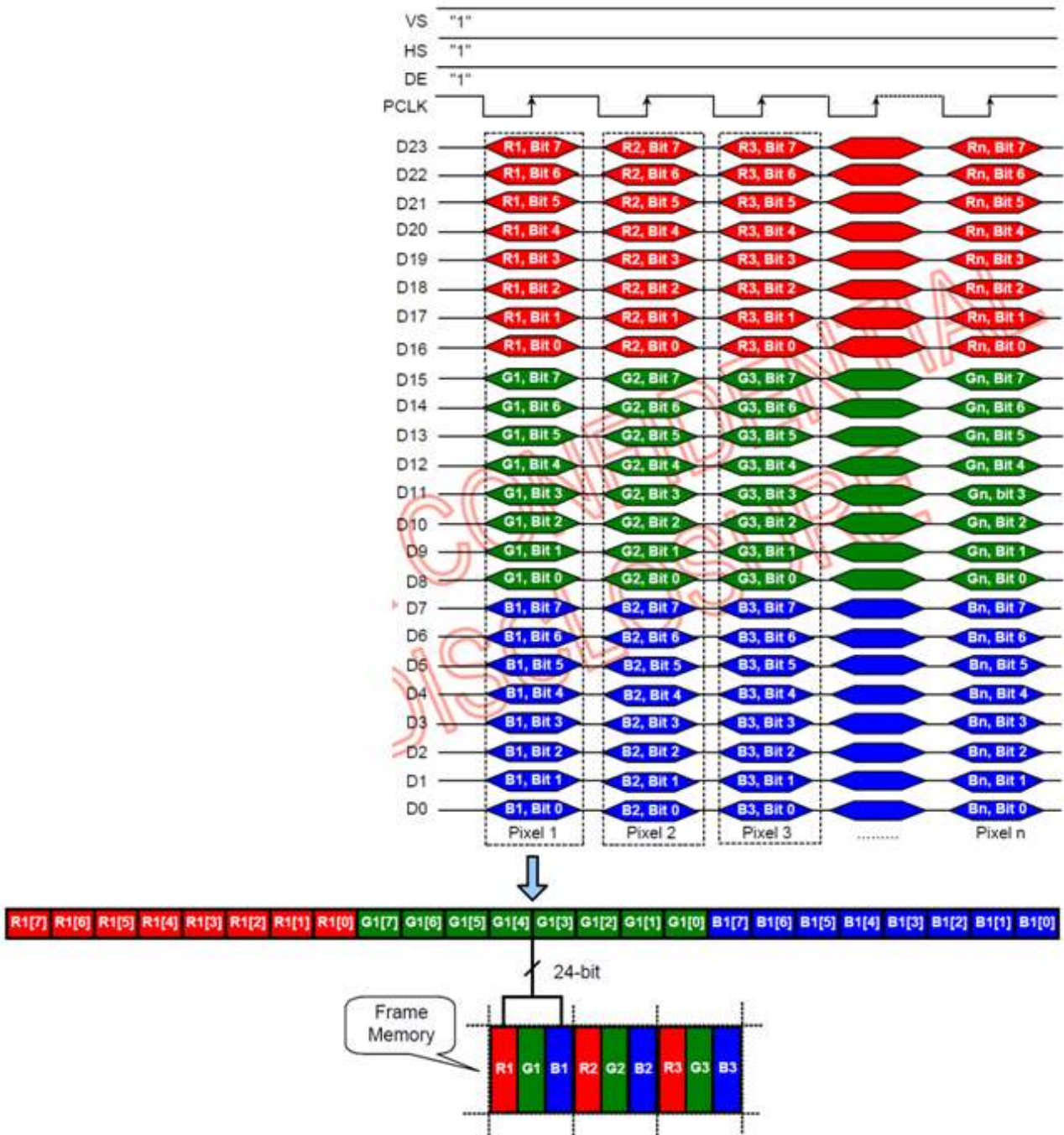



7-3-4 Detailed Timing for RGB interface

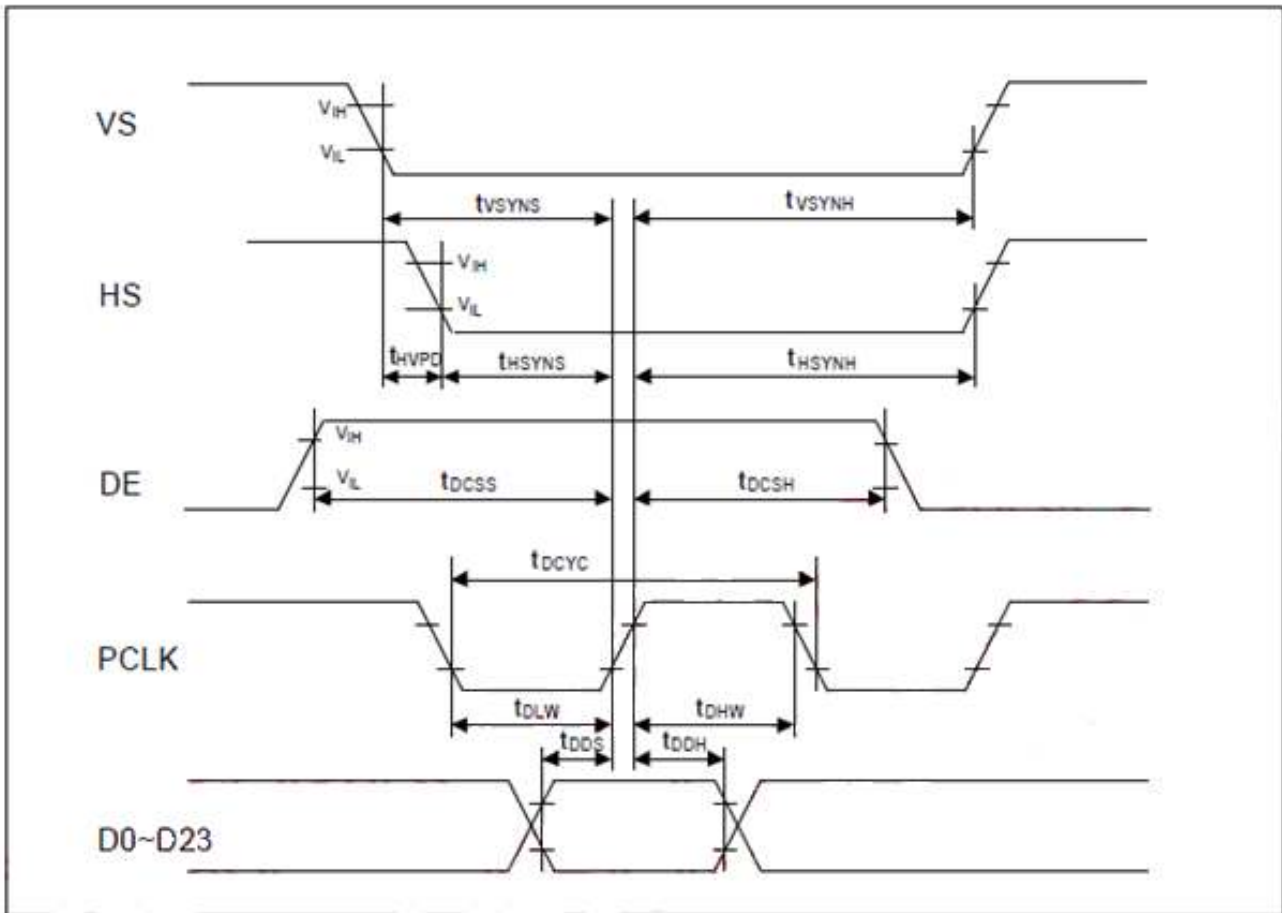

Table7-3

Signal	Symbol	Parameter	MIN	MAX	Unit	Remark
VS	tVSYNS	VSYNC setup time	10	-	ns	
	tVSYNH	VSYNC hold time	10	-	ns	
HS	tHSYNS	HSYNC setup time	10	-	ns	
	tHSYNH	HSYNC hold time	10	-	ns	
	tHVPD	HSYNC to VSYN falling edge	400	-	ns	
PCLK	tDCYC	PCLK cycle time	33	125	ns	
	tDLW	PCLK "L" pulse width	11		ns	
	tDHW	PCLK "H" pulse width	11	-	ns	
	tDFREQ	PCLK frequency	8	-	ns	
DE	tDCSS	DE setup time	10	-	ns	
	tDCSH	DE hold time	10	-	ns	
D0-D23	tDDS	RGB data setup time	10	-	ns	
	tDDH	RGB data hold time	10	-	ns	

[Note7-3] VCI=2.6V to 3.3V, IOVCC=1.7V to 4.8V, GND=0V, Ta=-30 to 70 deg.C

[Note7-4] The input signal rise time and fall time (tr, tf) is specified at 15 ns or less.

Logic high and low levels are specified as 20% and 80% of VDDI for Input signals.





### 10. Initial Sequence

During power on, 'RESX' must be applied for a minimum of 10us after both VCI and IOVCC have been applied. 'RESX' can be undefined during power-on but must be applied subsequently to ensure correct LCD controller operation. IOVCC and VCI can be applied in any order.

During power-off, if the LCD controller is in 'Sleep Out' mode, VCI and IOVCC must be powered down a minimum of 120ms after RESX has been released. If the LCD controller is in 'Sleep In' mode, IOVCC and VCI can be powered down a minimum of 0ms after 'RESX' has been released. IOVCC and VCI can be powered down in any order.

'CSX' can be applied at any time. 'RESX' has priority over 'CSX'.

10-1 Case 1 - RESX line is held high or unstable by host at power-on

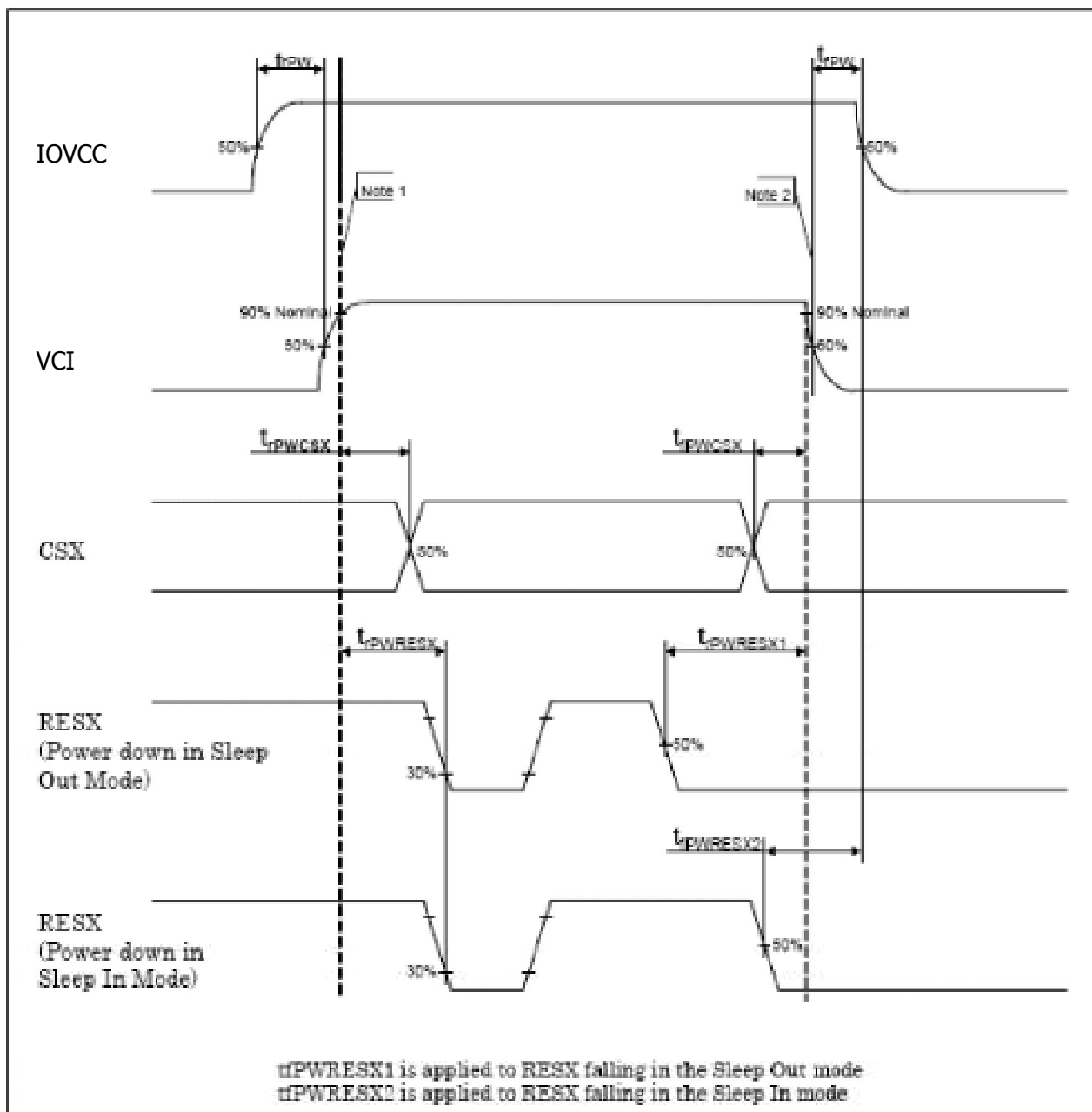

Note 1. Time when the latter signal rises up to 90% of its typical value, e.g. when VCI comes later.

This time is defined at the cross point of 90% of VCI Typ, not VCI Min, (see Table4).

Note 2. Time when the former signal falls down to 90% of its typical value, e.g. when VCI falls earlier. This time is defined at the cross point of 90% of VCI Typ, not VCI Min.

Parameter	Value
trPW	+/- no limit
tFPW	+/- no limit
trPWCSX	+/- no limit
tFPWCSX	+/- no limit
trPWRESX	+ no limit
tFPWRESX1	min 120mS
tFPWRESX2	+ no limit

10-2 Case 2 - RESX line is held low by host at power-on

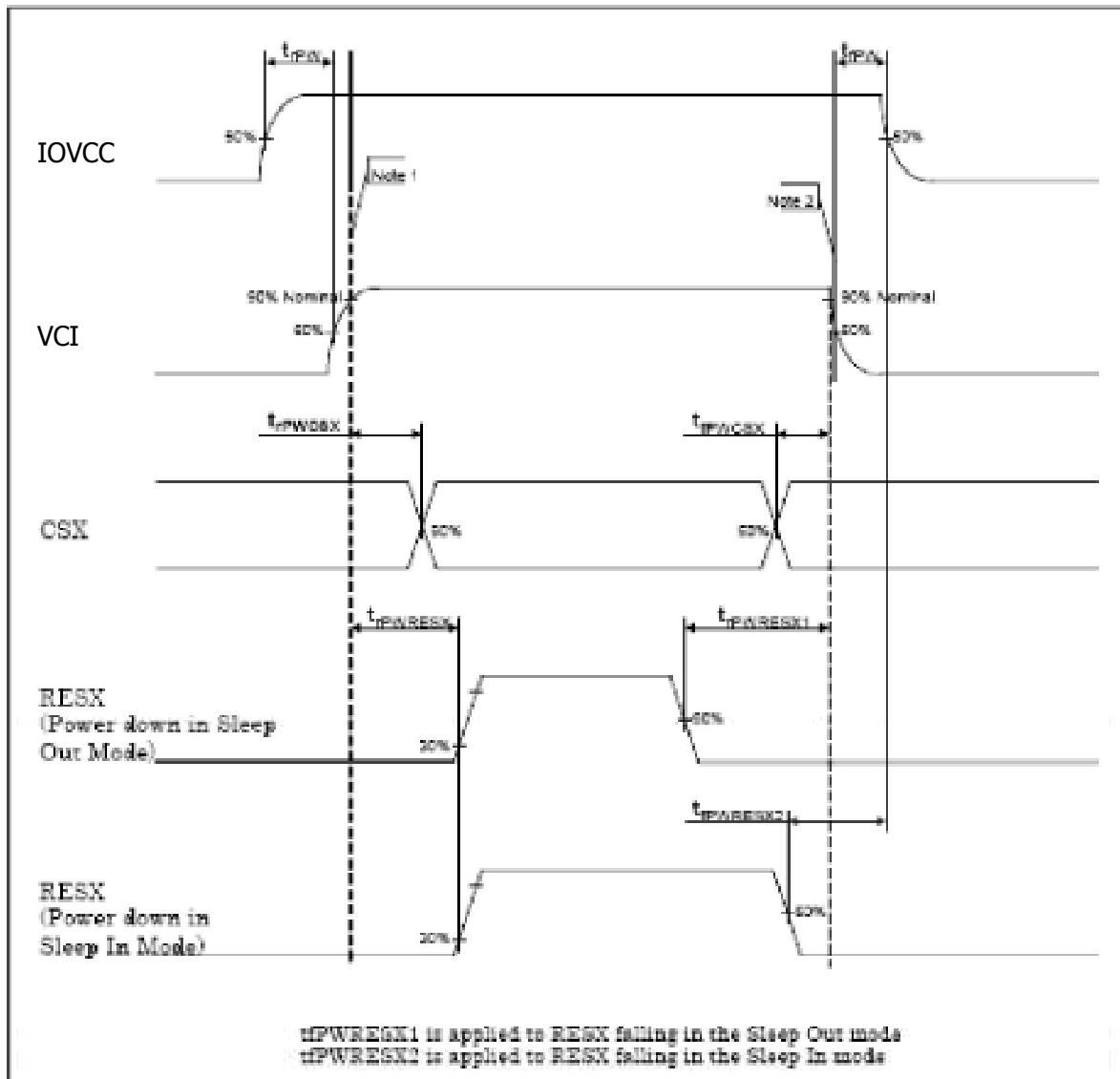

Note 1. Time when the latter signal rises up to 90% of its typical value, e.g. when VCI comes later.

This time is defined at the cross point of 90% of VCI Typ, not VCI Min, (see Table4).

Note 2. Time when the former signal falls down to 90% of its typical value, e.g. when VCI falls earlier.

This time is defined at the cross point of 90% of VCI Typ, not VCI Min, (see Table4).

<b>Parameter</b>	<b>Value</b>
trPW	+/- no limit
tfPW	+/- no limit
trPWCSX	+/- no limit
tfPWCSX	+/- no limit
trPWRESX	min 10 us
tfPWRESX1	min 120mS
tfPWRESX2	min 0mS

#### Note

There will be no damage to the display module if the above power sequences are not met.

There will be no abnormal visible effects on the display panel during the sequence.

There will be no abnormal visible effects on the display between the end of power on sequence and before entering Sleep Out mode. Also between entering Sleep In mode and power off sequence.

There are no limits for RESX timings during power on sequence. (e.g. from the undefined level to High or low, when the first RESX low pulse after VDD and IOVCC are powered-on, etc.)

#### 10-3 Uncontrolled Power-off

Uncontrolled power-off (e.g. the battery is removed without following the proper power-off sequence), will not damage the LCD module or cause the LCD module to inflict any damage on the host.

There will not be any abnormal visible effects left on the display after a period of 5 seconds following an uncontrolled power-off. The display will remain blank until the power on sequence is initiated.

### 11. Internal Display Backlight Control (PWM Control, CABC)

PWM control, CABC(Content Adaptive Brightness Control) function detail information refer to LCD driver IC specification sheet.

#### *LQ040Y3DX80 Baclight control application*

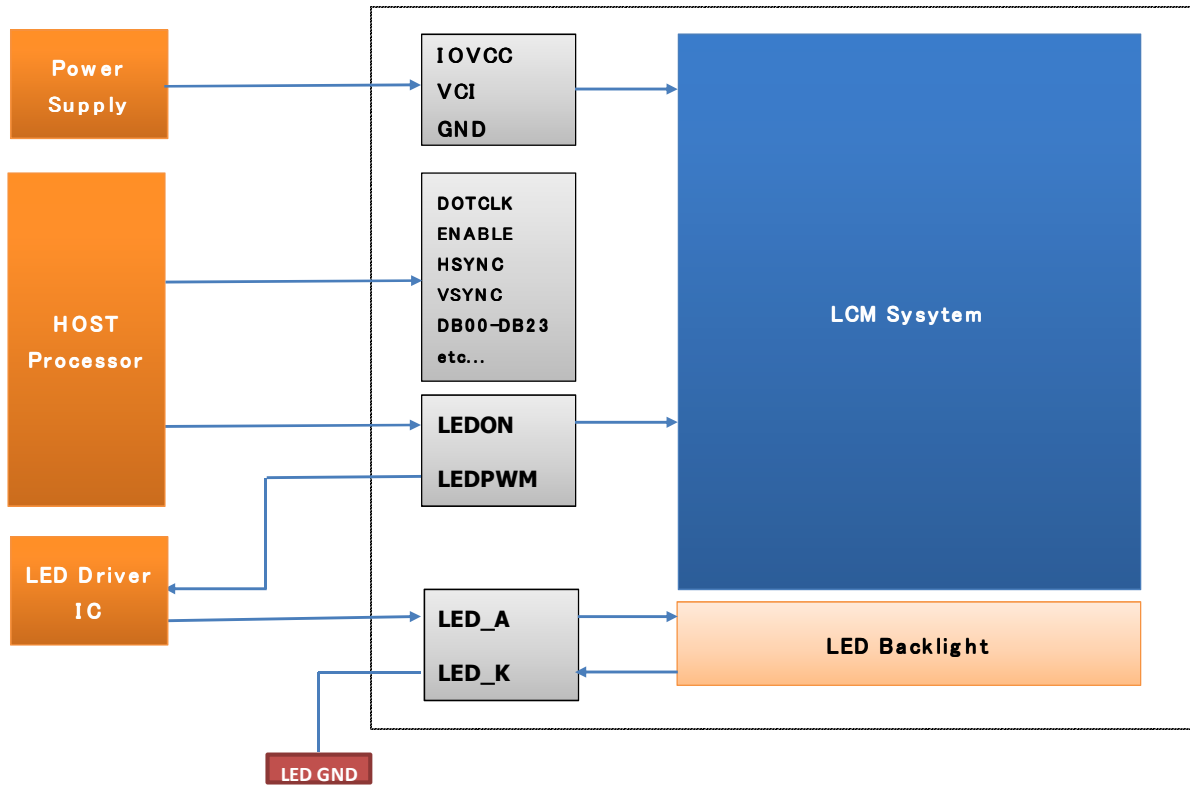

## 12. Serial Interface

The serial interface, the trigger edge of serial clock (SCL) is rising edge . The serial interface is used to communication between the micro controller and the LCD driver chip. It contains CSX (chip select), SCL (serial clock), SDI (serial data input) and SDO (serial data output). Serial clock (SCL) is used for interface with MPU only, so it can be stopped when no communication is necessary. If the host places the SDI line into high-impedance state during the read intervals, then the SDI and SDO can be tied together.

### 12-1 Write Mode

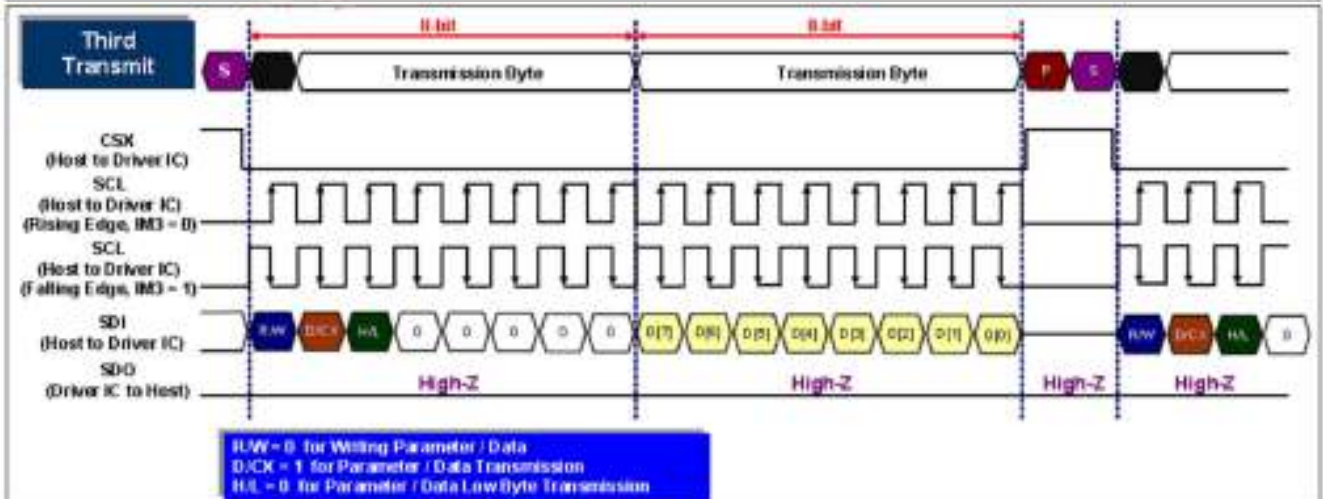
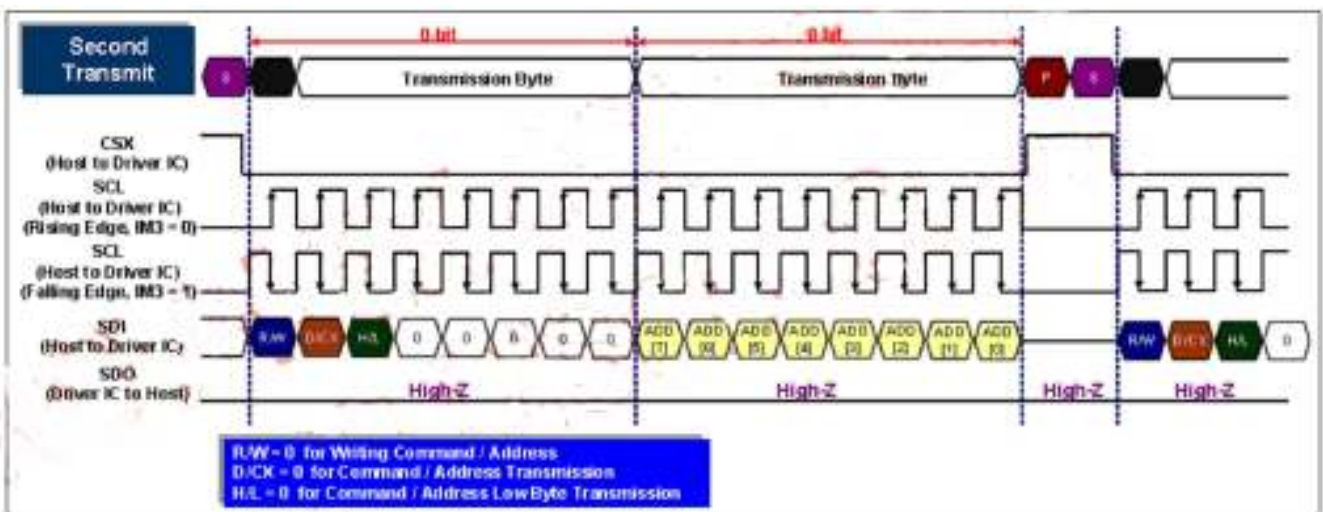
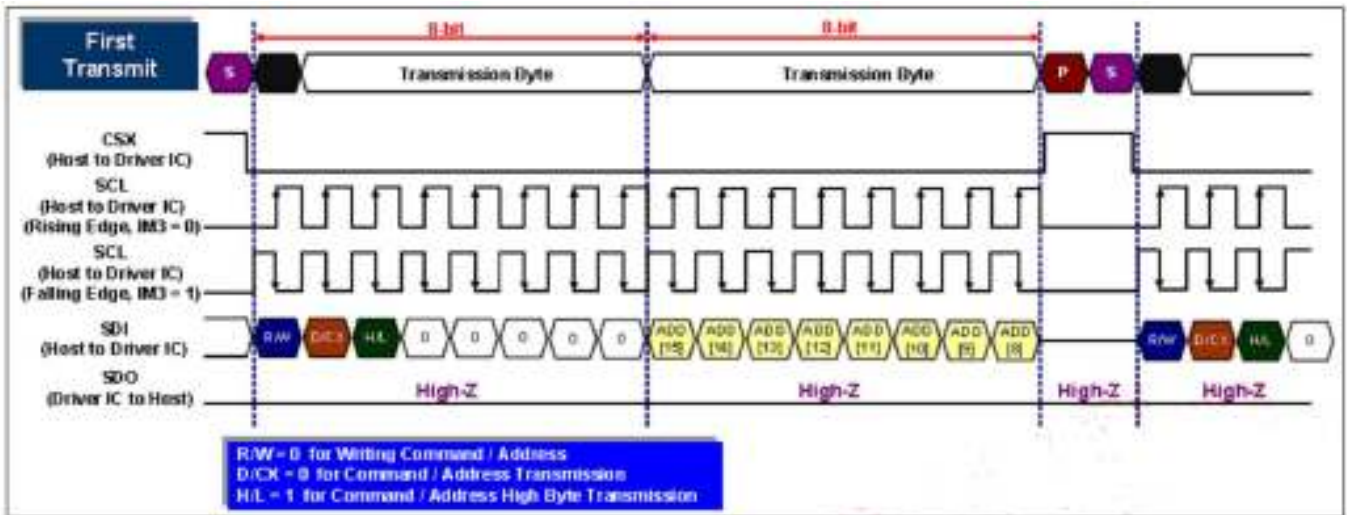

12-2 Read Mode

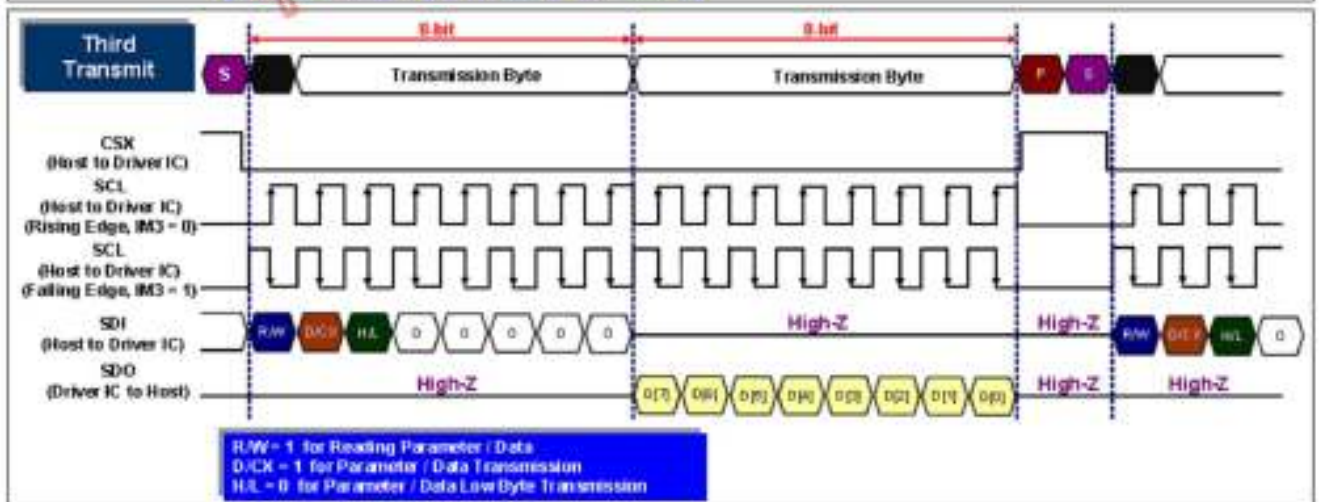
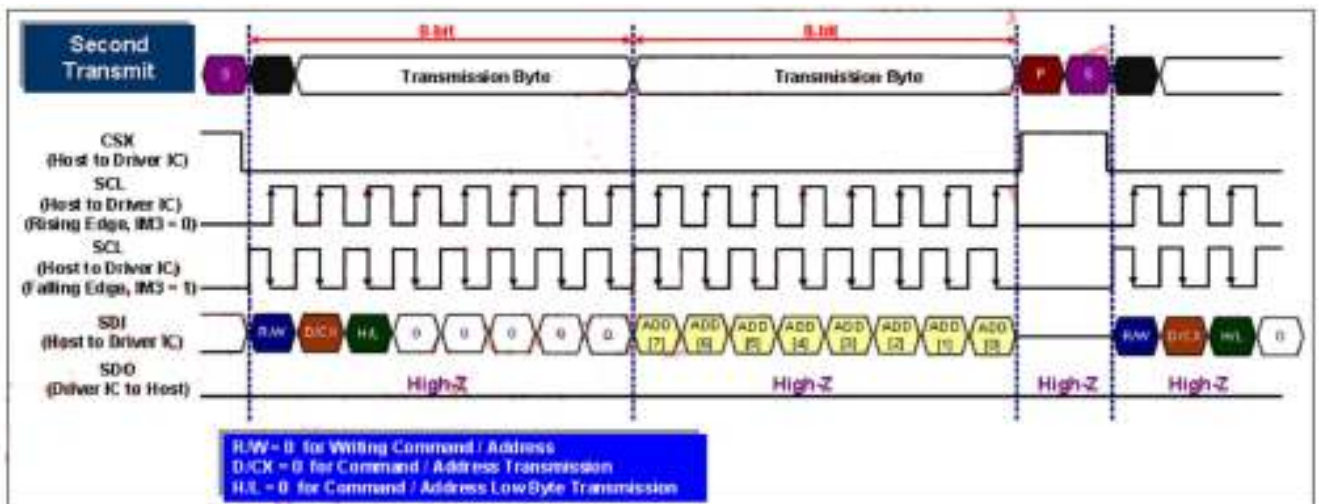
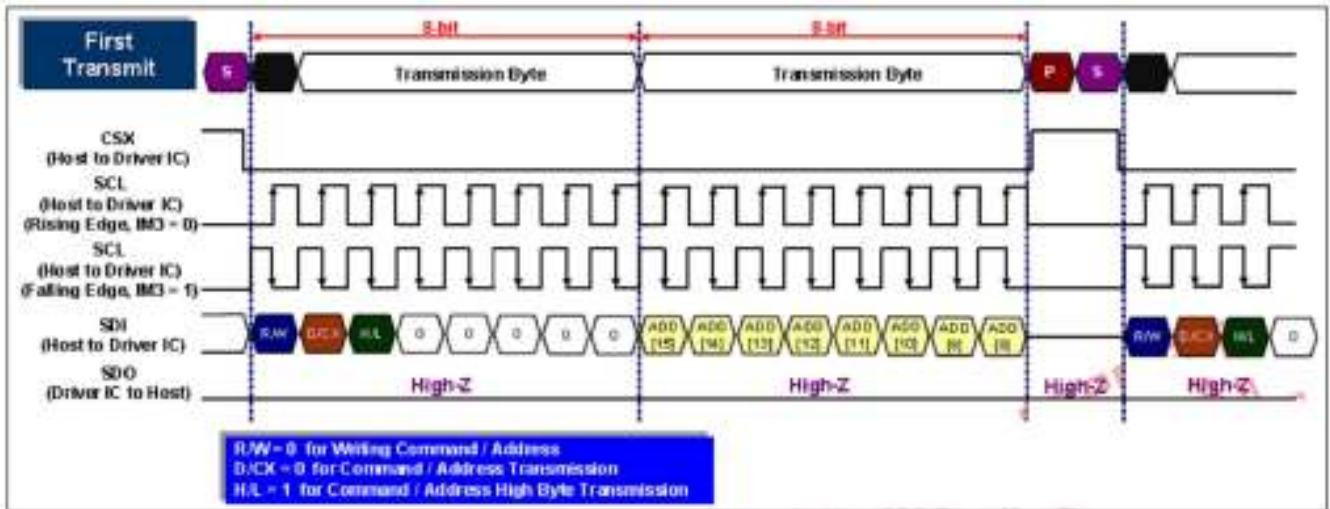

**13. Optical characteristics**

Table13-1 Optical characteristics

Ta=25°C

Item	Symbol	Condition	Min.	Typ.	Max.	Unit	Remark
Response time	Tr+Td	$\theta=0^\circ$	-	40	-	ms	Note13-3
Brightness	Br	$\theta=0^\circ$	300	320	-	Cd/m <sup>2</sup>	Note13-4
Contrast ratio	CR	$\theta=0^\circ$	600	800	-	-	Note13-2
Viewing Angle	Top	CR $\geq$ 10	80	85	-	degree	Note13-1
	Bottom		80	85	-		
	Left		80	85	-		
	Right		80	85	-		
White Chromaticity	X	CIE	0.25	0.30	0.35	-	Note13-4
	Y		0.27	0.32	0.37	-	Note13-4
NTSC ratio		-	-	70	-	%	Note13-4

[Note13-1]

The optical characteristics measurements are operated under a stable luminescence (I<sub>LED</sub> = 20mA) and a dark condition.

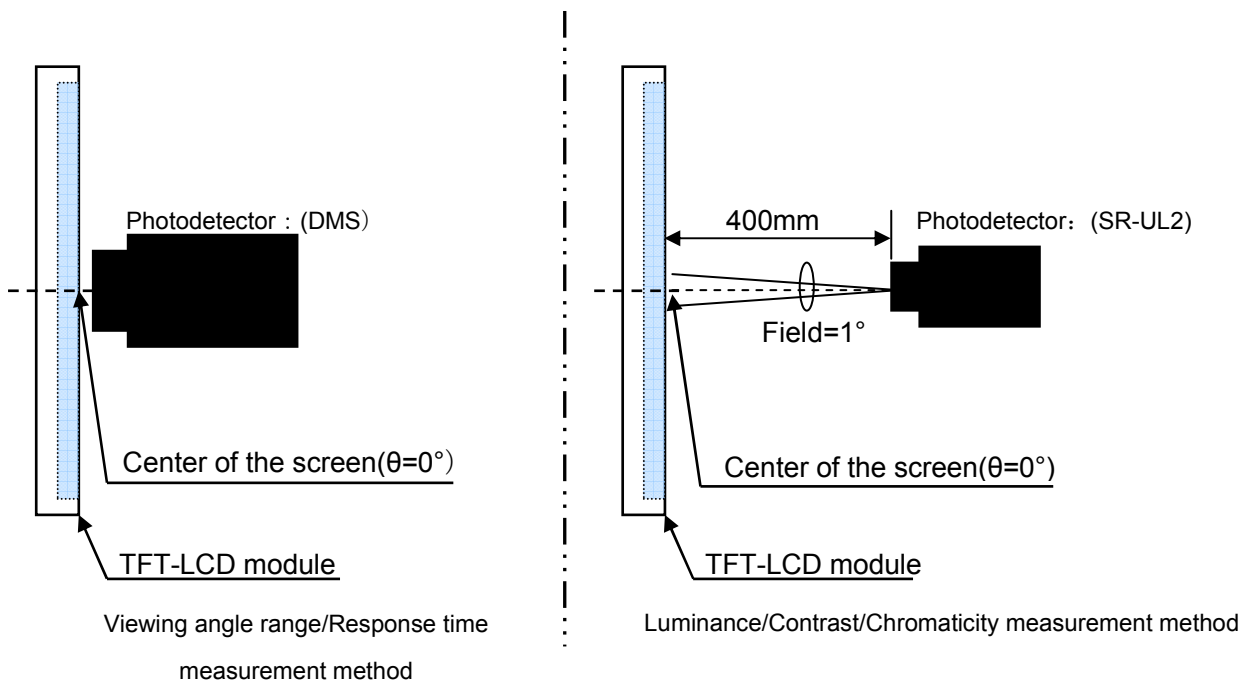

[Note13-2] Definitions of viewing angle range

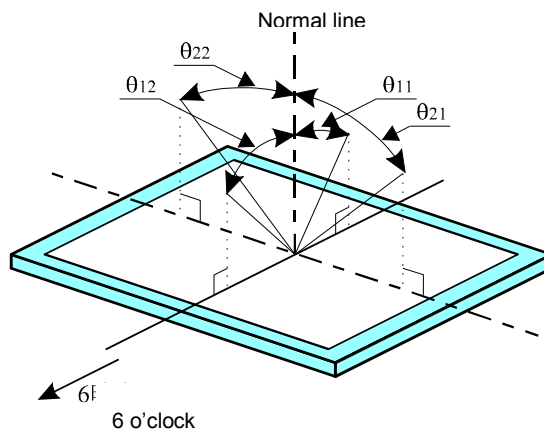

[Note13-3] Definition of contrast ratio

The contrast ratio is defined as the following

$$\text{Contrast ratio (CR)} = \frac{\text{Luminance (brightness) with all pixels white}}{\text{Luminance (brightness) with all pixels black}}$$

[Note13-4] Definition of response time

The response time is defined as the following figure and shall be measured by switching the input signal for "black" and "white"

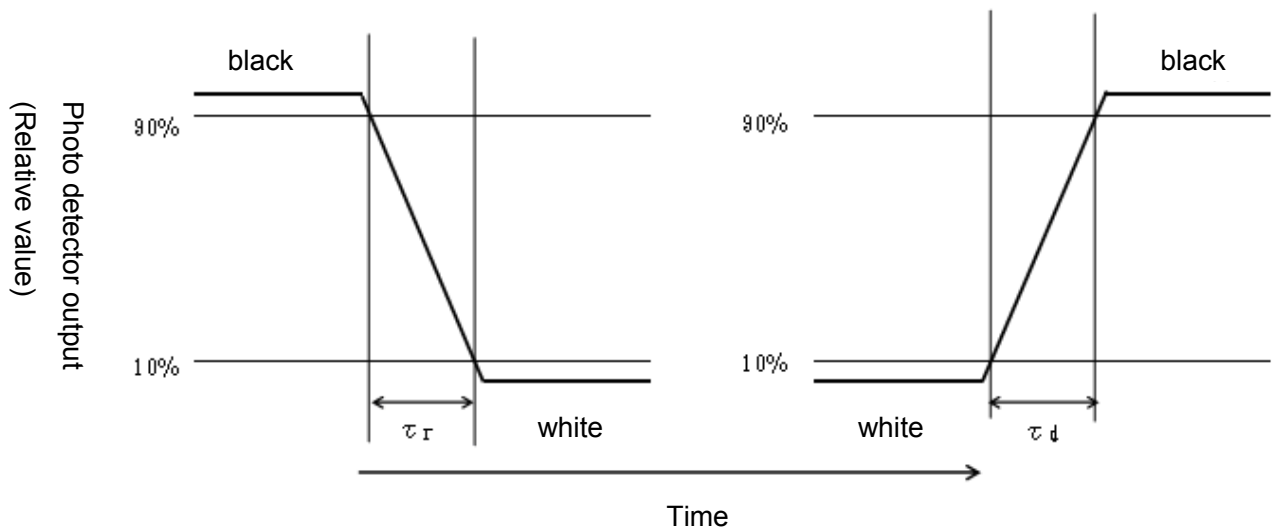

[Note13-5] This shall be measured at center of the screen.



**14. Display quality**

The display quality of the color TFT-LCD module shall be in compliance with the Incoming Inspection Standards for TFT-LCD.

**15. Mechanical characteristics**

External appearance

No extreme defect exists.

**16. For handling and system design**

- (1) Do not scratch the surface of the polarizer film as it is easily damaged.
- (2) If the cleaning of the surface of the LCD panel is necessary, wipe it swiftly with cotton or other soft cloth. Do not use organic solvent as it damages polarizer.
- (3) Water droplets on polarizer must be wiped off immediately as they may cause color changes, or other defects if remained for a long time.
- (4) Since this LCD panel is made of thin glass, dropping the module or banging it against hard objects may cause cracks or fragmentation
- (5) Certain materials such as epoxy resin (amine's hardener) or silicone adhesive agent (de-alcohol or de-oxym) emits gas to which polarizer reacts (color change). Check carefully that gas from materials used in system housing or packaging do not hurt polarizer.
- (6) Liquid crystal material will freeze below specified storage temperature range and it will not get back to normal quality even after temperature comes back within specified temperature range. Liquid crystal material will become isotropic above specified temperature range and may not get back to normal quality. Keep the LCD module always within specified temperature range.
- (7) Do not expose LCD module to the direct sunlight or to strong ultraviolet light for long time.
- (8) If the LCD driver IC (COG) is exposed to light, normal operation may be impeded. It is necessary to design so that the light is shut off when the LCD module is mounted.
- (9) Do not disassemble the LCD module as it may cause permanent damage.
- (10) As this LCD module contains components sensitive to electrostatic discharge, be sure to follow the instructions in below.
  - ① Operators must wear anti-static wears to prevent electrostatic charge up to and discharge from human body.
  - ② Equipment and containers Process equipment such as conveyer, soldering iron, working bench and containers may possibly generate electrostatic charge up and discharge. Equipment must be grounded through 100Mohms resistance. Use ion blower.
  - ③ Floor is an important part to leak static electricity which is generated from human body or equipment. There is a possibility that the static electricity is charged to them without leakage in case of insulating floor, so the countermeasure(electrostatic earth: $1 \times 10^8 \Omega$ ) should be made.
  - ④ Humidity Proper humidity of working room may reduce the risk of electrostatic charge up and discharge. Humidity should be kept over 50% all the time.
  - ⑤ Transportation/storage Storage materials must be anti-static to prevent causing electrostatic discharge.
  - ⑥ Others Protective film is attached on the surface of LCD panel to prevent scratches or other damages. When removing this protective film, remove it slowly under proper anti-ESD control such as ion blower.
- (11) Hold LCD very carefully when placing LCD module into the system housing. Do not apply excessive stress or pressure to LCD module. Do not to use chloroprene rubber as it may affect on the reliability of the electrical interconnection.
- (12) Do not hold or touch LCD panel to flex interconnection area as it may be damaged.
- (13) As the binding material between LCD panel and flex connector mentioned in 12) contains an organic material, any type of organic solvents are not allowed to be used. Direct contact by fingers is also prohibited.
- (14) When carrying the LCD module, place it on the tray to protect from mechanical damage. It is recommended to use the conductive trays to protect the CMOS components from electrostatic discharge. When holding the module, hold the Plastic Frame of LCD module so that the panel, COG and other electric parts are not damaged.
- (15) Do not touch the COG's patterning area. Otherwise the circuit may be damaged.
- (16) Do not touch LSI chips as it may cause a trouble in the inner lead connection.
- (17) Place a protective cover on the LCD module to protect the glass panel from mechanical damages.
- (18) LCD panel is susceptible to mechanical stress and even the slightest stress will cause a color

change in background. So make sure the LCD panel is placed on flat plane without any continuous twisting, bending or pushing stress.

(19) Protective film is placed onto the surface of LCD panel when it is shipped from factory. Make sure to peel it off before assembling the LCD module into the system. Be very careful not to damage LCD module by electrostatic discharge when peeling off this protective film. Ion blower and ground strap are recommended.

(20) Make sure the mechanical design of the system in which the LCD module will be assembled matches specified viewing angle of this LCD module.

(21) This LCD module does not contain nor use any ODS (1,1,1-Trichloroethane, CCL4) in all materials used, in all production processes.

**17.Packaging Specification**

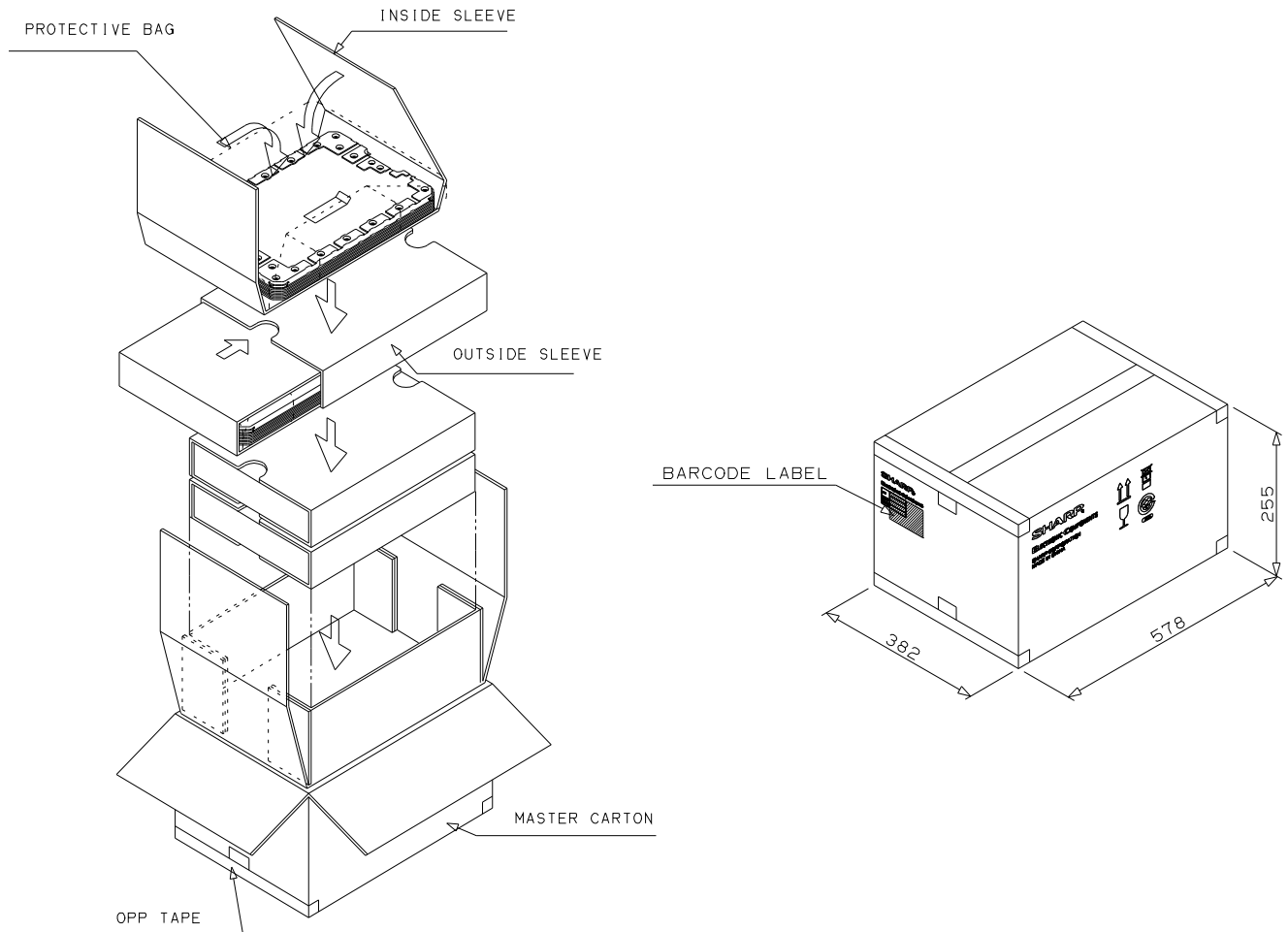
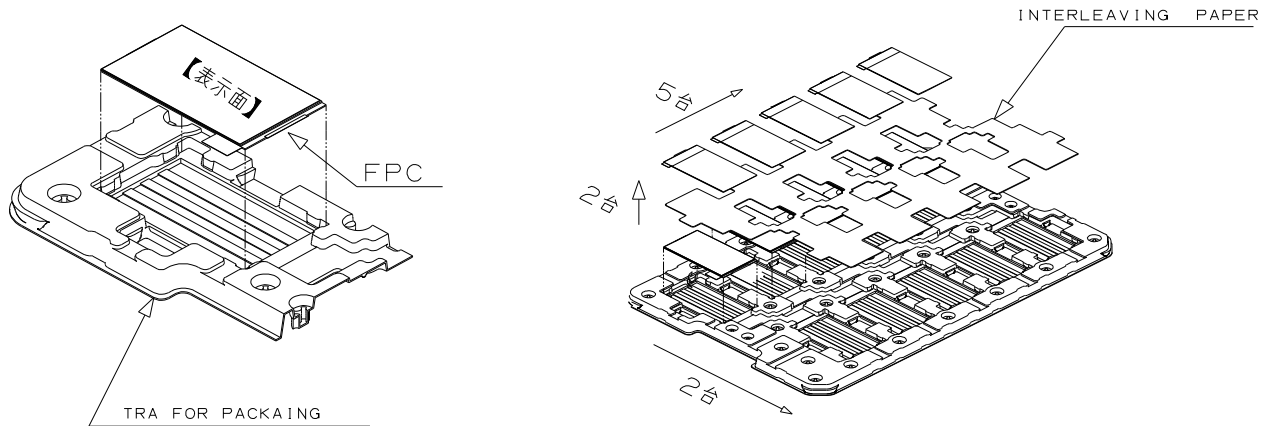

- (1) Packaging quantities  
320 modules per master carton
- (2) Packaging weight  
About 13.0 kg
- (3) Packaging outline dimensions  
578 mm×382 mm×255 mm (H)

**18. For operating LCD module**

- (1) Do not operate or store the LCD module under outside of specified environmental conditions.
- (2) At the shipment, adjust the contrast of each LCD module with electric volume. LCD contrast may vary from panel to panel depending on variation of LCD power voltage from system.
- (3) As opt-electrical characteristics of LCD will be changed, dependent on the temperature, the confirmation of display quality and characteristics has to be done after temperature is set at 25 °C and it becomes stable.

**19. Precautions for Storage**

- (1) Do not expose the LCD module to direct sunlight or strong ultraviolet light for long periods. Store in a dark place.
- (2) The liquid crystal material will solidify if stored below the rated storage temperature and will become an isotropic liquid if stored above the rated storage temperature, and may not retain its original properties. Only store the module at normal temperature and humidity (25±5°C,60±10%RH) in order to avoid exposing the front polarizer to chronic humidity.
- (3) Keeping Method
  - a. Don't keeping under the direct sunlight. b. Keeping in the tray under the dark place.

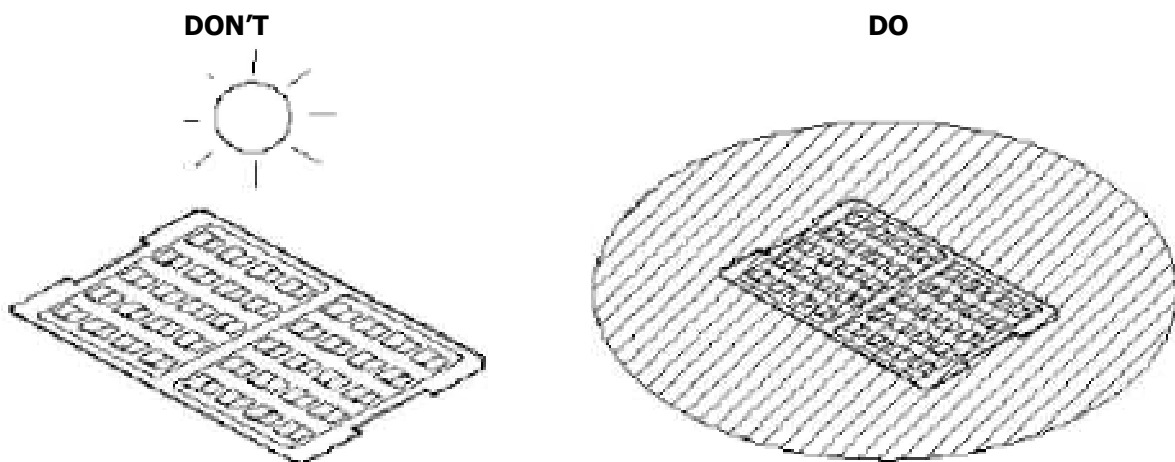

- (1) Do not operate or store the LCD module under outside of specified environmental conditions.
- (2) Be sure to prevent light striking the chip surface.

**20. Serial Number Label Identification**

LQ040Y3DX80    2 3 000001 A Q    SHARP

LCD Module Name

Production Year (1,2,3..... \*2012 → 2)

Production Month(1,2,3.....9,X,Y,Z \*March → 3)

Serial No(000001~)

Revision code(A,B,C.....)

Internal Code

**21. Reliability Test Items**

No.	Test items	Test conditions
(1)	Temperature Cycling Storage	-30°C(0.5h)-----80°C(0.5h)*1cycle      100 cycle
(2)	High Temp. Storage	Ta=80°C      240h
(3)	Low Temp. Storage	Ta=-30°C      240h
(4)	High Temperature & High Humidity Storage	Ta=60°C / 90%      240h
(5)	High Temp. Operation	Ta=70°C      240h
(6)	Low Temp. Operation	Ta=-20°C      240h
(7)	ESD	Discharge resistance: 0Ω Discharge capacitor:200Pf Discharge voltage: ±200V MAX Discharge 1 time to each input line "GND" of LCM is connected to GND of test system ground
(8)	Vibration test	Frequency range: 10Hz~55Hz Stroke: 1.5mm, Sweep: 10Hz~55Hz X, Y, Z 2hours for each direction (total 6 hours)
(9)	Shock test	980m/s <sup>2</sup> · 6ms , ±X ; ±Y ; ±Z 3 times for each direction ( JIS C0041, A-7 Condition C )      [Note20-2]

[Note21-1] In the standard condition, there shall be no practical problems that may affect the display function.

[Note21-2] Definition of X, Y, Z direction is shown as follows

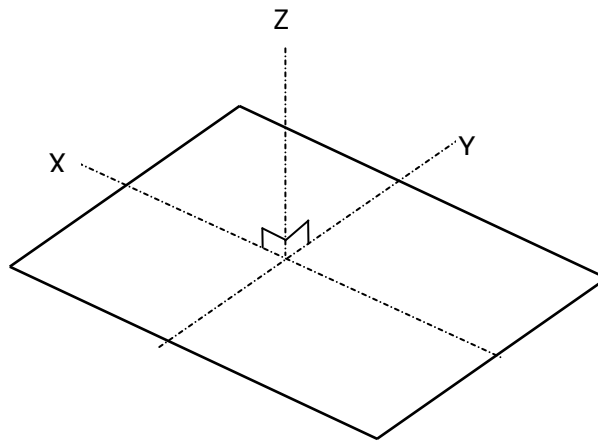

 **22. RoHS**

This TFT-LCD module is RoHS compliant products

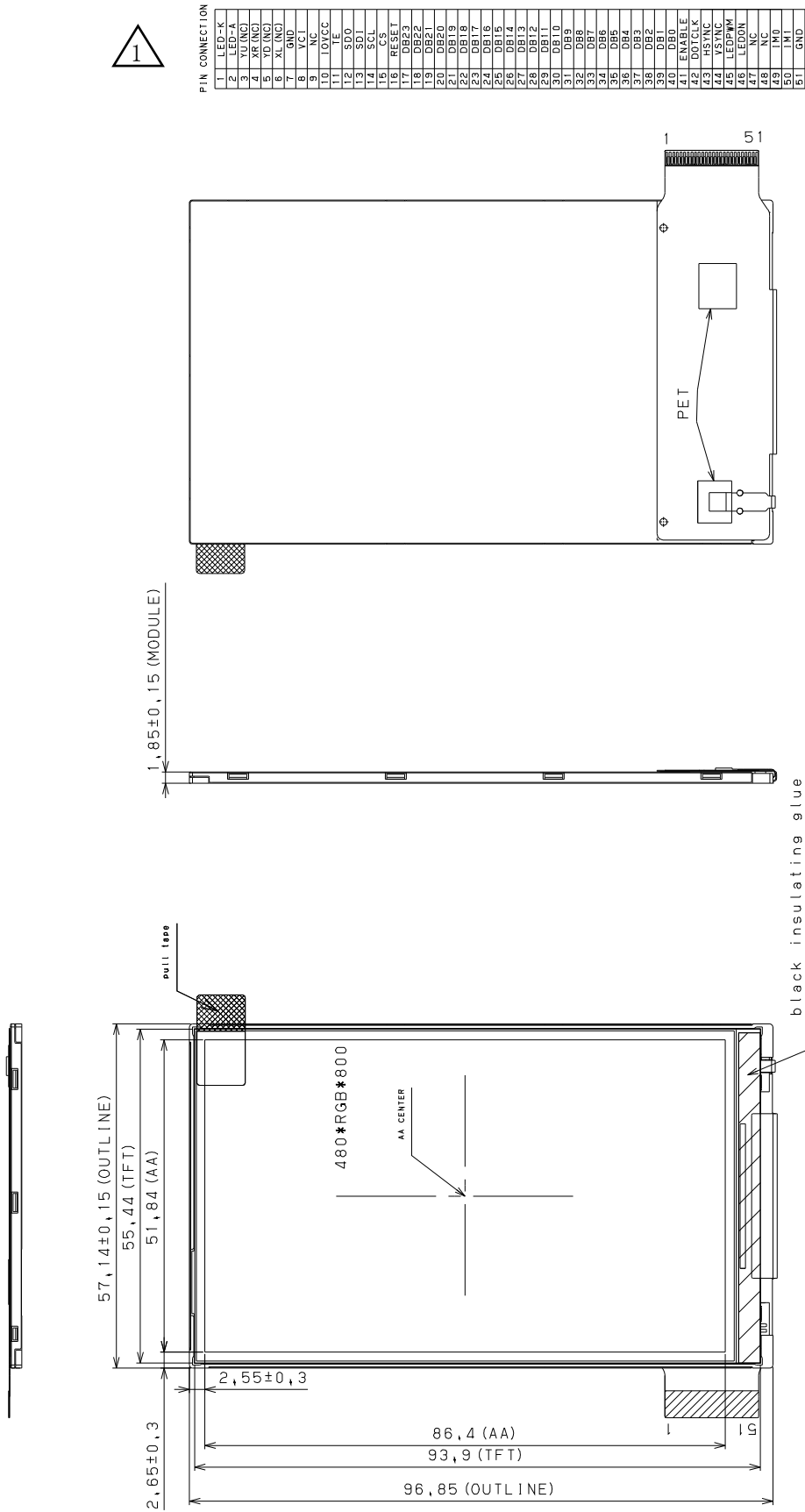

- Any foreign materials and contamination outside the Active Area are to be treated as "No-Count" at our inspections.
- Guarantee of appearance=LCD Active Area
- General tolerance is ±0,5.
- LCD-FPC,LED-FPC and bend larger than 0,6 in radius.
- Please design carefully to hide the polarizer and other frame areas, which are outside of the guaranteed area
- As the light from backlight may leak from the gap at outside of active area, which are outside of active area, please pay attentions to such leakage when designing the set.
- The tolerances of the module width do not include warp of the case.
- FPC I/F Connector:FH26-51S-0,3SHW (05)

Fig.1 Outline Dimensions

(Appendix)

**Initial Code**

## Recommended Power on Initial Sequence

Step	Instruction/Parameters	Delay time	R/W	Reg. hex.	Data hex.	Description
1	Turn on VCI					VCI=2.8V
2	Turn on IOVCC					IOVCC=1.8V
3	Delay	10 ms				
4	REST pin high					
5	REST pin low	10 ms				
6	REST pin high					
7	Delay	200 ms				
8			W	FF00	0xAA	
9			W	FF01	0x55	
10			W	FF02	0x25	
11			W	FF03	0x01	
12			W	F300	0x00	
13			W	F301	0x32	
14			W	F302	0x00	
15			W	F303	0x38	
16			W	F304	0x31	
17			W	F305	0x08	
18			W	F306	0x11	
19			W	F307	0x00	
20			W	F000	0x55	
21			W	F001	0xAA	
22			W	F002	0x52	
23			W	F003	0x08	
24			W	F004	0x00	
25			W	B000	0x00	
26			W	B001	0x05	
27			W	B002	0x02	
28			W	B003	0x05	
29			W	B004	0x02	
30			W	B300	0x00	
31			W	B600	0x03	
32			W	B700	0x70	

Step	Instruction/Parameters	Delay time	R/W	Reg. hex.	Data hex.	Description
33			W	B701	0x70	
34			W	B800	0x00	
35			W	B801	0x06	
36			W	B802	0x06	
37			W	B805	0x06	
38			W	BC00	0x00	
39			W	BC01	0xc8	
40			W	BC02	0x00	
41			W	BD00	0x01	
42			W	BD01	0x84	
43			W	BD02	0x06	
44			W	BD03	0x50	
45			W	BD04	0x00	
46			W	cc00	0x03	
47			W	cc01	0x01	
48			W	cc02	0x06	
49			W	F000	0x55	
50			W	F001	0xAA	
51			W	F002	0x52	
52			W	F003	0x08	
53			W	F004	0x01	
54			W	B000	0x05	
55			W	B001	0x05	
56			W	B002	0x05	
57			W	B100	0x05	
58			W	B101	0x05	
59			W	B102	0x05	
60			W	B200	0x03	
61			W	B201	0x03	
62			W	B202	0x03	
63			W	B800	0x25	
64			W	B801	0x25	
65			W	B802	0x25	
66			W	B300	0x0b	
67			W	B301	0x0b	



Step	Instruction/Parameters	Delay time	R/W	Reg. hex.	Data hex.	Description
68			W	B302	0x0b	
69			W	B900	0x34	
70			W	B901	0x34	
71			W	B902	0x34	
72			W	BF00	0x01	
73			W	B500	0x08	
74			W	B501	0x08	
75			W	B502	0x08	
76			W	BA00	0x24	
77			W	BA01	0x24	
78			W	BA02	0x24	
79			W	B400	0x2D	
80			W	B401	0x2D	
81			W	B402	0x2D	
82			W	BC00	0x00	
83			W	BC01	0x68	
84			W	BC02	0x00	
85			W	BD00	0x00	
86			W	BD01	0x7C	
87			W	BD02	0x00	
88			W	BE00	0x00	
89			W	BE01	0x40	
90			W	F000	0x55	
91			W	F001	0xAA	
92			W	F002	0x52	
93			W	F003	0x01	
94			W	D000	0x0B	
95			W	D001	0x14	
96			W	D002	0x0C	
97			W	D003	0x0E	
98			W	D100	0x00	
99			W	D101	0x37	
100			W	D102	0x00	
101			W	D103	0x4A	
102			W	D104	0x00	

Step	Instruction/Parameters	Delay time	R/W	Reg. hex.	Data hex.	Description
103			W	D105	0x6F	
104			W	D106	0x00	
105			W	D107	0x8D	
106			W	D108	0x00	
107			W	D109	0xAD	
108			W	D10A	0x00	
109			W	D10B	0xDF	
110			W	D10C	0x01	
111			W	D10D	0x11	
112			W	D10E	0x01	
113			W	D10F	0x58	
114			W	D110	0x01	
115			W	D111	0x76	
116			W	D112	0x01	
117			W	D113	0xA6	
118			W	D114	0x01	
119			W	D115	0xCD	
120			W	D116	0x02	
121			W	D117	0x0E	
122			W	D118	0x02	
123			W	D119	0x46	
124			W	D11A	0x02	
125			W	D11B	0x48	
126			W	D11C	0x02	
127			W	D11D	0x78	
128			W	D11E	0x02	
129			W	D11F	0xAC	
130			W	D120	0x02	
131			W	D121	0xCD	
132			W	D122	0x02	
133			W	D123	0xFD	
134			W	D124	0x03	
135			W	D125	0x1F	
136			W	D126	0x03	
137			W	D127	0x4B	

Step	Instruction/Parameters	Delay time	R/W	Reg. hex.	Data hex.	Description
138			W	D128	0x03	
139			W	D129	0x69	
140			W	D12A	0x03	
141			W	D12B	0x8E	
142			W	D12C	0x03	
143			W	D12D	0xA5	
144			W	D12E	0x03	
145			W	D12F	0xCD	
146			W	D130	0x03	
147			W	D131	0xF1	
148			W	D132	0x03	
149			W	D133	0xF1	
150			W	D200	0x00	
151			W	D201	0x37	
152			W	D202	0x00	
153			W	D203	0x4A	
154			W	D204	0x00	
155			W	D205	0x6F	
156			W	D206	0x00	
157			W	D207	0x8D	
158			W	D208	0x00	
159			W	D209	0xAD	
160			W	D20A	0x00	
161			W	D20B	0xDF	
162			W	D20C	0x01	
163			W	D20D	0x11	
164			W	D20E	0x01	
165			W	D20F	0x58	
166			W	D210	0x01	
167			W	D211	0x76	
168			W	D212	0x01	
169			W	D213	0xA6	
170			W	D214	0x01	
171			W	D215	0xCD	
172			W	D216	0x02	

Step	Instruction/Parameters	Delay time	R/W	Reg. hex.	Data hex.	Description
173			W	D217	0x0E	
174			W	D218	0x02	
175			W	D219	0x46	
176			W	D21A	0x02	
177			W	D21B	0x48	
178			W	D21C	0x02	
179			W	D21D	0x78	
180			W	D21E	0x02	
181			W	D21F	0xAC	
182			W	D220	0x02	
183			W	D221	0xCD	
184			W	D222	0x02	
185			W	D223	0xFD	
186			W	D224	0x03	
187			W	D225	0x1F	
188			W	D226	0x03	
189			W	D227	0x4B	
190			W	D228	0x03	
191			W	D229	0x69	
192			W	D22A	0x03	
193			W	D22B	0x8E	
194			W	D22C	0x03	
195			W	D22D	0xA5	
196			W	D22E	0x03	
197			W	D22F	0xCD	
198			W	D230	0x03	
199			W	D231	0xF1	
200			W	D232	0x03	
201			W	D233	0xF1	
202			W	D300	0x00	
203			W	D301	0x37	
204			W	D302	0x00	
205			W	D303	0x4A	
206			W	D304	0x00	
207			W	D305	0x6F	

Step	Instruction/Parameters	Delay time	R/W	Reg. hex.	Data hex.	Description
208			W	D306	0x00	
209			W	D307	0x8D	
210			W	D308	0x00	
211			W	D309	0xAD	
212			W	D30A	0x00	
213			W	D30B	0xDF	
214			W	D30C	0x01	
215			W	D30D	0x11	
216			W	D30E	0x01	
217			W	D30F	0x58	
218			W	D310	0x01	
219			W	D311	0x76	
220			W	D312	0x01	
221			W	D313	0xA6	
222			W	D314	0x01	
223			W	D315	0xCD	
224			W	D316	0x02	
225			W	D317	0x0E	
226			W	D318	0x02	
227			W	D319	0x46	
228			W	D31A	0x02	
229			W	D31B	0x48	
230			W	D31C	0x02	
231			W	D31D	0x78	
232			W	D31E	0x02	
233			W	D31F	0xAC	
234			W	D320	0x02	
235			W	D321	0xCD	
236			W	D322	0x02	
237			W	D323	0xFD	
238			W	D324	0x03	
239			W	D325	0x1F	
240			W	D326	0x03	
241			W	D327	0x4B	
242			W	D328	0x03	

Step	Instruction/Parameters	Delay time	R/W	Reg. hex.	Data hex.	Description
243			W	D329	0x69	
244			W	D32A	0x03	
245			W	D32B	0x8E	
246			W	D32C	0x03	
247			W	D32D	0xA5	
248			W	D32E	0x03	
249			W	D32F	0xCD	
250			W	D330	0x03	
251			W	D331	0xF1	
252			W	D332	0x03	
253			W	D333	0xF1	
254			W	D400	0x00	
255			W	D401	0x37	
256			W	D402	0x00	
257			W	D403	0x4A	
258			W	D404	0x00	
259			W	D405	0x6F	
260			W	D406	0x00	
261			W	D407	0x8D	
262			W	D408	0x00	
263			W	D409	0xAD	
264			W	D40A	0x00	
265			W	D40B	0xDF	
266			W	D40C	0x01	
267			W	D40D	0x11	
268			W	D40E	0x01	
269			W	D40F	0x58	
270			W	D410	0x01	
271			W	D411	0x76	
272			W	D412	0x01	
273			W	D413	0xA6	
274			W	D414	0x01	
275			W	D415	0xCD	
276			W	D416	0x02	
277			W	D417	0x0E	

Step	Instruction/Parameters	Delay time	R/W	Reg. hex.	Data hex.	Description
278			W	D418	0x02	
279			W	D419	0x46	
280			W	D41A	0x02	
281			W	D41B	0x48	
282			W	D41C	0x02	
283			W	D41D	0x78	
284			W	D41E	0x02	
285			W	D41F	0xAC	
286			W	D420	0x02	
287			W	D421	0xCD	
288			W	D422	0x02	
289			W	D423	0xFD	
290			W	D424	0x03	
291			W	D425	0x1F	
292			W	D426	0x03	
293			W	D427	0x4B	
294			W	D428	0x03	
295			W	D429	0x69	
296			W	D42A	0x03	
297			W	D42B	0x8E	
298			W	D42C	0x03	
299			W	D42D	0xA5	
300			W	D42E	0x03	
301			W	D42F	0xCD	
302			W	D430	0x03	
303			W	D431	0xF1	
304			W	D432	0x03	
305			W	D433	0xF1	
306			W	D500	0x00	
307			W	D501	0x37	
308			W	D502	0x00	
309			W	D503	0x4A	
310			W	D504	0x00	
311			W	D505	0x6F	
312			W	D506	0x00	

Step	Instruction/Parameters	Delay time	R/W	Reg. hex.	Data hex.	Description
313			W	D507	0x8D	
314			W	D508	0x00	
315			W	D509	0xAD	
316			W	D50A	0x00	
317			W	D50B	0xDF	
318			W	D50C	0x01	
319			W	D50D	0x11	
320			W	D50E	0x01	
321			W	D50F	0x58	
322			W	D510	0x01	
323			W	D511	0x76	
324			W	D512	0x01	
325			W	D513	0xA6	
326			W	D514	0x01	
327			W	D515	0xCD	
328			W	D516	0x02	
329			W	D517	0x0E	
330			W	D518	0x02	
331			W	D519	0x46	
332			W	D51A	0x02	
333			W	D51B	0x48	
334			W	D51C	0x02	
335			W	D51D	0x78	
336			W	D51E	0x02	
337			W	D51F	0xAC	
338			W	D520	0x02	
339			W	D521	0xCD	
340			W	D522	0x02	
341			W	D523	0xFD	
342			W	D524	0x03	
343			W	D525	0x1F	
344			W	D526	0x03	
345			W	D527	0x4B	
346			W	D528	0x03	
347			W	D529	0x69	



Step	Instruction/Parameters	Delay time	R/W	Reg. hex.	Data hex.	Description
348			W	D52A	0x03	
349			W	D52B	0x8E	
350			W	D52C	0x03	
351			W	D52D	0xA5	
352			W	D52E	0x03	
353			W	D52F	0xCD	
354			W	D530	0x03	
355			W	D531	0xF1	
356			W	D532	0x03	
357			W	D533	0xF1	
358			W	D600	0x00	
359			W	D601	0x37	
360			W	D602	0x00	
361			W	D603	0x4A	
362			W	D604	0x00	
363			W	D605	0x6F	
364			W	D606	0x00	
365			W	D607	0x8D	
366			W	D608	0x00	
367			W	D609	0xAD	
368			W	D60A	0x00	
369			W	D60B	0xDF	
370			W	D60C	0x01	
371			W	D60D	0x11	
372			W	D60E	0x01	
373			W	D60F	0x58	
374			W	D610	0x01	
375			W	D611	0x76	
376			W	D612	0x01	
377			W	D613	0xA6	
378			W	D614	0x01	
379			W	D615	0xCD	
380			W	D616	0x02	
381			W	D617	0x0E	
382			W	D618	0x02	

Step	Instruction/Parameters	Delay time	R/W	Reg. hex.	Data hex.	Description
383			W	D619	0x46	
384			W	D61A	0x02	
385			W	D61B	0x48	
386			W	D61C	0x02	
387			W	D61D	0x78	
388			W	D61E	0x02	
389			W	D61F	0xAC	
390			W	D620	0x02	
391			W	D621	0xCD	
392			W	D622	0x02	
393			W	D623	0xFD	
394			W	D624	0x03	
395			W	D625	0x1F	
396			W	D626	0x03	
397			W	D627	0x4B	
398			W	D628	0x03	
399			W	D629	0x69	
400			W	D62A	0x03	
401			W	D62B	0x8E	
402			W	D62C	0x03	
403			W	D62D	0xA5	
404			W	D62E	0x03	
405			W	D62F	0xCD	
406			W	D630	0x03	
407			W	D631	0xF1	
408			W	D632	0x03	
409			W	D633	0xF1	
410			W	F000	0x55	
411			W	F001	0xAA	
412			W	F002	0x52	
413			W	F003	0x08	
414			W	F004	0x00	
415			W	B400	0x10	
416			W	3A00	0x77	
417			W	B101	0x00	
418	Sleep out		W	1100		
419	delay	100 ms				

420	Display on		W	2900		
421	delay	100 ms				

Recommended Display On Sequence						
Step	Instruction/Parameters	Delay time	R/W	Reg. hex.	Data hex.	Command
1	DISPON		W	2900		
2	delay	100 ms				
3	B/L power on					

Recommended Power Off Register Setting

Recommended Display Off Sequence						
Step	Instruction/Parameters	Delay time	R/W	Reg. hex.	Data hex.	Command
1	B/L power off					
2	delay	100ms				
3	DISPOFF		W	2800		

Recommended SLEEP Mode Sequence						
Step	Instruction/Parameters	Delay time	R/W	Reg. hex.	Data hex.	Command
1	DISPOFF		W	2800		
2	B/L pwer off					
3	delay	100ms				
4	SLP IN		W	1000		

Recommended SLEEP OUT Sequence						
Step	Instruction/Parameters	Delay time	R/W	Reg. hex.	Data hex.	Command
1	Sleep out		W	1100		
2	delay	120 ms				
3	Display on		W	2900		
4	delay	100 ms				
5	B/L pwer on					
6						

Recommended DSTB Sequence						
Step	Instruction/Parameters	Delay time	R/W	Reg. hex.	Data hex.	Command
1	DISPOFF		W	2800		
2	SLP IN		W	1100		
3	Dealy	10 ms				
4	DSTB		W	4F00	01	
5						

Recommended DSTB WakeUp Sequence						
Step	Instruction/Parameters	Delay time	R/W	Reg. hex.	Data hex.	Command
1	REST pin high					
2	REST pin low	10 ms				
3	REST pin high					
4	Delay	200 ms				
5	Power on Initial Sequence					
6						

## Notes:

1. Undefined commands are treated as NOP (00h) command.
2. C=command, W=write, R=read, +=number of following parameters, (in Bytes), d=dummy clock cycle.