

PREPARED BY: DATE	SHARP	SPEC No. LCY-W-09902	
APPROVED BY: DATE		FILE No.	
To		LIQUID CRYSTAL DISPLAY GROUP SHARP CORPORATION	ISSUE: Sep 2, 2009
		SPECIFICATION	PAGE : 23 pages
		APPLICABLE GROUP MOBILE LCD CHINA DESIGN CENTER WUXI SHARP	

DEVICE SPECIFICATION FOR

TFT-LCD module

MODEL No. **LQ043T3DX04K**

CUSTOMER'S APPROVAL

DATE _____

BY _____

PRESENTED

BY *H. Watatani*

H. WATATANI

GENERAL MANAGER
MOBILE LCD CHINA DESIGN CENTER
WUXI SHARP

- This specification includes information and/or data that are subjected to Sharp's copyrights. Please see to it that this specification be handled with utmost care. No part may be copied without our permission.

- The examples of applications given herein are only intended for explaining typical applications of our product. Moreover, presenting this specification does not mean giving our warranty or licensing any industrial property rights or other rights. Besides, Sharp will not hold itself responsible for any issue that may arise with a third party on industrial property rights from or with regard to use of the product.

- This product has been developed and manufactured for applications to mobile instrument products.

- If this product is to be used for any other systems that require high reliability and safety in performance, accuracy, etc, such as transportation systems (aircrafts, trains, mobiles), security or fire-prevention systems, any other safety devices, etc, you are requested to allow for safety design of the entire system or device, such as fail-safe and redundancy design so as to maintain and assure its reliability and safety.

- Do not apply this product for aerospace systems, mainline communication systems, nuclear power control systems or medical equipment involved in life support that require high reliability and safety, as it is not intended for such use or application.

- Sharp shall not be liable for or indemnify any loss or damage that may arise from use or application of the product without observing our cautions, conditions, etc. as stated in this technical document.

- If there is anything unclear to you regarding the product, please contact our staff in charge of sales.

Contents

1. Applicable Scope 5

2. General Description 5

3. Mechanical (Physical) Specifications 5

4. Input Terminal Names and Functions 6

5. Absolute Maximum Ratings 7

6. Electrical Characteristics 8

7. Timing Characteristics of Input Signal 12

8. Input Signal and Display Color 15

9. Optical Characteristics 16

10. Handling of Modules 18

11. Delivery form 19

12. Reliability Test Conditions 20

13. Display Grade 20

14. Lot Number Marking 21

15. Others 21

16. Outline dimension 22

17. Packing style 23

1. Applicable Scope

This specification is applicable to TFT-LCD Module “LQ043T3DX04K” only.

2. General Description

This module is a color active matrix LCD module incorporating amorphous silicon TFT(Thin Film Transistor) It is composed of a color TFT-LCD panel, driver ICs, Input FPC and a back light unit. Graphics and texts can be displayed on a 480×3×272 dots panel with about 16million colors by supplying 24bit data signals (8bit×RGB), Four timing signals, logic (typ. +2.5V), analog (typ. +5V) supply voltages for TFT-LCD panel driving and supply voltage for back light.

3. Mechanical (Physical) Specifications

Item	Specifications	Unit
Screen size	10.9 (4.3" type) diagonal	cm
Active area	95.04(H)×53.856(V)	mm
Pixel format	480×272	pixel
	1Pixel =R+G+B dots	
Pixel pitch	0.198(H)×0.198(V)	mm
Pixel configuration	R,G,B vertical stripes	
Display mode	Normally black	
Unit outline dimensions	105.5(W)×67.2(H)×3.95(D)	mm
Mass	50	g
Polarizer · Surface treatment	Clear hard coat	

※ The above-mentioned table indicates module sizes without some projections and FPC.

4. Input Terminal Names and Functions

4-1. TFT LCD Panel Driving (Reference Connector : Hirose Electric CO., LTD.Product No.: FH12A-40S-0.5SH(55) Top contact type)

The Bottom contact type can be selected according to side of mounted connector and terminal side of FPC.

※ Please adopt the gold plated terminal.

Terminal No.	Terminal name	Function	Remarks
1	GND	GND(0V)	
2	GND	GND(0V)	
3	VCC	+2.5V power source	
4	VCC	+2.5V power source	
5	R0	RED Data Signal (LSB)	
6	R1	RED Data Signal	
7	R2	RED Data Signal	
8	R3	RED Data Signal	
9	R4	RED Data Signal	
10	R5	RED Data Signal	
11	R6	RED Data Signal	
12	R7	RED Data Signal (MSB)	
13	G0	GREEN Data Signal (LSB)	
14	G1	GREEN Data Signal	
15	G2	GREEN Data Signal	
16	G3	GREEN Data Signal	
17	G4	GREEN Data Signal	
18	G5	GREEN Data Signal	
19	G6	GREEN Data Signal	
20	G7	GREEN Data Signal (MSB)	
21	B0	BLUE Data Signal (LSB)	
22	B1	BLUE Data Signal	
23	B2	BLUE Data Signal	
24	B3	BLUE Data Signal	
25	B4	BLUE Data Signal	
26	B5	BLUE Data Signal	
27	B6	BLUE Data Signal	
28	B7	BLUE Data Signal (MSB)	
29	GND	GND(0V)	
30	CK	Clock signal to sample each data	
31	DISP	Display ON/OFF Signal	
32	Hsync	Horizontal synchronizing signal	
33	Vsync	Vertical synchronizing signal	
34	NC	NC	Note 1
35	AVDD	+5V Analog power source	
36	AVDD	+5V Analog power source	
37	NC	NC	Note 1
38	TEST1	TEST1	Note 2
39	TEST2	TEST2	Note 3
40	TEST3	TEST3	Note 3

Note 1) They have been open within FPC.

Note 2) Please be sure to set 38 pins (TEST1) to open.

Note 3) Please be sure to connect 39 pin (TEST2) ,40 pin (TEST3) with GND.

4-2. Backlight

0.5mmP 4Pin FPC (Reference Connector :Kyocera Elco Corporation Product No. : 6298 Bottom contact type)

- ※ The top and bottom contact type can be selected according to side of mounted connector and terminal side of FPC.
- ※ Please adopt the gold plated terminal.

Terminal No.	Signal	Function
1	V _{LED-}	LED Power Source Input terminal (Cathode side)
2	NC	No Connection
3	NC	No Connection
4	V _{LED+}	LED Power Source Input terminal (Anode side)

5. Absolute Maximum Ratings

Item	Symbol	Conditions	Rated value	Unit	Remarks
Input voltage	V _I	Ta=25°C	-0.3 ~ VCC+0.3	V	【Note 1】
2.5 V Power supply voltage	VCC	Ta=25°C	0 ~ +4.5	V	
5 V Power supply voltage	AVDD	Ta=25°C	0 ~ +6.0	V	
Temperature for storage	T _{stg}	—	-30 ~ +70	°C	【Note 2】
Temperature for operation	T _{opa}	—	-20 ~ +60	°C	【Note 3】
LED Input electric current	I _{LED}	Ta=25°C	35	mA	【Note 4】
LED electricity consumption	P _{LED}	Ta=25°C	123	mW	【Note 5】

【Note 1】 CK,R0~R7,G0~G7,B0~B7,Hsync,Vsync,DISP

【Note 2】 Humidity : 80%RHMax. (Ta≤40°C)

Maximum bulb temperature under 39°C (Ta>40°C) See to it that no dew will be condensed.

【Note 3】 Panel surface temperature prescribes.

(Reliability is examined at ambient temperature of 60°C.)

【Note 4】 Input curret of one LED (Ta=25°C) (use LED NSSW008C 7pieces)

【Note 5】 Power consumption of one LED (Ta=25°C) (use LED NSSW008C 7pieces)

6. Electrical Characteristics

6-1. TFT LCD Panel Driving

Ta = 25°C

Item		Symbol	Min.	Typ.	Max.	Unit	Remarks
+2.5V power supply	DC voltage	VCC	+2.3	+2.5	+3.3	V	【Note 1, 6】
	DC Current	ICC		1.2	3	mA	【Note 3】
+5V power supply	DC voltage	AVDD	+4.8	+5.0	+5.2	V	【Note 1, 6】
	DC Current	I _{AVDD}		10	18	mA	【Note 3】
Permissive Input ripple voltage		V _{RFVCC}			100	mVp-p	V _{CC} =+2.5V
		V _{RFAVDD}			100	mVp-p	V _{CC} =+5.0V
Input voltage (Low)		V _{IL}			0.2 V _{CC}	V	【Note 4】
Input voltage (High)		V _{IH}	0.8 V _{CC}			V	
Input current (Low)		I _{OL}			4.0	μA	V _I =0V 【Note 4】
Input current (High)		I _{OH}			4.0	μA	V _I =2.5V 【Note 4】

※ The rush current will flows when power supply is turned on, so please design the power supply circuit referring to 【Note 5】
(The rush current changes according to the condition of the supply voltage value, rising time and so on.)

[Note 1]

Sequences of supply voltage and signals

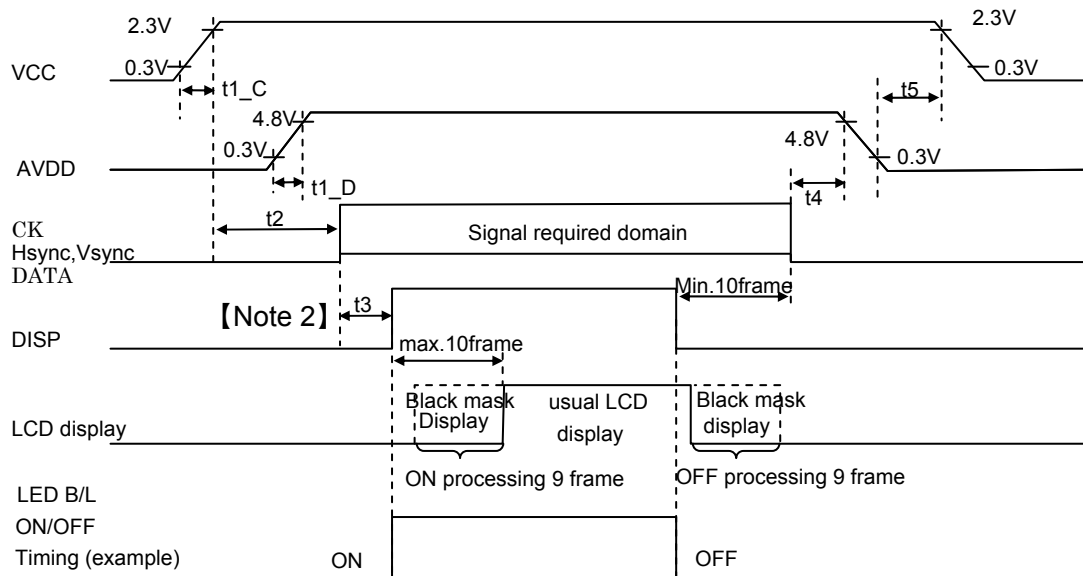

- ⊙ Please do not supply AVDD before VCC.
- ⊙ It discharges and boost up voltage for TFT module on the basis of a DISP-signal
It drives Max-10 flames (about 0.2seconds) from change of DISP-signals by reasons that It takes time for 9 flames while each processing operation.
Therefore, the display start is delayed for 10 flames and Ten or more frames needs to be voltage maintained at the time of a display end.
Please do not change the DISP-signal level for 10 frames or less after the change.
- ⊙ It is not problem to set up DISP=L , AVDD=GND when VCC voltage is supplied
- ⊙ Please don't set various signals to Hi-Z when VCC-voltage is supplied in reason that those signals are CMOS input.
- ⊙ Don't change DISP signal into the state of H level When AVDD voltage is in the state of GND.
- ⊙ The ON/OFF timing of LED Back Light is an example.

	MIN	TYP	MAX	unit	Remarks
t1_C	0	—	10	ms	
t1_D	0.5	—	10	ms	
t2	50	—	—	ms	
t3	0.5	—	—	ms	[Note 2]
t4	0	—	—	ms	
t5	0	—	—	ms	

Dip Conditions for supply voltage

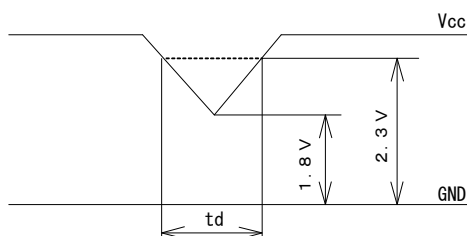

$t_d \leq 10ms$

【Note 2】 While “VSYNC” is “Low”, don’t change “DISP” signal “Low” to “High”.

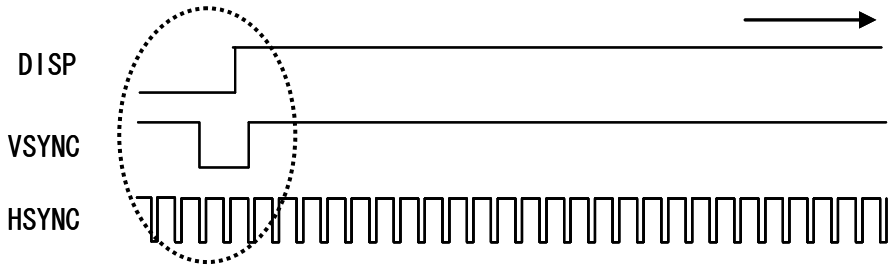

【 Allowed Timing 】

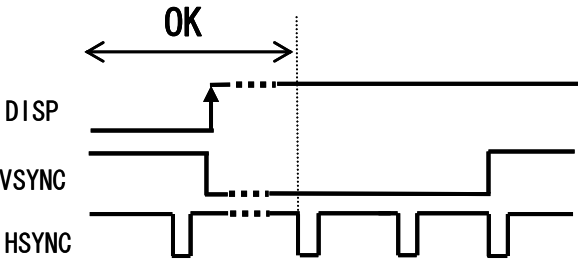

【 Prohibited Timing 】

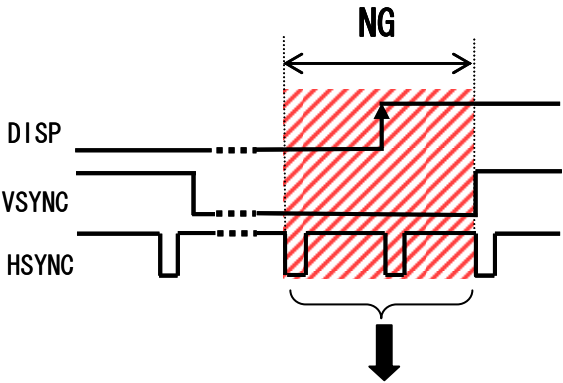

2x HSYNC period right before
“VSYNC” changes from “Low” to ”High” .

【Note 3】 Typical current situation: 256-gray-bar pattern VCC=2.5V AVDD=5.0V

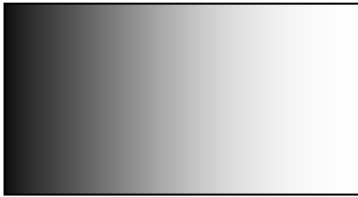

【Note 4】 CK, R0~R7, G0~G7,B0~B7,Hsync,Vsync,DISP

【 Note 5 】

An example of rush current measurement

◎Measurement conditions

- Power supply voltage VCC : 2.5V AVDD : 5.0V
- Disp signal : OFF ⇒ ON
- Other input signals : GND
- Measurement system : refer to right Fig.
- rush current measurement timing : refer to following Fig.

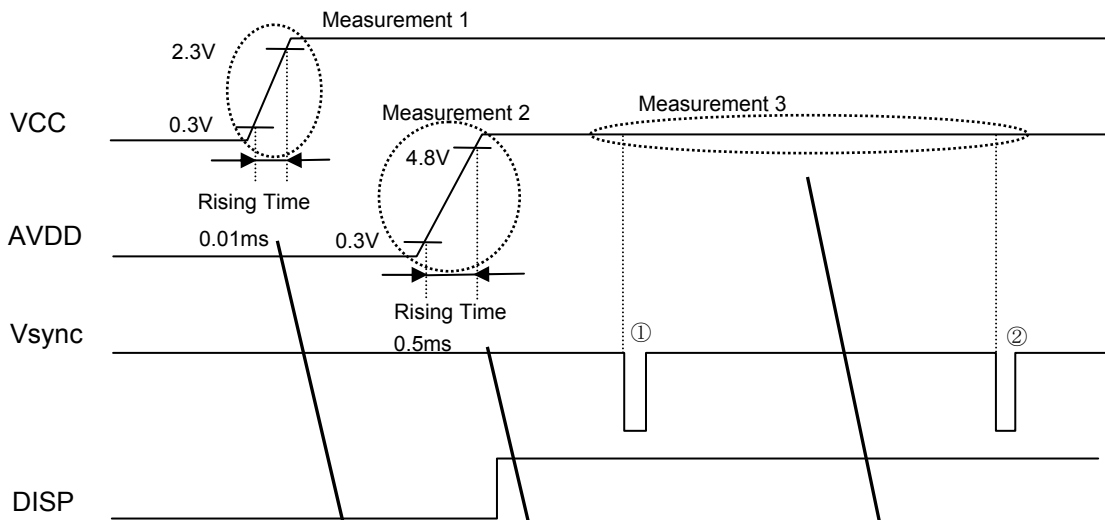
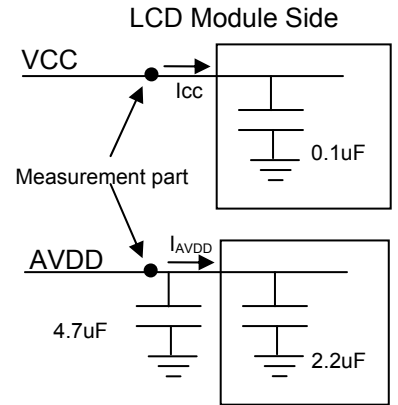

◎Measurement Example

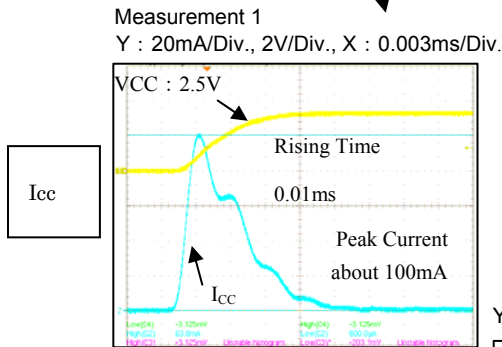

I_{AVDD}

Measurement 2 Y : 20mA/Div., 2V/Div., X : 0.08ms/Div. Measurement 3 Y : 50mA/Div., 5V/Div., X : 4ms/Div.

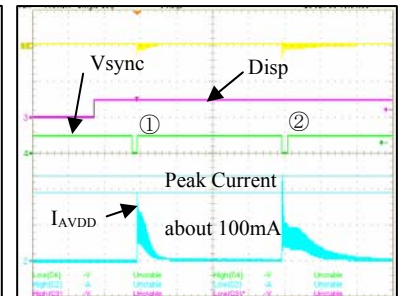
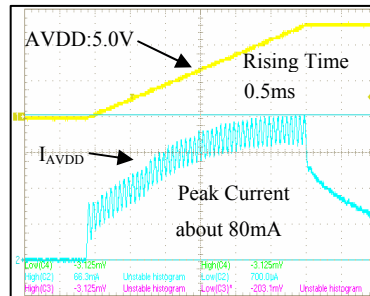

These rush current won't flow stationary, these will flow at the timing shown in Measurement 3.

【 Note 6 】 Please input the voltage between the maximum values and minimum value in the table.

(Example: Vcc;+3.3V±5% is not allowable.)

6-2. Back light driving

The back light system has seven LEDs
[NSSW008C]

Parameter	Symbol	Min.	Typ.	Max.	Unit	Remark
Rated Voltage	V_{BL}	—	24.5	25.8	V	Ta=25°C 【Note 1】
Rated Current	I_L	—	18	28	mA	Ta=25°C 【Note 2】

【Note 1】 $V_{BL}(Typ)$ is the maximum voltage when $I_{LED} = 18mA$, $V_{BL}(Max)$ is the maximum voltage when $I_{LED} = 28mA$.

【Note 2】 Ambient temperature and the maximum input(Forward current I_{LED} in a figure) satisfy the following terms of use.

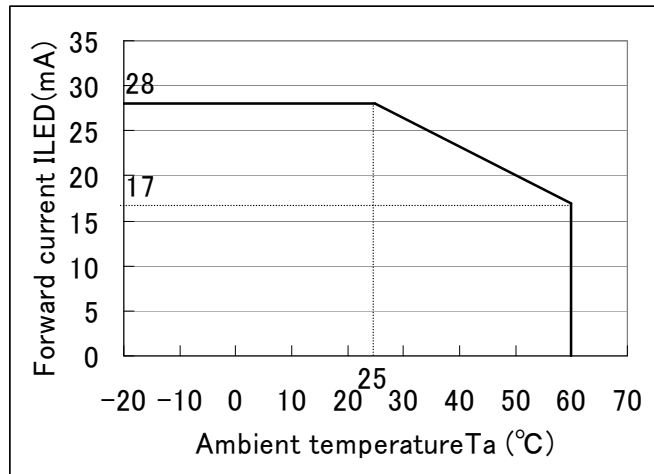

Ambient temperature and the maximum input

7. Timing characteristics of input signals

An input signal timing waveform is shown in Fig. 2.

7-1 Timing characteristics

Parameter		Symbol	Min.	Typ.	Max.	Unit	Remark
Clock	Frequency	1/Tc	7.83	9.00	9.26	MHz	
	Duty ratio	Th/T	40	50	60	%	
Data	Set up time	Tds	25	—	—	ns	
	Hold time	Tdh	25	—	—	ns	
Horizontal synchronizing	Period	TH	—	525	—	Clock	
	Pulse width	THp	—	41	—	Clock	
	Horizontal	THd	480	480	480	Clock	
	Back porch	THb	2	2	2	Clock	
	Front porch	THf	2	2	—	Clock	
	Set up time	THs	25	—	—	ns	
Vertical synchronizing	Period	TV	—	286	—	Line	
	Pulse width	TVp	2	10	—	Line	
	Vertical	TVd	272	272	272	Line	
	Back porch	TVb	2	2	2	Line	
	Front porch	TVf	2	2	—	Line	
	Set up time	TVs	25	—	—	ns	

【Note】 • In case of using the slow frequency, the deterioration of display, flicker etc may occur.
• The timing characteristics are basically fixed as above.

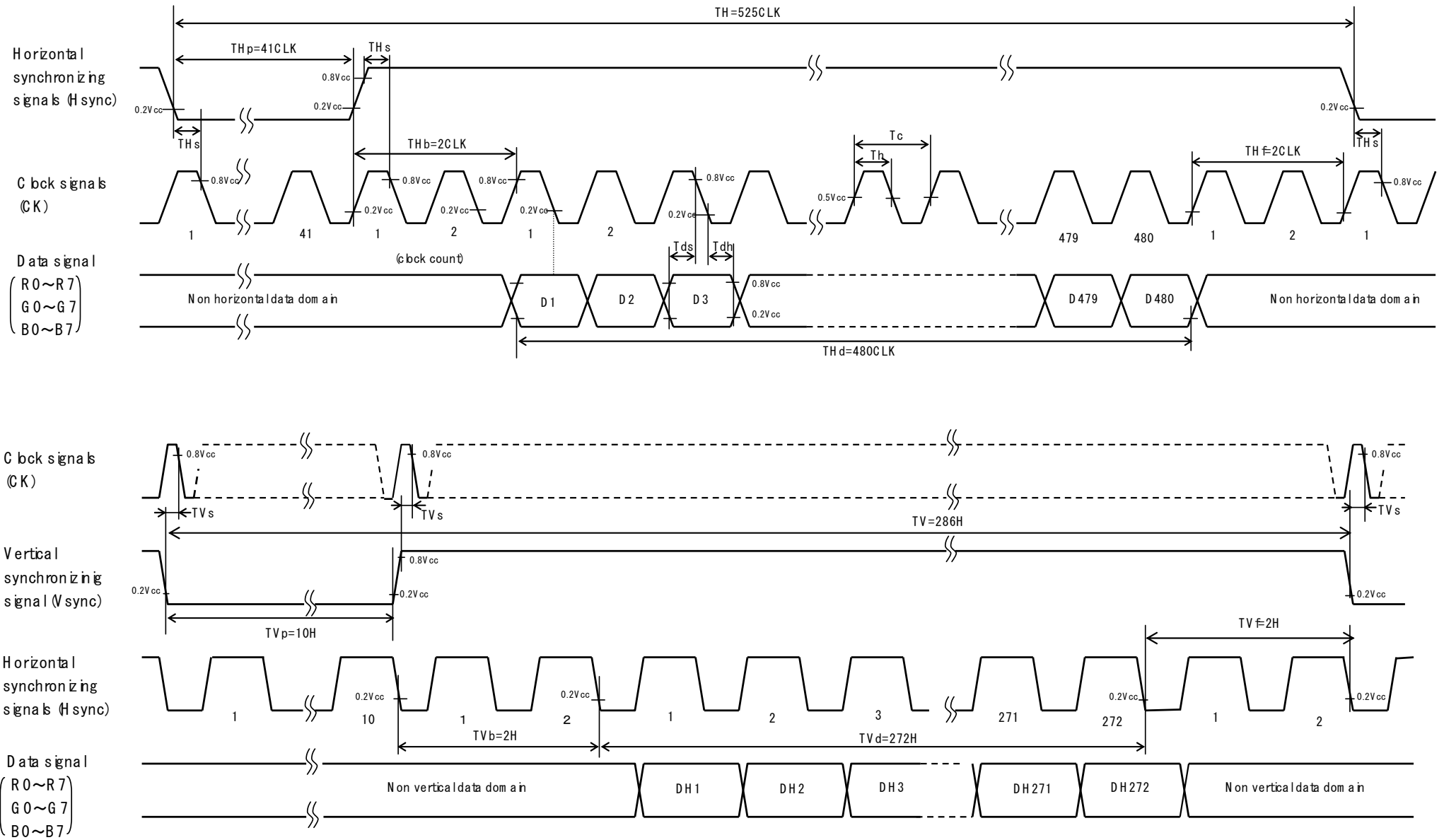
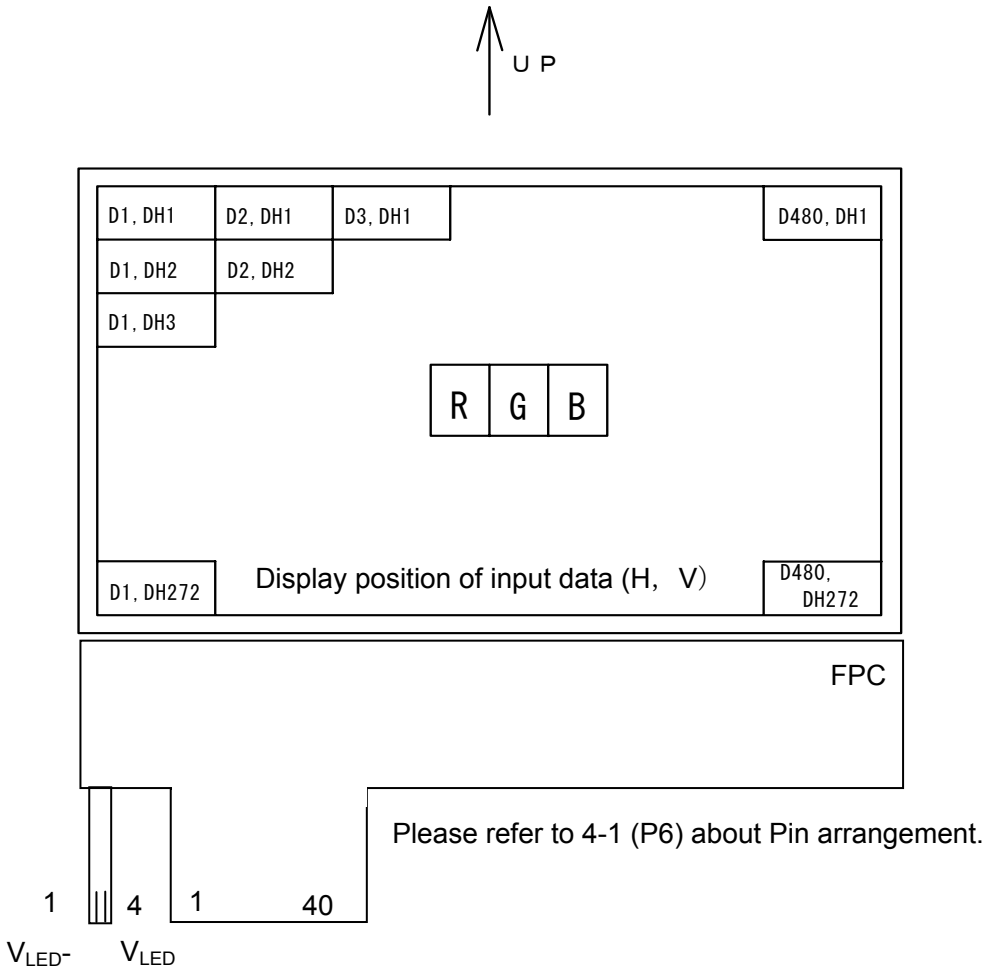

Fig 2 Input signal timing

7-3 Input Data Signals and Display Position on the screen



Please refer to 4-2 about LED side Pin arrangement.

8. Input Signals, Basic Display Colors and Gray Scale of Each Color

	Colors & Gray Scale	Data signal																											
		Gray Scale	R0	R1	R2	R3	R4	R5	R6	R7	G0	G1	G2	G3	G4	G5	G6	G7	B0	B1	B2	B3	B4	B5	B6	B7			
		LSB	MSB							LSB	MSB							LSB	MSB										
Basic Color	Black	—	0	0	0	0	0	0	0	0	0	0	0	0	0	0	0	0	0	0	0	0	0	0	0	0	0		
	Blue	—	0	0	0	0	0	0	0	0	0	0	0	0	0	0	0	0	1	1	1	1	1	1	1	1	1		
	Green	—	0	0	0	0	0	0	0	0	1	1	1	1	1	1	1	1	0	0	0	0	0	0	0	0	0		
	Cyan	—	0	0	0	0	0	0	0	0	1	1	1	1	1	1	1	1	1	1	1	1	1	1	1	1	1		
	Red	—	1	1	1	1	1	1	1	1	0	0	0	0	0	0	0	0	0	0	0	0	0	0	0	0	0		
	Magenta	—	1	1	1	1	1	1	1	1	0	0	0	0	0	0	0	0	1	1	1	1	1	1	1	1	1		
	Yellow	—	1	1	1	1	1	1	1	1	1	1	1	1	1	1	1	1	0	0	0	0	0	0	0	0	0		
	White	—	1	1	1	1	1	1	1	1	1	1	1	1	1	1	1	1	1	1	1	1	1	1	1	1	1		
Gray Scale of Red	Black	GS0	0	0	0	0	0	0	0	0	0	0	0	0	0	0	0	0	0	0	0	0	0	0	0	0	0		
	↑	GS1	1	0	0	0	0	0	0	0	0	0	0	0	0	0	0	0	0	0	0	0	0	0	0	0	0		
	Darker	GS2	0	1	0	0	0	0	0	0	0	0	0	0	0	0	0	0	0	0	0	0	0	0	0	0	0		
	↑	↓	↓							↓							↓												
	↓	↓	↓							↓							↓												
	Brighter	GS253	1	0	1	1	1	1	1	1	0	0	0	0	0	0	0	0	0	0	0	0	0	0	0	0	0		
	↓	GS254	0	1	1	1	1	1	1	1	0	0	0	0	0	0	0	0	0	0	0	0	0	0	0	0	0		
	Red	GS255	1	1	1	1	1	1	1	1	0	0	0	0	0	0	0	0	0	0	0	0	0	0	0	0	0		
Gray Scale of Green	Black	GS0	0	0	0	0	0	0	0	0	0	0	0	0	0	0	0	0	0	0	0	0	0	0	0	0	0		
	↑	GS1	0	0	0	0	0	0	0	0	1	0	0	0	0	0	0	0	0	0	0	0	0	0	0	0	0		
	Darker	GS2	0	0	0	0	0	0	0	0	0	1	0	0	0	0	0	0	0	0	0	0	0	0	0	0	0		
	↑	↓	↓							↓							↓												
	↓	↓	↓							↓							↓												
	Brighter	GS253	0	0	0	0	0	0	0	0	1	0	1	1	1	1	1	1	0	0	0	0	0	0	0	0	0		
	↓	GS254	0	0	0	0	0	0	0	0	0	1	1	1	1	1	1	1	0	0	0	0	0	0	0	0	0		
	Green	GS255	0	0	0	0	0	0	0	0	1	1	1	1	1	1	1	1	0	0	0	0	0	0	0	0	0		
Gray Scale Blue	Black	GS0	0	0	0	0	0	0	0	0	0	0	0	0	0	0	0	0	0	0	0	0	0	0	0	0	0		
	↑	GS1	0	0	0	0	0	0	0	0	0	0	0	0	0	0	0	0	1	0	0	0	0	0	0	0	0		
	Darker	GS2	0	0	0	0	0	0	0	0	0	0	0	0	0	0	0	0	0	1	0	0	0	0	0	0	0		
	↑	↓	↓							↓							↓												
	↓	↓	↓							↓							↓												
	Brighter	GS253	0	0	0	0	0	0	0	0	0	0	0	0	0	0	0	0	1	0	1	1	1	1	1	1	1		
	↓	GS254	0	0	0	0	0	0	0	0	0	0	0	0	0	0	0	0	0	1	1	1	1	1	1	1	1		
	Blue	GS255	0	0	0	0	0	0	0	0	0	0	0	0	0	0	0	0	1	1	1	1	1	1	1	1	1		

0 : Low level voltage 1 : High level voltage

Each basic color can be displayed in 256 gray scales from 8 bit data signals. According to the combination of 24 bit data signals, the 16-million-color display can be achieved on the screen.

9. Optical Characteristics

Module characteristics

Ta = 25°C, VCC = +2.5V, AVDD = 5.0V

Parameter	Symbol	Condition	Min.	Typ.	Max.	Unit	Remark	
Viewing angle range	Horizontal	CR > 10	—	80	—	Deg.	【Note1,4】	
	Vertical		θ11	—	80	—		Deg.
			θ12	—	80	—		Deg.
Contrast ratio	CR	θ=0°	100	400	—		【Note2,4】	
Response Time	Rise	θ=0°	—	30	45	ms	【Note3,4】	
	Decay		—	30	45	ms		
Chromaticity of White	x		0.259	0.309	0.359		【Note4】	
	y		0.297	0.347	0.397			
Luminance of white	XL1		—	230	—	cd/m ²	ILED=18mA 【Note4】	
			—	320	—		ILED=28mA 【Note4】	

※ The optical characteristics measurements are operated under a stable luminescence (I_{LED} = 18mA) and a dark condition. (refer to Fig.3)

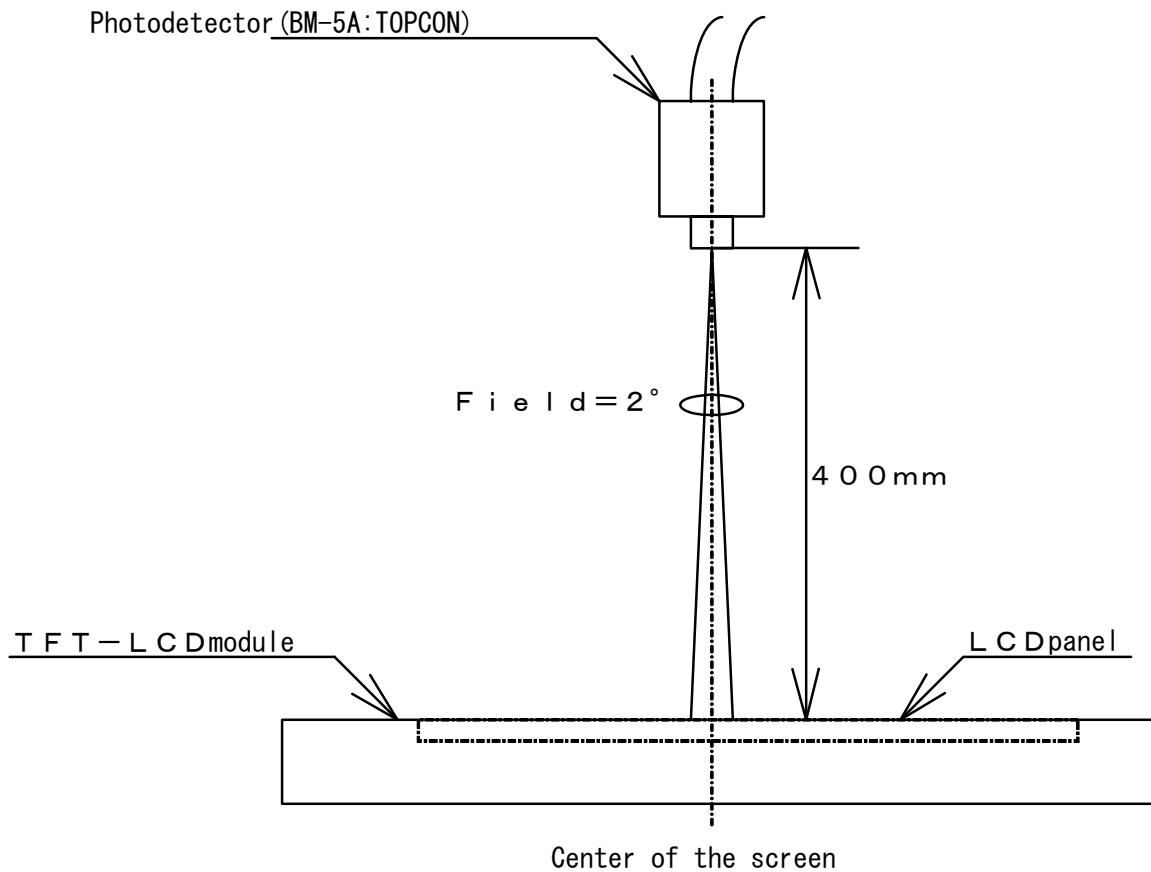
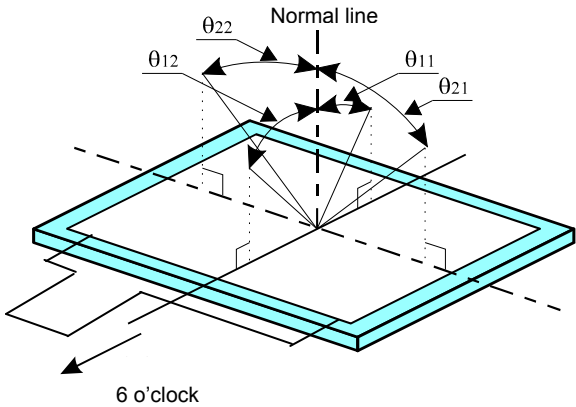

Fig. 3 Optical characteristics measurement method

【 Note 1 】 Definitions of viewing angle range



【 Note 2 】 Definition of contrast ratio

The contrast ratio is defined as the following

$$\text{Contrast ratio(CR)} = \frac{\text{Luminance (brightness) with all pixels white}}{\text{Luminance (brightness) with all pixels black}}$$

【 Note 3 】 Definition of response time

The response time is defined as the following figure and shall be measured by switching the input signal for “black” and “white”

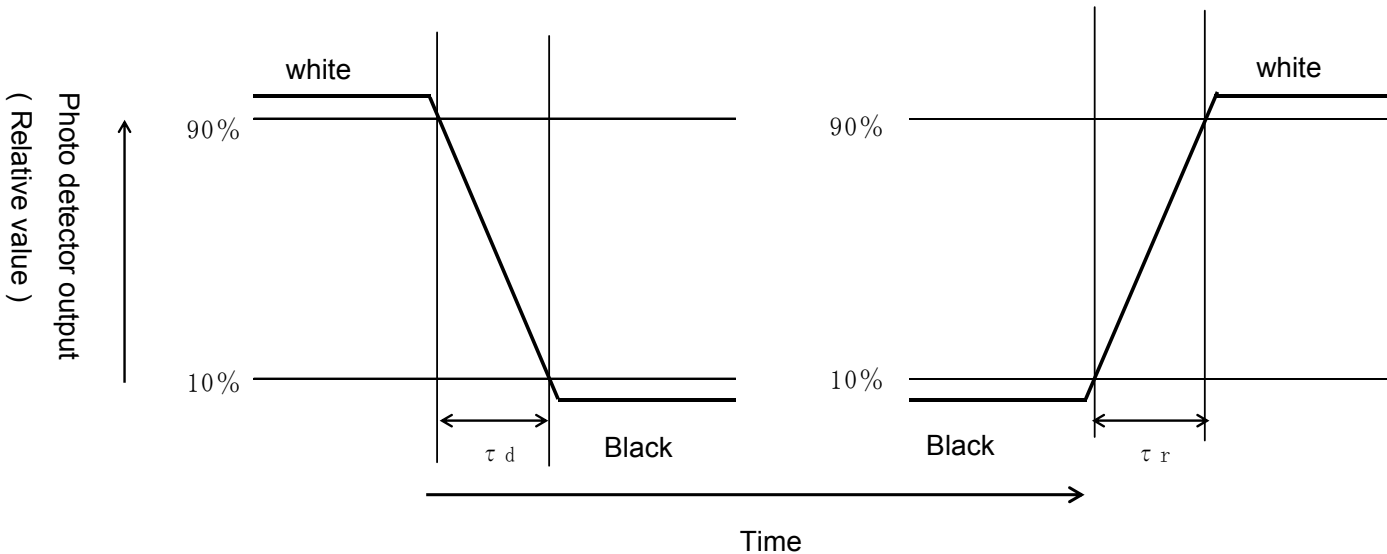

【 Note 4 】 This shall be measured at center of the screen.

10. Handling of modules

10-1 Inserting the FPC into its connector and pulling it out.

- ① Be sure to turn off the power supply and the signals when inserting or disconnecting the cable.
- ② Please insert for too much stress not to join FPC in the case of insertion of FPC.

10-2 About handling of FPC

- ① The bending radius of the FPC should be more than 1.4mm, and it should be bent evenly.
- ② Do not dangle the LCD module by holding the FPC, or do not give any stress to it.
- ③ The direction of the bend of FPC is only a direction of the module back. Please do not bend FPC in the direction of the module surface.

10-3 Mounting of the module

- ① The module should be held on to the plain surface. Do not give any warping or twisting stress to the module.
- ② Please consider that GND can ground a modular metal portion etc. so that static electricity is not charged to a module.

10-4 Cautions in assembly / Handling pre cautions.

As the polarizer can be easily scratched, be most careful in handling it.

- ① Work environments in assembly.

Working under the following environments is desirable:

- a) Implement more than $1M\Omega$ conductive treatment (by placing a conductive mat or applying Conductive paint) on the floor or tiles.
 - b) No dusts come in to the working room. Place an adhesive, anti-dust mat at the entrance of the room.
 - c) Humidity of 50~70% and temperature of 15~27°C are desirable.
 - d) All workers wear conductive shoes, conductive clothes, conductive fingerstalls and grounding belts without fail.
 - e) Use a blower for electrostatic removal. Set it in a direction slightly tilt downward so that each Module can be well subjected to its wind. Set the blower at an optimum distance between the blower and the module.
- ② How the remove dust on the polarizer
 - a) Blow out dust by the use of an N2 blower with antistatic measures taken. Use of an ionized air Gun is recommendable.
 - b) When the panel surface is soiled, wipe it with soft cloth.
 - ③ In the case of the module's metal part (shield case) is stained, wipe it with a piece of dry, soft cloth. If rather difficult, give a breath on the metal part to clean better.
 - ④ If a water dropped, etc. remains stuck on the polarizer for a long time, it is apt to get discolored or cause stains. Wipe it immediately.
 - ⑤ As a glass substrate is used for the TFT-LCD panel, if it is dropped on the floor or hit by something hard, it may be broken or chipped off.
 - ⑥ Since CMOS LSI is used in this module, take care of static electricity and take the human earth into consideration when handling.

10-5 Others

- ① Regarding storage of LCD modules, avoid storing them at direct sunlight-situation.

You are requested to store under the following conditions:

(Environmental conditions of temperature/humidity for storage)

- (1) Temperature: 0~40°C

- (2) Relative humidity : 95% or less

- As average values of environments (temperature and humidity) for storing, use the following control guidelines:

Summer season: 20~35°C, 85% or less Winter season: 5~15°C, 85% or less

- If stored under the conditions of 40°C and 95% RH, cumulative time of storage must be less than 240 hours.

- ① If stored at temperatures below the rated values, the inner liquid crystal may freeze, causing cell destruction. At temperatures exceeding the rated values for storage, the liquid crystal may become isotropic liquid, making it no longer possible to come back to its original state in some cases.
- ② If the LCD is broken, do not drink liquid crystal in the mouth. If the liquid crystal adheres to a hand or foot or to clothes, immediately cleanse it with soap.
- ③ If a water drop or dust adheres to the polarizer, it is apt to cause deterioration. Wipe it immediately.
- ④ Be sure to observe other caution items for ordinary electronic parts and components.
- ⑤ Epoxy resin (amine series curing agent), silicone adhesive material (dealcoholization series and oxime series), tray forming agent (azo compound) etc, in the cabinet or the packing materials may induce abnormal display with polarizer film deterioration regardless of contact or noncontact to polarizer film. Be sure to confirm the component of them.

11. Delivery Form

11-1 . Carton storage conditions

- 1) Carton piling-up: Max 8 rows

- 2) Environments

Temperature: 0~40°C

Humidity: 65% RH or less (at 40°C)

There should be no dew condensation even at a low temperature and high humidity.

- 3)Packing form : As shown in Figure 4.

※Cartons are weak against damp, and they are apt to be smashed easily due to the compressive pressure applied when piled up. The above environmental conditions of temperature and humidity are set in consideration of reasonable pile-up for storage.

11-2. Packing composition

Name	quantity	Note
Carton size	1	575×360×225 (mm)
Tray (The number of Module)	12	Material : Electrification prevention polypropylene 8 unit / tray : 80unit/carton
Electrification prevention bag	2	Material : Electrification prevention polyethylene 680mm(length)×500mm(depth)×50μm(thin)

Carton weight (80unit):8kg

12. Reliability test items

No.	Test item	Conditions
1	High temperature storage test	Ta = 70°C 240h
2	Low temperature storage test	Ta = -30°C 240h
3	High temperature & high humidity operation test	Ta = 40°C ; 95%RH 240h (No condensation)
4	High temperature operation test	Ta = 60°C 240h (The panel temp. must be less than 60°C)
5	Low temperature operation test	Ta = -20°C 240h
6	Vibration test (non- operating)	Frequency : 10~55Hz/Vibration width (one side) : 1.5mm Sweep time : 1minutes Test period : (2 hours for each direction of X,Y,Z)
7	Shock test	Direction : ±X, ±Y, ±Z, Time : Third for each direction. Impact value : 100G Action time 6ms
8	Thermal shock test	Ta=-30°C~70°C /10 cycles (30 min) (30min)

【Result Evaluation Criteria】

Under the display quality test conditions with normal operation state, these shall be no change which may affect practical display function.

13. Display Grade

The standard regarding the grade of color LCD displaying modules should be based on the delivery inspection standard

14. Lot No. marking

The lot No. will be indicated on individual labels. The location is as shown

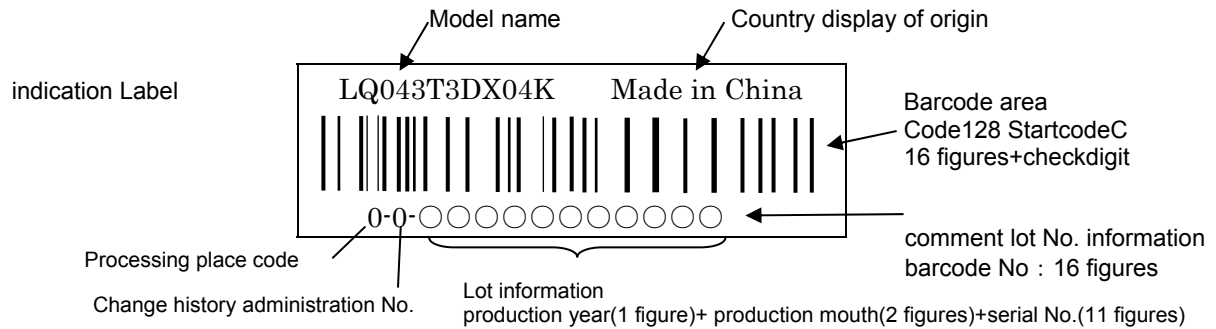

outward form : width $29.0 \pm 0.5\text{mm}$ length $11.5 \pm 0.5\text{mm}$

comment column :

- 1 figure Processing place code 「0」 WSEC Wuxi Factory
「1」 WSEC Lianyungang Factory
- 2 figure Change history administration No. 「0」
- 3 figure Production year
- 4, 5figure Production month
- 6 -16figures Serial No.

15. Others

- 1 Disassembling the module can cause permanent damage and you should be strictly avoided.
- 2 Please be careful that you don't keep the screen displayed fixed pattern image for a long time, since retention may occur.
- 3 If you pressed down a liquid crystal display screen with your finger and so on, the alignment disorder of liquid crystal will occur. And then It will become display fault.
Therefore, Be careful not to touch the screen directly, and to consider not stressing to it.
- 4 If any problem arises regarding the items mentioned in this specification sheet or otherwise, it should be discussed and settled mutually in a good faith for remedy and/or improvement.

【How to store the LCD modules in the package trays】

1. Clear the package trays and the modules of dust and remove static electricity from them with the static eliminator.
 2. Place the LCD modules with the screen side facing upward and arrange 8 of them in 2 horizontal lines and 4 vertical lines on a package tray so that the FPC parts on the modules come alternately.*1
 3. Make sure that the LCD modules are placed in each storage space of the package tray.
(Check especially whether the LCD modules are not left loose on the tray and whether they are not placed in reverse.)
 4. Pile 5 package trays with the LCD modules placed right and put an empty package tray on top of the piles.
(Pile the package trays with the round corner joined with each other, and do not pile up the package trays in reverse)
- *1 Start placing the module in the space closest to the round corner of the package tray as a datum. Continue placing the next one to the right until 4 of them are completely placed horizontally. And then arrange the other 4 of them from the right to the left on the front side.
(Don't start placing them from the front side)
- * Make sure that 6 of the package trays are placed in a sleeve even if there are some fraction trays.

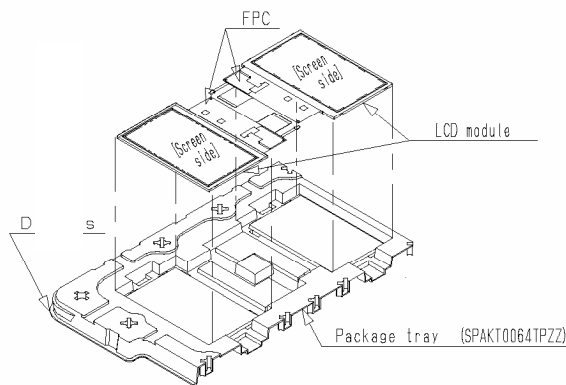

【How to store the set of the 6 package trays in the protection bag】

1. Place the package tray (6 package trays piled) into the protection bag.
2. Fold down the ends of corner of the protection bag and stick them on the top of the package tray with the crepe tape which is folded down the end.

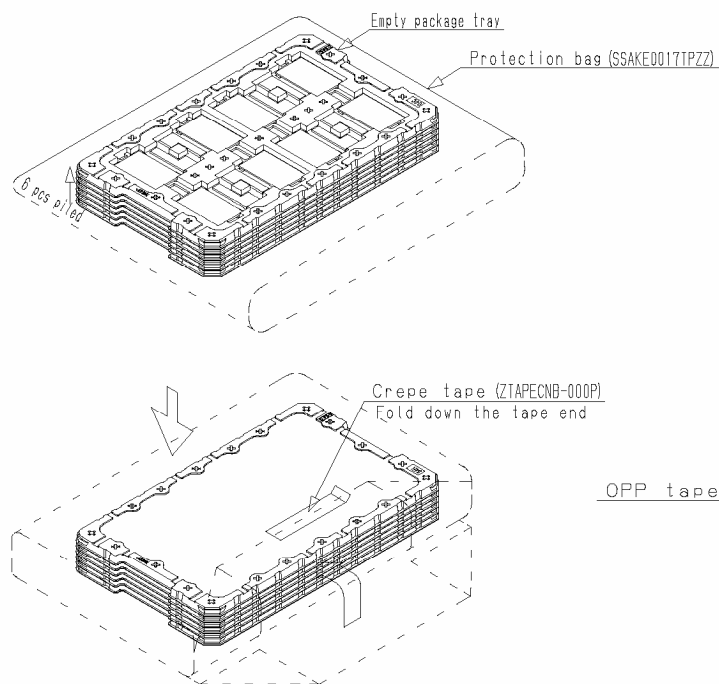

【How to store the set of package in the carton】

1. The set of the 6 package trays in a protection bag is placed in an inner sleeve and inserted in an outer sleeve.
(Make sure that the whole protection bag is encased in the outer sleeve without any parts of the bag being out of the sleeve.)
2. Seal the center and both sides of the bottom of the master carton with OPP tape forming an "H" pattern and pile up 2 of the outer sleeves.
3. Seal the center and both sides of the top of the master carton with OPP tape forming an "H" pattern.
4. stick a barcode label on the detail frame of the master carton.

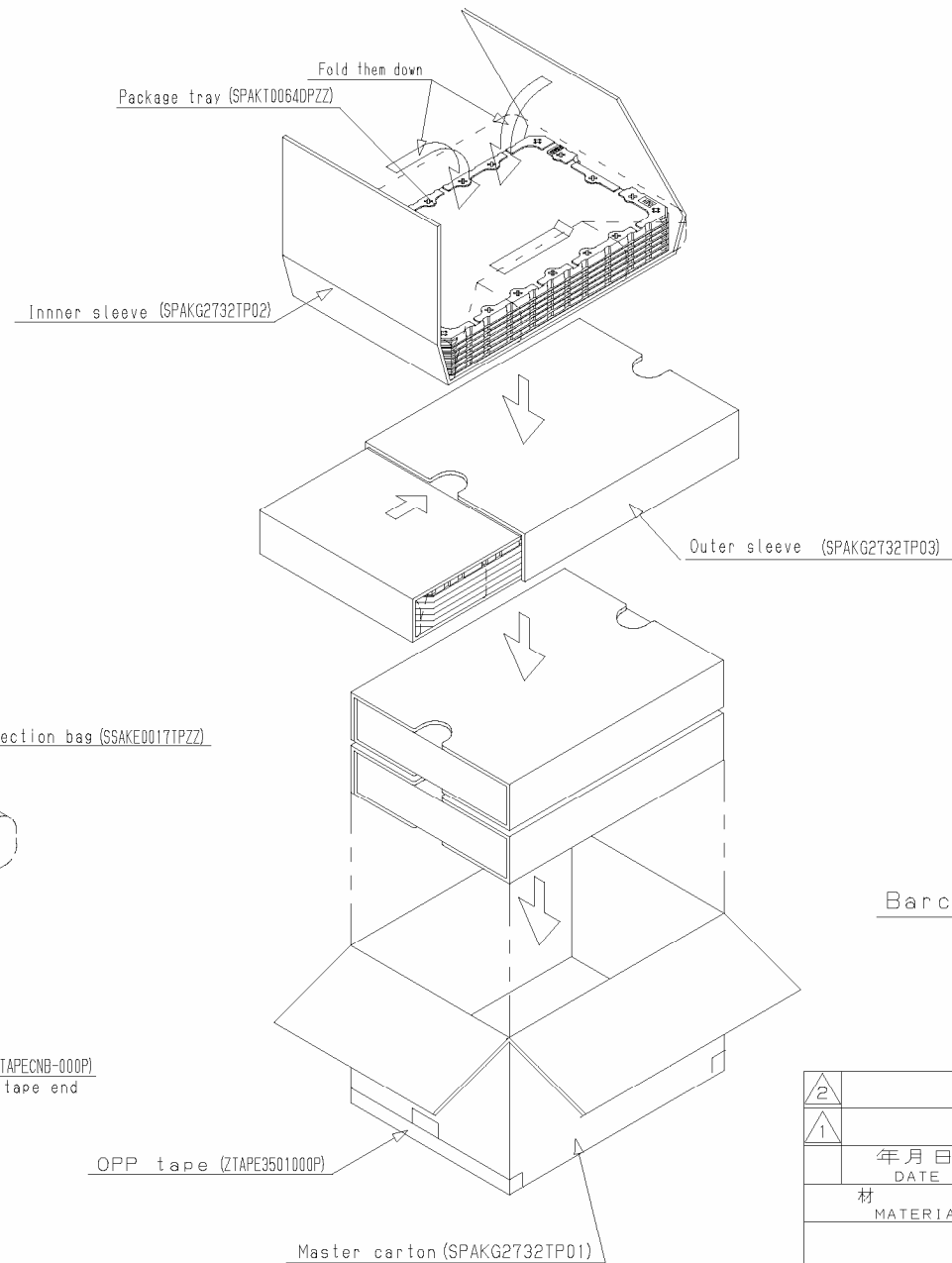

【Contents of the barcode label and the instruction of sticking】

Stick the barcode label on the detail frame of the master carton with the upper right joined with each other.



SHARP
Electronic Components

TYPE	社内品番: (4S) LQ043T3DX04K
QUANTITY	LotNO. : (1T) 2000. xx. xx
LOT (DATE)	Quantity: (0) 80 PCS
	ユーザー品番: _____
	シャープ物販用ラベルです。() ()

Barcode label (TLABK2001TPZZ)

【Packing specification】

Quantity	2 hor. x 4 vert. = 8 / tray, 8 x 5 trays = 40 / sleeve, 40 x 2 sleeves = 80 LCD modules / ctn		
The dim. of ctn	575x360x225 (H) The lim. of piling up : 8 ctn		
Part list	Description	Part code	Qty
	Set of package (Master carton)	SPAKG2732TPZZ (SPAKG2732TP01)	1 / 80 (1 / 80)
	(Inner sleeve)	(SPAKG2732TP02)	(2 / 80)
	(Outer sleeve)	(SPAKG2732TP03)	(2 / 80)
	Package tray	SPAKT0064TPZZ	12 / 80
	Protection bag	SSAKE0017TPZZ	2 / 80
	Crepe tape	ZTAPECNB-000P	40cm/80
	OPP tape	ZTAPE3501000P	329cm/80
	Barcode label	TLABK2001TPZZ	1 / 80

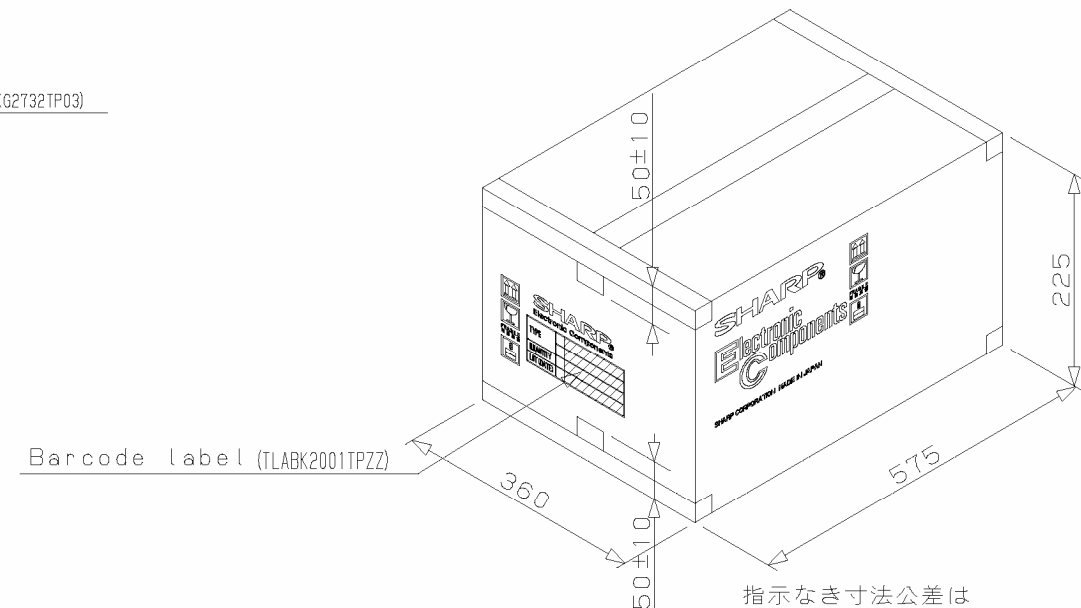

					LQ043T3DX04K		名称	Procedure of Packing
					LQ043T3DX04		NAME	
年月日	改定記事	設通 No	担当	適用機種				
DATE	REVISE		PREPA	MODEL				
材	質	板厚	仕	上	尺度			
MATERIAL		THICKNESS		FINISH	SCALE			
					1/10			
設計	写図	検図	検図	承認	ENGINEERING DEPARTMENT II MOBILE LCD DIVISION II		作成日付	
DESIGN	TRACE	CHECK	CHECK	APPROVE	MOBILE LCD GROUP		DATE	
平山					SHARP CORPORATION		図番	
							DRAWING. No	

Figure 4 Packing style

DelInt1/cad_data/pack_tel/LQ043T3DX01 (S)