

PREPARED BY: _____ DATE _____	SHARP	SPEC No. LCY-00123A
APPROVED BY: _____ DATE _____		FILE No. _____
		ISSUE: Nov. 28. 2000
		PAGE : 24 pages
	LIQUID CRYSTAL DISPLAY GROUP SHARP CORPORATION SPECIFICATION	APPLICABLE GROUP LIQUID CRYSTAL DISPLAY GROUP

DEVICE SPECIFICATION FOR

TFT - LCD module

MODEL No. LQ070T5CRQ1

CUSTOMER'S APPROVA

DATE _____

BY _____

PRESENTED

BY S. Yasuda
S. YASUDA
Department General manager
Development Engineering Dept. 2
TFT Division. 1
TFT LIQUID CRYSTAL DISPLAY GROUP
SHARP CORPORATION

NOTICE

This publication is the proprietary of SHARP and is copyrighted, with all rights reserved. Under the copyright laws, no part of this publication may be reproduced or transmitted in any form or by any means, electronic or mechanical for any purpose, in whole or in part, without the express written permission of SHARP. Express written permission is also required before any use of this publication may be made by a third party.

The application circuit examples in this publication are provided to explain the representative applications of SHARP's devices and are not intended to guarantee any circuit design or permit any industrial property right or other rights to be executed. SHARP takes no responsibility for any problems related to any industrial property right or a third party resulting from the use of SHARP's devices, except for those resulting directly from device manufacturing processes.

In the absence of confirmation by device specification sheets, SHARP takes no responsibility for any defects that occur in equipment using any of SHARP's devices, shown in catalogs, data books, etc. Contact SHARP in order to obtain the latest device specification sheets before using any SHARP's device.

SHARP reserves the right to make changes in the specifications, characteristics, data, materials, structures and other contents described herein at any time without notice in order to improve design or reliability. Contact SHARP in order to obtain the latest specification sheets before using any SHARP's device. Manufacturing locations are also subject to change without notice.

Observe the following points when using any device in this publication. SHARP takes no responsibility for damage caused by improper use of the devices.

The devices in this publication are designed for use in general electronic equipment designs, such as:

- Car Navigation system
- Automotive auxiliary information display
- Automotive audio visual equipment

The appropriate design measures should be taken to ensure reliability and safety when SHARP's devices are used for equipment such as:

- Transportation control and safety equipment (i.e., aircraft, trains, automobiles, etc.)
- Traffic signals
- Gas leakage sensor breakers
- Alarm equipment
- Various safety devices etc.

SHARP's devices shall not be used for equipment that requires extremely high level of reliability, such as:

- Military and space applications
- Nuclear power control equipment
- Medical equipment for life support

Contact a SHARP representative, in advance, when intending to use SHARP's devices for any "specific" applications other than those recommended by SHARP.

Contact and consult with a SHARP representative if there are any questions about the contents of this publication.

C O N T E N T S

	Page
(1) Introduction	2
(2) Features	2
(3) Construction and Outline	2
(4) Module geometry	2
(5) Input/Output terminal	3
(6) Absolute maximum ratings	7
(7) Electrical characteristics	8
(8) Optical characteristics	10
(9) Mechanical characteristics	12
(10) Display quality	12
(11) Handling instructions	12
(12) Shipping requirements	14
(13) Reliability test conditions	14
(14) Others	16
 Attached Figures	
Fig.1 Outline dimensions of TFT-LCD module	17
Fig.2 Construction of TFT-LCD module	18
Fig.3 Display mode	6
Fig.4 Input signal waveforms	19
Fig.5 PWM dimming timing	20
Fig.6 Recommended circuit of TFT-LCD module.....	21
Fig.7 Recommended circuit of PWM dimming	22
Fig.8 Packing form	23
 Attached sheets	
(Appendix-1) Adjusting method of optical common electrode DC bias voltage	24

(1) Introduction

The SHARP Color TFT-LCD module is an active matrix LCD (Liquid Crystal Display) produced by making the most of Sharp's expertise in liquid-crystal and semiconductor technologies.

The active device is amorphous silicon TFT (Thin Film Transistor). The module accepts full color video signal conforming to the NTSC(M) and PAL(B·G) system standards.

Module geometry(Mechanical specification): Table 1

(2) Features

- Utilizes a panel with a 16:9 aspect ratio, which makes the module suitable for use in wide screen systems.
- By adopting an active matrix drive, a picture with high contrast is realized.
- Through the use of TN-normally white mode, an image with highly natural color reproduction is realized.
- The 7.0" screen produces a high resolution image that is composed of 112,320 pixel elements in a stripe arrangement.
- Built-in video interface circuit (including chroma demodulator, picture tone) and control circuit responsive to NTSC composite video signal and NTSC/PAL analog RGB signal.
- The inverter circuit having-within for the backlight lighting-up(dimming is available)
- An anti-glare and low-reflection (AGLR with wide viewing angle) surface polarization plate is used.
- Viewing angle: 6 o'clock
- An inverted video display in the vertical as well as horizontal directions is possible.

(3) Construction and Outline

- Outline dimensions of TFT-LCD module : See Fig. 1
- The construction form figure : See Fig. 2
- The module consists of a TFT-LCD panel, drivers, control PWB mounted with electronic circuits, backlight, frame, front and rear shielding cases.

(4) Module geometry(Mechanical specification)

Table 1

Parameter	Specification	Unit	Remarks
Display format	112.320	Pixels	
	1440(H) × 234(V)	dots	
Active area	154.1 (H) × 87.0 (V)	mm	
Screen-size (Diagonal)	17.7 [7.0"]	cm	
Dot pitch	0.107(H) × 0.372(V)	mm	
Dot configuration	R·G·B Stripe configuration		
Outline dimension	170.0(W) × 103.5(H) × 17.5(D)	mm	【Note 4-1】
Mass	320(Max)	g	

【Note 4-1】 This measurement is typical, and see Fig.1 for the details .

(5)Input / Output terminal
5-1)TFT-LCD panel driving section

Table 2

Pin No.	Symbol	i/o	Description	Remarks
1	HSY	i/o	Input/output horizontal sync. signal(low active)	【Note5-1】
2	VSY	i/o	Input/output vertical sync. signal(low active)	【Note5-2】
3	PWMS	o	The voltage output for the dimming light control	【Note5-3】
4	NTP	i	Selection for NTSC or PAL	【Note5-4】
5	HRV	i	Turning the direction of horizontal scanning	【Note5-5】
6	VRV	i	Turning the direction of vertical scanning	【Note5-6】
7	MODS	i	Selection for display mode	【Note5-7】
8	MODW	i	Selection for display mode	【Note5-7】
9	MODN	i	Selection for display mode	【Note5-7】
10	VCC	i	power supply voltage (7 ~ 9 V)	
11	VBS	i	Composite video signal	
12	BRT	i	Brightness adjusting terminal	【Note5-8】
13	VR	i	video signal(Red)	
14	VG	i	video signal(Green)	
15	VB	i	video signal(Blue)	
16	GND1	i	signal GND	
17	CONT	i	Contrast adjusting terminal	【Note5-8】
18	COLOR	i	Color adjusting terminal	【Note5-8】
19	TINT	i	Tint adjusting terminal	【Note5-8】
20	GND1	i	signal GND	
21	CLKC	i	Change the input/output direction of CLK,HSY,VSY	【Note5-9】
22	CLK	i/o	Input/output clock signal	【Note5-10】
23	VSW	i	Selection video signal of Composite or RGB	【Note5-11】
24	PWMI	i	Input signal for backlight dimming	
25	VBL	i	power supply voltage for Back light	
26	VBL	i	power supply voltage for Back light	
27	GND2	i	Back light GND	
28	GND2	i	Back light GND	

'High' and 'Low' refer to table 5 [digital input voltage].

【Note5-1】 When CLKC="Hi", the output is a horizontal synchronizing signal synchronized by the SYN signal. When CLKC="Lo", the module is synchronized via the horizontal synchronizing signal input at this terminal.

【Note5-2】 When CLKC="Hi", the output is a vertical synchronizing signal synchronized by the SYN signal. When CLKC="Lo", the module is synchronized via the vertical synchronizing signal input at this terminal.

【Note5-3】 The PWM signal is a dedicated signal used to adjust the frequency for backlight adjustment. PWM backlight adjustment is easily accomplished by combining the HSY and PWM signals. Please note that the PWM signal should only be used when a standard NTSC or PAL is input. See Fig.5 for details.

【Note5-4】 NTP="Hi" : NTSC system
NTP="Lo" : PAL system

【Note5-5】 HRV="Hi" : Regular video
HRV="Lo" : Horizontally inverted video

【Note5-6】 VRV="Hi" : Regular video
VRV="Lo" : Vertically inverted video

【Note5-7】 Display mode settings are given in Table 3.

【Note5-8】 Adjusted by the DC voltage supplied to this pin.

They are adjusted to the optimum value on shipping, but, they can be re-adjusted by external circuit.

【Note5-9】 CLKC="Hi" : CLK,HSY and VSYS terminals are in the output mode.
CLKC="Lo" : CLK,HSY and VSYS terminals are in the input mode.

(6) Absolute maximum ratings

Table 4

GND=0V, T_a=25°C

Parameter		Symbol	MIN	MAX	Unit	Remarks
Positive power supply voltage		V _{IN}	+7.0	+9.0	V	
Analog input signals		V _i	—	2.0	V _{p-p}	【Note 6-1】
Digital input signals		V _I	-0.3	+5.4	V	【Note 6-2】
Adjusting terminal voltage		V _{adj}	-0.3	+5.4	V	【Note 6-3】
Storage temperature		T _{stg}	-40	+95	°C	【Note 6-4】
Operating temperature	Surface of panel	T _{op1}	-30	+85	°C	【Note 6-4, 5, 6】
	Environment	T _{op2}	-30	+60	°C	【Note 6-6, 7】

【Note 6-1】 VBS, VR, VG, VB terminals (Video signal)

【Note 6-2】 NTP, HRV, VRV, MODS, MODW, MODN, CLKC, VSW terminals

【Note 6-3】 BRT, CONT, COLOR, TINT terminals

【Note 6-4】 The temperature of panel surface must not exceed this rating.

【Note 6-5】 Maximum wet-bulb temperature must be less than 58°C. No dew condensation.

【Note 6-6】 The operating temperature assure only driving. Contrast, response time, the other display quality is judgment at 25°C.

【Note 6-7】 The temperature around considering that the backlight lighting-up generates heat. (The reference value)

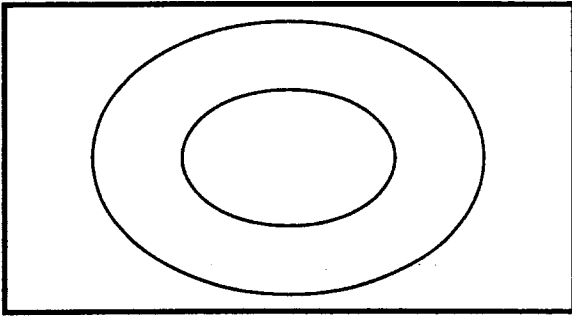

Fig.3-1 Full mode

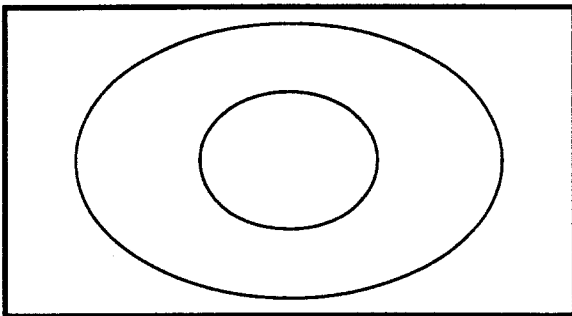

Fig.3-2 Wide 1 mode

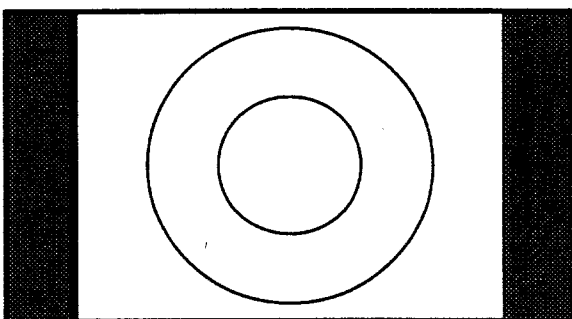

Fig.3-3 Normal mode

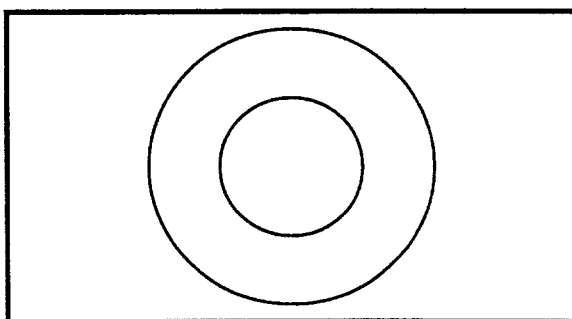

Fig.3-4 Cinema mode

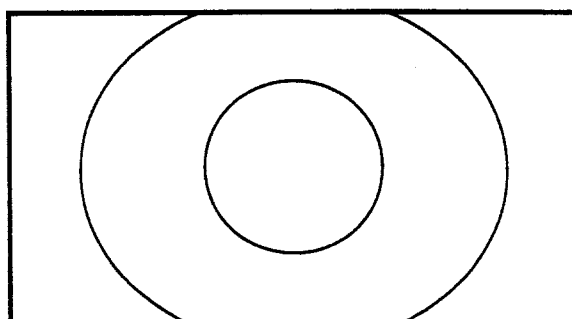

Fig.3-5 Wide 2 mode

Table 3 Display Method and Characteristics

MODS	MODW	MODN	Display mode	Characteristics	Source	example
H	H	H	Full mode	The picture is displayed with uniform enlargement in the horizontal direction, and the horizontal retrace line of the input signal cannot be seen. If the video sampling frequency of the image is fixed and a 4:3 video signal is displayed, the picture will be prominently oblong.	4:3 signal, Navigation signal	Fig.3-1
H	H	L	Wide mode 1	A 4:3 video signal is displayed with less feeling of incongruity than that in the full screen mode. Since the video horizontal sampling frequency is modulated in the horizontal direction, the degree of perfect roundness in the center of the screen is improved over that of the full screen mode.	4:3 signal	Fig.3-2
H	L	H	Normal mode	When displaying a 4:3 video signal, the displayed image is slightly less than perfectly round and the horizontal retrace line period is displayed at the two edges of the screen. With respect to the video horizontal sampling frequency, the center portion of the screen is slightly lower and the two edges become slightly higher. With respect to the horizontal retrace line period, a far better display is achieved than that of masking of the video signal by the VCS signal timing.	4:3 signal	Fig.3-3
H	L	L	Cinema mode	A letter-box type image (16:9 signal) is displayed over the central width of the screen. In the horizontal direction, full screen display is utilized. Due to the display being extended in the vertical direction, a slightly less than perfectly round image is displayed.	letter box type wide signal(16:9signal)	Fig.3-4
L	H	H	Wide mode 2	In the horizontal direction, the Wide 1 display mode is employed. Due to the display being extended in the vertical direction, the portion of the picture in the center of the screen is slightly less than perfectly round. Also due to extending in the vertical direction, the upper and lower portions of the image are not displayed.	4:3 signal	Fig.3-5
L	H	L	test	This mode is unusable as it is the test mode.	—	—
L	L	H	test	This mode is unusable as it is the test mode.	—	—
L	L	L	test	This mode is unusable as it is the test mode.	—	—

【Note5-10】 When CLKC="Hi", the output level is low.

When CLKC="Lo", module operation is based on the input clock signal. This signal should correspond to sampling timing of the horizontal direction image. NTP,MODS,MODW and MODN should be "Hi" then CLKC="Lo".

【Note5-11】 Selects input signals, composite or analog RGB.

When VSW is "Lo", composite video signal is selected.(input terminal is No.11:VBS)

When VSW is "Hi", analog RGB signal is selected.(input terminal is No.11:VBS and No.13 to No.15:VR,VG,VB)

(7)Electrical characteristics

7-1)Recommended operating conditions

Table 5

GND=0V, Ta=25°C

Parameter	Symbol	MIN.	TYP.	MAX.	Unit	Remarks		
Power supply voltage	VIN	+7.0	+8.0	+9.0	V			
Analog input voltage	Amplitude	V1	0.7	1.0	2.0	Vp-p	【Note7-1】	
	Amplitude	V2	0	0.7	2.0	Vp-p	【Note7-2】	
	DC component	Vide	-0.1	0	+1.0	V	【Note7-3】	
Digital input voltage	Hi	Vih	+3.5	-	+5.0	V	【Note7-4】	
	Lo	Vil	0	-	+1.5	V		
Input horizontal sync. component	frequency	NTSC	fH(N)	15.13	15.73	16.33	kHz	CLKC="Hi" 【Note7-5】
		PAL	fH(P)	15.03	15.63	16.23		
	pulse width	NTSC	τ HI(N)	4.2	4.7	5.2	μ s	
		PAL	τ HI(P)	4.2	4.7	5.2		
	rising time	τ rHI1	-	-	0.5	μ s		
falling time	τ fHI1	-	-	0.5	μ s			
Input vertical sync. component	frequency	NTSC	fV(N)	fH/284	fH/262	fH/258	Hz	CLKC="Hi" 【Note7-6】
		PAL	fV(P)	fH/344	fH/312	fH/304		
	pulse width	NTSC	τ VI(N)	-	3H	-	μ s	
		PAL	τ VI(P)	-	2.5H	-		
	rising time	τ rVI	-	-	0.5	μ s		
falling time	τ fVI	-	-	0.5	μ s			
Input clock	frequency	fCLI	9.3	9.5	9.7	MHz	CLKC="Lo"	
	Hi pulse width	τ WH	20.0	-	-			ns
	Lo pulse width	τ WL	20.0	-	-			
	rising time	τ rCLI	-	-	10.0			
	falling time	τ fCLI	-	-	10.0			
Input horizontal sync. signal	frequency	fHI	fCLI/650	fCLI/608	fCLI/590	kHz	CLKC="Lo"	
	pulse width	τ HI	1	5	9			μ s
	rising time	τ rHI2	-	-	0.05			
	falling time	τ fHI2	-	-	0.05			
Input vertical sync. signal	frequency	fVI	50	fHI/262	fHI/258	Hz	CLKC="Lo"	
	pulse width	τ VI	1H	3H	5H			μ s
Data setup time	tSU1	25	-	-	ns			
Data hold time	tHO1	25	-	-	ns			
Data setup time	tSU2	1.0	-	-	μ s			
Data hold time	tHO2	1.0	-	-	μ s			
Terminal voltage applicable to brightness	Vbrt	+2.0	+2.1	+2.3	V			

【Note7-1】 VBS terminal (composite video signal)

Input impedance : 75 Ω

【Note7-2】 VR.VG.VB terminals (Analog RGB)

【Note7-3】 VBS.VR.VG.VB terminals

【Note7-4】 HSY.VSY.NTP.HRV.VRV.MODS.MODW.MODN.CLKC.CLK.VSW terminals

Input impedance : >10k Ω

【Note7-5】 VBS (horizontal sync. component)

【Note7-6】 VBS (vertical sync. component)

7-2) Power consumption

Table 6

Ta=25°C

Parameter	Symbol	Voltage	MIN.	TYP.	MAX.	Unit	Remarks
Supply current	Icc	VIN=+8.0V	--	220	300	mA	
Lamp power consumption	IL	VIN=+8.0V	--	750	850	mA	Dimmer=100%

7-3) Display time range

Displaying the following range within video signals.

(1) NTSC(M) mode (NTP='Hi', CLKC='Hi')

(a1) Horizontally : 13.0 ~ 63.3 μ s from the falling edge of HSY. (full, wide1, 2, cinema)

(a2) Horizontally : 7.6 ~ 68.8 μ s from the falling edge of HSY. (normal)

(b1) Vertically : 20 ~ 253 H from the falling edge of VSY. (full, wide1, normal)

(b2) Vertically : 49 ~ 224 H from the falling edge of VSY. (cinema)

(b3) Vertically : 42 ~ 228 H from the falling edge of VSY. (wide2)

(2) PAL(B·G) mode (NTP='Lo', CLKC='Hi')

Displaying the following range within video signals.

(a1) Horizontally : 13.0 ~ 63.3 μ s from the falling edge of HSY. (full, wide1, 2, cinema)

(a2) Horizontally : 7.6 ~ 68.8 μ s from the falling edge of HSY. (normal)

(b1) Vertically : 26~298 H from the falling edge of VSY. (full, wide1, normal)

However, the video signals of (14n+12)H, (14n+20)H/Even field.

(14n+17)H, (14n+23)H/Odd field (n=1, 2, ..., 20)

are not displayed on the module.

(b2) Vertically : 40~284 H from the falling edge of VSY. (cinema)

However, the video signals of (42n)H, (42n+22)H/Even field.

(42n+13)H, (42n+35)H/Odd field (n=1, 2, ..., 20)

are not displayed on the module.

(b3) Vertically : 35~289 H from the falling edge of VSY. (wide2)

However, the video signals of (22n+14)H, (22n+24)H/Even field.

(22n+21)H, (22n+31)H/Odd field (n=1, 2, ..., 20)

are not displayed on the module.

(3) External clock mode (NTP='Hi', CLKC='Lo')

Displaying the following range within video signals.

(a) Horizontally : 103 ~ 582 clk from the falling edge of HSY.

(clk means input external clock.)

(b) Vertically : 20 ~ 253 H from the falling edge of VSY.

(8)Optical characteristics

Table 7 $T_a=25^{\circ}\text{C}$

Parameter	Symbol	Condition	Min	Typ	Max	Unit	Remarks	
Viewing angle range	$\Delta \theta 11$	$CR \geq 5$	60	65	-	$^{\circ}$ (degree)	【Note 8-1, 2, 3】	
	$\Delta \theta 12$		45	50	-	$^{\circ}$ (degree)		
	$\Delta \theta 2$		60	65	-	$^{\circ}$ (degree)		
Contrast ratio	CRmax	Optimal	60	-	-		【Note 8-2, 3】	
Response time	Rise	$\theta = 0^{\circ}$	-	30	60	ms	【Note 8-2, 4】	
	Fall		-	50	100	ms		
Luminance	Y		260	350	-	cd/m^2	【Note 8-5】	
White chromaticity	x	Dimmer=100%	0.263	0.313	0.363		【Note 8-5】	
	y		0.279	0.329	0.379			
Lamp life time	+25 $^{\circ}\text{C}$	-	continuation	10,000	-	-	hour	【Note 8-6】
	-30 $^{\circ}\text{C}$	-	intermission	2,000	-	-	time	【Note 8-7】

【Note 8-1】 Viewing angle range is defined as follows.

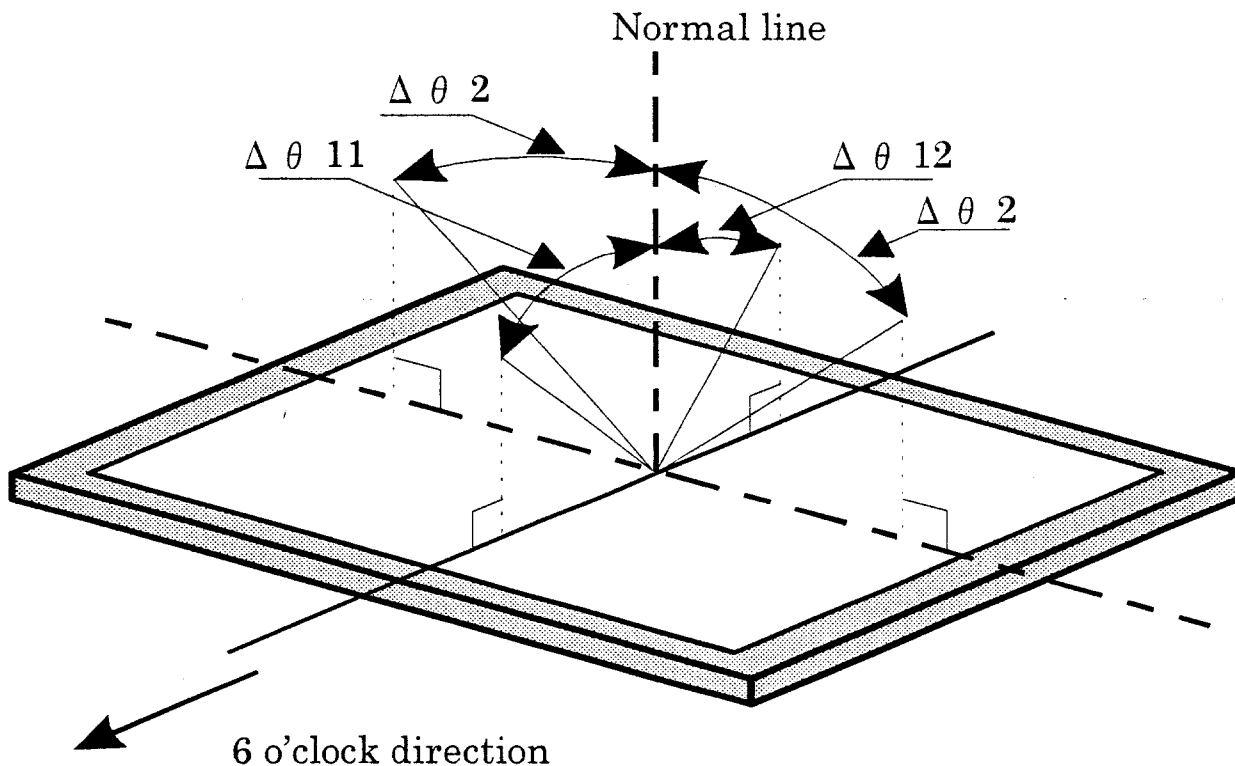

Fig. (i) definition for viewing angle

【Note 8-2】 Applied voltage condition:

- (1) VDC is adjusted so as to attain maximum contrast ratio.
- (2) Adjusting voltage (BRT, CONT, COLOR, TINT) is open.
- (3) Input video signal of standard black level and 100% white level.

【Note 8-3】 Contrast ratio is defined as follows:

$$\text{Contrast ratio (CR)} = \frac{\text{Photodetector output with LCD being "white"}}{\text{Photodetector output with LCD being "black"}}$$

【Note 8-4】 Response time is obtained by measuring the transition time of photodetector output, when input signals are applied so as to make the area "black" to and from "white".

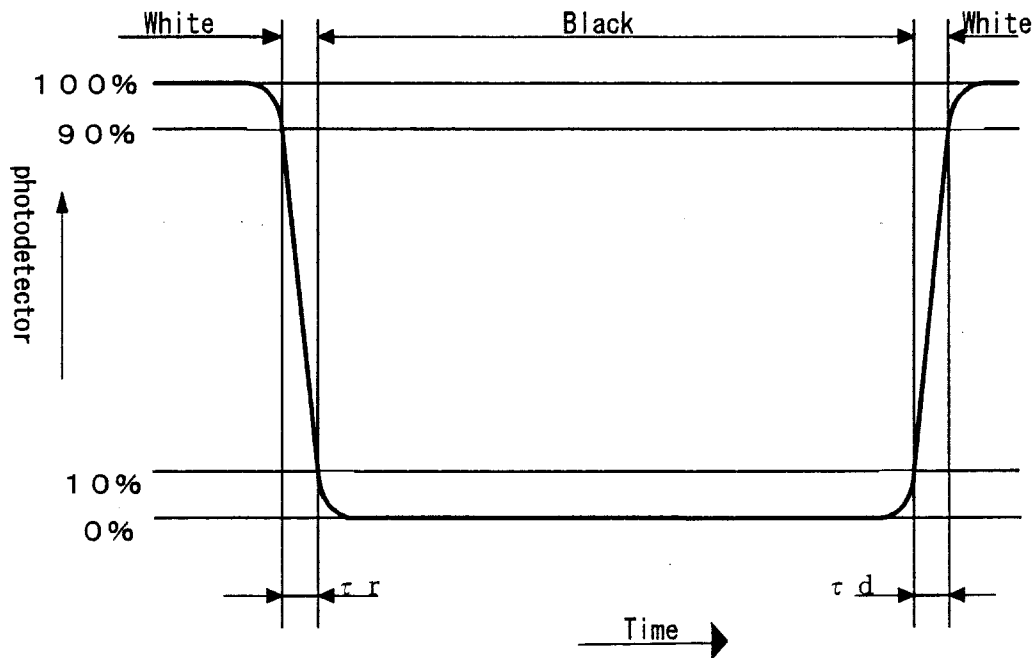

Fig. (ii)

【Note 8-5】 Measured on the center area of the panel at a viewing cone 1° by TOPCON luminance meter BM-7. (After 10 minutes operation)

【Note 8-6】 Lamp life time is defined as the time when the brightness of the panel not to become less than 50% of the original value.

(operation conditions)

Current dimming: PWM dimming 100%~5%

【Note 8-7】 The intermittent cycles is defined as a time when brightness not to become under 50% of the original value under the condition of following cycle. (See Fig. (iii).)

(condition)

Ambient temperature: -30°C

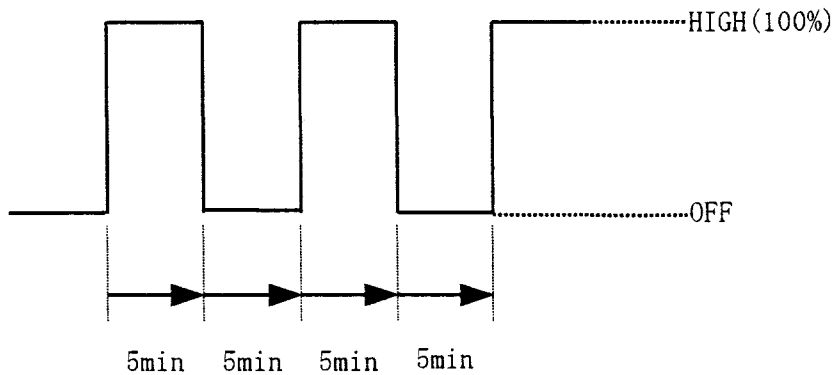

Fig. (iii)

(9) Mechanical characteristics

9-1) External appearance

Do not exist extreme defects. (See Fig. 1)

9-2) Panel toughness

The panel shall not be broken, when 19N is pressed on the center of the panel by a smooth sphere having 15 mm diameter.

Caution: In spite of very soft toughness, if, in the long-term, add pressure on the active area, it is possible to occur the functional damage.

9-3) Input/output connector performance

A) Input/output connectors for the operation of LCD module (28 pin)

Table 8. I/O connector of module driving

Symbol	Used Connector	Manufacture
CN1	006208500028710	Kyocera elco co.

(10) Display quality

The display quality of the color TFT-LCD module shall be in compliance with the incoming Inspection Standard.

(11) Handling instructions

11-1) Mounting of module

The TFT-LCD module is designed to be mounted on equipment using the mounting tabs in the four corners of the module at the rear side.

On mounting the module, as the M2.5 tapping screw (fastening torque is 0.35 through 0.45N·m) is recommended, be sure to fix the module on the same plane, taking care not to wrap or twist the module.

To pushing module, (ex. touching switch etc.) causes disordered image.

So taking care not to conduct directly for LCD module.

Please power off the module when you connect the input/output connector.

11-2) Precautions in mounting

- ① Polarizer which is made of soft material and susceptible to flaw must be handled carefully.

Protective film (Laminator) is applied on the surface to protect it against scratches and dirt.

It is recommended to peel off the laminator immediately before the use, taking care of static electricity.

- ② Precautions in peeling off the laminator

A) Working environment

When the laminator is peeled off, static electricity may cause dust to stick to the polarizer surface. To avoid this, the following working environment is desirable.

- a) Floor: Conductive treatment of $1M\Omega$ or more on the tile
(conductive mat or conductive paint on the tile)
- b) Clean room free from dust and with an adhesive mat on the doorway
- c) Advisable humidity: 50%~70% Advisable temperature: 15°C~27°C
- d) Workers shall wear conductive shoes, conductive work clothes, conductive gloves and an earth band.

B) Working procedures

- a) Direct the wind of discharging blower somewhat downward to ensure that module is blown sufficiently. Keep the distance between module and discharging blower within 20 cm. (See Fig. (iv).)
- b) Attach adhesive tape to the laminator part near discharging blower so as to protect polarizer against flaw. (See Fig. (iv).)
- c) Peel off laminator, pulling adhesive tape slowly to your side taking 5 or more second.
- d) On peeling off the laminator, pass the module to the next work process to prevent the module to get dust.
- e) Method of removing dust from polarizer
 - Blow off dust with N₂ blower for which static electricity preventive measure has been taken.
 - Since polarizer is vulnerable, wiping should be avoided.
 But when the panel has stain or grease, we recommend to use adhesive tape to softly remove them from the panel.

③When metal part of the TFT-LCD module (shielding lid and rear case) is soiled, wipe it with soft dry cloth. For stubborn dirties, wipe the part, breathing on it.

④Wipe off water drop or finger grease immediately. Long contact with water may cause discoloration or spots.

⑤TFT-LCD module uses glass which breaks or cracks easily if dropped or bumped on hard surface. Handle with care.

⑥Since CMOS LSI is used in this module, take care of static electricity and earth your body when handling.

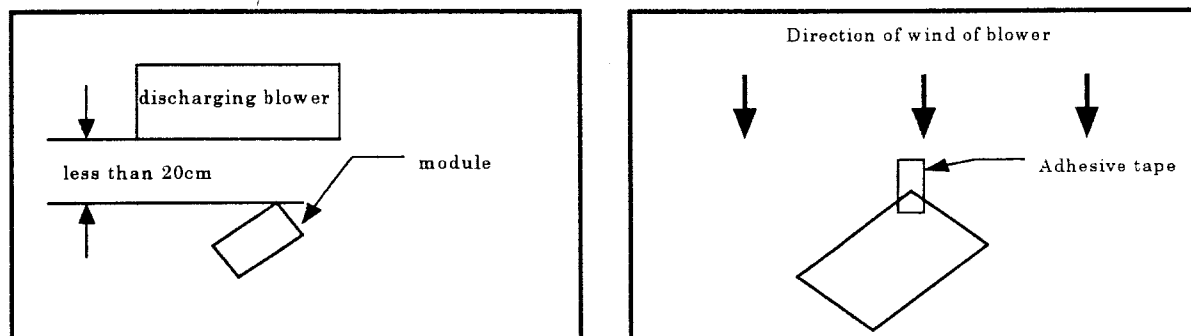

Fig . (iv)

11-3) Precautions in adjusting module

Adjusting volumes on the rear face of the module have been set optimally before shipment. Therefore, do not change any adjusted values.

If adjusted values are changed, the specifications described here may not be satisfied.

11-4) Caution of product design

The LCD module shall be protected against water salt-water by the waterproof cover.
Please take measures to interferential radiation from module,
not to interfere surrounding appliances.

11-5) Others

- ① Do not expose the module to direct sunlight or intensive ultraviolet rays for many hours; liquid crystal is deteriorated by ultraviolet rays.
- ② Store the module at a temperature near the room temperature. At lower than the rated storage temperature, liquid crystal solidifies, causing the panel to be damaged. At higher than the rated storage temperature, liquid crystal turns into isotropic liquid and may not recover.
- ③ The voltage of beginning electric discharge may over the normal voltage because of leakage current from approach conductor by to draw lump read lead line around. If LCD panel breaks, there may be a possibility that the liquid crystal escapes from the panel. Since the liquid crystal is injurious, do not put it into the eyes or mouth. When liquid crystal sticks to hands, feet or clothes, wash it out immediately with soap.
- ④ Observe all other precautionary requirements in handling general electronic components.

(12) Shipping requirements

12-1) Packing form is shown in Fig. 6.

12-2) Carton storage condition

- ① Number of layers of cartons in pile : 7 layers max.
- ② Environmental condition
 - Temperature 0°C to 40°C
 - Humidity 60 %PH or less (at 40°C)
No dew condition even at a low temperature and high humidity
 - Atmosphere Harmful gases such as acid and alkali which corrode electronic components and wires must not be detected.
 - Storage period About 3 months
 - Opening of package To prevent TFT-LCD module from being damaged by static electricity, adjust the room humidity to 50%PH or higher and provide an appropriate measure for electrostatic earthing before opening the package.

(13) Reliability test conditions

Reliability test conditions for the TFT-LCD module are shown in Table 9.

Reliability Test Conditions for TFT-LCD module

Table 9

No	Test items	Test condition
1	High temperature storage test	Ta=+95°C 240H
2	Low temperature storage test	Ta=-40°C 240H
3	High temperature and high humidity operating test	Tp=+60°C (95%RH) 240H
4	High temperature operating test	Ta=+85°C 240H
5	Low temperature operating test	Ta=-30°C 240H
6	Electrostatic discharge test	±200V·200pF(0Ω), Once for each terminal
7	Shock test	980m/s ² ·6ms, ±X, ±Y, ±Z 3 times for each direction (JIS C0041, A-7 Condition C)
8	Vibration test	Frequency range : 8~33.3Hz Stroke : 1.3mm Sweep : 33.3~400Hz Acceleration : 28.4m/s ² Cycle : 15 minutes X, Z 2 hours for each directions, 4 hours for Y direction (total 8 hours) 【caution】 (JIS D1601)
9	Heat shock test	-30°C~ +85°C, 200cycles (0.5H) (0.5H)

Ta = Ambient temperature

Tp = Panel temperature

【Evaluation result criteria】

Under a display quality test conditions with normal operation state, there shall be no change which may affect practical display function.

【Caution】 X, Y, Z directions are shown as follows:

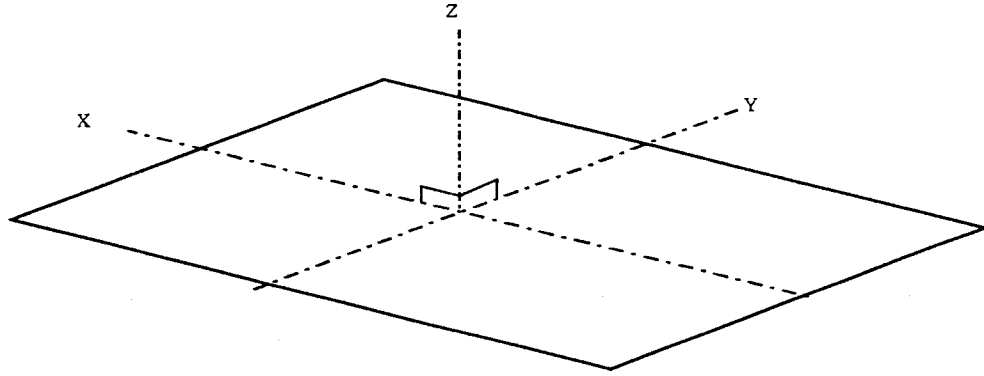

(14) Others

14-1) Indication of lot number

The lot number is shown on a label. Attached location is shown in Fig.3(Outline Dimensions).

Indicated contents of the label

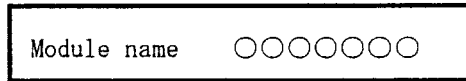

Model No.

lot No.

- Contents of lot No.
- the 1st figure .. production year (ex. 2000 : 0)
 - the 2nd figure .. production month 1, 2, 3,, 9, X, Y, Z
 - the 3rd~7th figure .. serial No. 00001~
 - the 8th figure .. revision marks A, B, C...

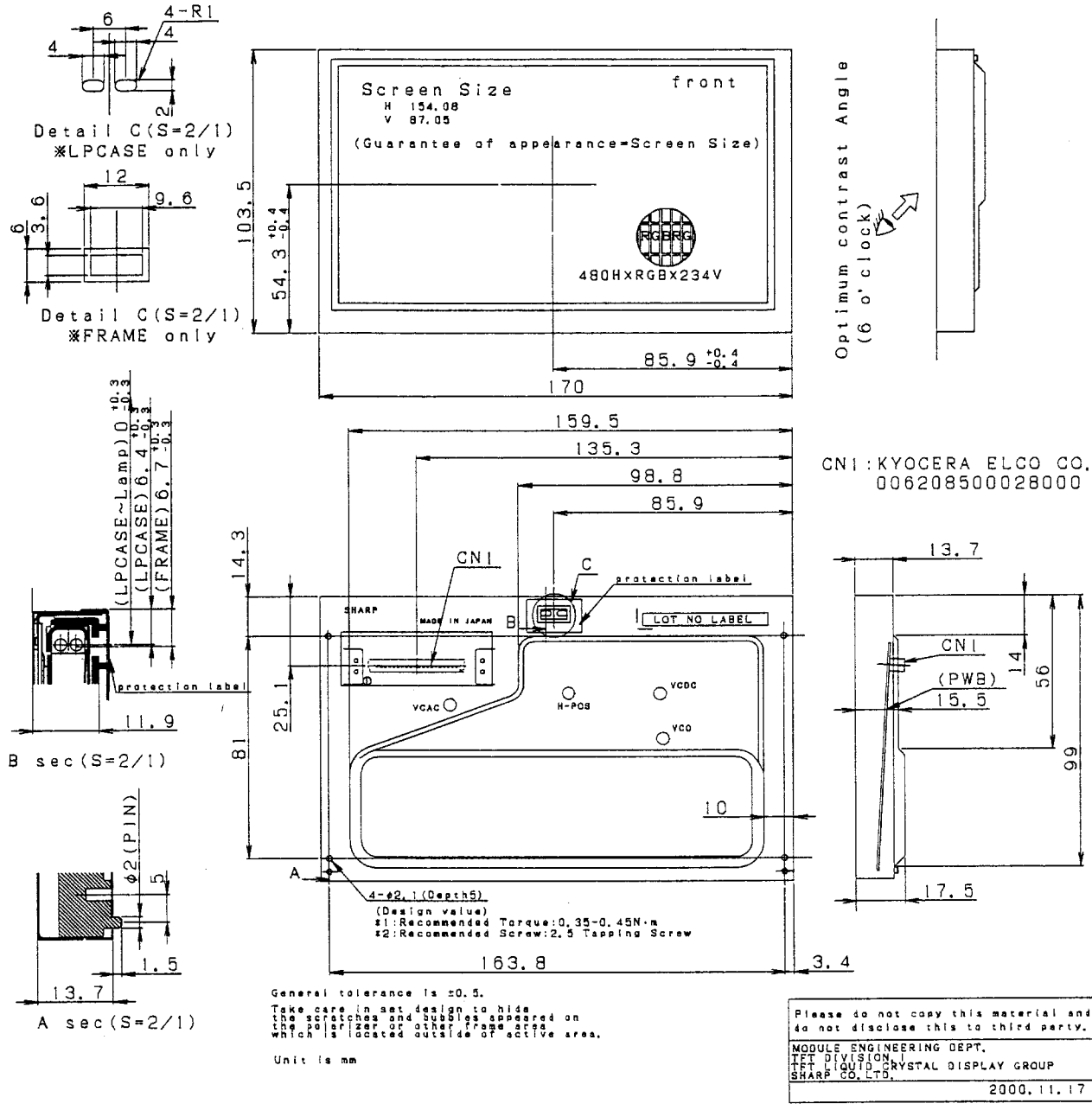

Fig.1 Outline dimension of TFT-LCD module

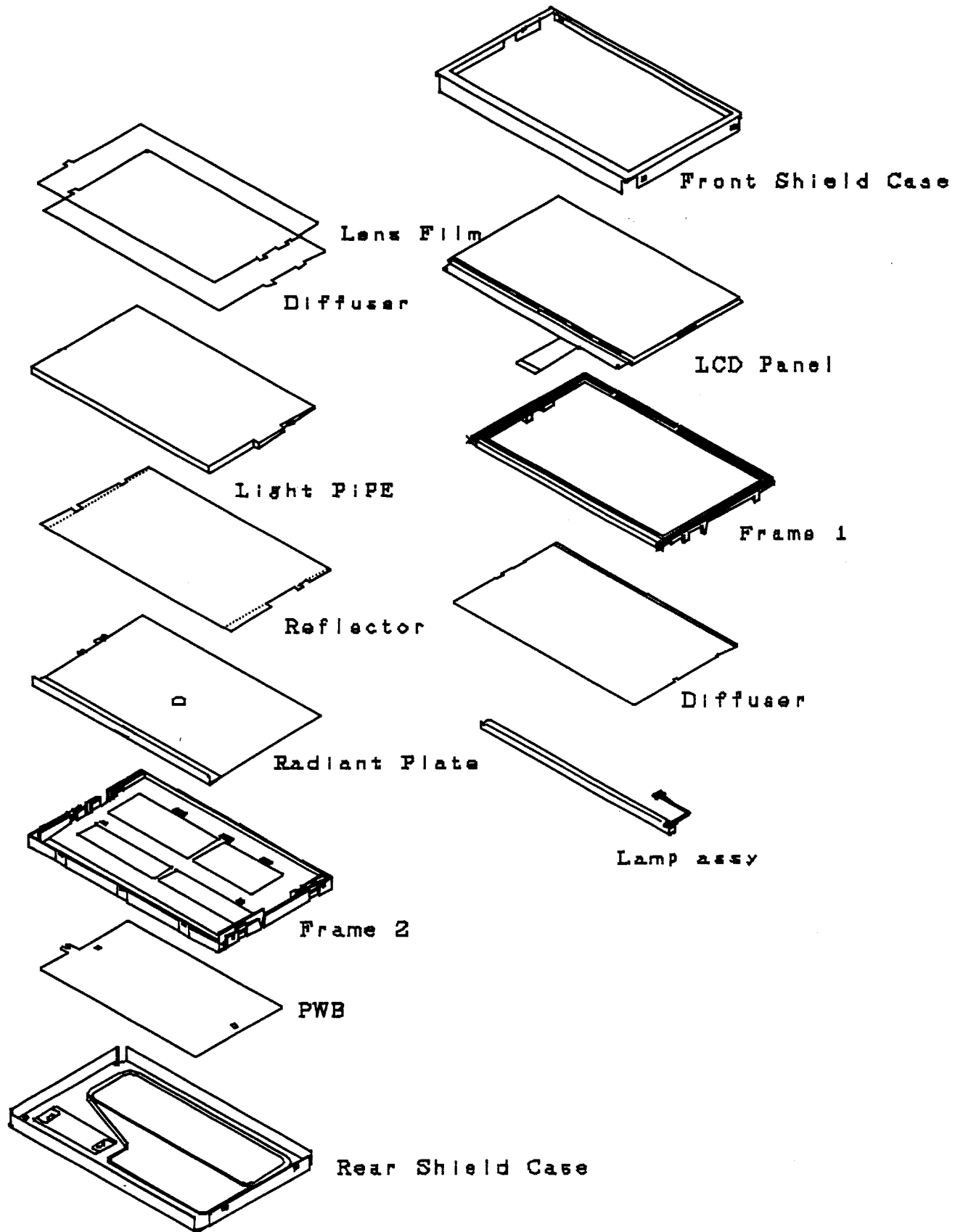

Fig.2 The construction of TFT-LCD module

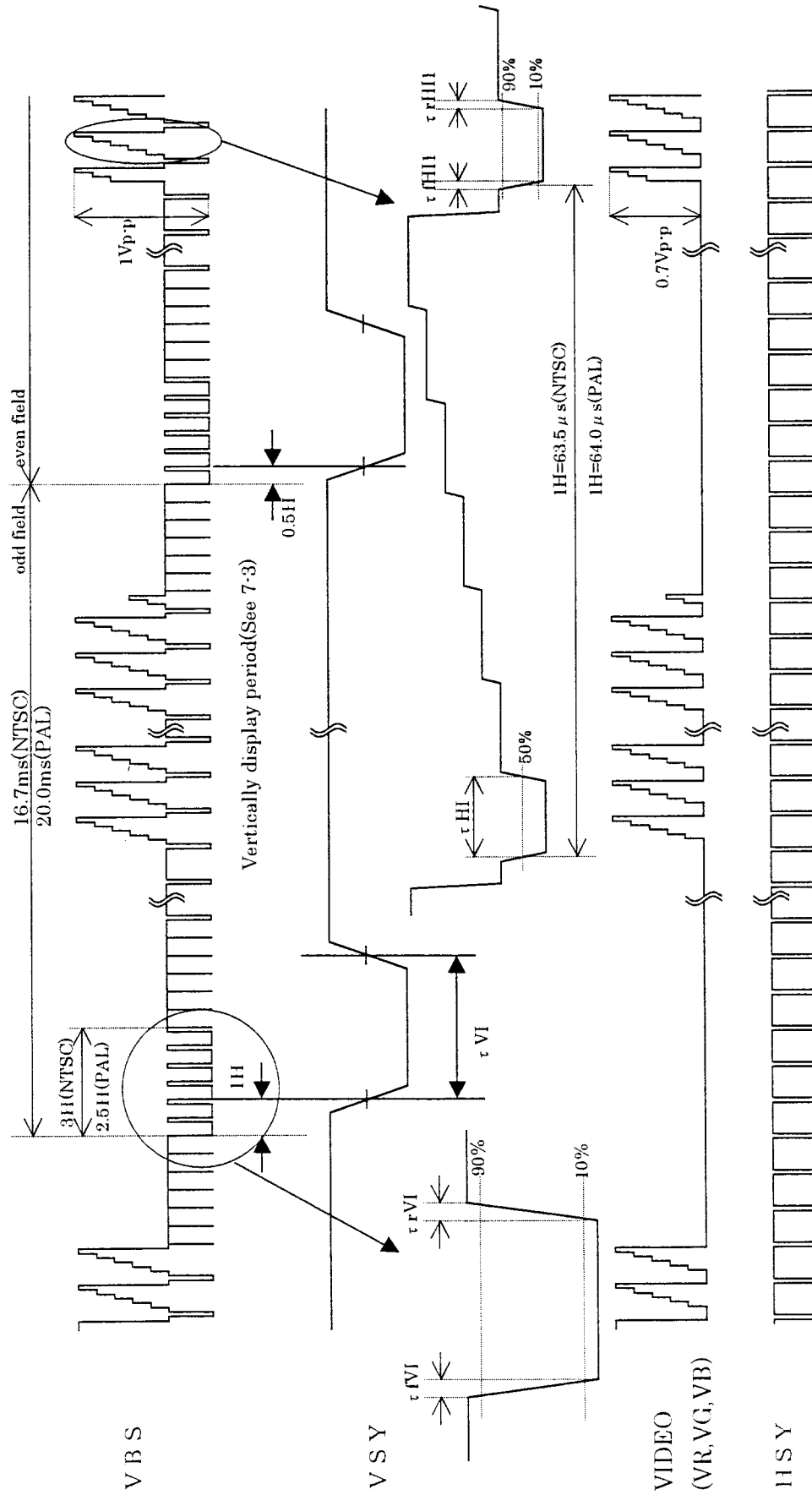

Fig.4 Input signal waveforms

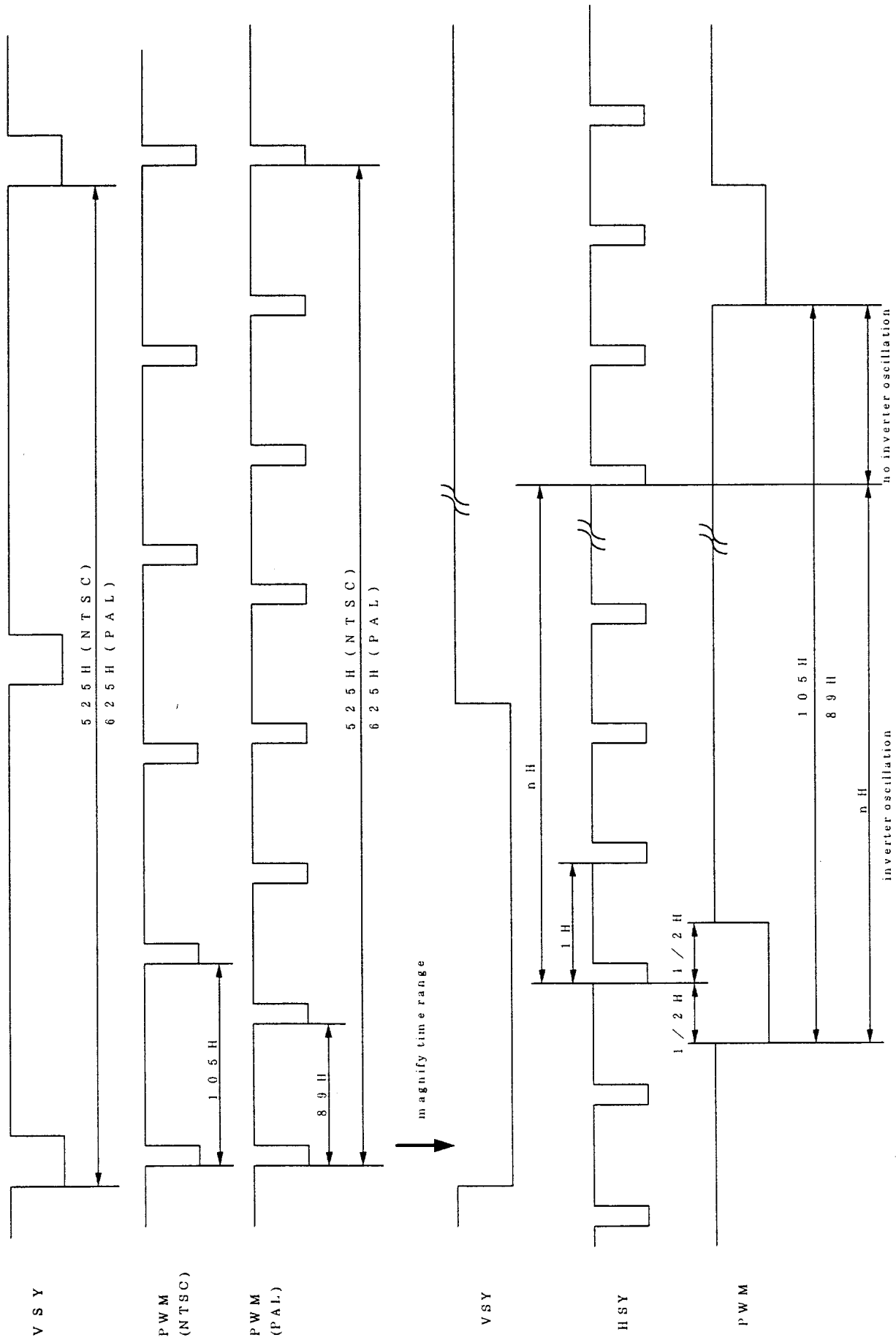

Fig. 5 PWM dimming timing

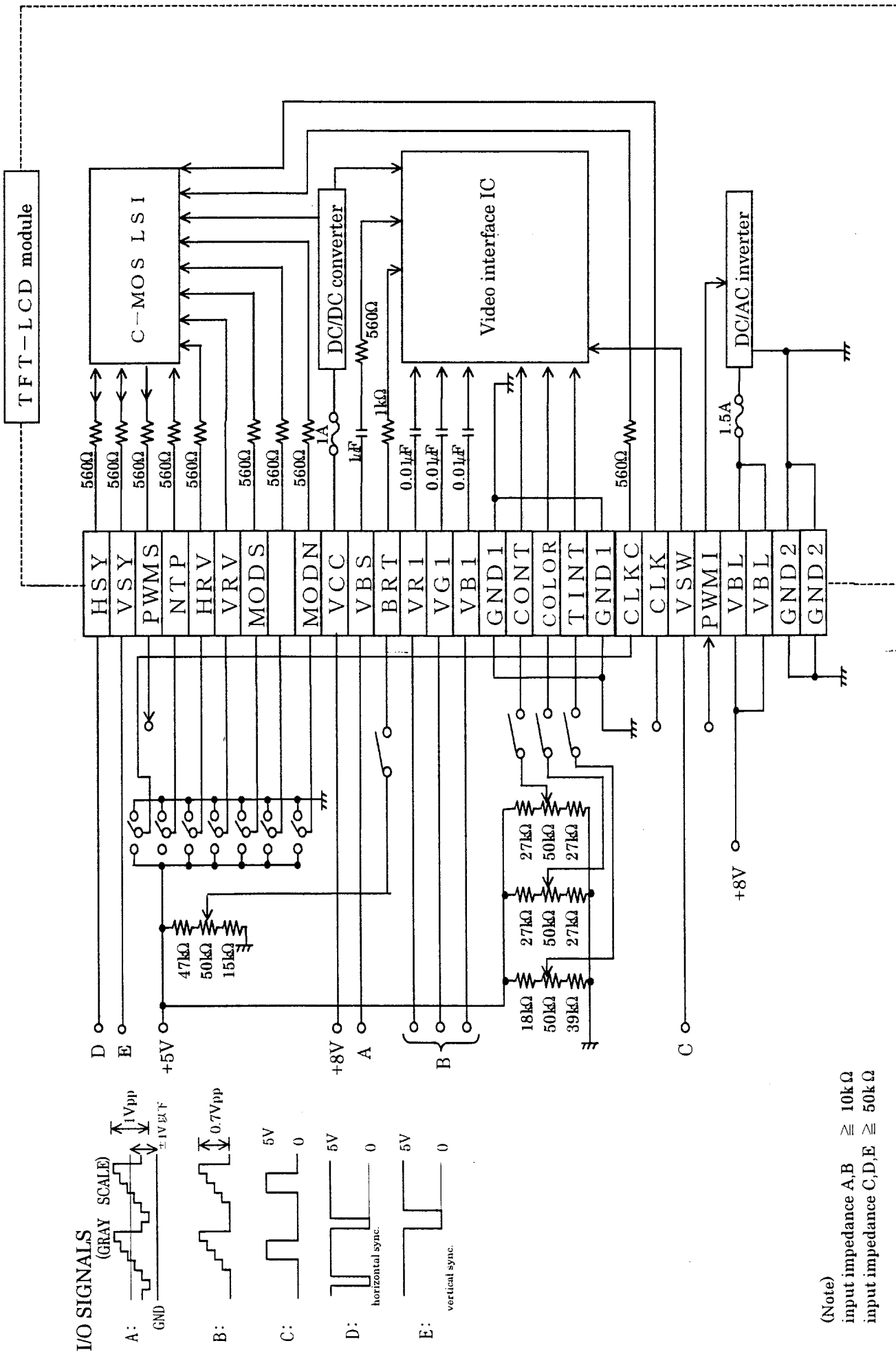

Fig.6 Recommended circuit of TFT-LCD module

(Note)
 input impedance A,B $\cong 10k\Omega$
 input impedance C,D,E $\cong 50k\Omega$

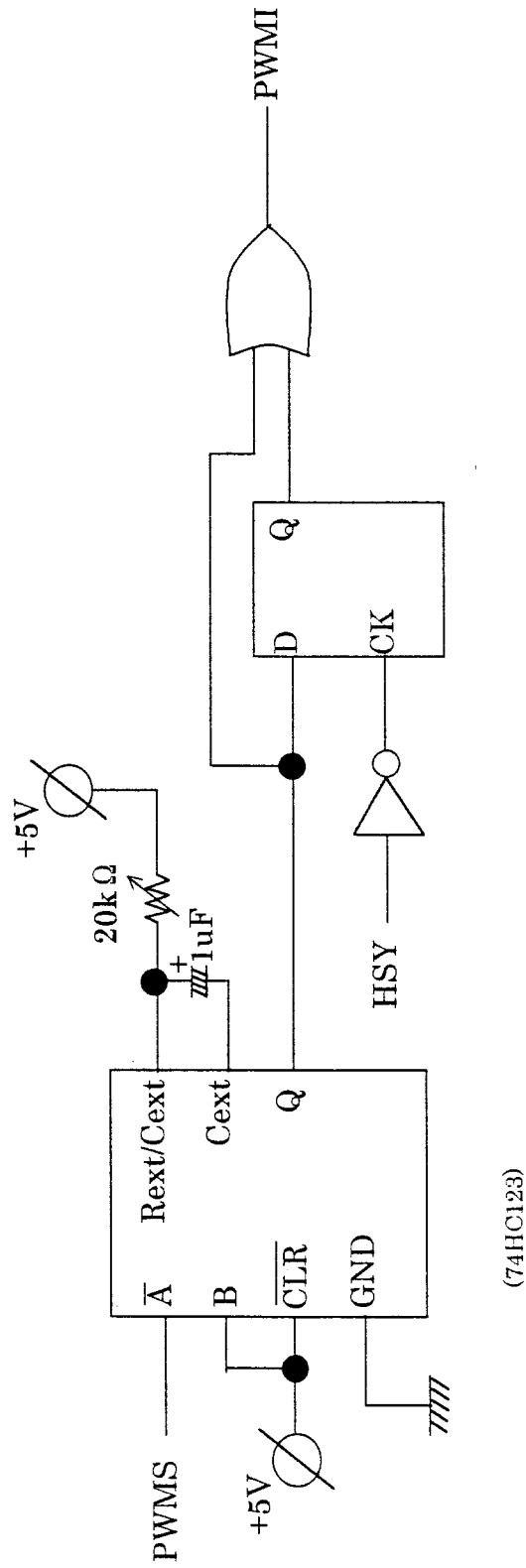

Fig7. recommended circuit of PWM dimming

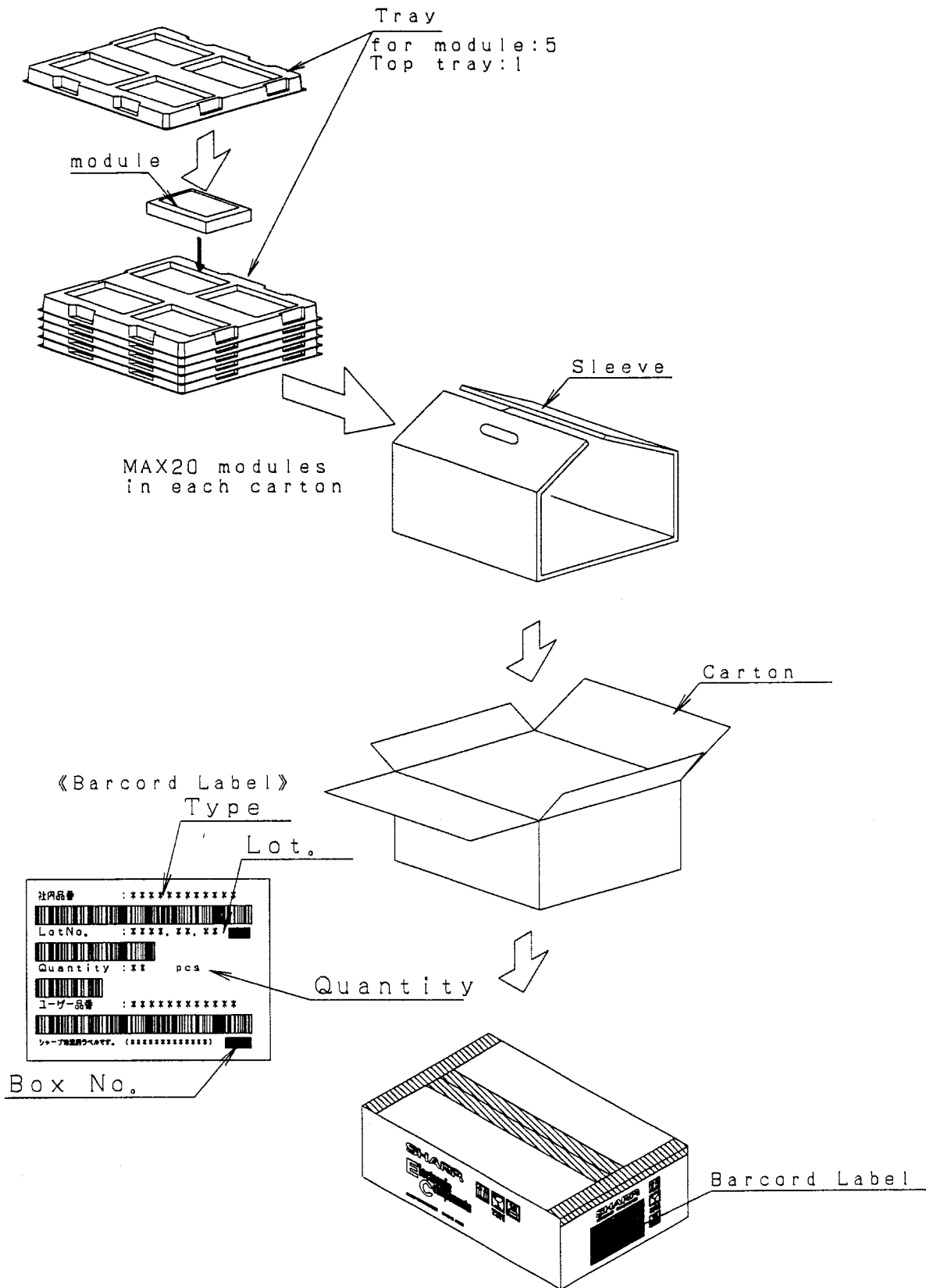

Fig.8 Packing form

(Appendix 1)

Adjusting Method of Optimum Common electrode DC Bias Voltage

To obtain optimum DC bias Voltage of common electrode driving signal, photo-electric devices are very effective, and the accuracy is within 0.1V.(in visual examination method, the accuracy is about 0.5V because of the difference among individuals.)

To obtain optimum common electrode DC bias voltage, there is a measurement method as follows:

Measurement of flicker method

DC bias voltage is adjusted so as to minimize NTSC:60Hz(30Hz)/PAL:50Hz(25Hz)flicker.

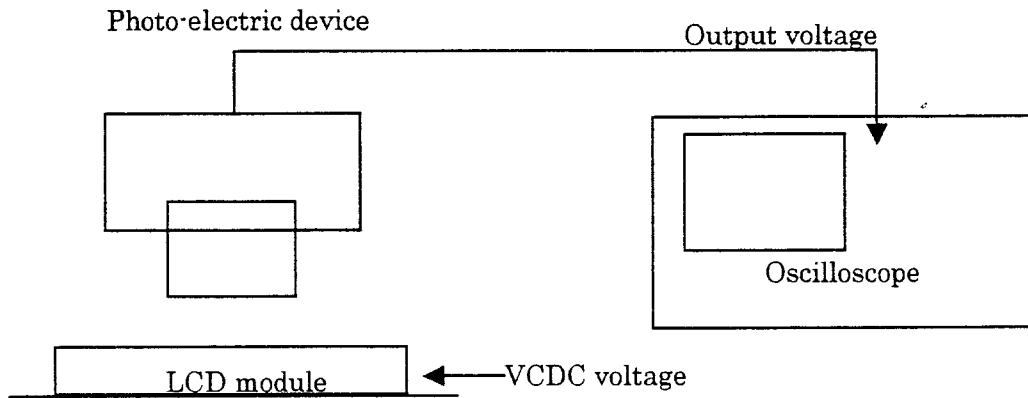

Fig.A Measurement system

《Measurement of flicker》

Photo-electric output voltage is measured by an oscilloscope at a system shown in Fig.A

DC bias voltage must be adjusted so as to minimize the 60Hz(30Hz)[NTSC]/50Hz(25Hz)[PAL] flicker with DC bias voltage changing slowly.(Fig.B)

