

PREPARED BY: Kondoh DATE 17. Jan. 2008

APPROVED BY: S. Sekido DATE 17. Jan. 2008

[Signature] DATE 17. Jan. 2008
Koiwa

SHARP

MOBILE LIQUID CRYSTAL
DISPLAY GROUP
SHARP CORPORATION
SPECIFICATION

SPEC No. LCY-07084A

FILE No.

ISSUE: Jan. 16. 2008

PAGE : 27 pages

DEVICE SPECIFICATION FOR
TFT - LCD module
MODEL No. LQ070Y5DG06

CUSTOMER'S APPROVAL

DATE _____

BY _____

PRESENTED

BY for M. Nakaya

H. Yamada
Department General manager
Engineering Department
Mobile LCD Division IV
MOBILE LIQUID CRYSTAL DISPLAY GROUP
SHARP CORPORATION

TFT - LCD MODULE

L Q 0 7 0 Y 5 D G 0 6

DEVICE SPECIFICATIONS

CONTENTS

(1)	Summary	p3
(2)	Features	p3
(3)	Structure and module external	p3
(4)	Mechanical specifications	p3
(5)	I/O terminal name and functions	p4
(6)	Absolute maximum ratings	p6
(7)	Electrical characteristics	p7
(8)	Input signals, basic display color and gray scale of each color	p11
(9)	Optical characteristics	p12
(10)	Mechanical characteristics	p15
(11)	Display quality	p15
(12)	Handling instruction of TFT-LCD module	p15
(13)	Packing form	p18
(14)	Reliability test contents	p19
Fig.1	Outline dimensions	p20
Fig.2	Structure of TFT-LCD module	p21
Fig3-1	Timing characteristics of input signals	p22
Fig3-2	Timing characteristics of input signals	p23
Fig.4	Package form	p24
Appendix	Adjustment method of VCDC	p25

NOTICE

This publication is the proprietary of SHARP and is copyrighted, with all rights reserved. Under the copyright laws, no part of this publication may be reproduced or transmitted in any form or by any means, electronic or mechanical for any purpose, in whole or in part, without the express written permission of SHARP. Express written permission is also required before any use of this publication may be made by a third party.

The application circuit examples in this publication are provided to explain the representative applications of SHARP's devices and are not intended to guarantee any circuit design or permit any industrial property right or other rights to be executed.

SHARP takes no responsibility for any problems related to any industrial property right or a third party resulting from the use of SHARP's devices, except for those resulting directly from device manufacturing processes.

In the absence of confirmation by device specification sheets, SHARP takes no responsibility for any defects that occur in equipment using any of SHARP's devices, shown in catalogs, data books, etc. Contact SHARP in order to obtain the latest device specification sheets before using any SHARP's device.

SHARP reserves the right to make changes in the specifications, characteristics, data, materials, structures and other contents described herein at any time without notice in order to improve design or reliability. Contact SHARP in order to obtain the latest specification sheets before using any SHARP's device. Manufacturing locations are also subject to change without notice.

Observe the following points when using any device in this publication. SHARP takes no responsibility for damage caused by improper use of the devices.

The devices in this publication are designed for use in general electronic equipment designs , such as:

- Car Navigation system • Automotive auxiliary information display
- Automotive audio visual equipment

The appropriate design measures should be taken to ensure reliability and safety when SHARP's devices are used for equipment such as:

- Transportation control and safety equipment(i.e.,aircraft,trains,automobiles,etc.)
- Traffic signals • Gas leakage sensor breakers • Alarm equipment • Various safety devices etc.

SHARP's devices shall not be used for equipment that requires extremely high level of reliability, such as:

- Military and space applications • Nuclear power control equipment
- Medical equipment for life support

Contact a SHARP representative, in advance, when intending to use SHARP's devices for any "specific" applications other than those recommended by SHARP.

Contact and consult with a SHARP representative if there are any questions about the contents of this publication.

(1) Summary

This TFT-LCD module is a color active matrix LCD module incorporating amorphous silicon TFT. An outline of the module is given in Table 4-1.

(2) Features

- Utilizes a panel with a 15:9 aspect ratio, which makes the module suitable for use in wide-screen systems.
- The 7.0 screen produces a high resolution image that is composed of 384,000 pixels elements in a stripe arrangement.
- Graphics and texts can be displayed on a 800 × RGB × 480 dots panel with 262,144 colors by supplying 18 bit data signals(6 bit/color).
- Wide viewing field angle technology is employed.(The most suitable viewing angle is in the 6 o'clock direction.)
- By adopting an active matrix drive, a picture with high contrast is realized.
- Reduced reflection as a result of low reflection black matrix and an AG(antiglare) polarizer being adopted.
- By COG method, realized a slim, lightweight, and compact module.
- Transparent intensity is raised by adoption of the rate LCD panel of a high aperture, a high transparently color filter, and a high transparently polarizing plate.
- The quality picture of natural color reproducibility is realized by adoption in TN normally white mode excellent in color reproducibility.
- An inverted video display in the vertical and horizontal directions is possible.

(3) Structure and Outline Dimensions

Outline dimensions of the module are given in Fig.1.

Structure of the TFT-LCD module are given in Fig.2.

This TFT-LCD module is composed of the color TFT-LCD panel, driver ICs, FPC, frame, shielding front case and backlight unit.(circuit to drive the LEDbacklight is not built into this module.)

(4) Mechanical Specifications

Table4-1

Parameter	Specifications	Units	Remarks
Screen size (Diagonal)	17.7 [7.0"]	cm	
Active area	152.40(W) × 91.44(H)	mm	
Display format	800 × RGB(W) × 480(H)	dots	
Dot pitch	0.0635(W) × 0.1905(H)	mm	
Pixel configuration	R,G,B Stripe configuration		
Outline dimension	170.0(W) × 104.0(H) × 8.0(D)	mm	[Note4-1]
Mass	210 ± 15	g	

[Note4-1] Typical values are shown.

For detailed measurements and tolerances, please refer to Fig.1.
(FPC(LED/LCD),FPC fixation sheet are excepted.)

(5) I/O Terminal Name and Functions

5-1) TFT-LCD Panel Driving Part

Table5-1 I/O terminal name and functions

Pin No.	Symbol	i/o	Description	Remarks
1	GND	-	GND	
2	SPL	i / o	Start signal2 of Source driver	[Note5-1]
3	V10	i	The power supply of gray image	
4	V9	i	The power supply of gray image	
5	V8	i	The power supply of gray image	
6	V7	i	The power supply of gray image	
7	V6	i	The power supply of gray image	
8	V5	i	The power supply of gray image	
9	V4	i	The power supply of gray image	
10	V3	i	The power supply of gray image	
11	V2	i	The power supply of gray image	
12	V1	i	The power supply of gray image	
13	V0	i	The power supply of gray image	
14	VSHA	i	Power supply of Source driver	
15	VSHA	i	Power supply of Source driver	
16	GND	-	GND	
17	GND	-	GND	
18	R5	i	RED data signal (MSB)	
19	R4	i	RED data signal	
20	R3	i	RED data signal	
21	R2	i	RED data signal	
22	R1	i	RED data signal	
23	R0	i	RED data signal (LSB)	
24	GND	-	GND	
25	G5	i	GREEN data signal (MSB)	
26	G4	i	GREEN data signal	
27	G3	i	GREEN data signal	
28	G2	i	GREEN data signal	
29	G1	i	GREEN data signal	
30	G0	i	GREEN data signal (LSB)	
31	GND	-	GND	
32	B5	i	BLUE data signal (MSB)	
33	B4	i	BLUE data signal	
34	B3	i	BLUE data signal	
35	B2	i	BLUE data signal	
36	B1	i	BLUE data signal	
37	B0	i	BLUE data signal (LSB)	
38	LS	i	Date transfer signal of Source driver	
39	LBR	i	Change signal of direction of scan for source driver	[Note5-1]
40	GND	-	GND	
41	CK	i	Clock signal of Source driver	
42	GND	-	GND	
43	VSHD	i	Power supply of Source driver	
44	SPR	o / i	Start signal1 of Source driver	[Note5-1]
45	MODE1	i	Output mode setting signal 1 of gate driver	[Note5-2]
46	MODE2	i	Output mode setting signal 2 of gate driver	[Note5-2]
47	CLS	i	Clock signal of gate driver	
48	SPS	i	Start signal of gate driver	
49	U/L	i	Change signal of direction of scan for gate driver	[Note5-1]
50	GND	-	GND	

Pin No.	Symbol	i/o	Description	Remarks
51	VCOM	i	Common electrode driving signal	
52	VCOM	i	Common electrode driving signal	
53	CS	i	CS driving signal	
54	N.C.	-	OPEN	
55	VDD	i	Power supply of gate driver	
56	N.C.	-	OPEN	
57	VEE	-	Power supply of gate driver	
58	VCC	i	Power supply of gate driver	
59	N.C.	-	OPEN	
60	VSS	-	Power supply of gate driver	

[Note5-1] A vertical, horizontal direction of the scanning can be controlled according to this signal.

Table 5-2

Display mode	U/L	LBR	SPL	SPR
Normal displayed	Lo	Hi	Input mode	Output mode
Right/Left reverse mode	Lo	Lo	Output mode	Input mode
Up/Down reverse mode	Hi	Hi	Input mode	Output mode
Right/Left & Up/Down reverse mode	Hi	Lo	Output mode	Input mode

Caution) Lo=GND , Hi=VSHD

[Note5-2] The mode of the gate driver output can be selected by setting MODE1 and MODE2.

Table5-3

MODE1	MODE2	Output mode
Hi	Hi	Normal mode(1 line writing)
Lo	Hi	Out of use
Hi	Lo	2 line simultaneous writing mode
Lo	Lo	All output terminal is fixed at the VEE level.

Caution) Lo=GND , Hi=VSHD

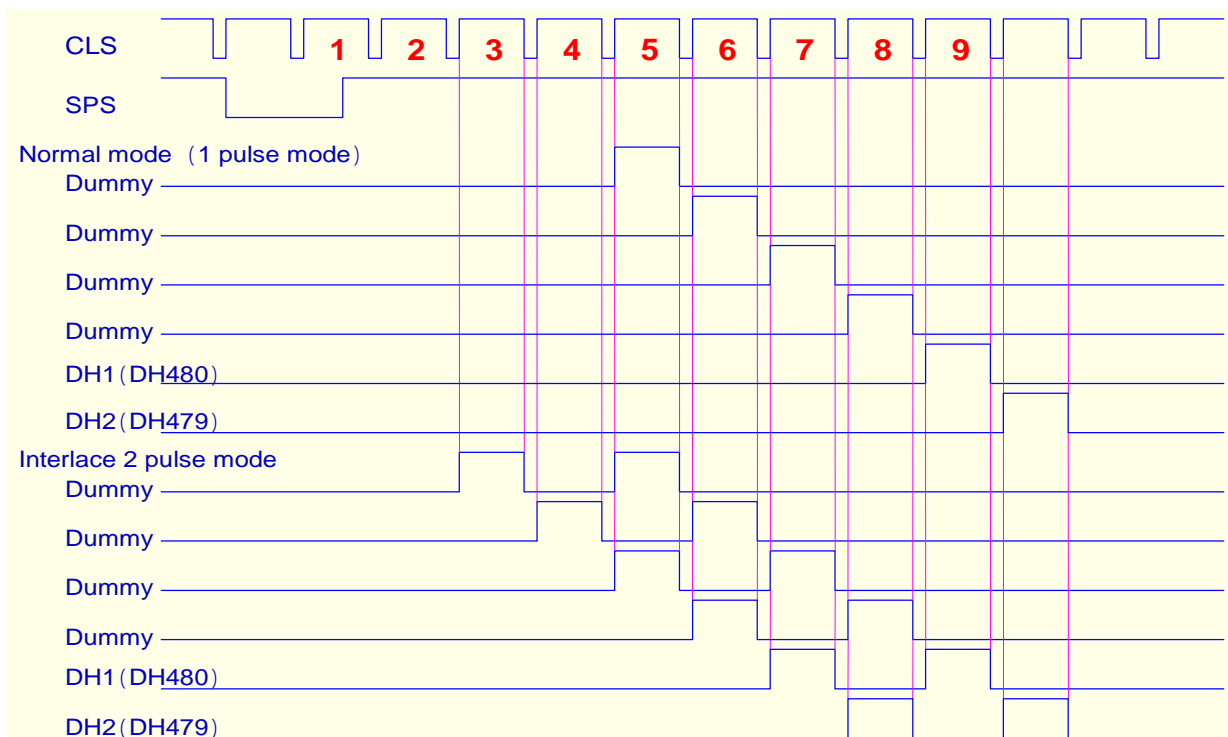

Fig.5-1 Gate output timing

5-2) Backlight fluorescent tube driving part

Table5-4

Pin No.	Symbol	Description	Remarks
1	A1	Input terminal (Anode 1)	
2	A2	Input terminal (Anode 2)	
3	NC		
4	K1	Input terminal (Cathode 1)	
5	K2	Input terminal (Cathode 2)	
6	K3	Input terminal (Cathode 3)	
7	NC		
8	NC		

(6) Absolute maximum ratings

Table6-1 Absolute maximum ratings

GND=0V

Parameter		Symbol	MIN	MAX	Unit	Remark
Power supply of source driver	Analog	VSHA	- 0.3	+6.0	V	Ta=25
	Digital	VSHD	- 0.3	+6.0	V	"
Power supply of gate driver		VDD	- 0.3	+35.0	V	"
		VCC - VSS	- 0.3	+6.0	V	"
		VEE - VSS	- 0.3	+35.0	V	"
		VDD - VEE(VSS)	- 0.3	+35.0	V	"
Input signal	Digital	VID	- 0.3	VSHD+0.3	V	" , [Note6-1]
	Analog	VIA	- 0.3	VSHA+0.3	V	" , [Note6-2]
Common electrode driving signal		VCOM	- 4	+6	V	"
Storage temperature		Tstg	- 40	85		[Note6-3,4]
Operating temperature (LCD panel surface)		Topr1	- 30	85		[Note6-5,6]
Operating temperature (Ambient temperature)		Topr2	- 30	65		[Note6-6]
Current of LED		If	-	150	mA	Ta=25

[Note6-1] SPL, SPR, R0 ~ R5, G0 ~ G5, B0 ~ B5, LS, CK, LBR, MODE1, MODE2, U/L, SPS, CLS

[Note6-2] V0, V1, V2, V3, V4, V5, V6, V7, V8, V9, V10

[Note6-3] This rating applies to all parts of the module and should not be exceeded.

[Note6-4] Maximum wet-bulb temperature is 57 . Avoid dew condensation on the module.

Otherwise electrical current leaks will occur , and it cannot meet the specifications.

[Note6-5] The operating temperature guarantees only operation of the circuit. For contrast, speed of response, and other factors related to display quality are determined in the circumstances with Ta= + 25 .

[Note6-6] Ambient temperature when the backlight is lit (reference value).

(7) Electrical Characteristics

7-1) TFT-LCD panel driving section

Table7-1 Recommended operating conditions

GND=0V, Ta=25

Parameter		Symbol	MIN	TYP	MAX	Unit	Remarks	
Power supply of source driver	Analog	VSHA	+5.0	+5.3	+5.6	V		
	Digital	VSHD	+2.5	+3.3	+3.6	V		
Power supply of gate driver	TFT driving	Hi	VDD	+14.8	+15.0	+15.2	V	
		Lo	AC	VEEAC	-	COM AC	-	V _{p-p} [Note7-1]
			DC	VEEDC	- 11.8	- 12.0	- 12.2	V
	Logic	Hi	VCC	VSS+VSHD - 0.3	VSS+VSHD	VSS+VSHD + 0.3	V	[Note7-2]
Lo		VSS	- 17.0	- 17.4	- 17.8	V		
Power supply of gray image		V0 ~ V10	0	-	VSHA	V	[Note7-3]	
Input voltage of source driver	Hi input	VIHS	0.8 × VSHD	-	VSHD	V	[Note7-4]	
	Lo input	VILS	GND	-	0.2 × VSHD	V		
Input current of source driver	Hi input	IIHS	-	-	10	μA	[Note7-4]	
	Lo input	IILS	-	-	10	μA		
Input voltage of gate driver	Hi input	VIHG	0.8 × VSHD	-	VSHD	V	[Note7-5]	
	Lo input	VILG	GND	-	0.2 × VSHD	V		
Input current of gate driver	Hi input	IIHG	-	-	1.0	μA		
	Lo input	IILG	-	-	1.0	μA		
Common electrode driving signal	A C component	COM AC	-	±3.6	±4.0	V _{p-p}	[Note7-6]	
	D C component	COM DC	+0.5	-	+2.5	V		
CS driving signal	A C component	VCSAC	-	±3.6	±4.0	V _{p-p}	[Note7-1]	
	D C component	VCSDC	- 5.3	- 5.5	- 5.7	V		

[caution] Notes when power supply is turned on.

Please do a power supply on and the power-off in a simultaneous each power supply or the following order. And, please input the signal after turning on all power supplies.

Turn on VSHD, VSHA, VSS, VCC → Logic signal, VEE → VDD → MODE1, MODE2

Turn off VDD → VEE, Logic signal (Include MODE1 and MODE2) → VCC, VSS, VSHA, VSHD

* Condition VSS < VCC

At the terminals of MODE1/MODE2 signals, input low voltage when applying the power supply, and hold low voltage for more than 2 vertical synchronous terms after VDD rises completely.

Then, either or both of them should hold high voltage until the power supply is turned off.

[Note7-1] This is must be made into common electrode driving signal, this phase, and this amplitude.

And please keep VSS = VEE.

[Note7-2] Condition: VSHD=3.3V

[Note7-3] It is a standard power supply for gray scale.

Whenever the polarity of common electrode drive signal (VCOM) is changed, please also change this standard voltage. V0 (black) power supply becomes the reverse characteristic of VCOM, and V10 (white) becomes the same polarity as VCOM. Please shift the center value of each power supply amplitude to the plus(+) direction according to the characteristic of liquid crystal as it will go to white side like V1, V2, V3, V4, V5, V6, V7, V8, V9, V10, if the center value of each power supply amplitude is based on the center value of V0 (black). After DC adjustment of VCOM signal is adjusted in case of the V0 gray scale display, please adjust this amount of shifts so that a flicker does not occur in the power supply display of each gray scale.

[Note7-4] Apply to terminal of R0 ~ R5,G0 ~ G5,B0 ~ B5,SPR,SPL,CK,LS and LBR.

[Note7-5] Apply to terminal of CLS,SPS,MODE1,MODE2 and U/L.

[Note7-6] Please switch polarity of amplitude COMAC by center value of amplitude that is COMDC for every one level scan and every one vertical scan. Moreover, please adjust COMDC so that contrast becomes the maximum and a flicker becomes the minimum for every module.

7-2) Backlight unit driving section

Table7-2

Parameter	Symbol	MIN	TYP	MAX	Unit	Remarks
LED voltage	Vf	16.0	17.3	21.3		Ta=25 ,If=90mA
LED voltage	Vf-30	-	-	22.8	V	Ta=-30 ,If=90mA
difference of lines of LED voltage	Vf	-	-	1.4	V	
LED current	If	-	90	95	mA	
Power consumption	Wf	-	5	-	W	

7-3) Timing characteristics of input signals

Timing diagrams of input signal are shown in Fig3-1, Fig3-2.

Table7-3

VSHA=5.3V,VSHD=3.3V,GND=0V,Ta=25

Parameter		Symbol	M I N	T Y P	M A X	Unit	Terminal
Source	Operating Clock frequency	fck	-	33.2	34.6	MHz	CK [Note7-7]
	High level clock width	Tcwh	12	-	-	ns	
	Low level clock width	Tcwl	13	-	-	ns	
	Clock rise time	Tcr	-	-	4	ns	
	Clock fall time	Tcf	-	-	4	ns	
	Start pulse frequency	fsp	-	31.5	31.8	kHz	SPR SPL [Note7-8]
	Start pulse set up time	Tsusp	4	-	-	ns	
	Start pulse hold time	Thsp	0	-	-	ns	
	Start pulse width	Twsp	1/fck	1/fck	1.5/fck	ns	
	LS pulse frequency	flp	-	fsp	-	kHz	LS
	LS pulse set up time (CLS)	Tsulp	5.0	-	-	μs	
	LS pulse set up time(SPL,SPR)	Tsulpsp	1/fck	-	-	ns	
	LS pulse hold time(DCLK)	Thlpck	20	-	-	ns	
	High level LS pulse wide	Twlp	1/fck	-	-	ns	
Data set up time	Tsud	15	-	-	ns	R0 ~ R5,G0 ~ G5,B0 ~ B5	
Data hold time	Thd	10	-	-	ns		
Gate	Operating Clock frequency	fcls	-	fsp	-	kHz	CLS
	Clock pulse with	Twl	5.5	-	-	μs	
	Clock rise time	Trcl	-	-	1/fck	ns	
	Clock fall time	Tfcl	-	-	1/fck	ns	
	Start pulse frequency	fsps	-	60	65	Hz	SPS
	Start pulse set up time	Tsusps	100	-	-	ns	
	Start pulse hold time	Thsps	300	-	-	ns	
	Start pulse rise time	Trsps	-	-	100	ns	
	Start pulse fall time	Tfsps	-	-	100	ns	
	COM signal set up time	Tsucom	3	-	-	μs	VCOM CS
COM signal hold time	Thcom	0	-	-	μs		
COM signal rise time	Trcom	-	-	2	μs		
COM signal fall time	Tfcom	-	-	2	μs		
V0 ~ V10 signal set up time	Tsuv0	3	-	-	μs	V0,V1,V2,V3, V4,V5,V6, V7,V8,V9,V10	
V0 ~ V10 signal hold time	Thv0	0	-	-	μs		
V0 ~ V10 signal rise time	Trv0	-	-	2	μs		
V0 ~ V10 signal fall time	Tfv0	-	-	2	μs		

[Note7-7] It is also possible that Tcr,Tcf exceeds the maximum value when the clock frequency doesn't reach the maximum value. But please confirm there is no problem.

[Note7-8] The rising pulse in CK is existed only 1 time during Hi period (Twsp) on start pulse.

7-4) Electric power consumption

Table7-4

Ta = 25

Parameter	symbol	Voltage condition	MIN	TYP	MAX	Unit	
Current for source driver	Analog	ISHA	VSHA=+5.3V	-	40	95	mA
	Digital	ISHD	VSHD=+3.3V		8.0	19	mA
Current for gate driver	Hi	IDD	VDD= + 15.0V	-	0.2	0.35	mA
	Lo	IEE	VEE= - 12.0 ± 3.6V	-	- 0.2	- 0.35	mA
	Logic Hi	ICC	VCC= - 14.1V	-	0.05	0.1	mA
	Logic Lo	ISS	VSS= - 17.4V	-	- 0.1	- 0.2	mA

*Conditions

Display pattern:

Vertical stripe pattern alternating 21 gray scale (GS21) with 42 gray scale (GS42) every 1 dot.

Driving condition:

fck = 33.2MHz, fsp = 30.3kHz, fsps = 60Hz, In case of using exclusive control-IC (LZ9JG17)

Other voltage conditions

VCOM=7.2Vp-p, V0=4.88Vp-p(The opposite phase of VCOM),

V10=3.04Vp-p(equal to phase of VCOM)

7-5) Input Data Signals and Display Position on the screen

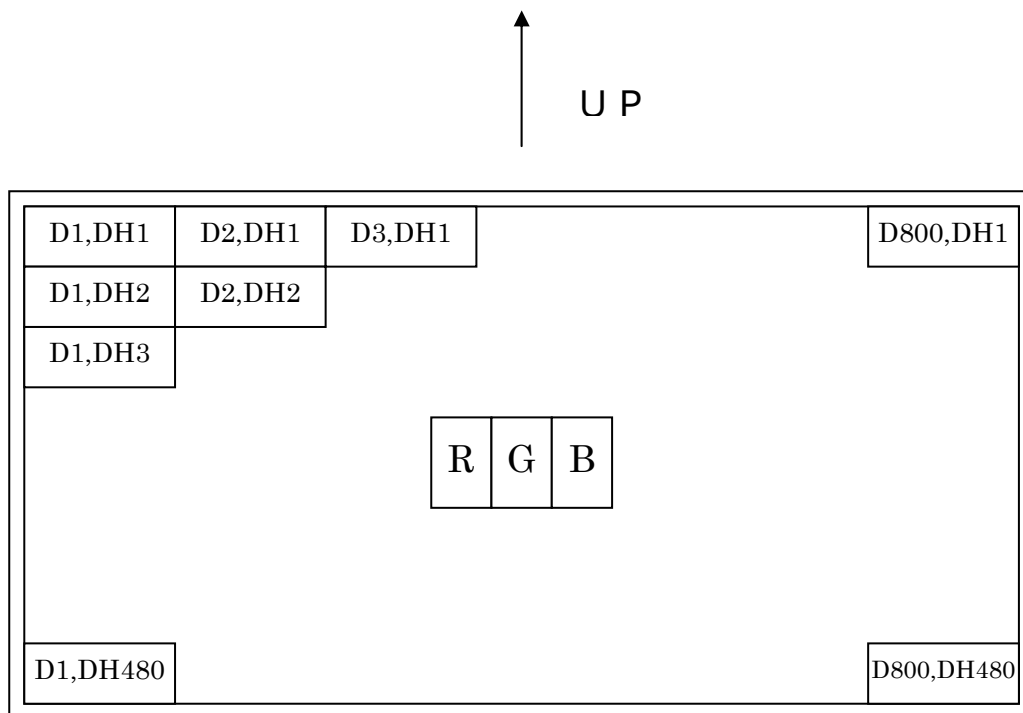

(8) Input signals, basic display color and gray scale of each color

Table8-1

Colors & Gray scale	Gray Scale	Data signal																		
		R0	R1	R2	R3	R4	R5	G0	G1	G2	G3	G4	G5	B0	B1	B2	B3	B4	B5	
Basic color	Black	-	0	0	0	0	0	0	0	0	0	0	0	0	0	0	0	0	0	0
	Blue	-	0	0	0	0	0	0	0	0	0	0	0	0	1	1	1	1	1	1
	Green	-	0	0	0	0	0	0	1	1	1	1	1	1	0	0	0	0	0	0
	Cyan	-	0	0	0	0	0	0	1	1	1	1	1	1	1	1	1	1	1	1
	Red	-	1	1	1	1	1	1	0	0	0	0	0	0	0	0	0	0	0	0
	Magenta	-	1	1	1	1	1	1	0	0	0	0	0	0	1	1	1	1	1	1
	Yellow	-	1	1	1	1	1	1	1	1	1	1	1	1	0	0	0	0	0	0
	White	-	1	1	1	1	1	1	1	1	1	1	1	1	1	1	1	1	1	1
Gray Scale of red	Black	GS0	0	0	0	0	0	0	0	0	0	0	0	0	0	0	0	0	0	0
	↑	GS1	1	0	0	0	0	0	0	0	0	0	0	0	0	0	0	0	0	0
	Darker	GS2	0	1	0	0	0	0	0	0	0	0	0	0	0	0	0	0	0	0
	↑	↓				↓					↓					↓				
	↓	↓				↓					↓					↓				
	Brighter	GS61	1	0	1	1	1	1	0	0	0	0	0	0	0	0	0	0	0	0
	↓	GS62	0	1	1	1	1	1	0	0	0	0	0	0	0	0	0	0	0	0
	Red	GS63	1	1	1	1	1	1	0	0	0	0	0	0	0	0	0	0	0	0
Gray Scale of green	Black	GS0	0	0	0	0	0	0	0	0	0	0	0	0	0	0	0	0	0	0
	↑	GS1	0	0	0	0	0	0	1	0	0	0	0	0	0	0	0	0	0	0
	Darker	GS2	0	0	0	0	0	0	0	1	0	0	0	0	0	0	0	0	0	0
	↑	↓				↓					↓					↓				
	↓	↓				↓					↓					↓				
	Brighter	GS61	0	0	0	0	0	0	1	0	1	1	1	1	0	0	0	0	0	0
	↓	GS62	0	0	0	0	0	0	0	1	1	1	1	1	0	0	0	0	0	0
	Green	GS63	0	0	0	0	0	0	1	1	1	1	1	1	0	0	0	0	0	0
Gray Scale of bleu	Black	GS0	0	0	0	0	0	0	0	0	0	0	0	0	0	0	0	0	0	0
	↑	GS1	0	0	0	0	0	0	0	0	0	0	0	0	1	0	0	0	0	0
	Darker	GS2	0	0	0	0	0	0	0	0	0	0	0	0	0	1	0	0	0	0
	↑	↓				↓					↓					↓				
	↓	↓				↓					↓					↓				
	Brighter	GS61	0	0	0	0	0	0	0	0	0	0	0	0	1	0	1	1	1	1
	↓	GS62	0	0	0	0	0	0	0	0	0	0	0	0	0	1	1	1	1	1
	Bleu	GS63	0	0	0	0	0	0	0	0	0	0	0	0	1	1	1	1	1	1

0 : Low level voltage 1 : High level voltage

Each basic color can be displayed in 64 gray scales from 6 bit data signals. According to the combination of total 18 bit data signals, the 262,144-color display can be achieved on the screen.

(9) Optical characteristics

Table9-1

Ta=25

Parameter	Symbol	Condition	MIN	TYP	MAX	Unit	Remarks	
Viewing angle range	Horizontal	θ21, θ22	CR 10	50	60	-	°(degree)	[Note9-1]
	Vertical	θ11		45	55	-	°(degree)	
		θ12		35	50	-	°(degree)	
Contrast ratio	CRmax	θ = 0°	150	310	-		[Note9-2]	
Response time	Rise time	τr	θ = 0°	-	9		ms	[Note9-3]
	Fall time	τd		Ta=25	-	17		
	Rise time	τr	Tp=-20	-	35	50	ms	
	Fall time	τd		-	80	100	ms	
Panel surface brightness	Y0	If=90mA (at LED 1line) (no signal input)	400	540	-	cd/m ²	[Note9-4]	
Panel surface chromaticity	no impression	x	If=90mA (at LED 1line)	0.257	0.307	0.357		[Note9-5]
		y		0.268	0.318	0.368		
LED lifetime	+25	-	continuation	10,000	-	-	Hour	[Note9-6]

*Measured after 30minutes operation. The optical characteristic is measured by using the method of fig.10-1 and fig.10-2 under the condition of the darkroom or equivalent to it.

Conditions

VCOM=7.2Vp-p, V0=4.88Vp-p(The opposite phase of VCOM),

V10=3.04Vp-p(equal to phase of VCOM)

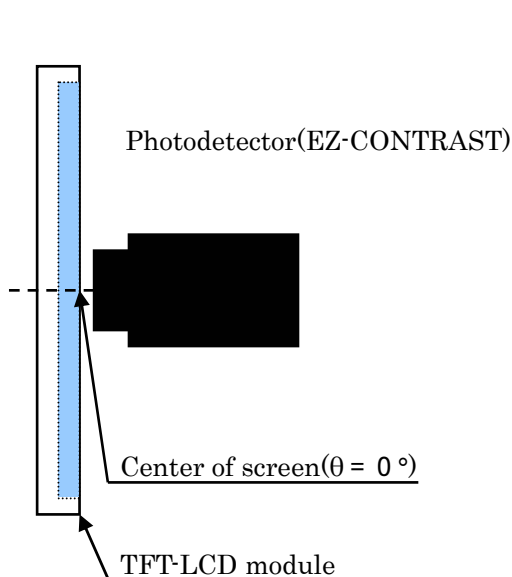

Fig.10-1 Viewing angle / Range / Contrast / Response time measurement method

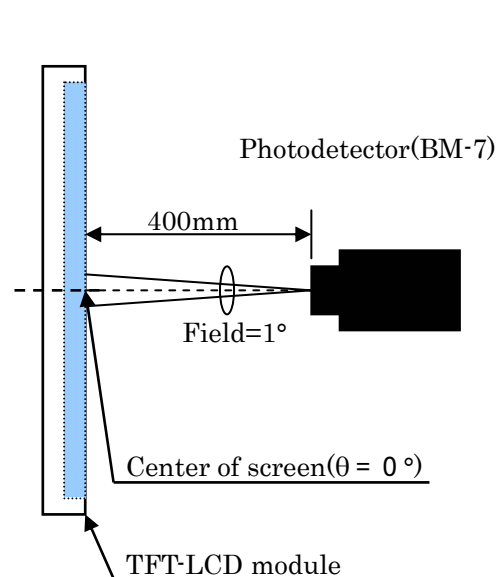
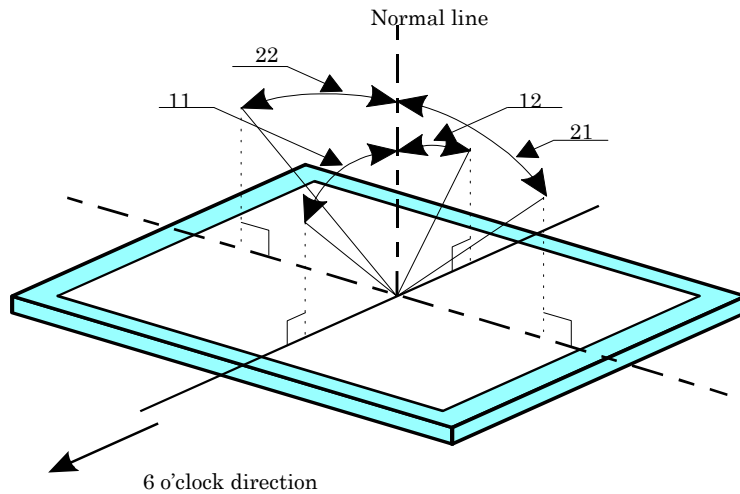

Fig.10-2 Luminance / Chromaticity measurement method

[Note 9-1] Viewing angle range is defined as follows.



[Note 9-2] Contrast ratio is defined as follows:

$$\text{Contrast ratio(CR)} = \frac{\text{Photo detector output with LCD being "white(GS63)"}}{\text{Photo detector output with LCD being "black(GS0)"}}$$

[Note 9-3] Response time is defined as follows:

Response time is obtained by measuring the transition time of photo detector output, when input signals are applied so as to make the area "black" to and from "white".

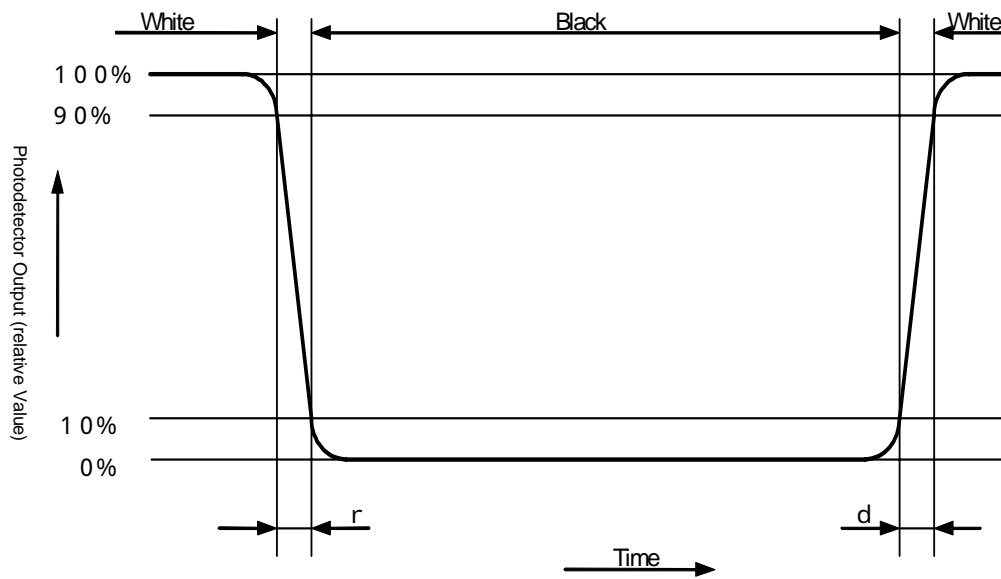

[Note 9-4] Definition of panel surface brightness

Measured on the center area of the panel at a viewing cone 1-degree by TOPCON luminance meter BM-7.(After 30 minutes operation)

[Note 9-5] Definition of panel surface chromaticity

Measured on the center area of the panel at a viewing cone 1-degree by TOPCON luminance meter BM-7.(After 30 minutes operation) $I_f=90\text{mA}$ at LED 1line

[Note 9-6] LED life time (continuous lighting)

Lamp life time is defined as the time when the center brightness of LCD module becomes 50% of the following conditions.

$I_f = 90\text{mA}$ (at LED 1line)

PWM brightness control : 5 ~ 100%

(10) Mechanical characteristics

10-1) External appearance

Do not exist extreme defects. (See Fig. 1)

10-2) Panel toughness

The panel should not be broken, when press to the center of the panel by 19N power using smooth surface with 15mm diameter.

Caution: If the pressure is added on the active area of the panel over the long time, even if the pressure is very small weight, the functional damage might occur in the panel.

10-3) I/O connector performance

A) Input/output connectors to control the LCD module

1) Applicable Connector : FH28 - 60S - 0.5SH (HIROSE)

2) FPC flexibility : Slit on the film cover lay coat part of one side printing.

If it had been tested bending under radius nothingness and bending angle 180degrees, the FPC should not be cut. (It should be bend by hand and only at once.)

The film cover lay coat part of one side printing.

Do not disconnect by 30 times or less after examining the winding on the following conditions.

condition : winding radius 0.6mmR and condition of 90° in winding angle

B) I/O connector of backlight driving circuit

1) Corresponding connector : CFP1508-0101F (SMK)

2) FPC flexibility : The same as A) Input/output connectors to control the LCD module

(11) Display quality

The display quality of the color TFT-LCD module is applied to the Incoming Inspection Standard.

(12) Handling instruction of TFT-LCD module

12-1) Handling of FPC

Please bend FPC only at the film cover lay slit part of one side printing or the film cover lay coat part of one side printing.

Please do not hang a LCD module or do not apply excessive power for FPC.

12-2) Installation of TFT-LCD module

When incorporating the TFT-LCD module, be sure to fix the module on the same plane, and be careful not to add the stress of wraps or twists to the module.

Do not add the pressure to the module by force of pushing parts on the set side (touch-switches, etc.) directly, otherwise display images may be disordered.

Attachment of input/output FPC and removal should surely turn off the power supply of a set.

12 - 3) Precautions in mounting

Polarizer adhering to the surface of the LCD is made of a soft material and susceptible to flaw, it must be handled carefully. Protection sheet is applied on the surface to protect. It against scratches and dirties. It is recommended to remove the protection sheet immediately before the use, taking care of static electricity.

Precautions in removing the protection sheet

A) Work environment

When the protection sheet is removed off, static electricity may cause dust to stick to the polarizer surface. To avoid this, the following working environment is desirable.

- a) Floor : Conductive treatment of $1M\Omega$ or more on the tile.
(conductive mat or conductive paint on the tile)
- b) Clean room free form dust and with an adhesive mat on the doorway
- c) Advisable humidity:50% ~ 70% Advisable temperature:15 ~ 27
- d) Workers shall wear conductive shoes, conductive work clothes, conductive gloves and an earth band.

B) Working procedures

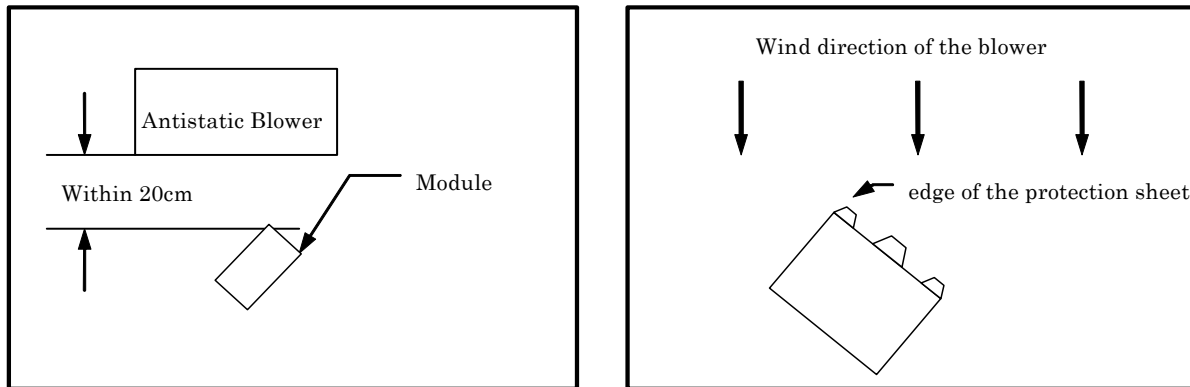

- a) Direct the wind of discharging blower somewhat downward to ensure that module is blown sufficiently. Keep the distance between module and discharging blower within 20 cm.
- b) Attach edge of the protection sheet part near discharging blower so as to protect polarizer against flaw.
- c) Remove the protection sheet , pulling edge of the protection sheet slowly to your side.
- d) On removing off the protection sheet, pass the module to the next work process to prevent the module to get dust.
- e) Method of removing dust from polarizer
 - Blow off dust with N2 blower for which static electricity preventive measure has been taken.
 - Since polarizer is vulnerable, wiping should be avoided.

But when the panel has stain or grease, we recommend using adhesive tape to softly remove them from the panel.

When metal part of the TFT-LCD module (shielding case) soiled, wipe it with soft dry cloth.

For stubborn dirt, wipe the part after breathing on there. For water drops or finger grease, wipe off immediately. Long contact with water may cause discoloration or spots.

TFT-LCD module uses glass which breaks or cracks easily if dropped or bumped on hard surface. Handle with care. The LCD used in the module is made of glass. If drop the module or bump it on hard surface, the LCD should be broken.

Since CMOS LSI is used in this module, take care of static electricity and earth your body when handling the module.

12-4) Caution of product design

Protect the LCD module from water/salt-water by the waterproof cover, etc.

Take measures against electromagnetic shield so that interferential radiation from the module should not affect peripheral appliances.

12-5) Other

Do not expose the module to direct sunlight or intensive ultraviolet rays for many hours. Liquid crystal is deteriorated by ultraviolet rays.

Store the module at a temperature near the room temperature. At lower than the rated storage temperature, liquid crystal solidifies, causing the panel to be damaged. At higher than the rated storage temperature, liquid crystal turns into isotropic liquid and may not recover.

If LCD panel breaks, there may be a possibility that the liquid crystal escapes from the panel.

Since the liquid crystal is injurious, do not put it into the eyes or mouth. When liquid crystal sticks to hands, feet or clothes, wash it out immediately with soap.

Be sure to adjust DC bias voltage of common electrode driving signal(COM DC) in the state of the last product. When not adjusted, it becomes the cause of a deterioration of display quality.

Observe all precautionary requirements of general electronic components.

(13) Package form

13-1) Package form (Refer to Fig.4)

13-2) Carton keeping conditions

The cartons can be piled up maximum 10 layers.

Environments

Temperature : 0 ~ 40

Humidity : 60%RH or less(at 40)

No dew condensation at low temperature and high humidity.

Atmosphere : Harmful gas such as acid or alkaline that bites electronic components or wires, must not be detected.

Periods : About 3 months

Opening of the package : In order to prevent the LCD module from breakdown by electrostatic charges, please control the humidity over 50%RH and open the package taking sufficient countermeasures against electrostatic charges, such as earth, etc.

(14) Reliability test contents

The reliability test condition of This LCD module is shown in Table 14-1.

(15) Other

15-1) Indication of the lot number

The lot number is shown on a label. Attached location is shown in Fig.1 (Outline Dimensions).

Indicated contents of the label :

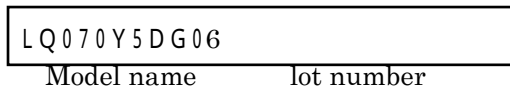

Contents of the lot number

the 1st figure	production year	ex. 2008	8
the 2nd figure	production month	1,2,3, ,9,X,Y,Z	
the 3rd ~ 8th figure	serial number	0 0 0 0 0 1 ~	
the 9th figure	revision marks	Blank,A,B,C ...	

Table 14-1 Reliability test conditions

Table 12 Temperature condition is based on operating temperature condition

No.	Test items	Test condition
1	High temperature strong test	Ta = +85 240h
2	Low temperature strong test	Ta = - 40 240h
3	High temperature and high humidity operation test	Tp = +60 , 90%RH 240h
4	Hi temperature operating test	Tp = +85 240h
5	Low temperature operating test	Ta = - 30 240h
6	Electro static discharge test	±200V · 200p F (0Ω) 1 time for each terminals
7	Shock test	980m/s ² · 6ms , ±X ; ±Y ; ±Z 3 times for each direction (JIS C0041, A-7 Condition C) 【caution】
8	Vibration test	Frequency : 8 ~ 33.3Hz , Stroke : 1.3mm Frequency : 33.3Hz ~ 400Hz, Acceleration : 29.4m/s ² Cycle : 15 minutes X, Z 2 hours for each directions , 4 hours for Y direction (total 8 hours) 【caution】 (JIS D1601)
9	Heat shock test	- 30 ~ +85 / 200 cycles (0.5 h) (0.5 h)

【Note】 Ta = Ambient temperature, Tp = Panel temperature

【Check items】 In the standard condition, there shall be no practical problems that may affect the display function.

【caution】 Definition of X , Y , Z direction is shown as follows

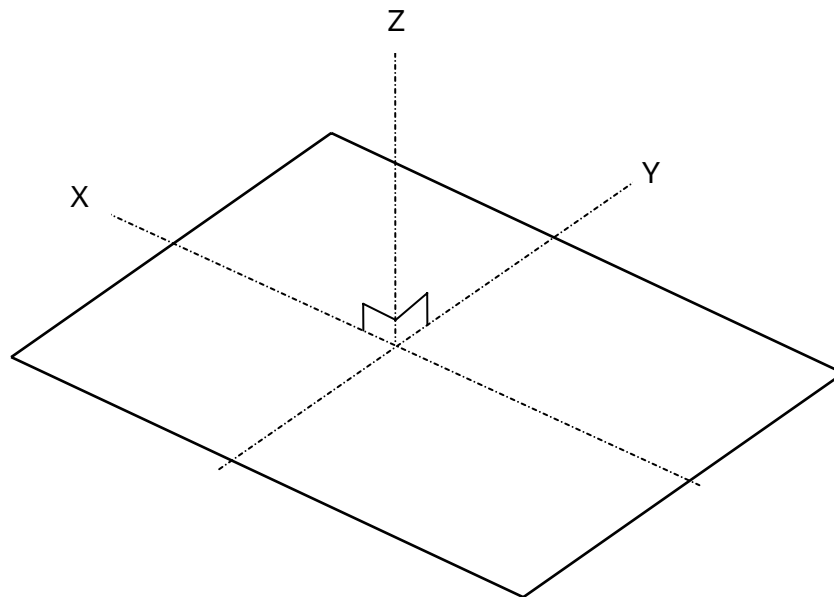

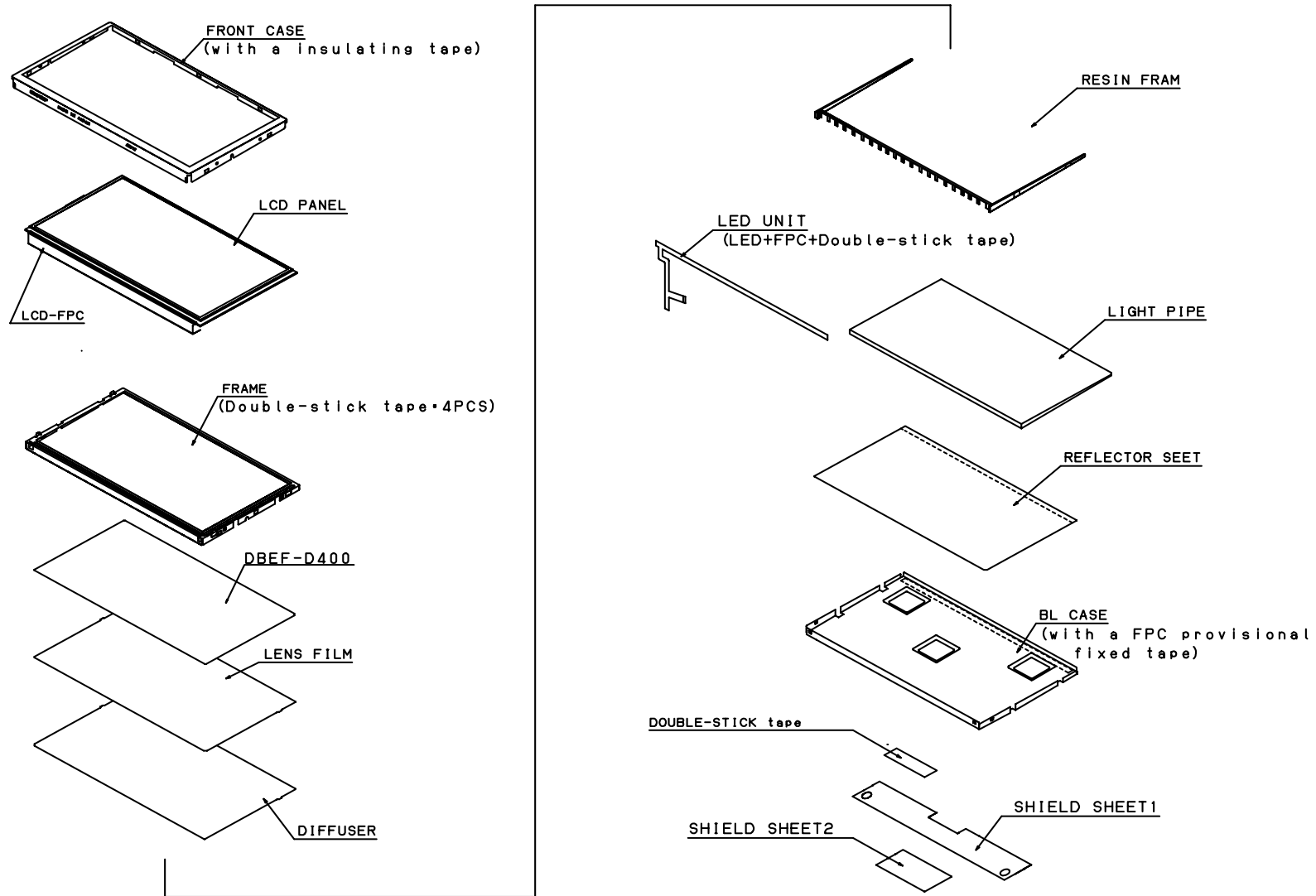

Fig2.Assembly form figure

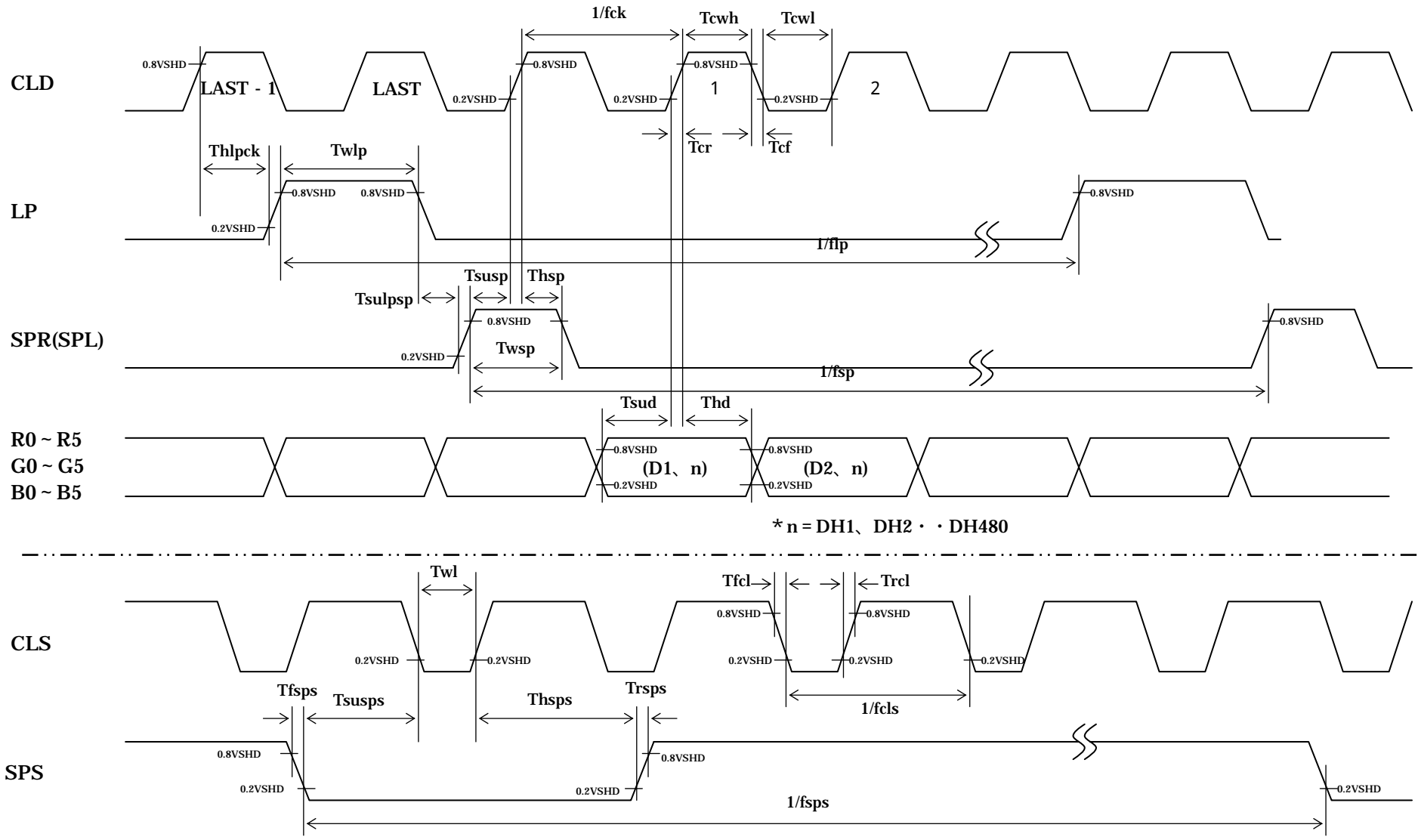

Fig.3-1. Input signal waveform

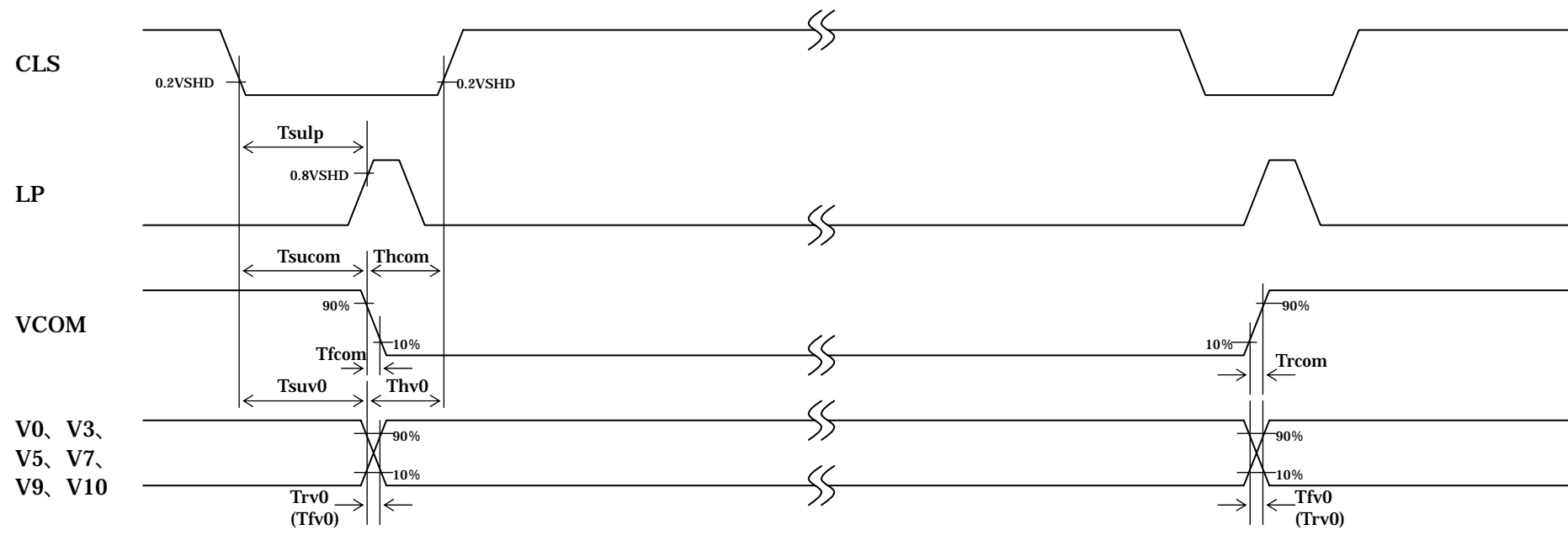
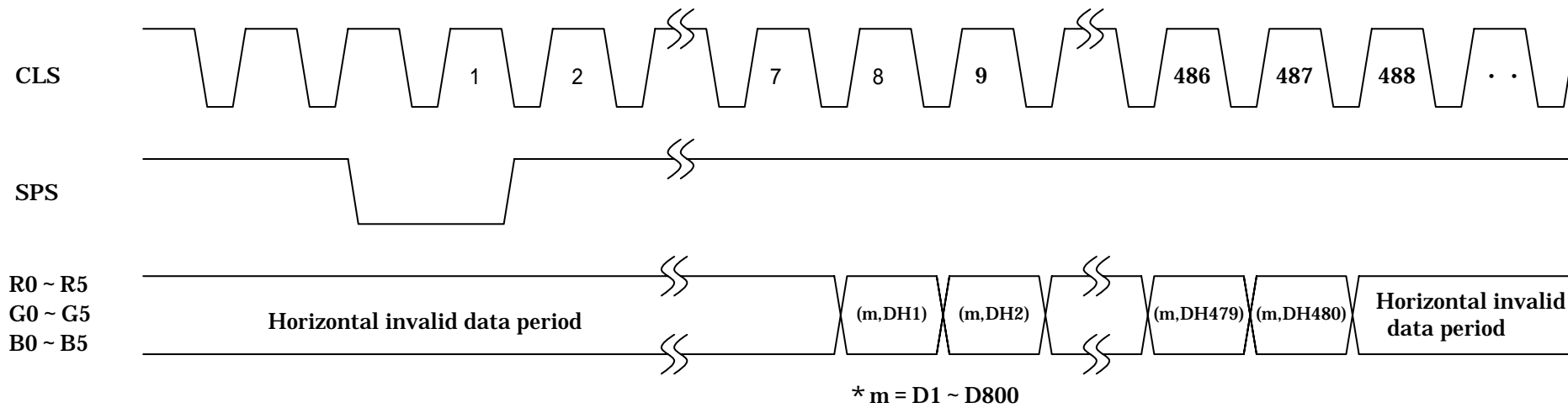
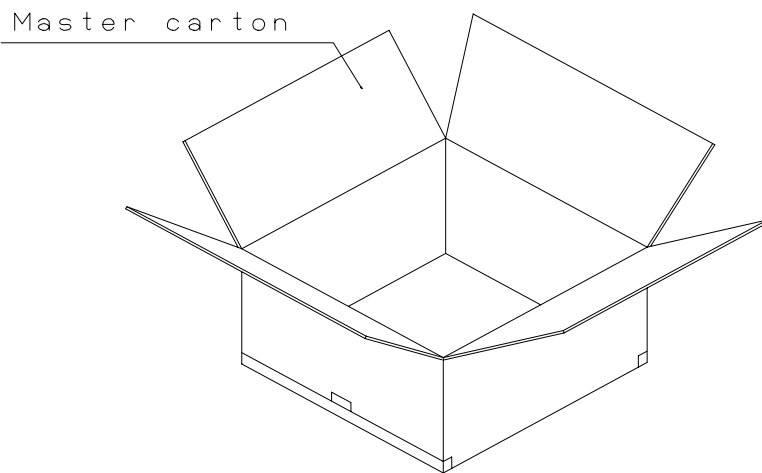
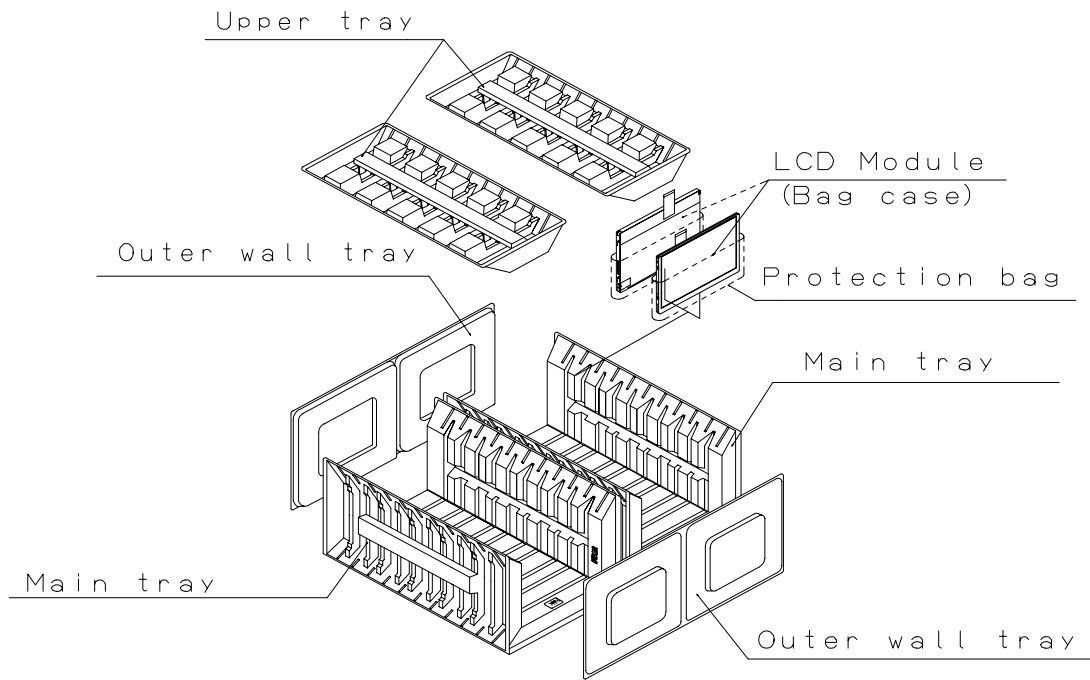

Fig.3-2. Input signal waveform



Maximum 20 units per 1 carton

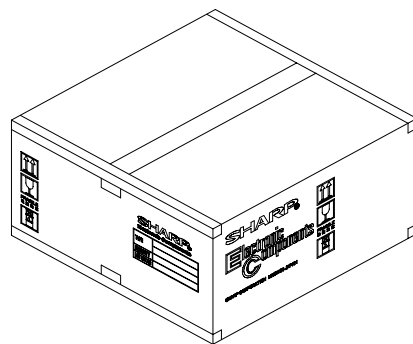

Fig4.Packing form figure

(Appendix)

Adjusting method of optimum DC bias voltage of common electrode driving signal

Photoelectric devices are very effective to obtain optimum DC bias voltage of common electrode driving signal accurately, and the accuracy is with 0.1V. (In visual examination method, the accuracy is about 0.5V because of the difference among individuals.)

Adjusting method of DC bias voltage using the photoelectric devices is as follows

Measurement of flicker

Adjust the DC bias voltage so as to minimize flicker at NTSC : 60Hz(30Hz) / PAL : 50Hz(25Hz).

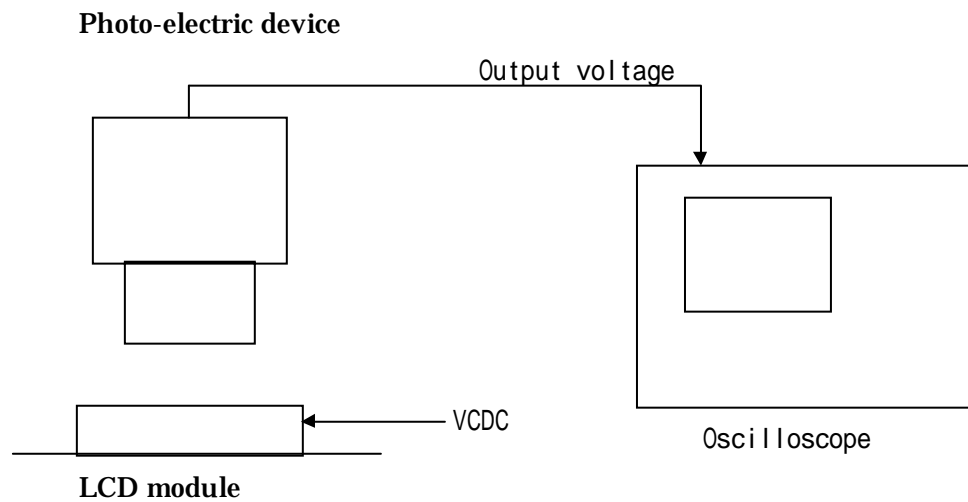

Fig. A Measurement system

Adjusting method of DC bias voltage

Measure the output voltage from Photoelectric device using the oscilloscope at the measurement system of Fig. A.

Then, change the DC bias voltage in small steps, and adjust it so as to minimize the flicker at NTSC 60Hz(30Hz) / PAL : 50Hz(25Hz). (Fig.B)

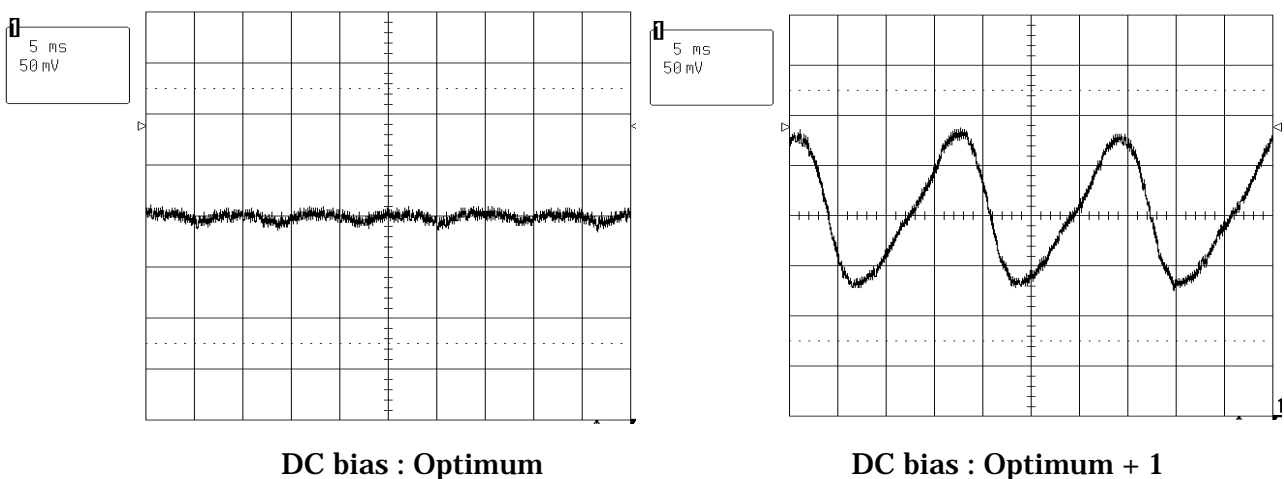

Fig. B Waveforms of flicker