

PREPARED BY : DATE

APPROVED BY : DATE

S H A R P

TFT LIQUID CRYSTAL DISPLAY GROUP
SHARP CORPORATION

S P E C I F I C A T I O N

SPEC No. LCY-99174

FILE No.

ISSUE : Nov. 26. 1999

PAGE : 6 pages

APPLICABLE GROUP
TFT LIQUID CRYSTAL DISPLAY
GROUP

DEVICE SPECIFICATION FOR

LAMP UNIT

MODEL No. LQ0B192

CUSTOMER'S APPROVAL

DATA _____

BY _____



PRESENTED

BY S. Yasuda

S. YASUDA
DEPARTMENT GENERAL MANAGER
DEVELOPMENT ENGINEERING DEPT. II
TFT DIVISION I
TFT LIQUID CRYSTAL DISPLAY GROUP
SHARP CORPORATION

(1) Subject

This literature is applied for LQ0B192 which is the lamp unit for 26cm(10.4") TFT-LCD module.

- > These specification sheets are the proprietary product of SHARP CORPORATION (SHARP) and include materials protected under copyright of SHARP. Do not reproduce or cause any third party to reproduce them in any form or by any means, electronic or mechanical, for any purpose, in whole or in part, without the express written permission of SHARP.
- > The device listed in these specification sheets was designed and manufactured for use in FA equipment.
- > In case of using the device for applications such as control and safety equipment for transportation (aircraft, trains, automobiles, etc.), rescue and security equipment and various safety related equipment which require higher reliability and safety, take into consideration that appropriate measures such as fail-safe functions and redundant system design should be taken.
- > Do not use the device for equipment that requires an extreme level of reliability, such as aerospace applications, telecommunication equipment(trunk lines), nuclear power control equipment and medical or other equipment for life support.
- > SHARP assumes no responsibility for any damage resulting from the use of the device which does not comply with the instructions and the precautions specified in these specification sheets.

Contact and consult with a SHARP sales representative for any questions about this device.

(2) Introduction

This lamp unit is a service part for 26cm TFT-LCD module (LQ10D41/42/421/41K) whose backlight is designed to be replaceable and exactly same as originally installed one for above models.

(3) Construction and Outline

The unit is composed of 2 unit of cold cathode fluorescent tubes, I/O wires (including connectors), and lamp holders.

* Outline drawing of lamp unit : See Fig. 1.

(4) Input / Output terminals

4-1) I/O terminal order

Table 1

Pin No.	Symbol	i/o	Description	Wire color
1	VHIGH	i	Power supply for lamp (High voltage side)	Pink
2	NC	-	No connection	-
3	VLOW	i	Power supply for lamp (Low voltage side)	White

4-2) I/O connector

1) Used housing : BHR-03VS-1

2) Mating connector : SM02(8.0)B-BHS

(produced by Japan Solderless Terminal)

(5) Electrical characteristics

6-2. Backlight driving

The backlight system is an edge-lighting type with double CCFT (Cold Cathode Fluorescent Tube).

The characteristics of single lamp are shown in the following table.

Ta=25°C

Parameter	Symbol	Min.	Typ.	Max.	Unit	Remark
Lamp current	IL	2.0	6.0	6.5	mA	【Note1】
Lamp power consumption	PL	—	3.0	—	W	
Lamp frequency	FL	20	35	60	KHz	【Note2】
Kick-off voltage	Vs	—	—	950	Vrms	Ta=25°C
		—	—	1400	Vrms	Ta=0°C 【Note3】
Lamp life time	LL	—	50000	—	hour	【Note4】

【Note1】 Lamp current is measured with current meter for high frequency as shown below.

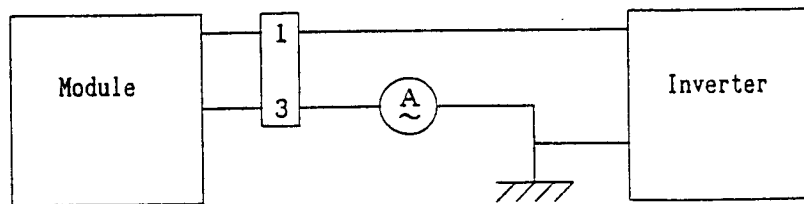

* 3pin is V_{LOW}

【Note2】 Lamp frequency may produce interference with horizontal synchronous frequency, and this may cause beat on the display. Therefore lamp frequency shall be detached as much as possible from the horizontal synchronous frequency and from the harmonics of horizontal synchronous to avoid interference.

【Note3】 The open output voltage of the inverter shall be maintained for more than 1sec, otherwise the lamp may not be turned on. And the level of the voltage shall be maintained until both lamps are turned on.

【Note4】 a) Since lamp is consumables, the life time written above is referencial value and it is not guaranteed in this specification sheet by SHARP.

Lamp life time is defined that it applied either ① or ② under this condition
(Continuous turning on at $T_a=25^{\circ}\text{C}$, $I_L=6\text{mA rms}$)

① Brightness becomes 50% of the original value under standard condition.

② Kick-off voltage at $T_a=0^{\circ}\text{C}$ exceeds maximum value, 1400 Vrms.

b) In case of operating under lower temp environment, the lamp exhaustion is accelerated and the brightness becomes lower.

(Continuous operating for around 1 month under lower temp condition may reduce the brightness to half of the original brightness.)

In case of such usage under lower temp environment, periodical lamp exchange is recommended.

Note) The performance of the backlight, for example life time or brightness, is much influenced by the characteristics of the DC-AC inverter for the lamp. When you design or order the inverter, please make sure that a poor lighting caused by the mismatch of the backlight and the inverter (miss-lighting, flicker, etc.) never occur. when you confirm it, the module should be operated in the same condition as it is installed in your instrument.

(6) Optical characteristics

Table 3

$T_a=25^{\circ}\text{C}$

Parameter	Symbol	MIN.	TYP.	MAX.	Unit	Remarks
Luminance	YL	24,300	27,000	29,700	cd/m ²	
Chromaticity	X	-	0.293	-		
	Y	-	0.263	-		

Above value is the characteristics of the lamp itself with the inverter
(CXA-M10L-L) made by TDK.

LD8706-3

(7) Environmental condition

Item	Symbol	Temperature	Unit	Remarks
Storage temperature range	Tstg	-25 - +70	°C	Note 1
Operating temperature range (Ambient)	Topa	0 - +55	°C	

【Note1】 Humidity : 95%RH Max. at $T_a \leq 40^{\circ}\text{C}$.

Maximum wet-bulb temperature at 39°C or less at $T_a > 40^{\circ}\text{C}$.

No condensation.

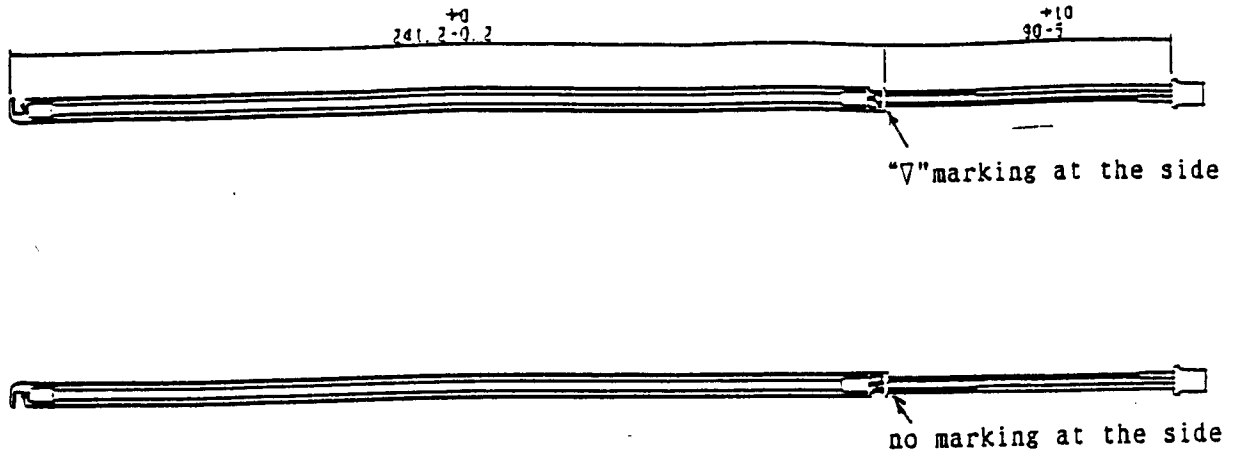

Fig. 1. Outline drawing of lamp unit

(8) Procedure to exchange lamp unit

Lamps for the LCD module can be worn out , so please replace them to new lamps when needed in accordance with the following ①~③ procedure.

Make sure that power is off before you replace them to prevent you from getting an electric shock.

- ① The latch for holder can be loosened by pushing the black color click portion with small minus shaped screw driver. The click is located at the side of the holder.

Loosening the latch , draw the lamp holder the "B" direction.

(refer to the Fig.2 and Fig.3)

- ② The new lamp holder as a spare parts should be distinguished between up side and bottom side and upper side one has a marking of "▽" at the side of the holder .

And also module side has the same marking at the upper side of the module. Please take care the marking direction in accordance with following figure.

Insert both lamp holders to the direction "C" and confirm it inserted completely with click .

(refer to the Fig.3)

- ③ Not only one side ,both lamps should be exchanged.

(9) Packing form

Packing form is shown in Fig.4

(10) Others

If any problem occurs in relation to the description in the present specifications or other relevant items, it shall be eliminated in all sincerity through discussion.

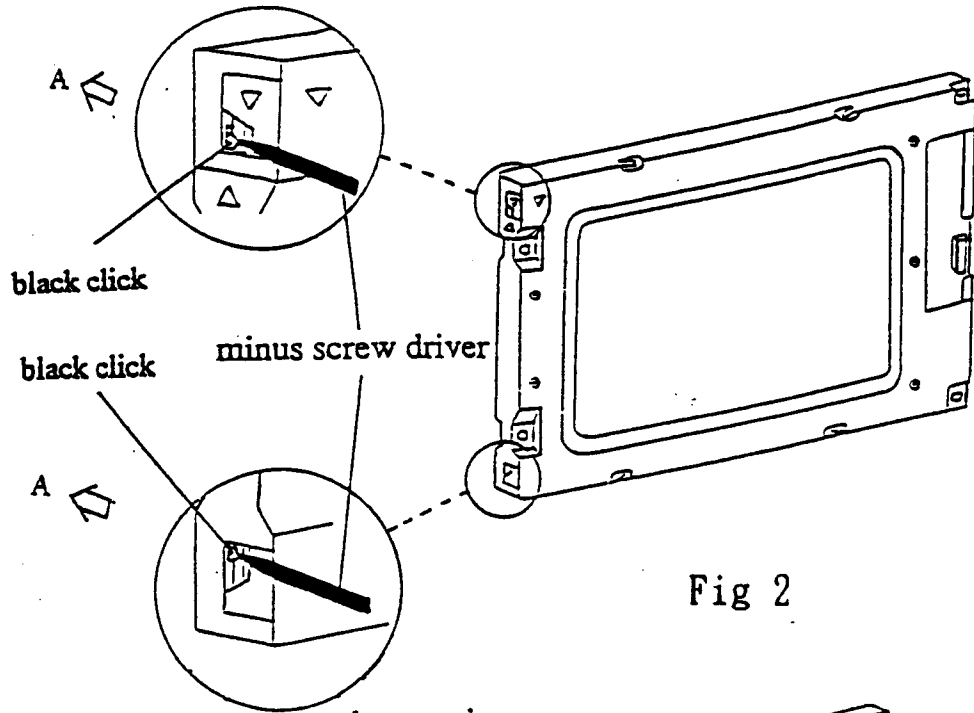

Fig 2

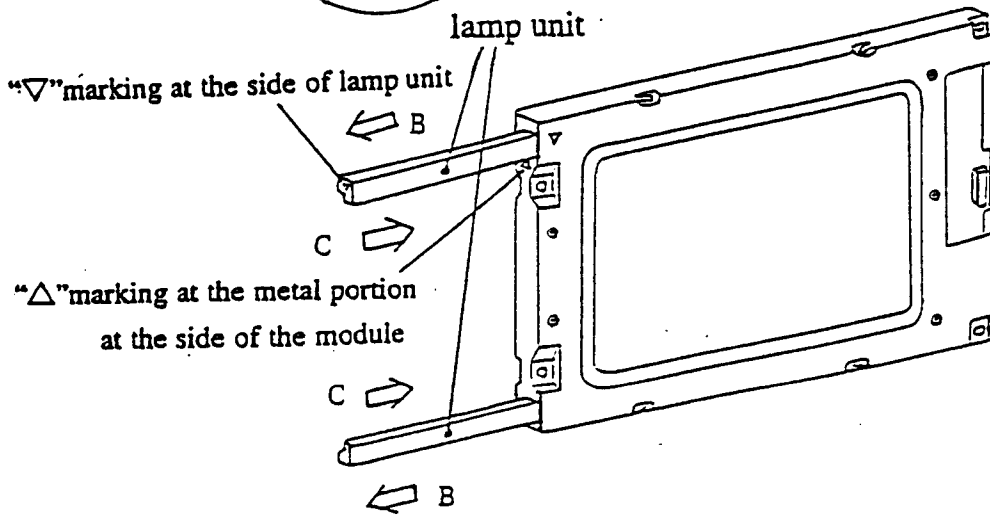
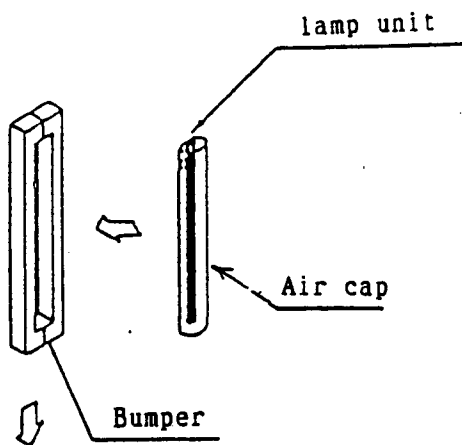
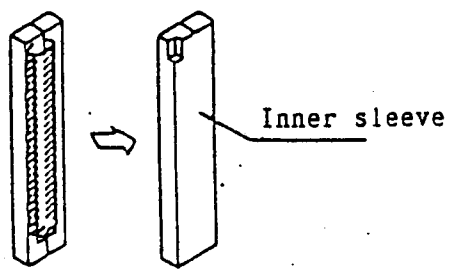

Fig 3



Pack the lamp unit in the air cap, and put it in the bumper.



Put the bumper in the inner sleeve.

A and B are printed on the outer carton

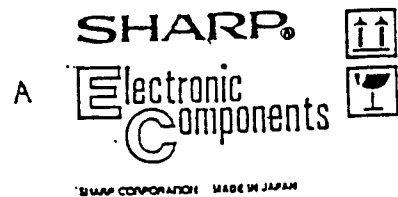
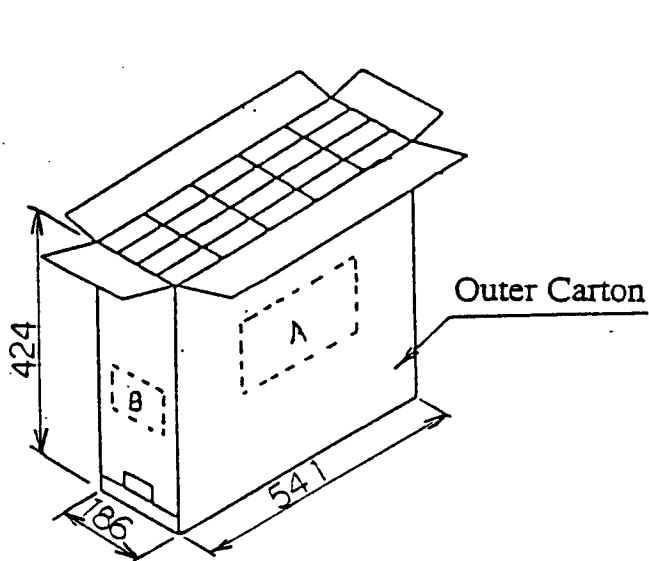

B

SHARP®	
Electronic Components	
TYPE	LQ0B192
QUANTITY	20 組 (40本)
LOT (DATE)	

1 carton contains 20 sets(40 pieces).

Fig 4 Packing form