

SPEC No. LD-19Y12A

ISSUE : Nov. 26. 2007

PAGE:15 pages

DEVICE SPECIFICATION FOR

TFT-LCD Module

MODEL No.

LQ0DZA0147

**106K1LA01C

In case of using the device for applications such as control and safety equipment for transportation(aircraft, trains, automobiles, etc.), rescue and security equipment and various safety related equipment which require higher reliability and safety, take into consideration that appropriate measures such as fail-safe functions and redundant system design should be taken.

Do not use the device for equipment that requires an extreme level of reliability, such as aerospace applications, telecommunication equipment(trunk lines), nuclear power control equipment and medical or other equipment for life support.

This specification sheets sheet is to guarantee the quality of the LCD module itself, only Should you need to evaluate and confirm the performance of the module, please do so when the LCD module is assembled into your finished product.

Table of contents

1. Application	3
2. Overview	3
3. Mechanical Specifications	3
4. Input Terminals	4
4-1. TFT-LCD panel driving	4
4-2. Interface block diagram	5
4-3. Backlight driving	6
5. Absolute Maximum Ratings	6
6. Electrical Characteristics	6
6-1. TFT-LCD panel driving	6
6-2. Backlight driving	8
7. Timing Characteristics of Input Signals	9
7-1. Timing characteristics	10
7-2. Display position	10
7-3. Input data signals and display position on the screen	10
8. Input Signals, Basic Display Colors and Gray Scale of Each Color	11
9. Optical Characteristics	12
10. Handling Precautions	14
11. Packing Form	14
Fig.1 Outline Dimensions	15

1. Application

This specification applies to a color TFT-LCD module, LQ0DZA0147.

2. Overview

This module is a color active matrix LCD module incorporating amorphous silicon TFT (Thin Film Transistor). It is composed of a color TFT-LCD panel, driver ICs, control circuit and power supply circuit and a backlight unit. Graphics and texts can be displayed on a $1280 \times 3 \times 768$ dots panel with 262,144 colors by using LVDS (Low Voltage Differential Signaling) to interface and supplying +3.3V DC supply voltage for TFT-LCD panel driving and supply voltage for backlight.

In this TFT-LCD panel, low reflection / color filters of excellent color performance and backlights of high brightness are incorporated to realize brighter and clearer pictures, making this model optimum for use in multi-media applications.

Optimum viewing direction is 6 o'clock.

Backlight-driving DC/AC inverter is not built in this module.

3. Mechanical Specifications

Parameter	Specifications	Unit
Display size	27(10.6") Diagonal	cm
Active area	230.40 (H) × 138.24 (V)	mm
Pixel format	1280 (H) × 768 (V)	pixel
	(1 pixel = R+G+B dots)	
Aspect ratio	15 : 9	
Pixel pitch	0.180 (H) × 0.180 (V)	mm
Pixel configuration	R,G,B vertical stripe	
Display mode	Normally white	
Surface treatment	Glare and hard-coating 2H	

Parameter		Min.	Typ.	Max.	Unit
Unit outline dimensions [Note 1]	Width	298.7	242.4	299.3	mm
	Height	194.7	152.0	195.3	mm
	Depth	—	5.3	—	mm
Mass		—	202	217	g

[Note 1] excluding backlight cables.

Outline dimensions is shown in Fig.1

4. Input Terminals

4-1. TFT-LCD panel driving

CN1 (LVDS signals and +3.3V DC power supply)

Pin No.	Symbol	Function	Remark
1	Vcc	+3.3V power supply	
2	Vcc	+3.3V power supply	
3	GND		
4	GND		
5	RxIN0-	Receiver signal of LVDS CH0 (-)	[Note 1]
6	RxIN0+	Receiver signal of LVDS CH0 (+)	[Note 1]
7	RxIN1-	Receiver signal of LVDS CH1 (-)	[Note 1]
8	RxIN1+	Receiver signal of LVDS CH1 (+)	[Note 1]
9	RxIN2-	Receiver signal of LVDS CH2 (-)	[Note 1]
10	RxIN2+	Receiver signal of LVDS CH2 (+)	[Note 1]
11	CK IN-	Receiver signal of LVDS CLK (-)	[Note 1]
12	CK IN+	Receiver signal of LVDS CLK (+)	[Note 1]
13	GND		
14	GND		

[Note 1] Relation between RxIN_i(i=0,1,2) and actual data is shown in following section (4-2)(7-2).

[Note 2] The shielding case is connected with signal GND.

Using connector : DF19L-14P-1H (Hirose) or equivalent.

Corresponding connector : DF19G-14S-1C (Hirose) or equivalent.

4-2 LVDS interface block diagram

Using receiver : Single LVDS interface contained in a control IC

Corresponding Transmitter : THC63LVDM63A (THINE) or equivalent

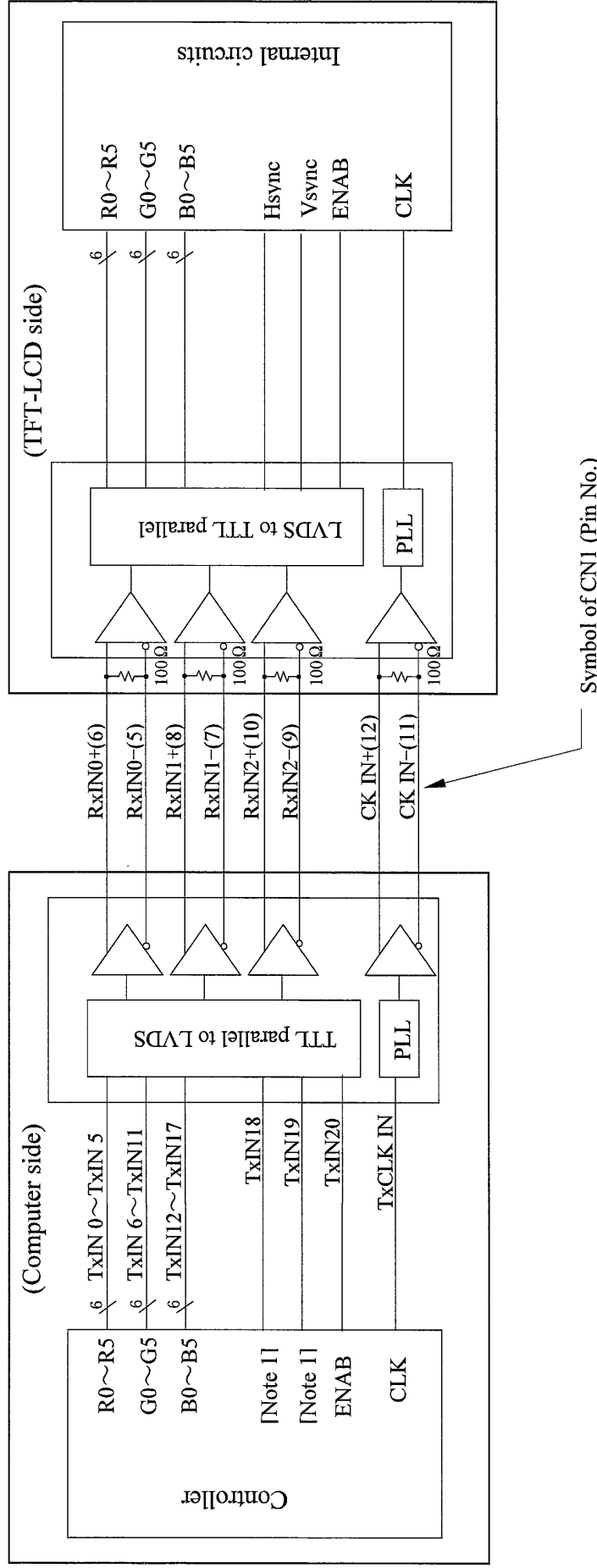

[Note 1] Do not use at high-impedance TxIN 18 - 19.

4.3. Backlight driving

CN2 Using connector:BHSR-02VS-1(JST)

Mating connector : SM02B-BHSS-1-TB(JST)

Connector No.	Pin No.	Symbol	Function
CN2	1	V_{High}	Power supply for lamp (High voltage side)
	2	V_{Low}	Power supply for lamp (Low voltage side)

5. Absolute Maximum Ratings

Parameter	Symbol	Condition	Ratings		Unit	Remark
			Min.	Max.		
Input voltage	V_I	$T_a=25^{\circ}C$	-0.3	$V_{cc}+0.3$	V	[Note 1]
+3.3V supply voltage	V_{cc}	$T_a=25^{\circ}C$	0	+4.0	V	
Storage temperature	T_{stg}	—	-25	+60	$^{\circ}C$	[Note 2]
Operating temperature (Ambient)	T_{opa}	—	0	+50	$^{\circ}C$	

[Note 1] LVDS signals

[Note 2] Humidity : 95%RH Max. at $T_a \leq +40^{\circ}C$.Maximum wet-bulb temperature at $+39^{\circ}C$ or less at $T_a > +40^{\circ}C$.

No condensation.

6. Electrical Characteristics

6-1.TFT-LCD panel driving

 $T_a = +25^{\circ}C$

Parameter	Symbol	Min.	Typ.	Max.	Unit	Remark	
Supply voltage	V_{cc}	+3.0	+3.3	+3.6	V	[Note 2]	
Current dissipation	I_{cc}	—	350	450	mA	[Note 3]	
Permissive input ripple voltage	V_{RP}	—	—	100	mV _{P.P}	$V_{cc} = +3.3V$	
Input voltage range	V_I	0	—	2.4	V	LVDS signals	
Differential input threshold voltage	High	V_{TH}	—	—	+100	mV	$V_{CM} = +1.2V$ [Note 1]
	Low	V_{TL}	-100	—	—	mV	
Input current (High)	I_{OH}	—	—	± 10	μA	$V_I = +2.4V$ $V_{cc} = +3.6V$	
Input current (Low)	I_{OL}	—	—	± 10	μA	$V_I = 0V$ $V_{cc} = 3.6V$	
Terminal resistor	R_T	—	100	—	Ω	Differential input	

[Note 1] V_{CM} : Common mode voltage of LVDS driver.

[Note 2]

On-off conditions for supply voltage

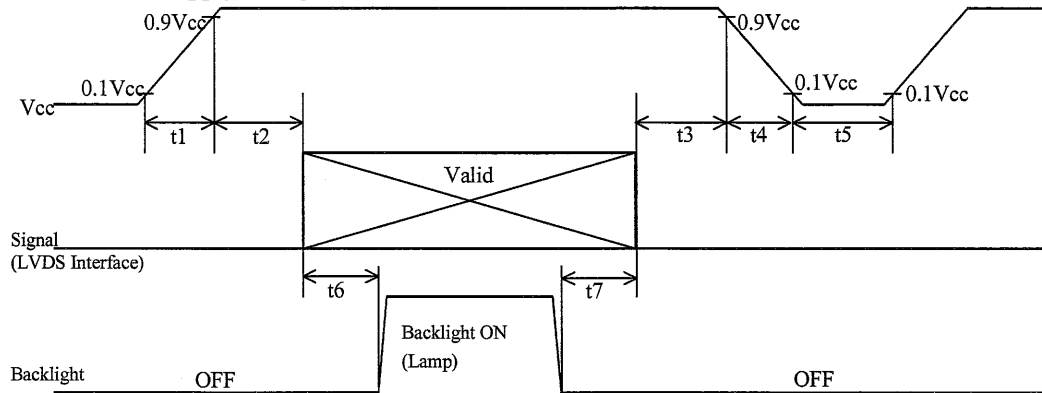

Symbol	Min.	Max.	Unit	Remark
t1	0	10	ms	
t2	0	1	s	
t3	0	1	s	
t4	0	400	ms	
t5	200	—	ms	
t6	180	—	ms	*1
t7	5	—	ms	*1

*1 : As for the power sequence for backlight, it is recommended to apply above mentioned input timing. If the backlight is lit on and off at a timing other than shown above, displaying image may get disturbed. This is due to variation of output signal from timing generator when LVDS signal is changed from on to off or vice versa, but has no harm to the module itself.

[Note] Do not keep the interface signal high-impedance or unusual signal when power is on.

Vcc-dip conditions

- 1) $2.5\text{ V} \leq V_{cc} < 3.0\text{ V}$

$t_d \leq 10\text{ ms}$

Under above condition, the display image should return to an appropriate figure after Vcc voltage recovers.

- 2) $V_{cc} < 2.5\text{ V}$

Vcc-dip conditions should also follow the On-off conditions for supply voltage

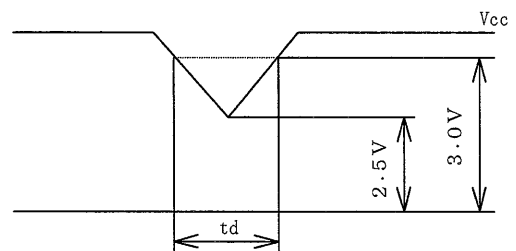

[Note 3] Typical current situation : 16-gray-bar pattern.

$V_{cc} = +3.3\text{ V}$

Maximum current situation : $V_{cc} = +3.0\text{ V}$

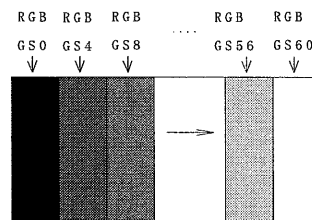

6-2. Backlight driving

The backlight system is edge-lighting type with single CCFT (Cold Cathode Fluorescent Tube).

The characteristics of one lamp are shown in the following table.

Parameter	Symbol	Min.	Typ.	Max.	Unit	Remark
Lamp current range	I_L	5.5	6.0	6.5	mArms	[Note 1]
Lamp voltage	V_L	—	530	—	Vrms	
Lamp power consumption	P_L	—	3.18	—	W	[Note 2]
Lamp frequency	F_L	37	49	60	kHz	[Note 3]
Kick-off voltage	V_S	—	—	1550	Vrms	$T_a=25^\circ\text{C}$
		—	—	1720	Vrms	$T_a=0^\circ\text{C}$
Lamp life time	L_L	10000	—	—	Hour	[Note 5]

[Note 1] The lamp current range, which can be turned on, is shown.

Lamp current measures by connecting the ammeter for high frequency to the V_{Low} side in the circuit of the following figure.

- Lamp frequency : 37~60kHz
- Temperature (Ambient) : 0~+50°C

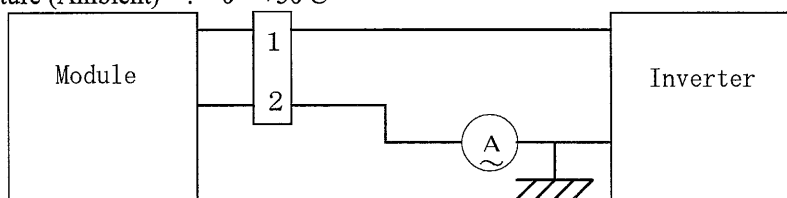

* 2pin is V_{Low}

In addition, please check lighting starting nature and lighting stability after mounting a module and an inverter on the occasion of use in a low current region.

[Note 2] Calculated value for reference ($I_L \times V_L$)

[Note 3] Lamp frequency may produce interference with horizontal synchronous frequency, and this may cause beat on the display. Therefore lamp frequency shall be detached as much as possible from the horizontal synchronous frequency and from the harmonics of horizontal synchronous to avoid interference.

[Note 4] It is defined at 22pF for the ballast capacitor of a DC/AC inverter.

The voltage above this value should be applied to the lamp for more than 1 second to start-up. Otherwise the lamp may not be turned on.

[Note 5] Above value is applicable when the long side of LCD module is placed horizontally.(Landscape position)

(Lamp lifetime may vary if LCD module is in portrait position due to the change of mercury density inside the lamp)

Lamp life time is defined as the time when either ① or ② occurs in the continuous operation under the condition of $T_a = 25^\circ\text{C}$ and $I_L = 6.0$ mArms.

① Brightness becomes 50 % of the original value under standard condition.

② Kick-off voltage at $T_a = 0^\circ\text{C}$ exceeds maximum value, 1720V rms.

[Note] The performance of the backlight, for example life time or brightness, is much influenced by the characteristics of the DC-AC inverter for the lamp.

When you design or order the inverter, please make sure that a poor lighting caused by the mismatch of the backlight and the inverter (miss-lighting, flicker, etc.) never occur.

When you confirm it, the module should be operated in the same condition as it is installed in your instrument.

[Note] Insulate the high voltage area in order to prevent direct contacts to the area. As countermeasures for excessive heat or exothermic fire, use protection elements such as fuses to cut the circuit.

Use burn-resistant (or noncombustible) material for board or resin.

7. Timing characteristics of input signals

7-1. Timing characteristics (This is specified at digital outputs of LVDS driver.)

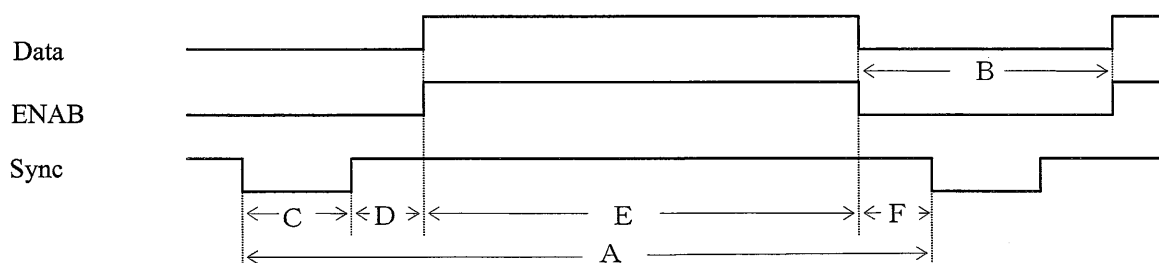

(Vertical)

Item (symbol)	Min.	Typ.	Max.	Unit	Remark
Vsync cycle (T_{VA})	—	16.667	—	ms	Negative
	800	802	900	line	
Blanking period (T_{VB})	32	34	132	line	
Sync pulse width (T_{VC})	2	6	—	line	
Back porch (T_{VD})	0	31	—	line	
Sync pulse width + Back porch ($T_{VC}+T_{VD}$)	—	31	—	line	
Active display area (T_{VE})	—	768	—	line	
Front porch (T_{VF})	1	3	—	line	

(Horizontal)

Item (symbol)	Min.	Typ.	Max.	Unit	Remark
Hsync cycle (T_{HA})	20.3	20.8	24.7	μs	Positive
	1652	1688	1856	clock	
Blanking period (T_{HB})	372	408	576	clock	
Sync pulse width (T_{HC})	2	112	—	clock	
Sync pulse width + Back porch ($T_{HC} + T_{HD}$)	4	360	$T_{HA}-1280$	clock	
Active display area (T_{HE})	1024	1024	1024	clock	

(Clock)

Item	Min.	Typ.	Max.	Unit	Remark
Frequency	70	81	85	MHz	【Note1】

Note) In case of lower frequency, the deterioration of display quality, flicker etc., may be occurred.

(Hsync-Vsync Phase difference)

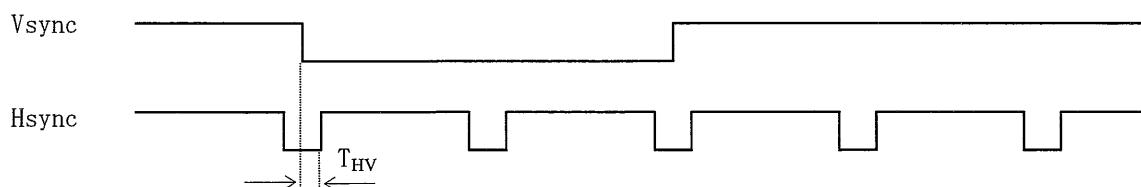

Item (symbol)	Min.	Typ.	Max.	Unit	Remark
Hsync-Vsync Phase difference (T_{HV})	1	—	$T_{HA}-T_{HC}$	clock	

(Hsync-ENAB Phase difference)

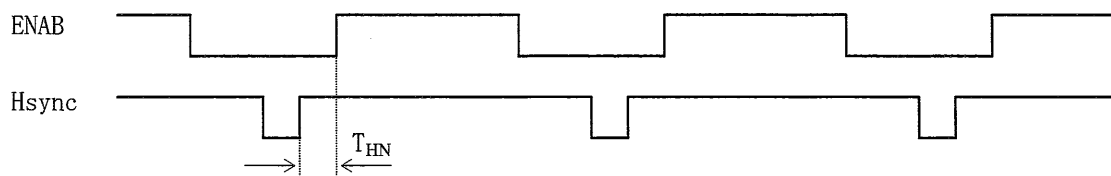

Item	Min.	Typ.	Max.	Unit	Remark
Hsync-ENAB Phase difference (T_{HN})	0	—	$T_{HA} - T_{HC}$	clock	

7-2 Display position

Item	Standards	Beginning	Ending	Unit	Remark
Horizontal	rising edge of ENAB	0	1280	clock	
	falling edge of Hsync	360	1640	clock	【Note1】
Vertical	falling edge of Vsync	31	799	clock	

【Note1】 ENAB signal must be fixed to low.

[Note]

(Horizontal display direction)

When ENAB is fixed low, 360 clock are counted from Hsync negative edge and data from after are available . If you need other timing, please use ENAB signal.

(Vertical display direction)

31 lines are counted from Vsync negative edge and data from next line are available.

(Note of ENAB signal)

ENAB could not be used for the purpose of the vertical display start timing.

Caution

Image will not be displayed on the right position otherwise.

7-3. Input data signals and display position on the screen

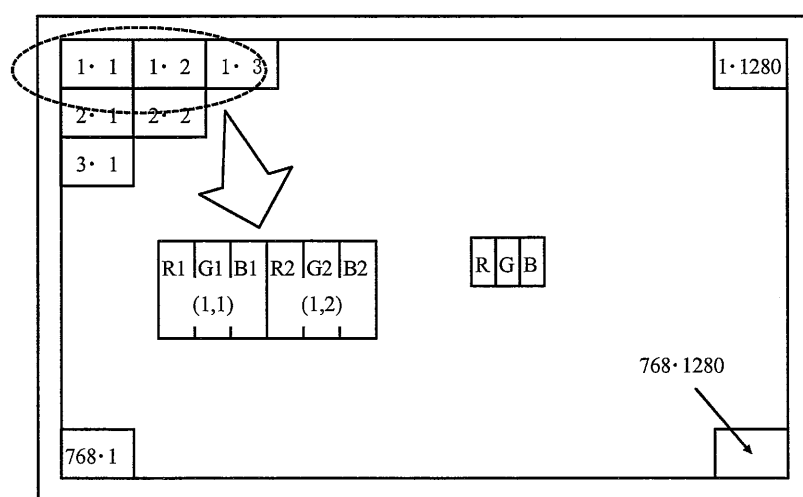

Display position of input data(V· H)

8. Input Signals, Basic Display Colors and Gray Scale of Each Color

Colors & Gray scale	Data signal																			
	Gray Scale	R0	R1	R2	R3	R4	R5	G0	G1	G2	G3	G4	G5	B0	B1	B2	B3	B4	B5	
Basic Color	Black	—	0	0	0	0	0	0	0	0	0	0	0	0	0	0	0	0	0	0
	Blue	—	0	0	0	0	0	0	0	0	0	0	0	0	1	1	1	1	1	1
	Green	—	0	0	0	0	0	0	1	1	1	1	1	1	0	0	0	0	0	0
	Cyan	—	0	0	0	0	0	0	1	1	1	1	1	1	1	1	1	1	1	1
	Red	—	1	1	1	1	1	1	0	0	0	0	0	0	0	0	0	0	0	0
	Magenta	—	1	1	1	1	1	1	0	0	0	0	0	0	1	1	1	1	1	1
	Yellow	—	1	1	1	1	1	1	1	1	1	1	1	1	0	0	0	0	0	0
	White	—	1	1	1	1	1	1	1	1	1	1	1	1	1	1	1	1	1	1
Gray Scale of Red	Black	GS0	0	0	0	0	0	0	0	0	0	0	0	0	0	0	0	0	0	0
	↑	GS1	1	0	0	0	0	0	0	0	0	0	0	0	0	0	0	0	0	0
	Darker	GS2	0	1	0	0	0	0	0	0	0	0	0	0	0	0	0	0	0	0
	↑	↓			↓					↓					↓					
	↓	↓			↓					↓					↓					
	Brighter	GS61	1	0	1	1	1	1	0	0	0	0	0	0	0	0	0	0	0	0
	↓	GS62	0	1	1	1	1	1	0	0	0	0	0	0	0	0	0	0	0	0
	Red	GS63	1	1	1	1	1	1	0	0	0	0	0	0	0	0	0	0	0	0
Gray Scale of Green	Black	GS0	0	0	0	0	0	0	0	0	0	0	0	0	0	0	0	0	0	0
	↑	GS1	0	0	0	0	0	0	1	0	0	0	0	0	0	0	0	0	0	0
	Darker	GS2	0	0	0	0	0	0	0	1	0	0	0	0	0	0	0	0	0	0
	↑	↓			↓					↓					↓					
	↓	↓			↓					↓					↓					
	Brighter	GS61	0	0	0	0	0	0	1	0	1	1	1	1	0	0	0	0	0	0
	↓	GS62	0	0	0	0	0	0	0	1	1	1	1	1	0	0	0	0	0	0
	Green	GS63	0	0	0	0	0	0	1	1	1	1	1	1	0	0	0	0	0	0
Gray Scale of Blue	Black	GS0	0	0	0	0	0	0	0	0	0	0	0	0	0	0	0	0	0	0
	↑	GS1	0	0	0	0	0	0	0	0	0	0	0	0	1	0	0	0	0	0
	Darker	GS2	0	0	0	0	0	0	0	0	0	0	0	0	0	1	0	0	0	0
	↑	↓			↓					↓					↓					
	↓	↓			↓					↓					↓					
	Brighter	GS61	0	0	0	0	0	0	0	0	0	0	0	0	1	0	1	1	1	1
	↓	GS62	0	0	0	0	0	0	0	0	0	0	0	0	0	1	1	1	1	1
	Blue	GS63	0	0	0	0	0	0	0	0	0	0	0	0	1	1	1	1	1	1

0 : Low level voltage, 1 : High level voltage

Each basic color can be displayed in 64 gray scales from 6 bit data signals. According to the combination of total 18 bit data signals, the 262,144-color display can be achieved on the screen.

9. Optical Characteristics

Ta=+25°C, Vcc=+3.3V

Parameter	Symbol	Condition	Min.	Typ.	Max.	Unit	Remark					
Viewing angle range	Horizontal	$\theta 21, \theta 22$	CR>5	70	80	—	Deg.	[Note 1,3,6]				
				Vertical	$\theta 11$	50	60		—	Deg.		
	$\theta 12$	60			70	—	Deg.					
	Horizontal	$\theta 21, \theta 22$		CR>10	60	70	—		Deg.	[Note 1,3,6]		
					Vertical	$\theta 11$	40		50		—	Deg.
						$\theta 12$	50		60		—	Deg.
Contrast ratio	CRn	$\theta = 0^\circ$	200	—	—		[Note 2,4,6]					
	CRo	Optimum viewing angle	200	350	—							
Response time	$\tau r + \tau d$	$\theta = 0^\circ$	—	30	40	ms	[Note 2,5,6]					
Chromaticity of white	x		0.292	0.322	0.352		[Note 2,6]					
	y		0.302	0.332	0.362							
Chromaticity of red	x		—	0.587	—							
	y		—	0.324	—							
Chromaticity of green	x		—	0.309	—							
	y		—	0.549	—							
Chromaticity of blue	x		—	0.150	—							
	y		—	0.132	—							
Luminance of white	Y _{LI}		200	240	—		[Note 2,6] I _L =6.0mA _{rms} F _L =49kHz					
White Uniformity	δ_w	—	—	1.45		[Note 2,7]						

The measurement shall be executed 30 minutes after lighting at rating. Condition : (I_L=6.0mA_{rms})

The optical characteristics shall be measured in a dark room or equivalent.

[Note 1] Measuring Viewing Angle Range

[Note 2] Other Measurements

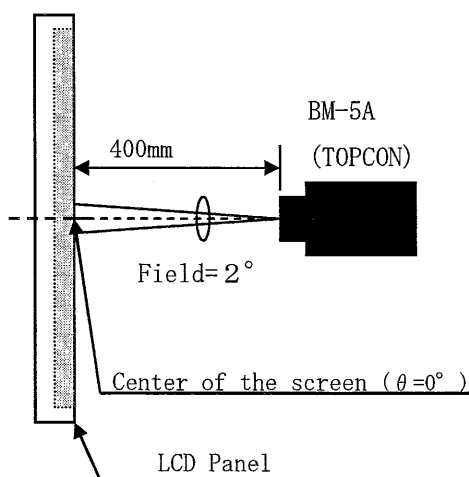
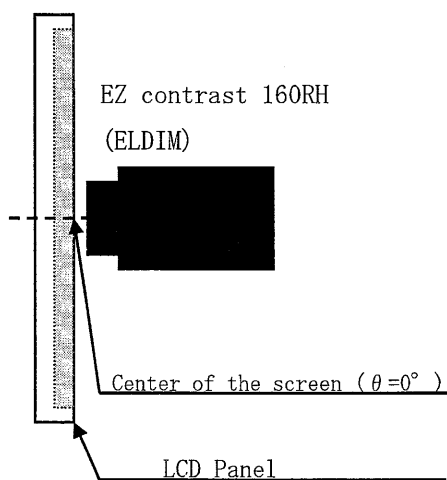

[Note 3] Definitions of viewing angle range:

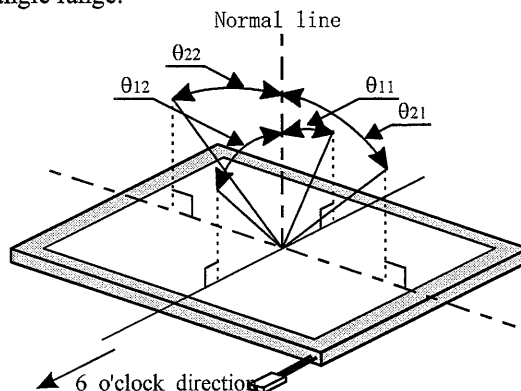

[Note 4] Definition of contrast ratio:

The contrast ratio is defined as the following.

$$\text{Contrast Ratio (CR)} = \frac{\text{Luminance (brightness) with all pixels white}}{\text{Luminance (brightness) with all pixels black}}$$

[Note 5] Definition of response time:

The response time is defined as the following figure and shall be measured by switching the input signal for "black" and "white" .

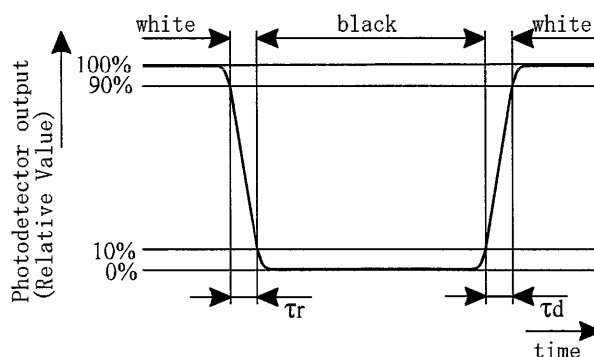

[Note 6] This shall be measured at center of the screen.

[Note 7] Definition of white uniformity:

White uniformity is defined as the following with five measurements (A~E).

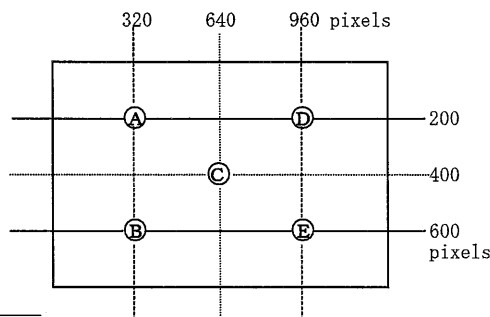

$$\delta_w = \frac{\text{Maximum Luminance of five points (brightness)}}{\text{Minimum Luminance of five points (brightness)}}$$

10. Handling Precautions

- a) Be sure to turn off the power supply when inserting or disconnecting the cable.
- b) Be sure to design the cabinet so that the module can be installed without any extra stress such as warp or twist.
- c) Since the front polarizer is easily damaged, pay attention not to scratch it.
- d) Wipe off water drop immediately. Long contact with water may cause discoloration or spots.
- e) When the panel surface is soiled, wipe it with absorbent cotton or other soft cloth.
- f) Since the panel is made of glass, it may break or crack if dropped or bumped on hard surface. Handle with care.
- g) Since CMOS LSI is used in this module, take care of static electricity and injure the human earth when handling. Observe all other precautionary requirements in handling components.
- h) This module has its circuitry PCBs on the rear side and should be handled carefully in order not to be stressed.
- i) Protect sheet is attached to the module surface to prevent it from being scratched. Peel the sheet off slowly just before the use with strict attention to electrostatic charges. Ionized air shall be blown over during the action. Blow off the 'dust' on the polarizer by using an ionized nitrogen gun, etc..
- j) Do not expose the LCD module to a direct sunlight, for a long period of time to protect the module from the ultra violet ray.
- k) Connect GND of mounting holes to stabilize against EMI and external noise.
- l) There are high voltage portions on the backlight and very dangerous. Careless touch may lead to electrical shock. When exchange lamps or service, turn off the power without fail.
- m) When handling LCD modules and assembling them into cabinets, please be noted that long-term storage in the environment of oxidization or deoxidization gas and the use of such materials as reagent, solvent, adhesive, resin, etc. which generate these gasses, may cause corrosion and discoloration of the LCD modules.
- n) Cold cathode fluorescent lamp in LCD panel contains a small amount of mercury, please follow local ordinances or regulations for disposal.
- o) Be careful not to pull the back light lead cable with an excessive strength, when connecting to the inverter or handling the cables.
- p) Adjusting volume have been set optimally before shipment, so do not change any adjusted value. If adjusted value is changed, the specification may not be satisfied.
- q) Disassembling the module can cause permanent damage and should be strictly avoided.
- r) Please be careful since image retention may occur when a fixed pattern is displayed for a long time.

11. Packing Form

Piling number of cartons	Max.6
Package quantity in one carton	20 pcs
Carton size	397(W)×313(D)×303(H) mm
Total mass of one carton filled with full modules	5.6kg

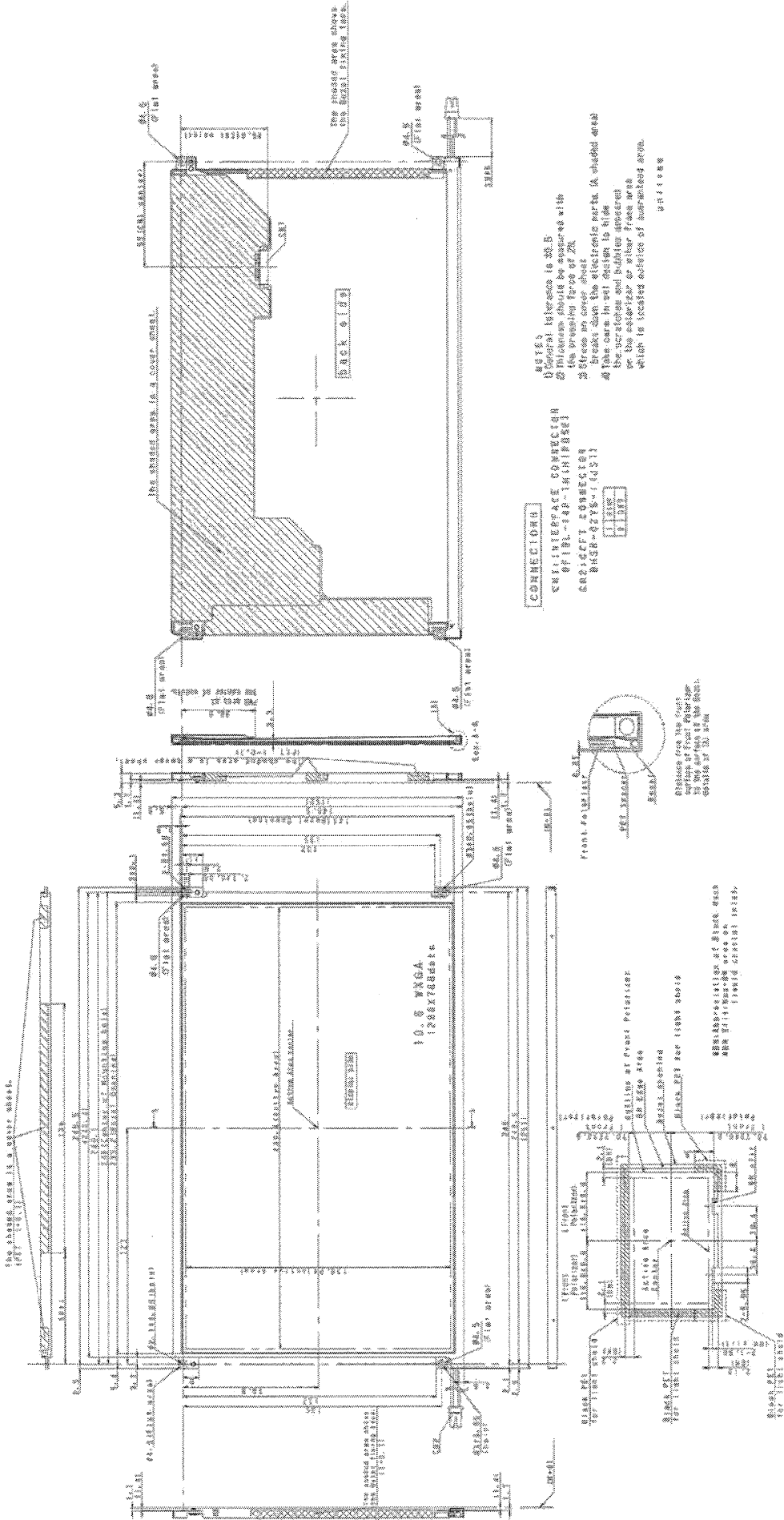

NOTES:
 1. General reference is to B.S.
 2. Dimensions should be measured with the pressure force of 2N.
 3. Break down the electric parts in shield shell into two parts: (1) front plate and (2) rear plate. The electric parts should be located at the rear of the shell which is located outside of mounting area.

CONNECTIONS

ENVIRONMENTAL CONNECTION OF FIBER OPTIC (IF REQUIRED)

ENVIRONMENTAL CONNECTION	1
FIBER OPTIC	1

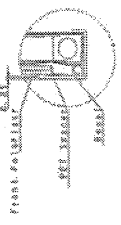

FRONT PLATE
 100-0101
 100-0102

Fig.1 Outline Dimensions