

SPEC No. LD-15919

ISSUE : Sep., 26, 03

PAGE : 22 pages

DEVICE SPECIFICATION FOR

TFT-LCD Module

MODEL No.

LQ0DZA1003

1. Application

This specification applies to the color 18.1 SXGA TFT-LCD module LQ0DZA1003.

The device listed in these specification sheets was designed and manufactured for use in OA equipment.

In case of using the device for applications such as control and safety equipment for transportation (aircraft, trains, automobiles, etc.), rescue and security equipment and various safety related equipment which require higher reliability and safety, take into consideration that appropriate measures such as fail-safe functions and redundant system design should be taken.

Do not use the device for equipment that requires an extreme level of reliability, such as aerospace applications, telecommunication equipment (trunk lines), nuclear power control equipment and medical or other equipment for life support.

2. Overview

This module is a color active matrix LCD module incorporating amorphous silicon TFT (Thin Film Transistor). It is composed of a color TFT-LCD panel, driver ICs, control circuit, power supply circuit and a back light unit. Graphics and texts can be displayed on a 1280 × 3 × 1024 dots panel with about 16 million colors (8 bit) by supplying 48 bit data signals (8bit × 2pixel × RGB) or 96 bit data signals (8bit × 4pixel × RGB), two display enable signals, two dot clock signals, +5V DC and +15V DC supply voltages for TFT-LCD panel driving and supply voltage for back light.

3. Mechanical Specifications

Parameter	Specifications	Unit
Display size	46 (Diagonal)	cm
	18.1 (Diagonal)	Inch
Active area	359.0 (H) × 287.2 (V)	Mm
Pixel format	1280 (H) × 1024 (V)	Pixel
	(1 pixel = R + G + B dots)	
Pixel pitch	0.2805 (H) × 0.2805 (V)	Mm
Pixel configuration	R,G,B vertical stripe	
Display mode	Normally Black	
Unit outline dimensions *1	414 (W) × 335 (H) × 24 (D)	Mm
Mass	3280 ± 80	g
Surface treatment	Anti-glare and hard-coating 2H	

*1.Note: excluding back light cables.

The thickness of module (D) doesn't contain the projection.

Outline dimensions are shown in Fig.1.

4. Input Terminals

4-1. TFT-LCD panel driving

CN1 (Interface signals and +5VDC / +15VDC power supply)

Using connector : SD-53493-1400 (Molex-Japan Co., Ltd.)

Mating connector : SD-52777-1400 (Molex-Japan Co., Ltd.)

Pin No.	Symbol	Function	Remark
1	GND	Gnd	
2	GND	Gnd	
3	GND	Gnd	
4	GND	Gnd	
5	RC7	RED odd data signal (MSB)	
6	RA7	RED odd data signal (MSB)	
7	RC6	RED odd data signal	
8	RA6	RED odd data signal	
9	RC5	RED odd data signal	
10	RA5	RED odd data signal	
11	RC4	RED odd data signal	
12	RA4	RED odd data signal	
13	Vcc	+5V power supply	
14	Vcc	+5V power supply	
15	RC3	RED odd data signal	
16	RA3	RED odd data signal	
17	RC2	RED odd data signal	
18	RA2	RED odd data signal	
19	RC1	RED odd data signal	
20	RA1	RED odd data signal	
21	RC0	RED odd data signal (LSB)	
22	RA0	RED odd data signal (LSB)	
23	GND	Gnd	
24	GND	Gnd	
25	GC7	GREEN odd data signal (MSB)	
26	GA7	GREEN odd data signal (MSB)	
27	GC6	GREEN odd data signal	
28	GA6	GREEN odd data signal	
29	GC5	GREEN odd data signal	
30	GA5	GREEN odd data signal	
31	GC4	GREEN odd data signal	
32	GA4	GREEN odd data signal	
33	Vcc	+5V power supply	
34	Vcc	+5V power supply	
35	GC3	GREEN odd data signal	
36	GA3	GREEN odd data signal	
37	GC2	GREEN odd data signal	
38	GA2	GREEN odd data signal	
39	GC1	GREEN odd data signal	
40	GA1	GREEN odd data signal	
41	GC0	GREEN odd data signal (LSB)	
42	GA0	GREEN odd data signal (LSB)	
43	GND	Gnd	
44	GND	Gnd	
45	BC7	BLUE odd data signal (MSB)	
46	BA7	BLUE odd data signal (MSB)	
47	BC6	BLUE odd data signal	
48	BA6	BLUE odd data signal	

49	BC5	BLUE odd data signal	
50	BA5	BLUE odd data signal	
51	BC4	BLUE odd data signal	
52	BA4	BLUE odd data signal	
53	Vcc	+5V power supply	
54	Vcc	+5V power supply	
55	BC3	BLUE odd data signal	
56	BA3	BLUE odd data signal	
57	BC2	BLUE odd data signal	
58	BA2	BLUE odd data signal	
59	BC1	BLUE odd data signal	
60	BA1	BLUE odd data signal	
61	BC0	BLUE odd data signal (LSB)	
62	BA0	BLUE odd data signal (LSB)	
63	GND	Gnd	
64	GND	Gnd	
65	DEB	Data enable signal (Signal to settle the display position)	
66	DEA	Data enable signal (Signal to settle the display position)	
67	Vcc	+5V power supply	
68	Vcc	+5V power supply	
69	CLKB	Sampling clock (for even data signal)	
70	CLKA	Sampling clock (for odd data signal)	
71	GND	Gnd	
72	GND	Gnd	
73	RD7	RED even data signal (MSB)	
74	RB7	RED even data signal (MSB)	
75	RD6	RED even data signal	
76	RB6	RED even data signal	
77	RD5	RED even data signal	
78	RB5	RED even data signal	
79	RD4	RED even data signal	
80	RB4	RED even data signal	
81	Vcc	+5V power supply	
82	Vcc	+5V power supply	
83	RD3	RED even data signal	
84	RB3	RED even data signal	
85	RD2	RED even data signal	
86	RB2	RED even data signal	
87	RD1	RED even data signal	
88	RB1	RED even data signal	
89	RD0	RED even data signal (LSB)	
90	RB0	RED even data signal (LSB)	
91	GND	Gnd	
92	GND	Gnd	
93	GD7	GREEN even data signal (MSB)	
94	GB7	GREEN even data signal (MSB)	
95	GD6	GREEN even data signal	
96	GB6	GREEN even data signal	
97	GD5	GREEN even data signal	
98	GB5	GREEN even data signal	
99	GD4	GREEN even data signal	
100	GB4	GREEN even data signal	
101	Vcc	+5V power supply	
102	Vcc	+5V power supply	

103	GD3	GREEN even data signal	
104	GB3	GREEN even data signal	
105	GD2	GREEN even data signal	
106	GB2	GREEN even data signal	
107	GD1	GREEN even data signal	
108	GB1	GREEN even data signal	
109	GD0	GREEN even data signal (LSB)	
110	GB0	GREEN even data signal (LSB)	
111	GND	Gnd	
112	GND	Gnd	
113	BD7	BLUE even data signal (MSB)	
114	BB7	BLUE even data signal (MSB)	
115	BD6	BLUE even data signal	
116	BB6	BLUE even data signal	
117	BD5	BLUE even data signal	
118	BB5	BLUE even data signal	
119	BD4	BLUE even data signal	
120	BB4	BLUE even data signal	
121	Vcc	+5V power supply	
122	Vcc	+5V power supply	
123	BD3	BLUE even data signal	
124	BB3	BLUE even data signal	
125	BD2	BLUE even data signal	
126	BB2	BLUE even data signal	
127	BD1	BLUE even data signal	
128	BB1	BLUE even data signal	
129	BD0	BLUE even data signal (LSB)	
130	BB0	BLUE even data signal (LSB)	
131	GND	Gnd	
132	GND	Gnd	
133	BLON	Back Light Status * 1	Output
134	MODE	H : 2pixel mode L : 4pixel mode	
135	GND	Gnd	
136	GND	Gnd	
137	Vdd	+15V power supply	
138	Vdd	+15V power supply	
139	Vdd	+15V power supply	
140	Vdd	+15V power supply	

* 1 When Vcc and Vdd are turned on, the output signal BLON goes to high typically 212 milliseconds later. The maximum output current is 1 milliamperere.

4-2. Back light driving

CN 2, 3

The module-side connector : XHP - 9 (JST)

The user-side connector : S9B - XH - A (JST)

Pin no.	Symbol	Function
1	V _{HIGH}	Power supply for lamp A (High voltage side)
2	NC	This is electrically opened.
3	NC	This is electrically opened.
4	V _{HIGH}	Power supply for lamp B (High voltage side)
5	NC	This is electrically opened.
6	NC	This is electrically opened.
7	V _{LOW}	Power supply for lamp B (Low voltage side)
8	NC	This is electrically opened.
9	V _{LOW}	Power supply for lamp A (Low voltage side)

The pair of pin 1 and pin 9 is for the same CCFT lamp. The pair of pin 4 and 7 is in the same way.

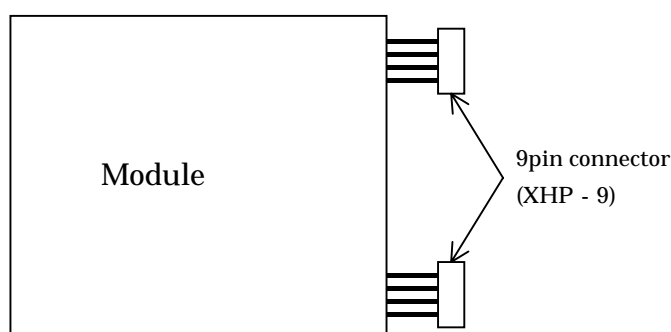

5. Absolute Maximum Ratings

Parameter	Symbol	Condition	Ratings	Unit	Remark
Input voltage	V _I	Ta=25	- 0.3 ~ +5.5	V	【Note1】
+5.0V supply voltage	V _{cc}	Ta=25	0 ~ + 6	V	
+15.0V supply voltage	V _{dd}	Ta=25	0 ~ + 17	V	
Storage temperature	T _{stg}	-	- 25 ~ + 60		【Note2】
Operating temperature (Ambient)	T _{opa}	-	0 ~ + 50		

【Note1】 CLKA, CLKB, RA0 ~ RA7, GA0 ~ GA7, BA0 ~ BA7, RB0 ~ RB7, GB0 ~ GB7, BB0 ~ BB7,

RC0 ~ RC7, GC0 ~ GC7, BC0 ~ BC7, RD0 ~ RD7, GD0 ~ GD7, BD0 ~ BD7, DEA, DEB, MODE

【Note2】 Humidity : 95%RH Max. (Ta 40)

Maximum wet-bulb temperature at 39 or less. (Ta>40)

No condensation.

6. Electrical Characteristics

6-1. TFT-LCD panel driving

Ta = 25

Parameter		Symbol	Min.	Typ.	Max.	Unit	Remark
Vcc	Supply voltage	Vcc	+4.75	+5.0	+5.25	V	【Note1】
	Current dissipation	Icc	-	130	500	mA	【Note2】
Vdd	Supply voltage	Vdd	+14.15	+15.0	+15.8	V	【Note1】
	Current dissipation	Idd	-	300	600	mA	【Note2】
Permissible input ripple voltage		V _{RFVcc}	-	-	100	mVp-p	Vcc=+5.0V
		V _{RFVdd}	-	-	300	mVp-p	
Input voltage (Low)		V _{IL}	0	-	+0.6	V	【Note3】
Input voltage (High)		V _{IH}	+2.7	-	+3.3	V	【Note3】
Input current (Low)		I _{IL}	-	-	10	μA	V _I =GND 【Note3】
Input current (High)		I _{IH}	-	-	10	μA	V _I =Vcc 【Note3】
Output voltage (Low)		V _{OL}	-	-	+0.4	V	I _{OL} =1mA
Output voltage (High)		V _{OH}	2.4	-	-	V	I _{OH} =-1mA

【Note1】

1) On sequence of two power supplies

(sequence free)

The case of (Va, Vb) = (Vcc, Vdd)

(Vmina, Vminb) = (4.75V, 14.0V)

The case of (Va, Vb) = (Vdd, Vcc)

(Vmina, Vminb) = (14.0V, 4.75V)

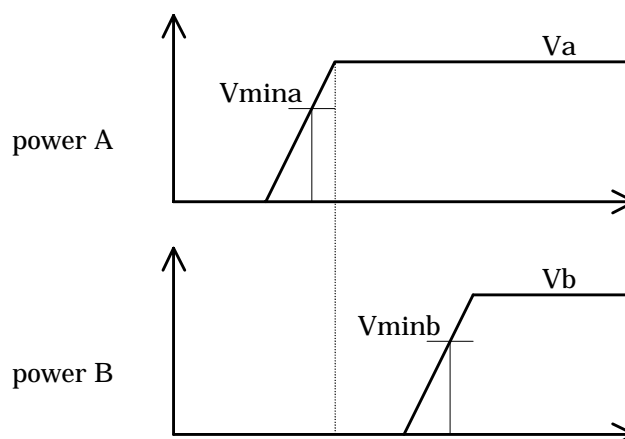

The LCD module turns on when (power A Vmina) and (power B Vminb).

2) Off sequence of two power supplies

The case of (Va, Vb) = (Vcc, Vdd)

(Vmina, Vminb) = (4.75V, 14.0V)

The case of (Va, Vb) = (Vdd, Vcc)

(Vmina, Vminb) = (14.0V, 4.75V)

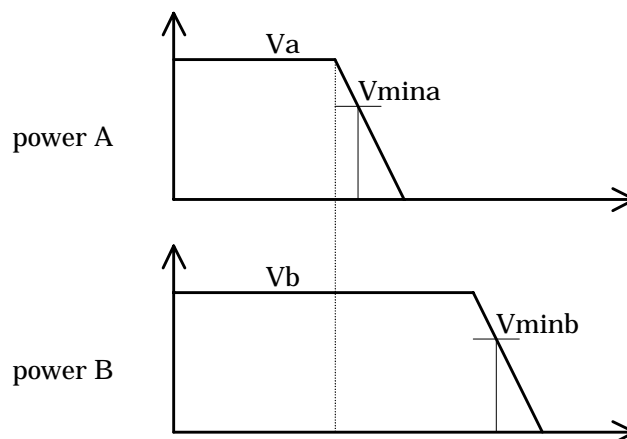

The LCD module shuts down when (power A Vmina) or (power B Vminb).

3) On-off sequences of Vcc and data

- 0 < t1 10ms
- 0 < t2 10ms
- 0 t3 10ms
- t4 1s

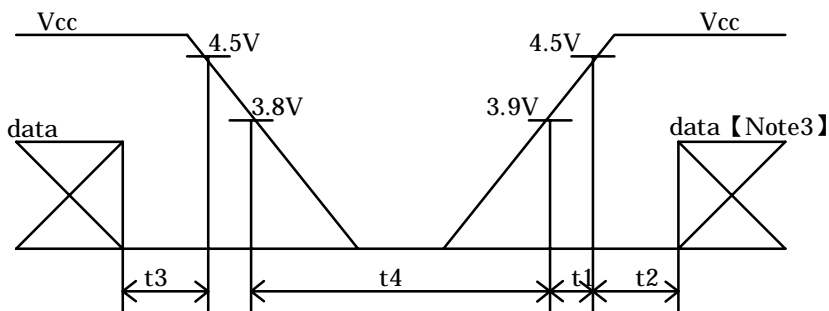

4) Dip conditions for supply voltage

The case of $V_p = V_{cc}$
 (V_{min}, V_{th}) = (4.75V, 3.8V)

- 1) 3.8V $V_{cc} < 4.75V$
 td 10ms

- 2) $V_{cc} < 3.8V$

This case is described below *1.

The case of $V_p = V_{dd}$

(V_{min}, V_{th}) = (14.0V, 4.2V)

- 1) 4.2V $V_{dd} < 14.0V$
 td 10ms

- 2) $V_{dd} < 4.2V$

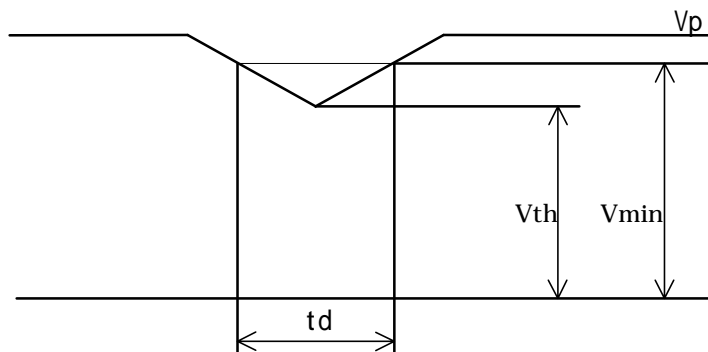

*1 The LCD module shuts down when ($V_{cc} < V_{th}$) or ($V_{dd} < V_{th}$).

If they (V_{cc}, V_{dd}) recover, the LCD module turns on following the 2 power sequence.

【Note2】 Typical current situation : 16-gray-bar pattern

$V_{cc} = +5.0V, V_{dd} = +15.0V$

Gray scale : GS(16N)

N=0 ~ 15

The explanation of each gray scale ,GS(16n), is described below section 8.

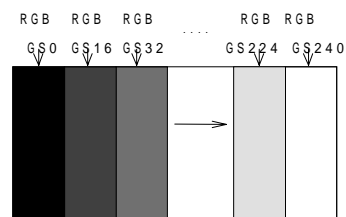

【Note3】 CLKA, CLKB, RA0 ~ RA7, GA0 ~ GA7, BA0 ~ BA7, RB0 ~ RB7, GB0 ~ GB7, BB0 ~ BB7,

RC0 ~ RC7, GC0 ~ GC7, BC0 ~ BC7, RD0 ~ RD7, GD0 ~ GD7, BD0 ~ BD7, DEA, DEB, MODE

6-2. Back light driving

The back light system is an edge-lighting type with four CCFTs (Cold Cathode Fluorescent Tube). The characteristics of the lamp are shown in the following table. The value mentioned below is at the case of one CCFT.

Parameter	Symbol	Min.	Typ.	Max.	Unit	Remark
Lamp current range	I_L	-	6.5	7.5	mArms	【Note1】
Lamp voltage	V_L	-	715	-	Vrms	$T_a=25$
Lamp power consumption	P_L	-	4.65	-	W	【Note2】
Lamp frequency	F_L	50	60	70	KHz	【Note3】
Kick-off voltage	V_s	-	-	1250	Vrms	$T_a=25$ 【Note4】
		-	-	1600	Vrms	$T_a=0$ 【Note4】
Lamp life time	T_L	50000	-	-	hour	【Note5】

【Note1】 A lamp can be light in the range of lamp current shown above.

Maximum rating for current is measured by high frequency current measurement equipment connected to V_{LOW} at circuit showed below. (Note : To keep enough kick-off voltage and necessary steady voltage for CCFT.)

Lamp frequency : 50 ~ 70kHz

Ambient temperature : 0 ~ 50

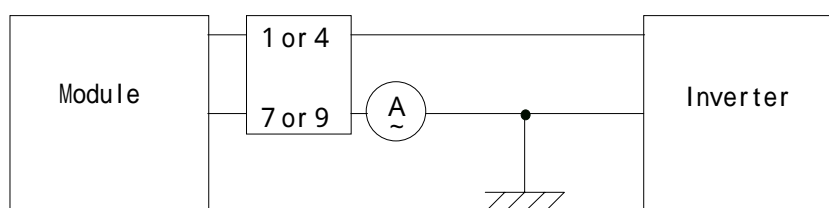

* 7 , 9 pin is V_{LOW}

【Note2】 Referential data per one CCFT by calculation ($I_L \times V_L$).

The data don't include loss at inverter.

【Note3】 Lamp frequency may produce interference with horizontal synchronous frequency, and this may cause beat on the display. Therefore lamp frequency shall be detached as much as possible from the horizontal synchronous frequency and from the harmonics of horizontal synchronous to avoid interference.

【Note4】 The voltage above this value should be applied to the lamp for more than 1 second to startup. Otherwise the lamp may not be turned on.

【Note5】 Lamp life time is defined as the time when either or occurs in the continuous operation under the condition of $T_a=25$ and $I_L=6.5$ mArms.

Brightness becomes 50% of the original value under standard condition.

Kick-off voltage at $T_a=0$ exceeds maximum value, 1600 Vrms.

《Note》 The performance of the back light, for example life time or brightness, is much influenced by the characteristics of the DC-AC inverter for the lamp. When you design or order the inverter, please make sure that a poor lighting caused by the mismatch of the back light and the inverter (miss-lighting, flicker, etc.) never occurs. When you confirm it, the module should be operated in the same condition as it is installed in your instrument.

7. Timing characteristics of input signals

7-1-1. 2pixel mode timing characteristics

Timing diagrams of input signal are shown in Fig.2.

Parameter		Symbol	Min.	Typ.	Max.	Unit	Remark
Clock	Frequency	1/Tc	34	55	60	MHz	【Note1】
	High time	Tch	4	-	-	ns	
	Low time	Tcl	4	-	-	ns	
	Skew	Tcsq	-1	0	1	clock	
Data	Setup time	Tds	3	-	-	ns	
	Hold time	Tdh	4	-	-	ns	
Data enable signal	Setup time	Tes	3	-	-	ns	
	Hold time	Teh	5	-	-	ns	
	Horizontal period	TH	668	848	928	clock	
			12.5	15	-	μs	
	Horizontal period (High)	THd	640	640	640	clock	
	Vertical period	TV	1026	1066	1080	line	【Note2】
Vertical period (High)	TVd	1024	1024	1024	line		

【Note1】 Two pixel-data are sampled at the same time.

【Note2】 In case of using the long vertical period, the deterioration of display quality, flicker etc. may occur.
There should be integral horizontal period per one vertical period.

7-1-2. 4pixel mode timing characteristics

Timing diagrams of input signal are shown in Fig.3.

Parameter		Symbol	Min.	Typ.	Max.	Unit	Remark
Clock	Frequency	1/Tc	17	22.5	30	MHz	【Note3】
	High time	Tch	4	-	-	ns	
	Low time	Tcl	4	-	-	ns	
	Skew	Tcsq	-1	0	1	clock	
Data	Setup time	Tds	3	-	-	ns	
	Hold time	Tdh	4	-	-	ns	
Data enable signal	Setup time	Tes	3	-	-	ns	
	Hold time	Teh	5	-	-	ns	
	Horizontal period	TH	334	424	464	clock	
			12.5	15	-	μs	
	Horizontal period (High)	THd	320	320	320	clock	
	Vertical period	TV	1026	1066	1080	line	【Note4】
Vertical period (High)	TVd	1024	1024	1024	line		

【Note3】 Four pixel-data are sampled at the same time.

【Note4】 In case of using the long vertical period, the deterioration of display quality, flicker etc. may occur.
There should be integral horizontal period per one vertical period.

7-2 Input Data Signals and Display Position on the screen

Graphics and texts can be displayed on a 1280 × 3 × 1024 dots panel with 16M colors by supplying 48 / 96 bit data signal (8bit/color [256 gray scale2] × 3 × 2 pixels / 4pixels).

7-2-1 2 pixel mode ; MODE="high"

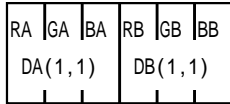

Two pixel-data are sampled at the same time.

* DA : RA0 ~ RA7, GA0 ~ GA7, BA0 ~ BA7

* DB : RB0 ~ RB7, GB0 ~ GB7, BB0 ~ BB7

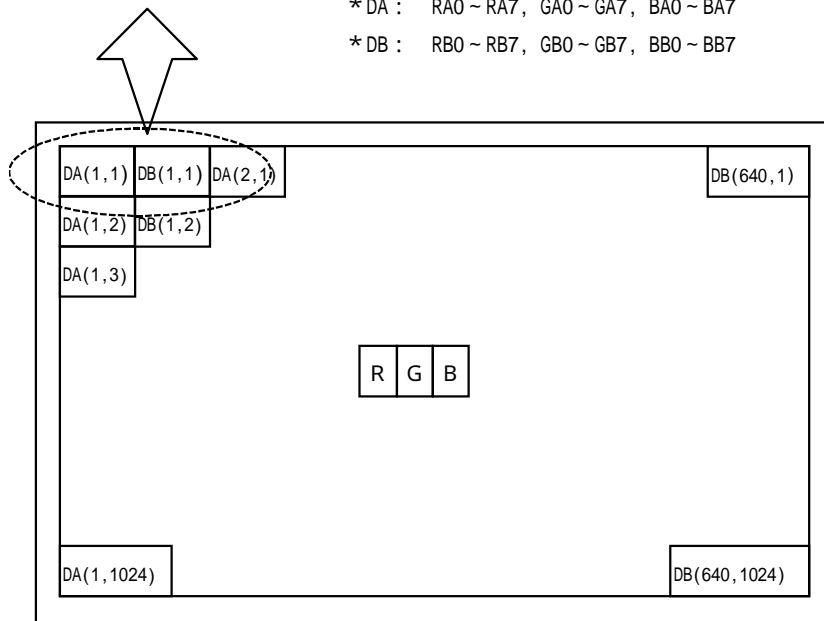

Display position of input data (H,V)

7-2-2 4 pixel mode ; MODE="low"

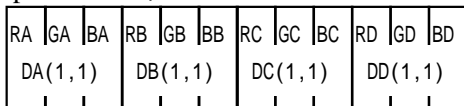

Four pixel-data are sampled at the same time.

* DA : RA0 ~ RA7, GA0 ~ GA7, BA0 ~ BA7

* DB : RB0 ~ RB7, GB0 ~ GB7, BB0 ~ BB7

* DC : RC0 ~ RC7, GC0 ~ GC7, BC0 ~ BC7

* DD : RD0 ~ RD7, GD0 ~ GD7, BD0 ~ BD7

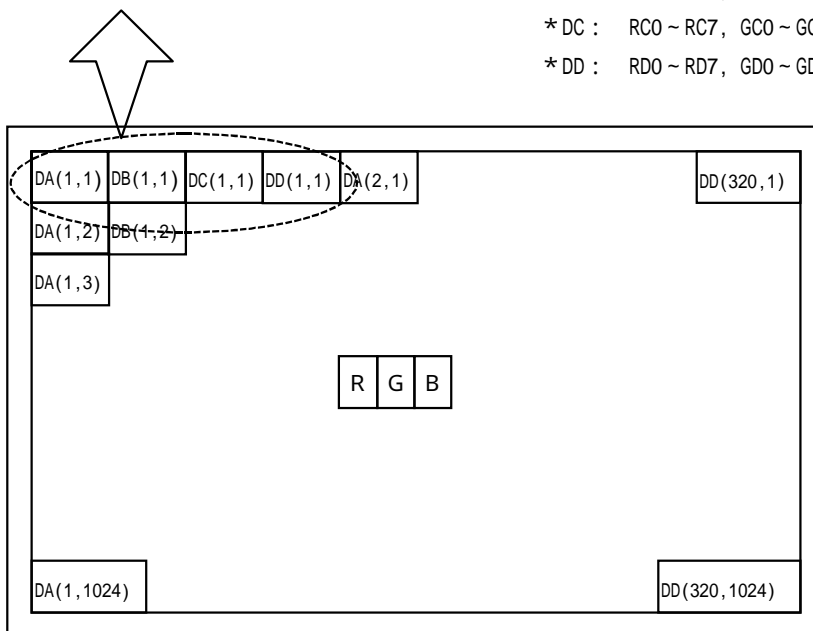

Display position of input data (H,V)

8. Input Signals, Basic Display Colors and Gray Scale of Each Color

	Colors & Gray scale	Data signal																											
		Gray	RA0 RA1 RA2 RA3 RA4 RA5 RA6 RA7	GA0 GA1 GA2 GA3 GA4 GA5 GA6 GA7	BA0 BA1 BA2 BA3 BA4 BA5 BA6 BA7																								
			RB0 RB1 RB2 RB3 RB4 RB5 RB6 RB7	GB0 GB1 GB2 GB3 GB4 GB5 GB6 GB7	BB0 BB1 BB2 BB3 BB4 BB5 BB6 BB7																								
			RC0 RC1 RC2 RC3 RC4 RC5 RC6 RC7	GC0 GC1 GC2 GC3 GC4 GC5 GC6 GC7	BC0 BC1 BC2 BC3 BC4 BC5 BC6 BC7																								
Scale	RD0 RD1 RD2 RD3 RD4 RD5 RD6 RD7	GD0 GD1 GD2 GD3 GD4 GD5 GD6 GD7	BD0 BD1 BD2 BD3 BD4 BD5 BD6 BD7																										
Basic Color	Black	-	0 0 0 0 0 0 0 0	0 0 0 0 0 0 0 0	0 0 0 0 0 0 0 0																								
	Blue	-	0 0 0 0 0 0 0 0	0 0 0 0 0 0 0 0	1 1 1 1 1 1 1 1																								
	Green	-	0 0 0 0 0 0 0 0	1 1 1 1 1 1 1 1	0 0 0 0 0 0 0 0																								
	Cyan	-	0 0 0 0 0 0 0 0	1 1 1 1 1 1 1 1	1 1 1 1 1 1 1 1																								
	Red	-	1 1 1 1 1 1 1 1	0 0 0 0 0 0 0 0	0 0 0 0 0 0 0 0																								
	Magenta	-	1 1 1 1 1 1 1 1	0 0 0 0 0 0 0 0	1 1 1 1 1 1 1 1																								
	Yellow	-	1 1 1 1 1 1 1 1	1 1 1 1 1 1 1 1	0 0 0 0 0 0 0 0																								
	White	-	1 1 1 1 1 1 1 1	1 1 1 1 1 1 1 1	1 1 1 1 1 1 1 1																								
Gray Scale of Red	Black	GS0	0 0 0 0 0 0 0 0	0 0 0 0 0 0 0 0	0 0 0 0 0 0 0 0																								
	↑	GS1	1 0 0 0 0 0 0 0	0 0 0 0 0 0 0 0	0 0 0 0 0 0 0 0																								
	Darker	GS2	0 1 0 0 0 0 0 0	0 0 0 0 0 0 0 0	0 0 0 0 0 0 0 0																								
	↑	↓																											
	↓	↓																											
	Brighter	GS250	1 0 1 1 1 1 1 1	0 0 0 0 0 0 0 0	0 0 0 0 0 0 0 0																								
	↓	GS251	0 1 1 1 1 1 1 1	0 0 0 0 0 0 0 0	0 0 0 0 0 0 0 0																								
	Red	GS252	1 1 1 1 1 1 1 1	0 0 0 0 0 0 0 0	0 0 0 0 0 0 0 0																								
Gray Scale of Green	Black	GS0	0 0 0 0 0 0 0 0	0 0 0 0 0 0 0 0	0 0 0 0 0 0 0 0																								
	↑	GS1	0 0 0 0 0 0 0 0	1 0 0 0 0 0 0 0	0 0 0 0 0 0 0 0																								
	Darker	GS2	0 0 0 0 0 0 0 0	0 1 0 0 0 0 0 0	0 0 0 0 0 0 0 0																								
	↑	↓																											
	↓	↓																											
	Brighter	GS250	0 0 0 0 0 0 0 0	1 0 1 1 1 1 1 1	0 0 0 0 0 0 0 0																								
	↓	GS251	0 0 0 0 0 0 0 0	0 1 1 1 1 1 1 1	0 0 0 0 0 0 0 0																								
	Green	GS252	0 0 0 0 0 0 0 0	1 1 1 1 1 1 1 1	0 0 0 0 0 0 0 0																								
Gray Scale of Blue	Black	GS0	0 0 0 0 0 0 0 0	0 0 0 0 0 0 0 0	0 0 0 0 0 0 0 0																								
	↑	GS1	0 0 0 0 0 0 0 0	0 0 0 0 0 0 0 0	1 0 0 0 0 0 0 0																								
	Darker	GS2	0 0 0 0 0 0 0 0	0 0 0 0 0 0 0 0	0 1 0 0 0 0 0 0																								
	↑	↓																											
	↓	↓																											
	Brighter	GS250	0 0 0 0 0 0 0 0	0 0 0 0 0 0 0 0	1 0 1 1 1 1 1 1																								
	↓	GS251	0 0 0 0 0 0 0 0	0 0 0 0 0 0 0 0	0 1 1 1 1 1 1 1																								
	Blue	GS252	0 0 0 0 0 0 0 0	0 0 0 0 0 0 0 0	1 1 1 1 1 1 1 1																								

0 : Low level voltage, 1 : High level voltage.

Each basic color can be displayed in 256 gray scales from 8 bit data signals. According to the combination of total 24 bit data signals, the 16-million-color display can be achieved on the screen.

9. Optical Characteristics

Ta=25 , Vcc=+5V, Vdd=+15V

Parameter		Symbol	Condition	Min.	Typ.	Max.	Unit	Remark
Viewing Angle range	Vertical	11	CR 10	70	85	-	Deg.	【Note1,4】
		12		70	85	-	Deg.	
	Horizontal	21, 22		70	85	-	Deg.	
Contrast ratio		C R	=0 °	-	350	-		【Note2,4】
Response Time	Rise	r		-	5	-	m s	【Note3,4】
	Decay	d		-	20	-	m s	
Chromaticity of white		Wx		0.278	0.308	0.338	-	【Note4】
		Wy		0.290	0.320	0.350	-	
Chromaticity of red		Rx		0.577	0.607	0.637	-	
		Ry		0.309	0.339	0.369	-	
Chromaticity of green		Gx		0.257	0.287	0.317	-	
		Gy		0.567	0.597	0.627	-	
Chromaticity of blue		Bx		0.115	0.145	0.175	-	
		By		0.057	0.087	0.117	-	
Luminance of white		YL		150	200	-	cd/m ²	IL=6.5mA rms FL = 60KH z 【Note4】
White Uniformity		w		-	-	1.25	-	【Note5】

The measurement shall be executed 30 minutes after lighting at rating.

The optical characteristics shall be measured in a dark room or equivalent state with the method shown in Fig.4 below.

【Note1】 Definitions of viewing angle range:

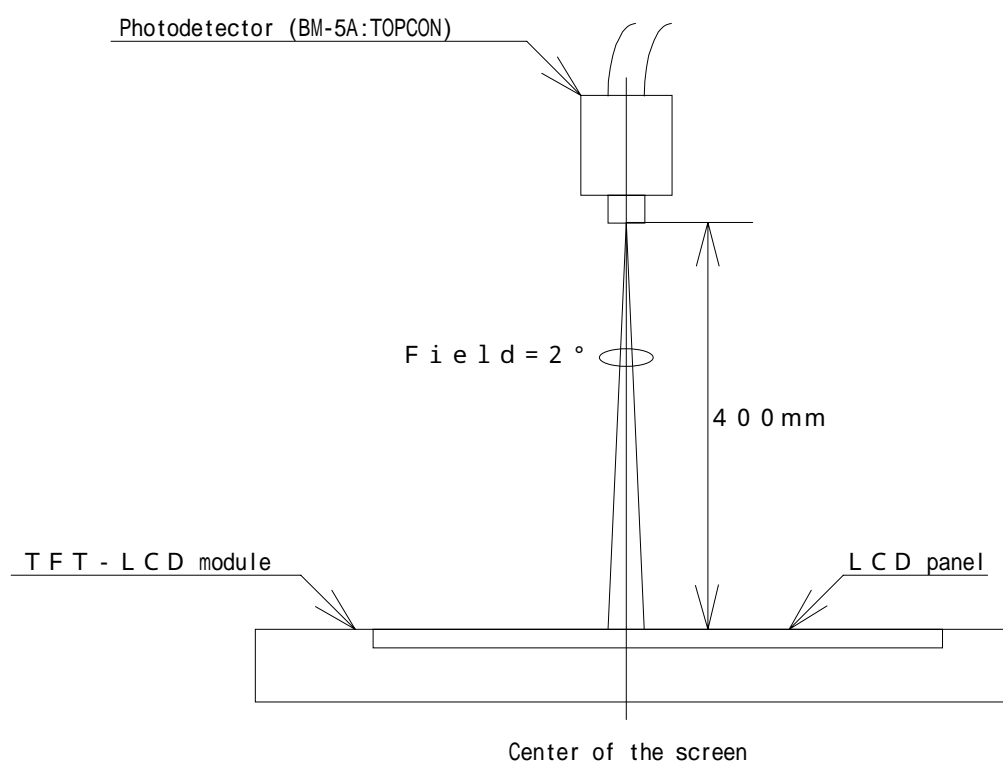
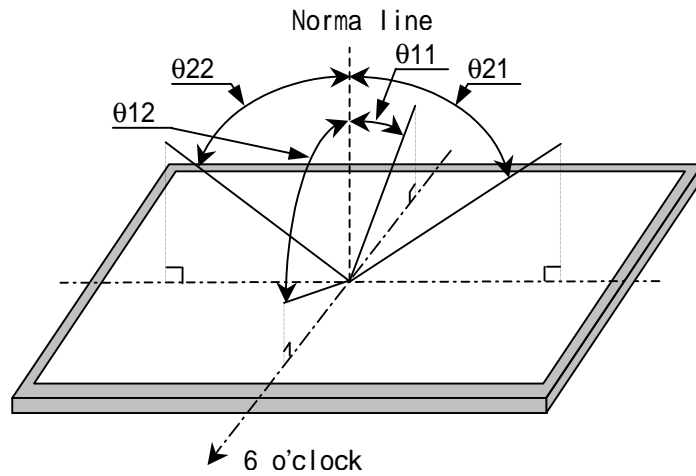

Fig.4 Optical characteristics measurement method



【Note2】 Definition of contrast ratio:

The contrast ratio is defined as the following.

$$\text{Contrast Ratio (CR)} = \frac{\text{Luminance (brightness) with all pixels white}}{\text{Luminance (brightness) with all pixels black}}$$

【Note3】 Definition of response time:

The response time is defined as the following figure and shall be measured by switching the input signal for "black" and "white".

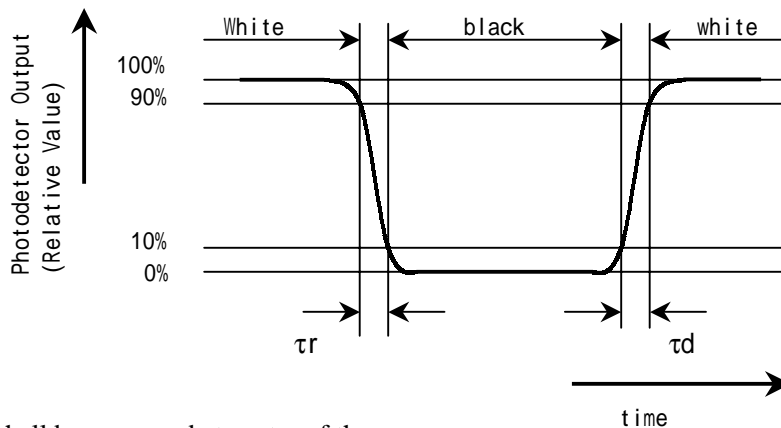

【Note4】 This shall be measured at center of the screen.

【Note5】 Definition of white uniformity:

White uniformity is defined as the following with five measurements (A ~ E).

$$w = \frac{\text{Maximum Luminance of five points (brightness)}}{\text{Minimum Luminance of five points (brightness)}}$$

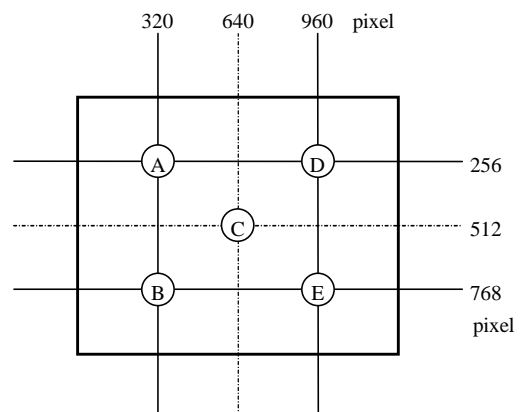

10. Handling Precautions

- a) Be sure to turn off the power supply when inserting or disconnecting the cable.
- b) Be sure to design the cabinet so that the module can be installed without any extra stress such as warp or twist.
- c) Since the front polarize is easily damaged, pay attention not to scratch it.
- d) Since long contact with water may cause discoloration or spots, wipe off water drop immediately.
- e) When the panel surface is soiled, wipe it with absorbent cotton or other soft cloth.
- f) Since the panel is made of glass, it may break or crack if dropped or bumped on hard surface. Handle with care.
- g) Since CMOS LSI is used in this module, take care of static electricity and take the human earth into consideration when handling.
- h) Make sure the four mounting holes of the module are grounded sufficiently. Take electro-magnetic interference (EMI) into consideration.
- i) The module has some printed circuit boards (PCBs) on the back side. Take care to keep them from any stress or pressure when handling or installing the module; otherwise some of electronic parts on the PCBs may be damaged.
- j) Observe all other precautionary requirements in handling components.
- k) When some pressure is added onto the module from rear side constantly, it causes display non-uniformity issue, functional defect, etc. So, please avoid such design.
- l) When giving a touch to the panel at power supply, it may cause some kinds of degradation. In that case, once turn off the power supply, and turn on after several seconds again, and that is disappear.

11. Packing form

- a) Piling number of cartons : maximum 12 cartons
- b) Packing quantity in one carton : 1 module
- c) Carton size : 585mm(W) × 506mm(H) × 120mm(D)
- d) Total mass of one carton filled with full modules : 5kg

12 . Reliability test items

No.	Test item	Conditions
1	High temperature storage test	Ta=60 240h
2	Low temperature storage test	Ta=-25 240h
3	High temperature & high humidity operation test	Ta=40 ; 95%RH 240h (No condensation)
4	High temperature operation test	Ta=50 240h (The panel temp. must be less than 60)
5	Low temperature operation test	Ta=0 240H
6	Vibration test (non- operating)	Frequency : 10 ~ 57Hz/Vibration width (one side) : 0.075mm : 58 ~ 500Hz/Gravity : 9.8m/s ² Sweep time : 11minutes Test period : 3 hours (1 hour for each direction of X,Y,Z)
7	Shock test (non- operating)	Max. gravity : 490m/s ² Pulse width : 11ms, sine wave Direction : ± X, ± Y, ± Z, once for each direction.

【Result Evaluation Criteria】

Under the display quality test conditions with normal operation state, these shall be no change which may affect practical display function.

13 . Others

1) Lot No. and indication Label:

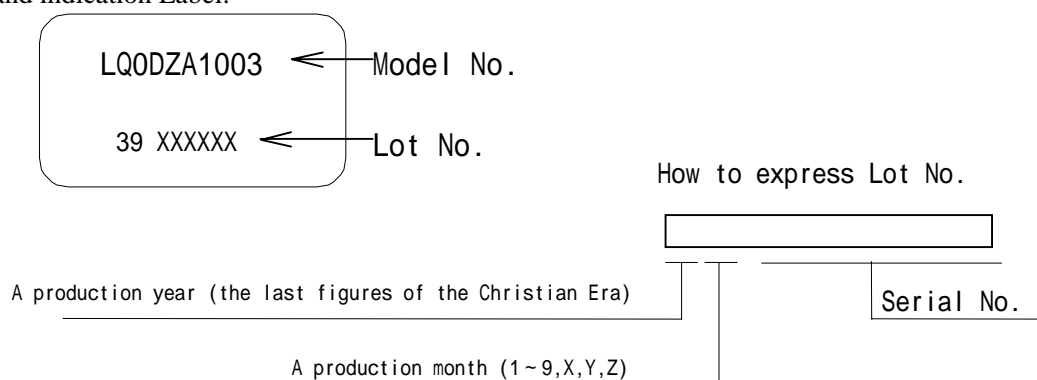

2) Adjusting volume have been set optimally before shipment, so do not change any adjusted value.

If adjusted value is changed, the specification may not be satisfied.

3) Disassembling the module can cause permanent damage and should be strictly avoided.

4) Please be careful since image retention may occur when a fixed pattern is displayed for a long time.

5) The chemical compound which causes the destruction of ozone layer is not being used.

6) Material information of LPG(Light Pipe Guide) are labeled on the back of the module.

MATERIAL INFORMATION
>PLASTIC LIGHT GUIDE:PMMA<

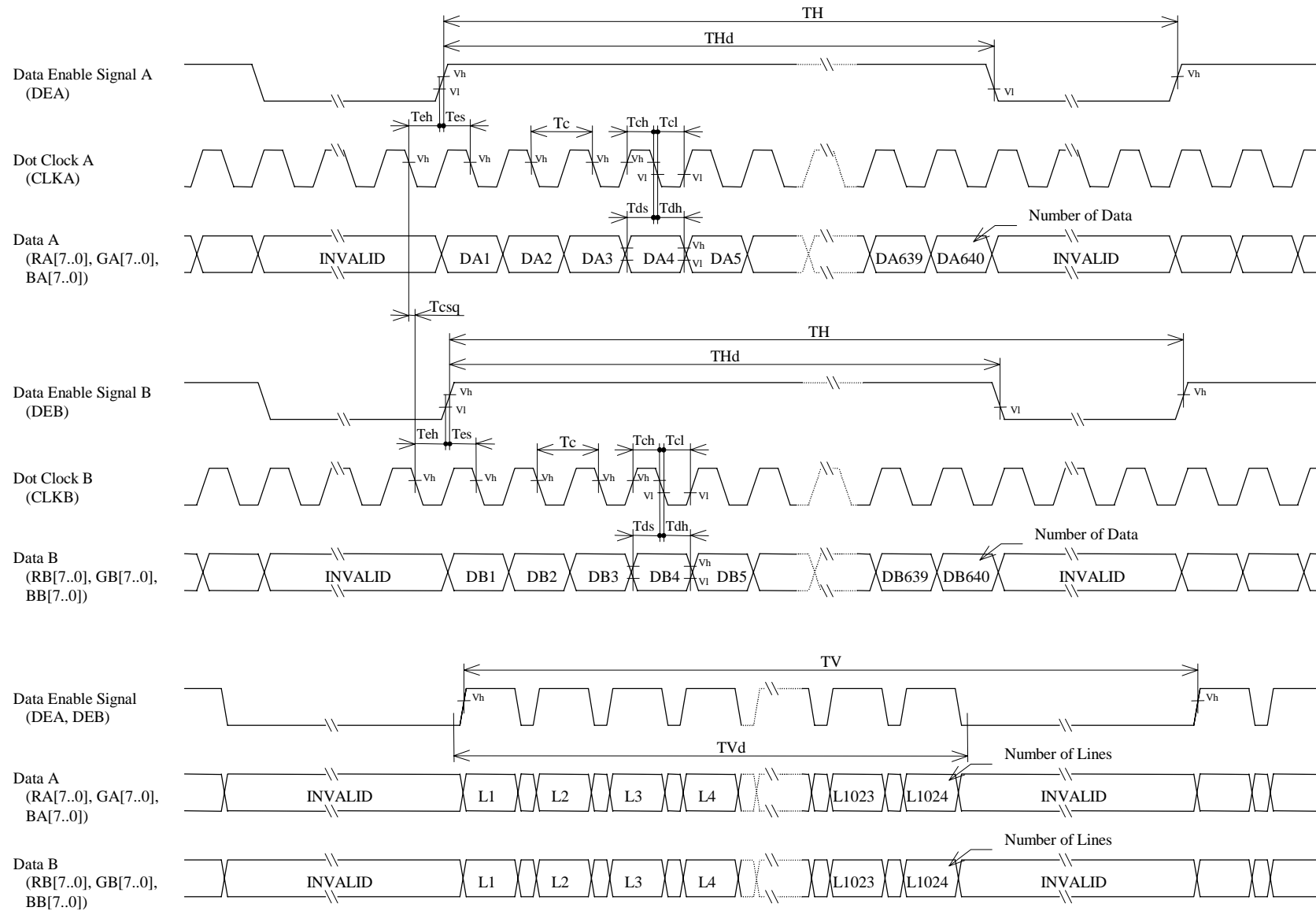

Fig. 2 2-pixel mode

Note : The following signal pins must be connected to the GND :
 RC[7..0], GC[7..0], BC[7..0], RD[7..0], GD[7..0], BD[7..0]

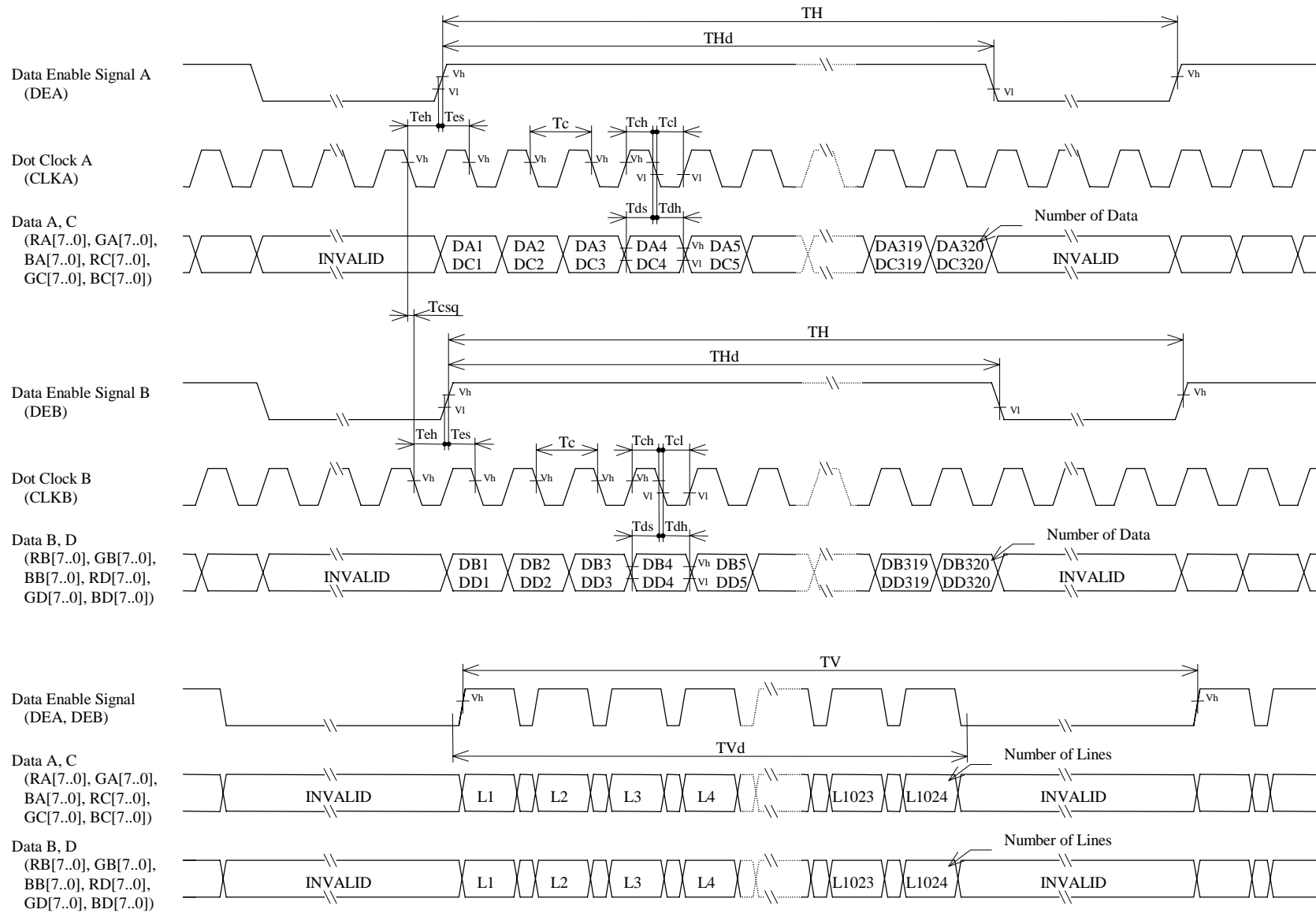

Fig. 3 4-pixel mode

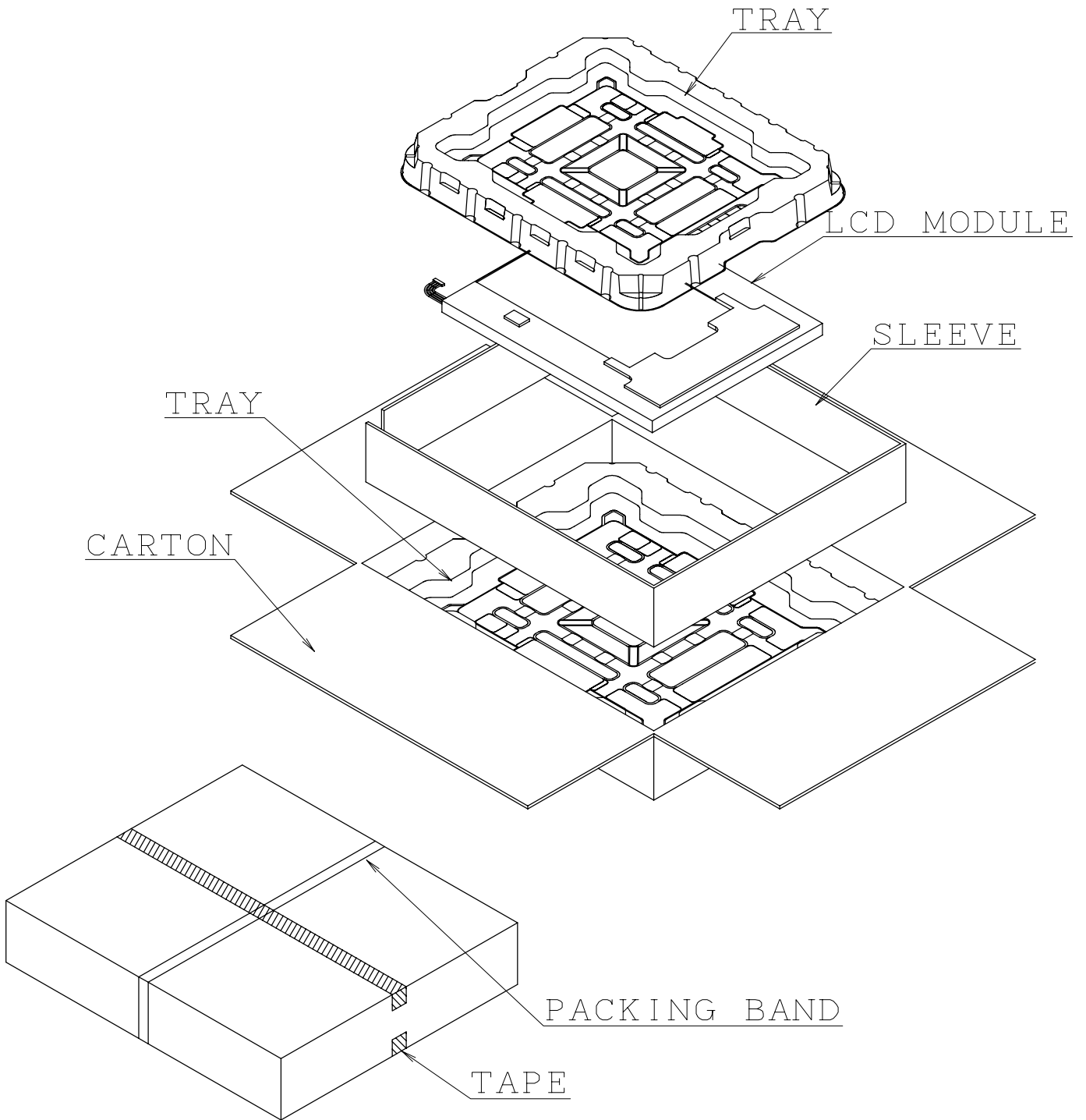
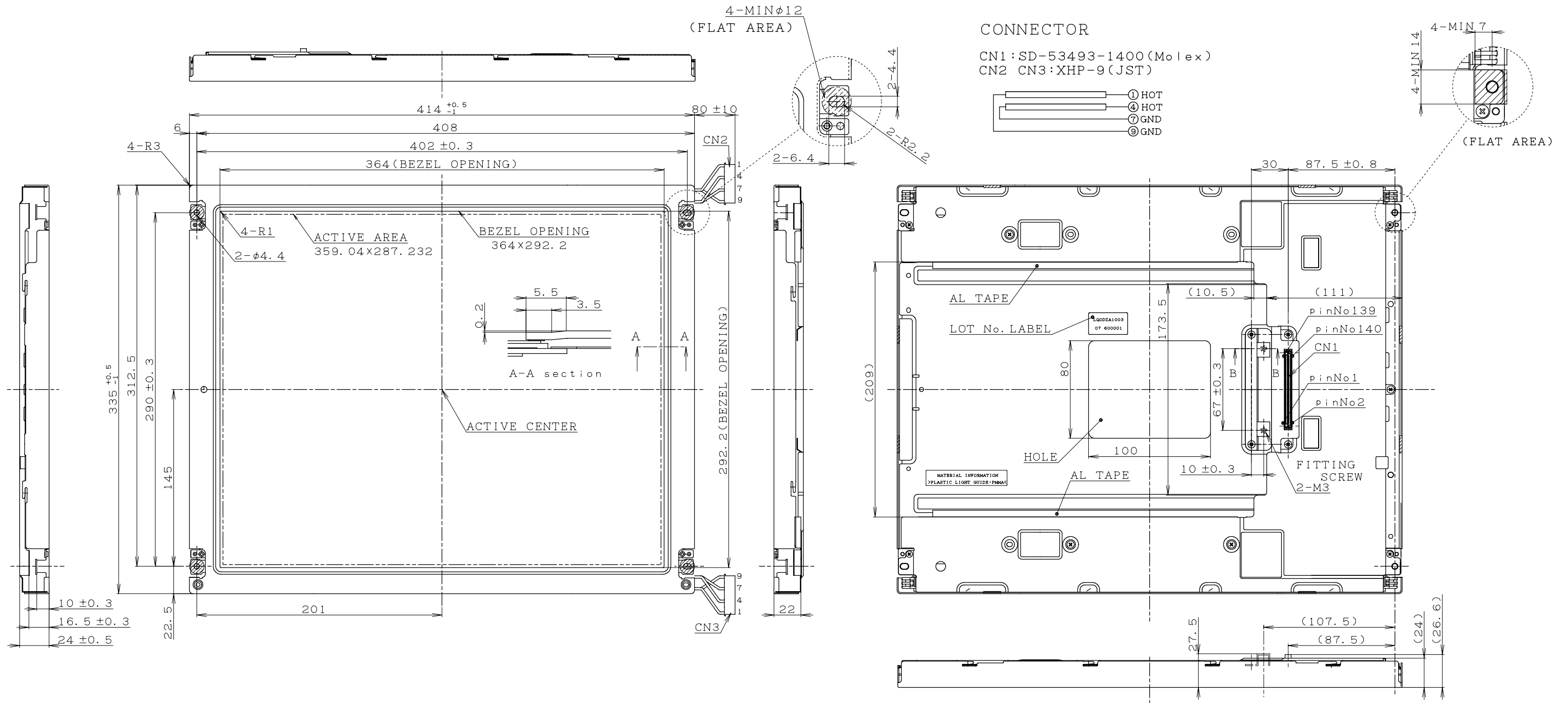
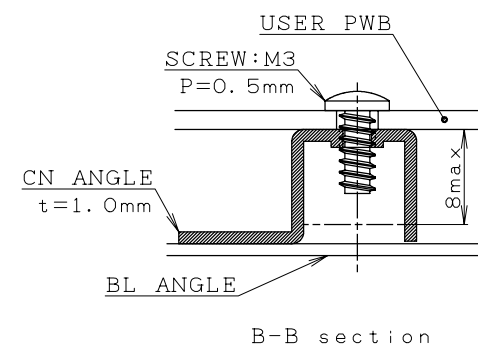

Fig. 5 PACKING FORM



NOTES

1. UNSPECIFIED TOLERANCE TO BE ± 0.8
2. WARP AND FLATING FOR BEZEL AND REARCASE ETC. ARE EXCLUDED FROM THICKNESS AND DIMENSION OF THE UNIT.



BEZEL/DISPLAY POSITION

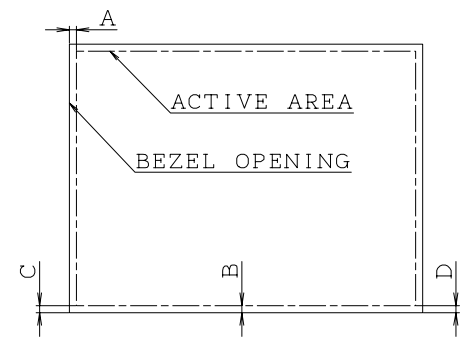

OUTLINE DIMENSIONS

- 1) TOLERANCE X-DIRECTION A: 2.5 ± 0.8
- 2) TOLERANCE Y-DIRECTION B: 2.5 ± 0.8
- 3) OBLIQUITY OF DISPLAY AREA |C-D| < 0.8