

PREPARED BY : DATE	<h1>SHARP</h1> MOBILE LIQUID CRYSTAL DISPLAY GROUP SHARP CORPORATION SPECIFICATION	SPEC No. LD-21408B
APPROVED BY : DATE		FILE No.
		ISSUE : May. 8. 2009
		PAGE : 17 pages
		APPLICABLE GROUP MOBILE LIQUID CRYSTAL DISPLAY GROUP

REVISION: Mar. 26. 2010

DEVICE SPECIFICATION FOR

TFT-LCD Module

MODEL No.

LQ104S1DG34

These parts have corresponded with the RoHS directive.

CUSTOMER'S APPROVAL

DATE _____

BY _____

PRESENTED
BY J. Kawanishi

J. Kawanishi
General manager
ENGINEERING DEPARTMENT I
MOBILE LIQUID CRYSTAL DISPLAY DIVISION II
MOBILE LIQUID CRYSTAL DISPLAY GROUP
SHARP CORPORATION

1. Application

This specification applies to color TFT-LCD module, LQ104S1DG34

These specification sheets are the proprietary product of SHARP CORPORATION("SHARP) and include materials protected under copyright of SHARP. Do not reproduce or cause any third party to reproduce them in any form or by any means, electronic or mechanical, for any purpose, in whole or in part, without the express written permission of SHARP.

The device listed in these specification sheets was designed and manufactured for use in general electronic equipment.

In case of using the device for applications such as control and safety equipment for transportation (controls of aircraft, trains, automobiles, etc.), rescue and security equipment and various safety related equipment which require higher reliability and safety, take into consideration that appropriate measures such as fail-safe functions and redundant system design should be taken.

Do not use the device for equipment that requires an extreme level of reliability, such as aerospace applications, telecommunication equipment (trunk lines), nuclear power control equipment and medical or other equipment for life support.

SHARP assumes no responsibility for any damage resulting from the use of the device which does not comply with the instructions and the precautions specified in these these specification sheets.

Confirm "12. Handling Precautions " item when you use the device.

Contact and consult with a SHARP sales representative for any questions about this device.

2. Overview

This module is a color active matrix LCD module incorporating amorphous silicon TFT (Thin Film Transistor). It is composed of a color TFT-LCD panel, driver ICs, control circuit and power supply circuit and a White-LED backlight unit. Graphics and texts can be displayed on a 800 X 3 X 600 dots panel with 262,144 colors by supplying 18 bit data signal (6bit/color), two timing signals and supplying +3.3V DC supply voltage for TFT-LCD panel driving and supply voltage for backlight.

The optimum viewing angle is 6 o'clock direction.

The viewing angle where gray scale doesn't reverse easily is 12 o'clock direction.

LED Backlight-driving DC/DC converter is not built in this module.

3. Outline specification.

Parameter	Specifications	Unit
Display size	26 (10.4") Diagonal	cm
Active area	211.2(H)×158.4(V)	mm
Pixel format	800(H)×600(V)	pixel
	(1 pixel=R+G+B dots)	-
Pixel pitch	0.264(H)×0.264(V)	mm
Pixel configuration	R,G,B vertical stripe	-
Display mode	Normally white	-
Unit outline dimensions *1	243.0(W)×183.8(H)×Max.(9.5) (D)	mm
Mass	500(MAX)	g
Surface treatment	Anti-glare and hard-coating 3H	-

*1: excluding backlight cables.

Outline dimensions is shown in Fig.1

4. Input Terminals

4-1. TFT-LCD panel driving

CN1 Employed connector: 9686S-40B-GF (IRISO) Terminal :Au plating 【Note 1】

Pin No.	Symbol	Function	Remark
1	Test1	TEST1(Please be sure to connect 1pin with ground)	—
2	GND	Ground	—
3	CK	Clock signal for sampling each data signal	—
4	GND	Ground	—
5	Test2	TEST2(Please be sure to connect 5pin with ground)	—
6	Test3	TEST3 (Please be sure to open 6pin)	—
7	R0	RED data signal(LSB)	—
8	R1	RED data signal	—
9	R2	RED data signal	—
10	GND	Ground	—
11	R3	RED data signal	—
12	R4	RED data signal	—
13	R5	RED data signal(MSB)	—
14	GND	Ground	—
15	G0	GREEN data signal(LSB)	—
16	G1	GREEN data signal	—
17	G2	GREEN data signal	—
18	GND	Ground	—
19	G3	GREEN data signal	—
20	G4	GREEN data signal	—
21	G5	GREEN data signal(MSB)	—
22	GND	Ground	—
23	B0	BLUE data signal(LSB)	—
24	B1	BLUE data signal	—
25	B2	BLUE data signal	—
26	GND	Ground	—
27	B3	BLUE data signal	—
28	B4	BLUE data signal	—
29	B5	BLUE data signal(MSB)	—
30	GND	Ground	—
31	Test4	TEST4 (Please be sure to open 31pin)	—
32	GND	Ground	—
33	Test5	TEST5 (Please be sure to open 33pin)	—
34	GND	Ground	—
35	ENAB	Data enable signal	【Note 2】
36	NC	No Connect	—
37	Vcc	power supply (+3.3V)	—
38	Vcc	power supply (+3.3V)	—
39	NC	No Connect	—
40	Vcc	power supply (+3.3V)	—

【Note 1】 Refer to the one that the size of FFC/FPC was recommended it of input connector.

The terminal of FFC/FPC of input connector recommend gold or gold plating specification.
Because point of contact with its is gold plating specification.

【Note 2】 The horizontal and vertical display location is designated and controlled by rising timing of ENAB signal. However if ENAB signal is fixed to “Low”, display is not able to display correct image. ...See: 8-2

4-2. Backlight driving

CN2 : (FPC Terminal :Au plating)

Corresponding connector : 9664S-06A-GFN1 (IRISO) Terminal :Au plating

Pin no.	symbol	function
1	+ch1	Power supply for LED1 (High voltage side)
2	-ch1	Power supply for LED1 (Low voltage side)
3	+ch2	Power supply for LED2 (High voltage side)
4	-ch2	Power supply for LED2 (Low voltage side)
5	+ch3	Power supply for LED3 (High voltage side)
6	-ch3	Power supply for LED3 (Low voltage side)

5. Absolute Maximum Ratings

Parameter	Symbol	Condition	Ratings	Unit	Remark
Input voltage	V_I	Ta=25°C	-0.3 ~ Vcc+0.3	V	【Note1】
+5V supply voltage	Vcc	Ta=25°C	0 ~ + 4.0	V	
Storage temperature	Tstg	—	-25~75	°C	
Operating temperature (PanelSurface)	Tops	—	0~75	°C	【Note2】 , 【Note3】

【Note1】 CK,R0~R5,G0~G5,B0~B5,ENAB

【Note2】 Humidity : 95%RH Max. at Ta≤40°C.

Maximum wet-bulb temperature at 39°C or less at Ta>40°C. (No condensation.)

【Note3】 There is a possibility of causing deterioration in the irregularity and others of the screen and the display fineness when preserving or using it from 65 to 75°C.

6. TFT-LCDpanel driving

Ta=25°C

Parameter	Symbol	Min.	Typ.	Max.	Unit	Remark
Supply voltage	V _{CC}	+3.0	+3.3	+3.6	V	【Note1】
Current dissipation	I _{CC}	—	300	450	mA	V _{CC} =3.3V 【Note2】
Current dissipation (Black pattern)	I _B	—	300	400	mA	V _{CC} =3.3V
Permissive input ripple voltage	V _{RF}	—	—	100	mVp-p	
Input voltage (Low)	V _{IL}	—	—	0.9	V	【Note3】
Input voltage (High)	V _{IH}	2.1	—	—	V	
Input current (low)	I _{OL1}	—	—	1.0	μA	V _I =0V 【Note4】
	I _{OL2}	—	—	10	μA	V _I =0V 【Note5】
Input current (High)	I _{OH1}	—	—	1.0	μA	V _I =V _{CC} 【Note4】
	I _{OH2}	—	—	300	μA	V _I =V _{CC} 【Note5】

【Note1】On-off conditions for supply voltage

- 0 < T₁ ≤ 15ms
- 0 < T₂ ≤ 10ms
- 0 < T₃ ≤ 100ms
- 0 < T₄ ≤ 1s
- 200ms < T₅

V_{CC}-dip conditions

- 1) 2.5V ≤ V_{CC}
T_d ≤ 10ms
- 2) V_{CC} < 2.5V

V_{CC}-dip conditions should also follow the On-off conditions for supply voltage

【Note2】 Typical current situation : 16-gray-bar pattern.

V_{CC}=+3.3V

【Note3】 CK,R0~R5,G0~G5,B0~B5,ENAB

【Note4】 CK,R0~R5,G0~G5,B0~B5

【Note5】 ENAB

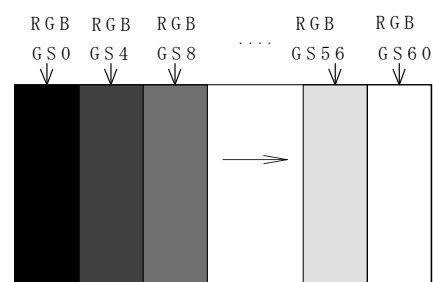
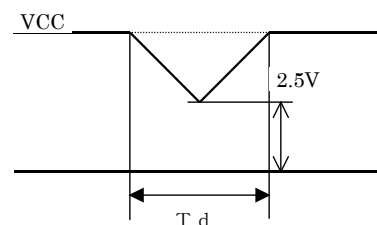
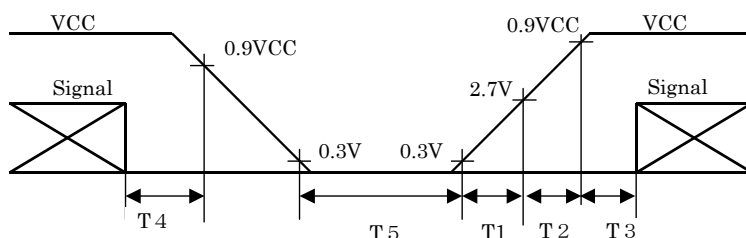

7. Backlight driving

The backlight system is an edge-lighting type with white-LED.

The characteristics of LED are shown in the following table..

(It is usually required to measure under the following condition. $T_a=25^{\circ}\text{C}\pm 2^{\circ}\text{C}$)

Parameter	Symbol	Min.	Typ.	Max.	Unit	Remark
LED voltage	V_F	—	31	36	V	Value for one channel
LED current range	I_F	—	18	20	mA	Value for one channel
Number of circuit channel		—	3	—		[Note 1]
Lamp power consumption	W_L	—	1.7	—	W	[Note 2]
LED Life time	L_L	—	25,000.	—	Hour	[Note 3]

[Note 1] The LED backlight is composed of 3 channels which (10)LED is connected in series.

[Note 2] Calculated value for reference ($I_F \times V_F \times 3$ channel)

[Note 3]①Lighting condition:

- The state of the LCD module installation: Landscape position and standing position
- Atmosphere temperature: 25°C
- Lighting current: 18mA (Constant current drive/Continuous turning on)

②Definition of Life time:

Brightness becomes 50% of the original value .(under condition ①)

8. Timing Characteristics of input signals

Timing diagrams of input signal are shown in Fig.2.

8-1. Timing characteristics

Parameter		Symbol	Min.	Typ.	Max.	Unit	Remark
Clock	Frequency	$1/T_c$	—	40.0	42.0	MHz	-
	High time	T_{ch}	6	-	-	ns	-
	Low time	T_{cl}	6	-	-	ns	-
	Duty ratio	T_h/T	40	50	60	%	-
Data	Setup time	T_{ds}	1	-	-	ns	-
	Hold time	T_{dh}	7	-	-	ns	-
Horizontal display period		TH_d	800	800	800	clock	-
Enable signal	Setup time	T_{es}	5	-	T_c-10	ns	-
	Pulse width	T_{ep}	2	800	$TH-10$	clock	-
Vertical display period		TV_d	600	600	600	clock	-

[Note] In case of lower frequency, the deterioration of display quality, flicker etc., may be occurred.

8-2. Horizontal /Vertical display position

Display start timing is settled in accordance with a rising timing of ENAB signal as shown in Fig.2.

8-3. Input Data Signals and Display Position on the screen

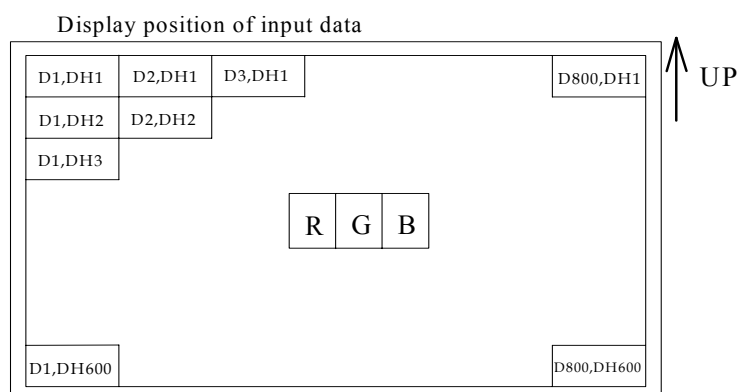

vertical display position

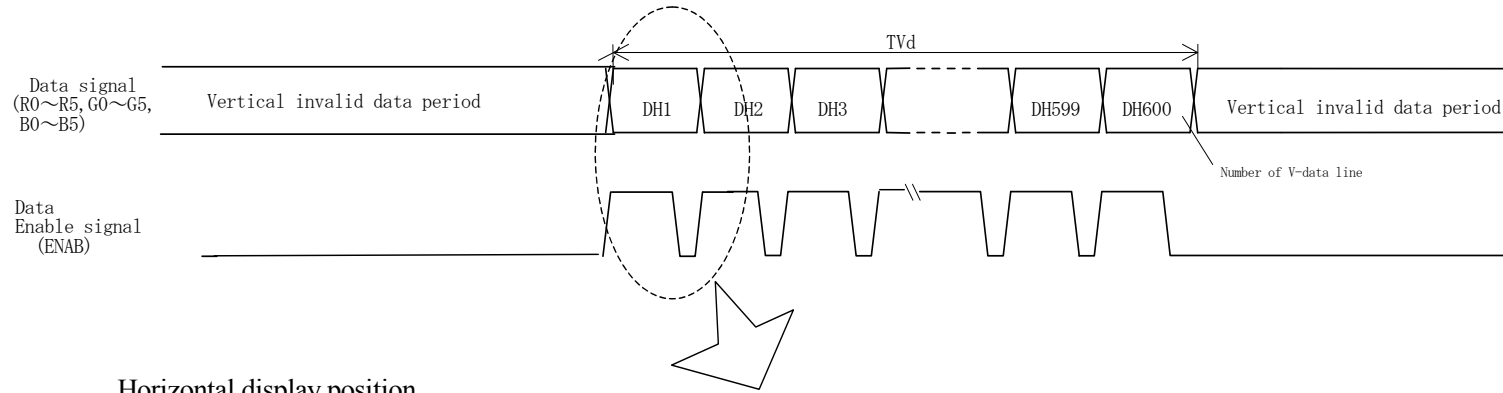

Horizontal display position

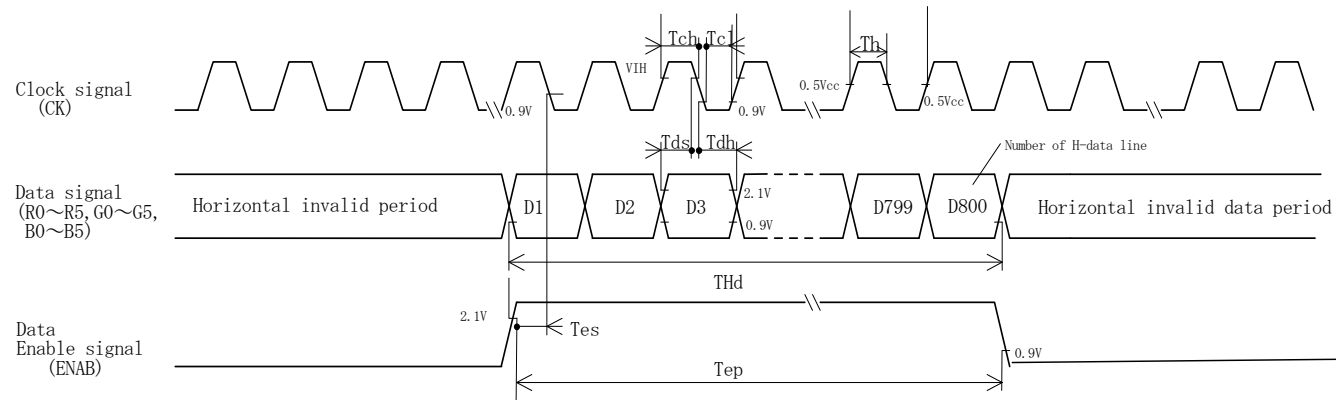

Fig. 2 Input signal waveforms

9. Input Signals, Basic Display Colors and Gray Scale of Each Color

	Colors &	Data signal																		
	Gray scale	Gray Scale	R0	R1	R2	R3	R4	R5	G0	G1	G2	G3	G4	G5	B0	B1	B2	B3	B4	B5
Basic Color	Black	—	0	0	0	0	0	0	0	0	0	0	0	0	0	0	0	0	0	0
	Blue	—	0	0	0	0	0	0	0	0	0	0	0	0	1	1	1	1	1	1
	Green	—	0	0	0	0	0	0	1	1	1	1	1	1	0	0	0	0	0	0
	Cyan	—	0	0	0	0	0	0	1	1	1	1	1	1	1	1	1	1	1	1
	Red	—	1	1	1	1	1	1	0	0	0	0	0	0	0	0	0	0	0	0
	Magenta	—	1	1	1	1	1	1	0	0	0	0	0	0	1	1	1	1	1	1
	Yellow	—	1	1	1	1	1	1	1	1	1	1	1	1	0	0	0	0	0	0
	White	—	1	1	1	1	1	1	1	1	1	1	1	1	1	1	1	1	1	1
Gray Scale of Red	Black	GS0	0	0	0	0	0	0	0	0	0	0	0	0	0	0	0	0	0	0
	↑	GS1	1	0	0	0	0	0	0	0	0	0	0	0	0	0	0	0	0	0
	Darker	GS2	0	1	0	0	0	0	0	0	0	0	0	0	0	0	0	0	0	0
	↑	↓			↓					↓					↓					
	↓	↓			↓					↓					↓					
	Brighter	GS61	1	0	1	1	1	1	0	0	0	0	0	0	0	0	0	0	0	0
	↓	GS62	0	1	1	1	1	1	0	0	0	0	0	0	0	0	0	0	0	0
	Red	GS63	1	1	1	1	1	1	0	0	0	0	0	0	0	0	0	0	0	0
Gray Scale of Green	Black	GS0	0	0	0	0	0	0	0	0	0	0	0	0	0	0	0	0	0	0
	↑	GS1	0	0	0	0	0	0	1	0	0	0	0	0	0	0	0	0	0	0
	Darker	GS2	0	0	0	0	0	0	0	1	0	0	0	0	0	0	0	0	0	0
	↑	↓			↓					↓					↓					
	↓	↓			↓					↓					↓					
	Brighter	GS61	0	0	0	0	0	0	1	0	1	1	1	1	0	0	0	0	0	0
	↓	GS62	0	0	0	0	0	0	0	1	1	1	1	1	0	0	0	0	0	0
	Green	GS63	0	0	0	0	0	0	1	1	1	1	1	1	0	0	0	0	0	0
Gray Scale of Blue	Black	GS0	0	0	0	0	0	0	0	0	0	0	0	0	0	0	0	0	0	0
	↑	GS1	0	0	0	0	0	0	0	0	0	0	0	0	1	0	0	0	0	0
	Darker	GS2	0	0	0	0	0	0	0	0	0	0	0	0	0	1	0	0	0	0
	↑	↓			↓					↓					↓					
	↓	↓			↓					↓					↓					
	Brighter	GS61	0	0	0	0	0	0	0	0	0	0	0	0	1	0	1	1	1	1
	↓	GS62	0	0	0	0	0	0	0	0	0	0	0	0	0	1	1	1	1	1
	Blue	GS63	0	0	0	0	0	0	0	0	0	0	0	0	1	1	1	1	1	1

0 :Low level voltage, 1 : High level voltage

Each basic color can be displayed in 64 gray scales from 6 bit data signals.

According to the combination of total 18 bit data signals, the 262,144-color display can be achieved on the screen.

10. Optical Characteristics

Ta=25°C, Vcc=+3.3V

Parameter		Symbol	Condition	Min.	Typ.	Max.	Unit	Remark
Viewing angle range	Horizontal	$\theta 21, \theta 22$	CR>10	60	70	-	Deg.	[Note1]
	Vertical	$\theta 11$		35	50	-	Deg.	[Note4]
		$\theta 12$		45	60	-	Deg.	[Note4]
Contrast ratio		CR	$\theta =0^\circ$	300	-	-		[Note2]
			Optimum viewing angle	-	500	-		[Note4]
Response time	Rise	τr	$\theta =0^\circ$	-	10	-	ms	[Note3]
	Decay	τd		-	25	-	ms	[Note4]
Chromaticity of white		x		0.253	0.313	0.373		[Note4]
		y		0.269	0.329	0.399		I _F = 18mA
Luminance of white		Y _L		175	250	-	cd/m ²	
White Uniformity		δW		-	-	1.45		[Note5]

[Note] The measurement shall be executed 30 minutes after lighting at rating.

The optical characteristics shall be measured in a dark room or equivalent state with the method shown in Fig.3 below. (I_F = 18mA)

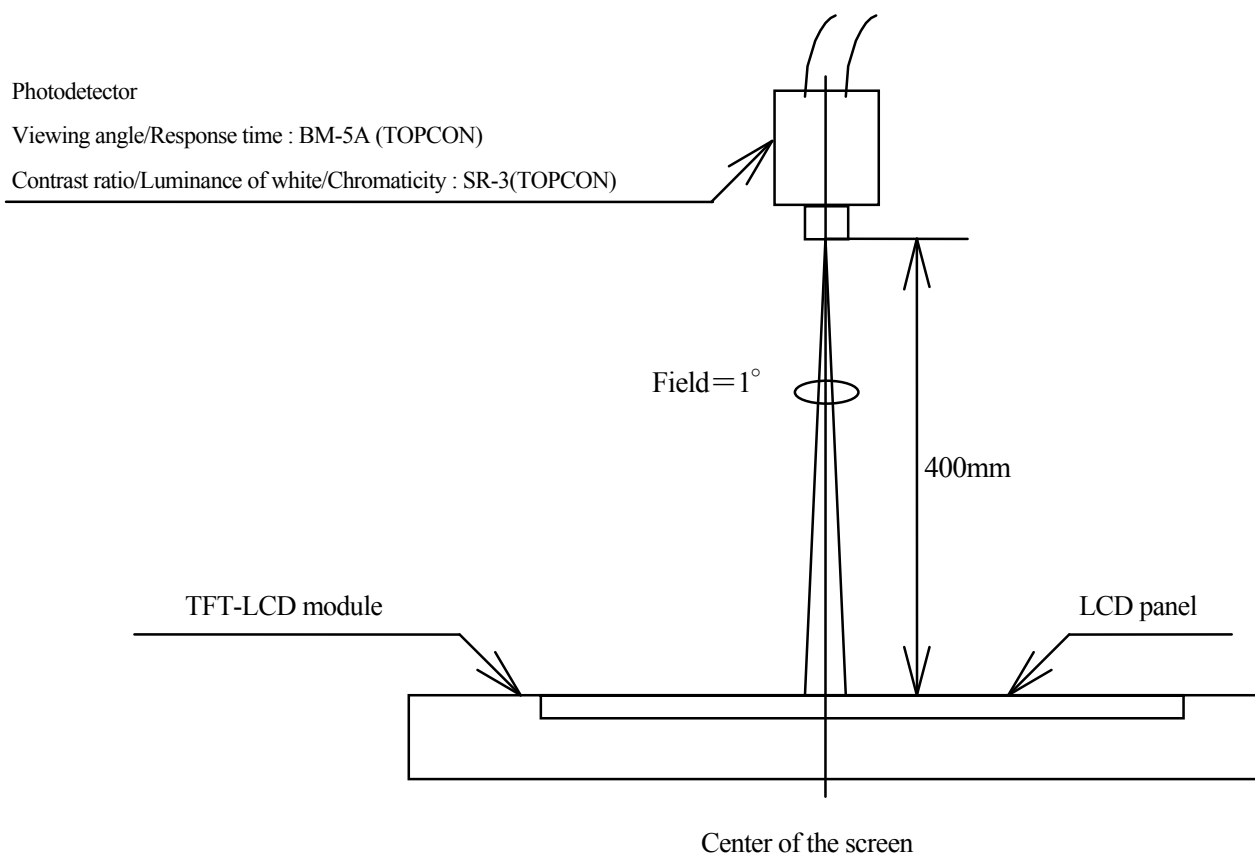
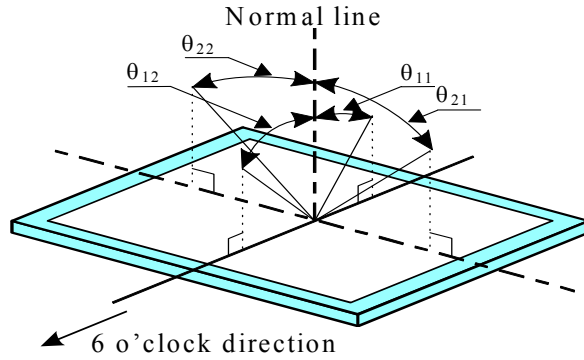

Fig.3 Optical characteristics measurement method

[Note1] Definitions of viewing angle range:



[Note2] Definition of contrast ratio:

The contrast ratio is defined as the following.

$$\text{Contrast Ratio (CR)} = \frac{\text{Luminance (brightness) with all pixels white}}{\text{Luminance (brightness) with all pixels black}}$$

[Note3] Definition of response time:

The response time is defined as the following figure and shall be measured by switching the input signal for "black" and "white" .

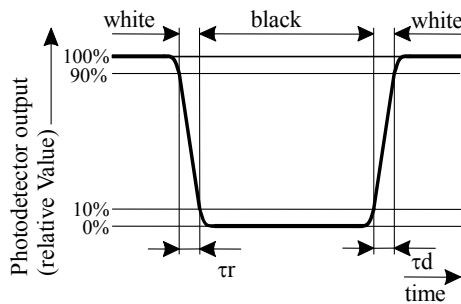

[Note4] This shall be measured at center of the screen.

[Note5] Definition of white uniformity:

White uniformity is defined as the following with five measurements (A~E).

$$\delta_w = \frac{\text{Maximum Luminance of five points (brightness)}}{\text{Minimum Luminance of five points (brightness)}}$$

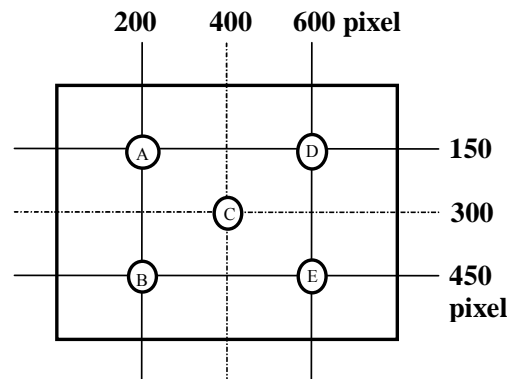

11. Display Quality

The display quality of the color TFT-LCD module shall be in compliance with the Incoming Inspection Standard.

12. Handling Precautions

- a) Be sure to turn off the power supply when inserting or disconnecting the cable.
- b) Be sure to design the cabinet so that the module can be installed without any extra stress such as warp or twist.
- c) Since the front polarizer is easily damaged, pay attention not to scratch it.
Blow away dust on the polarizer with antistatic N₂ blow. It is undesirable to wipe off because a polarizer is sensitive. It is recommended to peel off softly using the adhesive tape when soil or finger oil is stuck to the polarizer. When unavoidable, wipe off carefully with a cloth for wiping lenses.
- d) Wipe off water drop immediately. Long contact with water may cause discoloration or spots.
- e) When the panel surface is soiled, wipe it with absorbent cotton or other soft cloth.
- f) Since the panel is made of glass, it may break or crack if dropped or bumped on hard surface.
Handle with care.
- g) Since CMOS LSI is used in this module, take care of static electricity and injure the human earth when handling. Observe all other precautionary requirements in handling components.
- h) Since there is a circuit board in the module back, stress is not added at the time of a design assembly. Please make it like. If stress is added, there is a possibility that circuit parts may be damaged.
- i) Protection film is attached to the module surface to prevent it from being scratched .
Peel the film off slowly , just before the use, with strict attention to electrostatic charges.
Blow off 'dust' on the polarizer by using an ionized nitrogen.
- j) The polarizer surface on the panel is treated with Anti-Glare for low reflection. In case of attaching protective board over the LCD, be careful about the optical interface fringe etc. which degrades display quality.
- k) Do not expose the LCD panel to direct sunlight. Lightproof shade etc. should be attached when LCD panel is used under such environment.
- l) Connect GND to 4 place of mounting holes to stabilize against EMI and external noise.
- m) When handling LCD modules and assembling them into cabinets, please avoid that long-terms storage in the environment of oxidization or deoxidization gas and the use of such materials as reagent, solvent, adhesive, resin, etc. which generate these gasses, may cause corrosion and discoloration of the modules.
Do not use the LCD module under such environment.
- n) Be careful of a back light lead not to pull by force at the time of the wiring to a LED driver, or line processing.
- o) When install LCD modules in the cabinet, please tighten with “torque = $0.294 \pm 0.02\text{N} \cdot \text{m}$ ($3.0 \pm 0.2\text{kgf} \cdot \text{c m}$)”.
Be sure to confirm it in the same condition as it is installed in your instrument.
- p) Liquid crystal contained in the panel may leak if the LCD is broken. Rinse it as soon as possible if it gets inside your eye or mouth by mistake.
- q) Notice : Never dismantle the module , because it will cause failure.
Please do not peel off the Black tape pasted to the product. However, the panel protection film is excluded.
- r) Be careful when using it for long time with fixed pattern display as it may cause accidental image.
- s) Adjusting volume have been set optimally before shipment, so do not change any adjusted value.
If adjusted value is changed, the specification may not be satisfied.
- t) If a minute particle enters in the module and adheres to an optical material, it may cause display non-uniformity issue, etc. Therefore, fine-pitch filters have to be installed to cooling and inhalation hole if you intend to install a fan.
- u) The LED used for this product is very sensitive to the temperature. Luminance decreases rapidly when it is used for a long time under the environment of the high temperature. Please consult our company when it is used under the environment like the above mentioned.

13. Packing form

Product countries	JAPAN	CHINA
Piling number of cartons	6	
Package quantity in one carton	20	
Carton size	486(W) × 403(D) × 322(H)	
Total mass of one carton filled with full modules	12K g	
Packing form is shown	Fig.4	

14. Reliability test items

No.	Test item	Conditions	Remark
1	High temperature storage test	Ta=75°C 240h	
2	Low temperature storage test	Ta=- 25°C 240h	
3	High temperature & high humidity operation test	Ta=40°C ; 95%RH 240h (No condensation)	
4	High temperature operation test	Tp=75°C 240h	Panel surface
5	Low temperature operation test	Ta=0°C 240h	
6	Vibration test (non- operating)	Frequency: 10~57Hz/Vibration width (one side): 0.153mm : 57~500Hz/Gravity: 19.6 m/s ² Sweep time : 11 minutes Test period : 3 hours (1 hour for each direction of X,Y,Z)	
7	Shock test (non- operating)	Max. gravity : 490m/s ² Pulse width : 11ms, half sine wave Direction : ±X, ±Y, ±Z once for each direction.	
8	ESD test	Human model	
9	EMI	VCCI (Class B)	

[Result Evaluation Criteria]

Under the display quality test conditions with normal operation state, these shall be no change which may affect practical display function. (normal operation state : Temperature:15~35°C, Humidity:45~75%, Atmospheric pressure:86~106kpa)

15. Others

15-1 Lot No. Label:

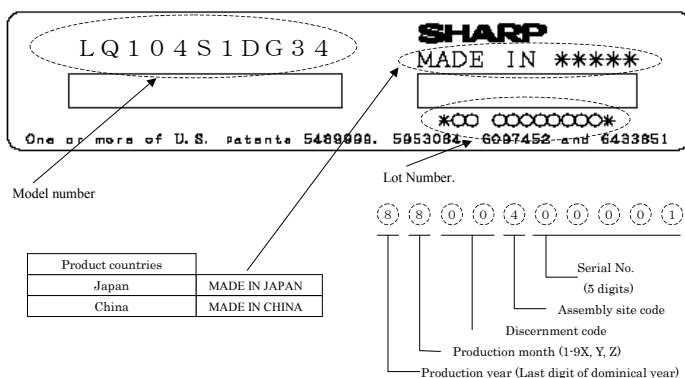

15-2 Packing box Label:

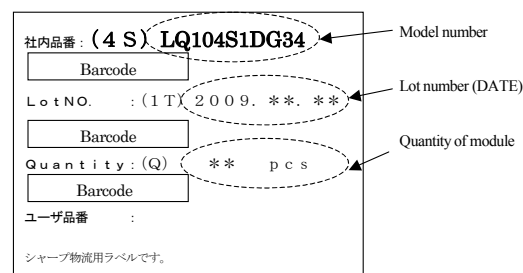

Internal Use Only
R. C.

※R.C. (RoHS Compliance) means these parts have corresponded with the RoHS directive.

15-3 If any problem occurs in relation to the description of this specification sheet, it shall be resolved through discussion with spirit of cooperation.

16. Storage conditions

<Environmental condition range of storage temperature and humidity>

Temperature 0 to 40 degrees Celsius

Relative humidity 95% and below

【Note】 Please refer below as a mean value of the environmental conditions.

Summer time temperature 20 to 35 degrees Celsius

humidity 85% and below

Winter time temperature 5 to 15 degrees Celsius

humidity 85% and below

Please maintain within 240 hours of accumulated length of storage time, with conditions of 40 degrees Celsius and room humidity of 95%.

Direct sun light

Please keep the product in a dark room or cover the product to protect from direct sun light.

Atmospheric condition

Please refrain from keeping the product with possible corrosive gas or volatile flux.

Prevention of dew

* Please store the product carton either on a wooden pallet or a stand / rack to prevent dew.

Do not place directly on the floor. In addition, to obtain moderate ventilation in between the pallet's Top and bottom surfaces, pile the cartons up in a single direction and in order.

* Please place the product cartons away from the storage wall.

* Please maintain the storage area with an appropriate ventilation. It is recommendable to furnish the storage area with equipments such as ventilation systems.

* Please maintain the ambient temperature within the range of natural environmental fluctuation.

Storage period

Within above mentioned conditions, maximum storage period should be one year.

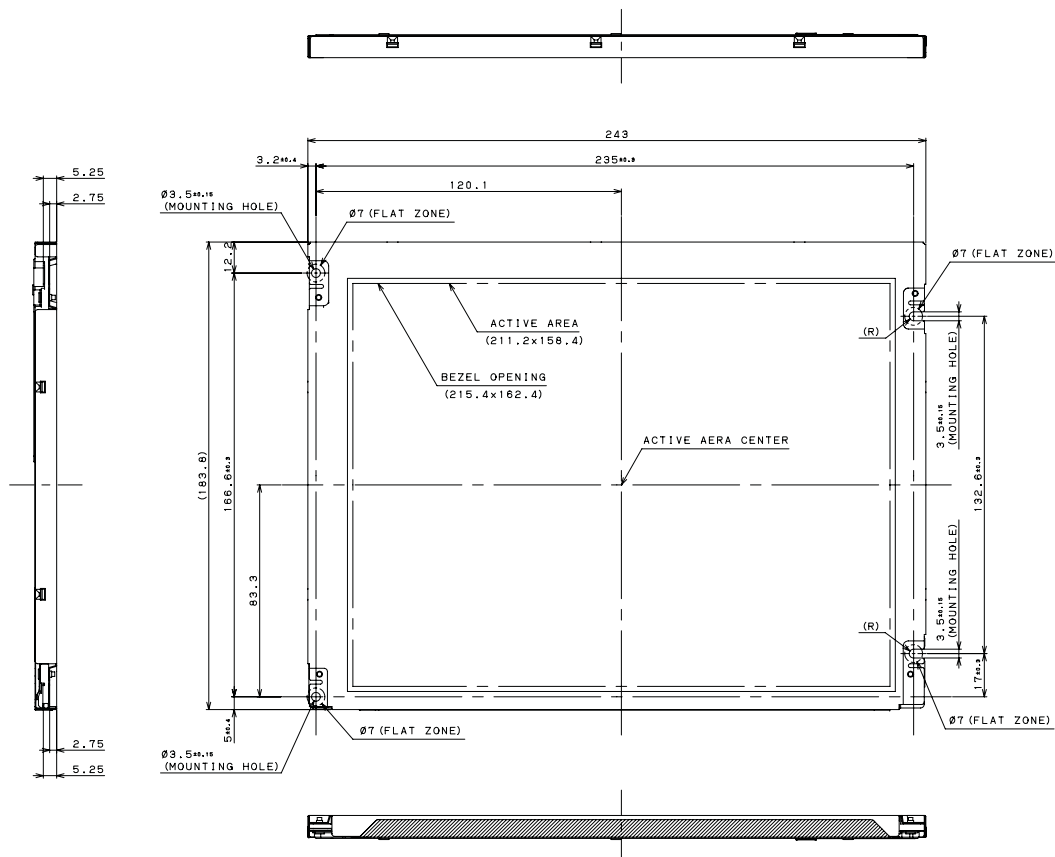

DETAIL OF CN2

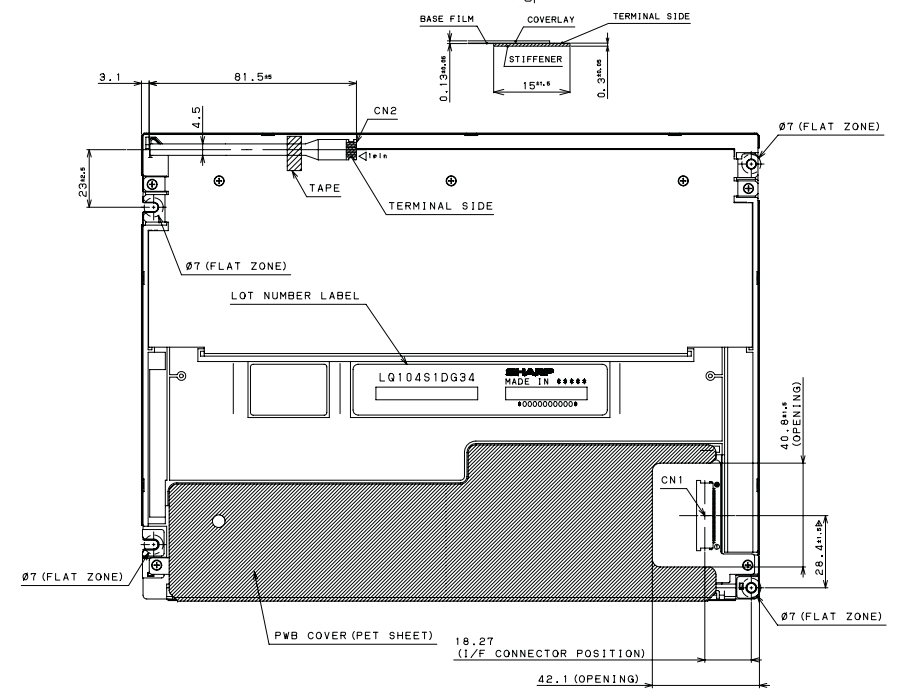
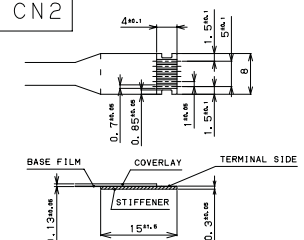

INTERFACE CONNECTOR

CN1: PIN LAYOUT (40PIN)

pin	1	2	3	4	5	6	7	8	9	10	11	12	13	14	15
	Test1 (GND)	GND	CK	GND	Test2 (GND)	Test3 (OPEN)	R0	R1	R2	GND	R3	R4	R5	GND	G0
16	17	18	19	20	21	22	23	24	25	26	27	28	29	30	31
G1	G2	GND	G3	G4	G5	GND	B0	B1	B2	GND	B3	B4	B5	GND	Test4 (OPEN)
32	33	34	35	36	37	38	39	40							
GND	Test5 (OPEN)	GND	ENAB	N. C.	VCC	VCC	N. C.	VCC							

CORRESPONDING CONNECTOR : 9686S-40B-GF (IRISO)

CN2:

1	+	(CH1)
2	-	(CH1)
3	+	(CH2)
4	-	(CH2)
5	+	(CH3)
6	-	(CH3)

CORRESPONDING CONNECTOR : 9664S-06A-GFN1 (IRISO)

BEZEL/DISPLAY POSITION

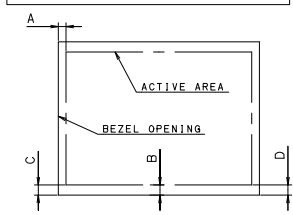

LED-FPC BENDED FORM (Reference)

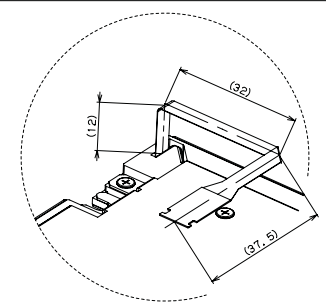

- 1) TOLERANCE X DIRECTION A: 2.1±0.8
- 2) TOLERANCE Y DIRECTION B: 2.0±0.8
- 3) OBLIQUITY OF DISPLAY AREA |C-D| < 0.8

NOTES

- 1) UNSPECIFIED TOLERANCE TO BE ±0.5.
- 2) WARPING OF COMPONENTS SUCH AS TAPE, BEZEL, PCB, CHASSIS, FPC, PROTECTION COVER, ETC. ARE EXCLUDED FROM THICKNESS AND DIMENSIONS OF THE MODULE.
- 3) RECOMMENDED TIGHTEN TORQUE FOR MOUNTING 0.294±0.02N·m (3.0±0.2kgf·cm)

Fig.1 LQ104S1DG34 OUTLINE DIMENSIONS

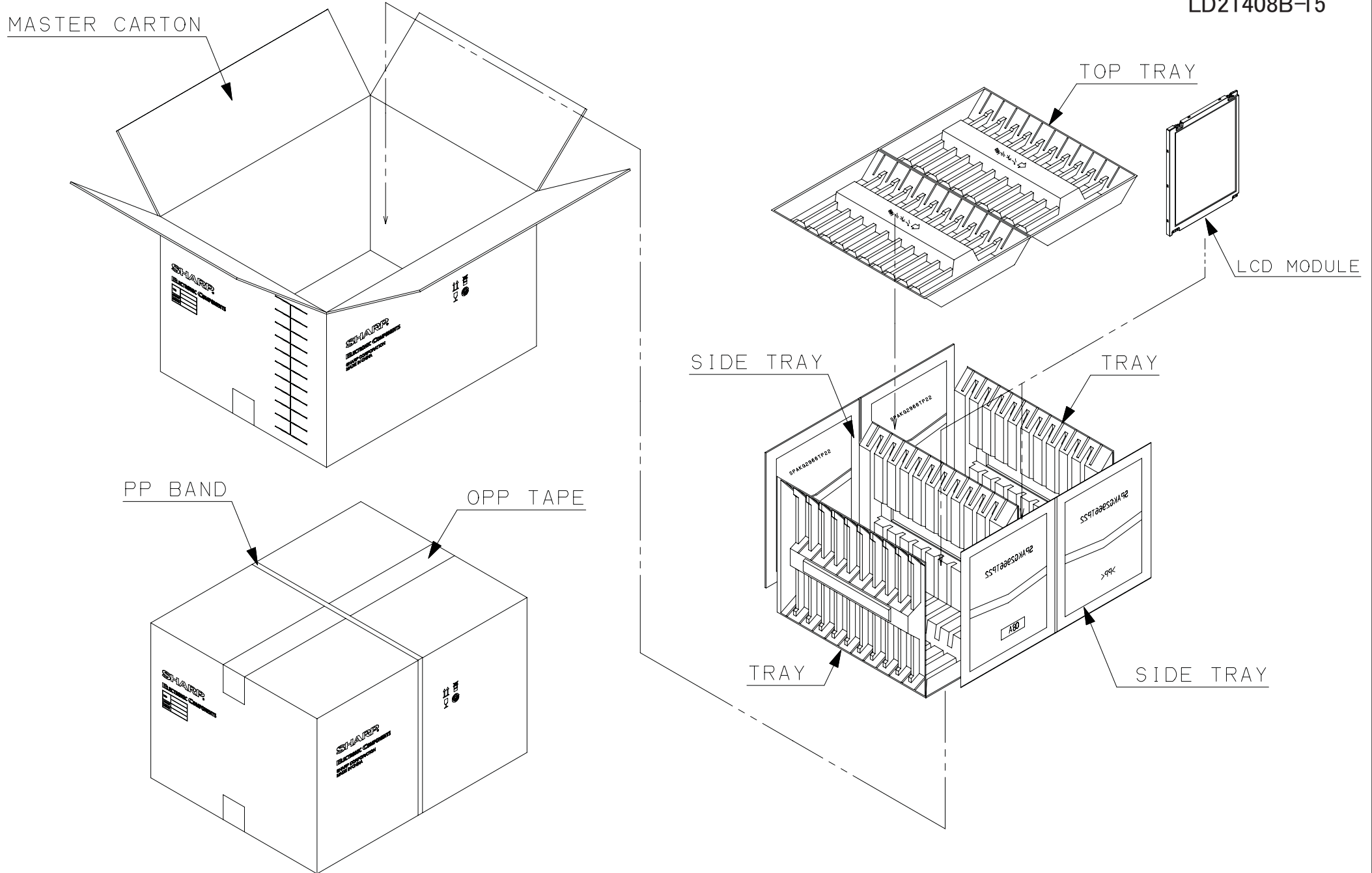

< Fig4. PACKING FORM >